



WAGNER® G10-XL AIRLESS SPRAY GUNS



PART NUMBERS AND SCHEMATICS GUIDE

Company Profile

Since 1944, Marco has developed a strong tradition of providing innovative and reliable products and services to the surface preparation and protective coatings industries. We are the world's premier provider of Abrasives, Blasting, Coating, Dust Collectors, Engineered Systems, Rental, Safety, Service, Repair, & Modernization, and Vacuums.

Through innovative designs and a total commitment to quality, Marco manufactures products that increase production rates, create a safer workplace, and reduce maintenance costs. Marco's industry experience, manufacturing capabilities, legendary customer service, product availability, logistics services, and technology leadership is your assurance that we deliver high quality products and services, providing the best value to you, our customer.

The Marco Difference

- **Industry Experience** – With Marco on your team, you have access to expertise which can only come from decades of industry leadership. We have organized our engineering department, production specialists, customer operations, and safety support into a “Center of Competence.” As a Marco customer, you have access to hundreds of years of cumulative experience related to your operations.
- **Manufacturing Excellence** – Marco is a U.S. based, ISO 9001:2008 certified manufacturer of equipment for the Surface Preparation and Protective Coatings industries. Marco's engineers benchmark the industry to ensure that we design and manufacture superior products that set the “Gold Standard” for performance, safety, and quality.
- **Legendary Customer Service** – Marco's legendary customer service team is staffed by friendly, highly-trained individuals who are focused on providing the highest level of product support, order accuracy, and customer satisfaction.
- **Product Availability** – We stock over 10,000 SKU's and have more than 45 shipping locations to serve North American and International markets for all major brands of blasting and coating equipment. As the largest provider of surface preparation and protective coatings equipment in the world, our inventory levels and product availability are unmatched.
- **Logistics Services** – Marco's in-house logistics team is dedicated to moving your shipment anywhere in the world. We move more than 14,000 truckloads every year, allowing you to save on freight costs by leveraging our buying power. Lower your process costs with a single invoice, which includes product and freight.
- **Technology Leadership** – Our website provides: Operator's Manuals, Part Numbers and Schematics Guides, SDS information, and Features & Specifications Guides, providing access to information 24/7. Our Extranet application allows you to receive quotes and place orders online. Our Intranet maintains a complete record of your purchase history to assist with ongoing support of your existing equipment and future purchasing decisions.

Vision Statement

Marco is the world's premier provider of Abrasives, Blasting, Coating, Dust Collectors, Engineered Systems, Rental, Safety, Service, Repair, & Modernization, and Vacuums.

Mission Statement

Marco provides strong leadership and innovation to the surface preparation and protective coatings industries. We dedicate our efforts to the continuous improvement of our products, services, processes, people, and most importantly, the quality of our customer's experience.

Quality Statement

Marco is committed to providing superior quality in the design, manufacturing, distribution, rental, service, and repair of our products. Our ISO 9001:2008 certification extends throughout all operations in all locations. Continuous improvement of our processes and supply chain Integration comprise the core of our business strategy for delivering exceptional quality and value in all Marco products and services.

Management Philosophy

We are a company dedicated to the success of every customer and associate. We discuss, debate, challenge, measure, and test our ideas. We will be boundless and limitless in our passion to improve. Through sound leadership and dedicated associates, we will ensure a long term, profitable future for Marco, our associates, customers, and suppliers.

TABLE OF CONTENTS



Table of Contents	3
Wagner® G10-XL Airless Spray Guns	4-9
Wagner® G10-XL Guns Part Numbers	4
TR Tips	5
Part Numbers and Schematics.....	6-7
Tip Guards	8
Gun Handle Filters.....	9
Maintenance Notes	10-11

PART NUMBERS AND SCHEMATICS GUIDE

WAGNER® G10-XL AIRLESS SPRAY GUNS					
	Part Numbers	Trigger Style	Tip	Tip Guard	Maximum Working Pressure
	20W0296236	2-Finger	517 TR1	Red	3,600 psi
	20W0286028	2-Finger	517 TR2	Red	3,600 psi
	20TS0538005	4-Finger	517 TR1	Red	3,600 psi
	20W0286029	4-Finger	517 TR2	Red	3,600 psi

PART NUMBERS AND SCHEMATICS GUIDE

TR TIP SPECIFICATIONS

Part Numbers		Tip Guard	Maximum Working Pressure	Color	Typical Applications	Typical Materials
	TR1 Tip (20TS695xxx)	No Build Guard	3600 psi	Red	Bridges, Tanks, Farms, Structural Steel, or Roofing	Virtually all Paints and Coatings – Solvent and Water-base
	TR2 Tip (20TS692xxx)	No Build Guard	3600 psi	Red	Bridges, Tanks, Farms, Structural Steel, or Roofing	Virtually all Paints and Coatings – Solvent and Water-base

TR1 Tips (20TS695xxx)

		ORIFICE SIZE (Inches)									
		IN	.009	.011	.013	.015	.017	.019	.021	.025	.027
FAN WIDTH	2-4										
	4-6	209	211	213	215	217					
	6-8		311	313	315	317					
	8-10		411	413	415	417					
	10-12			513	515	517	519	521	525		
	12-14										627
	Flow Rate (gpm)		.09	.12	.18	.24	.31	.39	.47	.67	.78

TR2 Tips (20TS692xxx)

		ORIFICE SIZE (Inches)											
		IN	.009	.011	.013	.015	.017	.019	.021	.023	.027	.031	.035
FAN WIDTH	2-4												
	4-6												
	6-8		311	313									
	8-10				415	417							
	10-12				515	517	519	521					535
	12-14									627			635
	14-16												
	16-18											831	
	18-20												
	20-22												
	22-24												
	24-26									1223		1231	
	Flow Rate (gpm)		.09	.12	.18	.24	.31	.39	.47	.57	.78	1.03	1.32

PART NUMBERS AND SCHEMATICS GUIDE

Wagner® G-10 XL Airless Spray Gun



Item #	Part #	Description
Fig. 1		
1	20W0296228	Gun Head
2	20W0296284	Trigger Screw – Short
3	20W0296285	Trigger Assembly, 4-Finger Gun <i>(Includes Item #'s: 2 and 17)</i>
4	20W0296230	Trigger Guard
5	20W0296270	Needle and Spring Assembly
6	20W0296404	Diffuser
7	20W0297045	Seal
8	20W0297007	Tip Seal
9	20W0271441	Hook Guide
10	20W661012	Guard Assembly
11	20W0271442	Latch Guide
12	20W0296641	Collar
13	20TS692517	TR2 Tip, 517 <i>(Includes Item #'s: 7-9 and 11-12)</i>
14	20W9910201	Lock Nut
15	20W0296222	Rear Housing
16	20W0296286	Retractor Pin
17	20W0296287	Trigger Screw – Long
18	20W0089958	Filter – Medium
19	20W560038	Handle Seal
20	20W0296342	Handle
21	20W0347706	Swivel
22	20W0296343	Spring
23	20W0296291	Trigger Assembly, 2-Finger Gun
24	20W0279185	Collar Assembly, 2-Finger Gun
—	20W0271065	Collar Kit <i>(Includes Item #'s: 9 and 11-12)</i>
—	20W0296345	Handle Assembly <i>(Includes Item #'s: 20–22)</i>
—	20W0296294	Gun Repair Kit <i>(Includes Item #'s: 5, 6, and 14)</i>
—	206M508	Part Numbers and Schematics Guide – Wagner® G10-XL Airless Spray Guns
—	209V508	Operators Manual – Wagner® G10-XL Airless Spray Guns

PART NUMBERS AND SCHEMATICS GUIDE

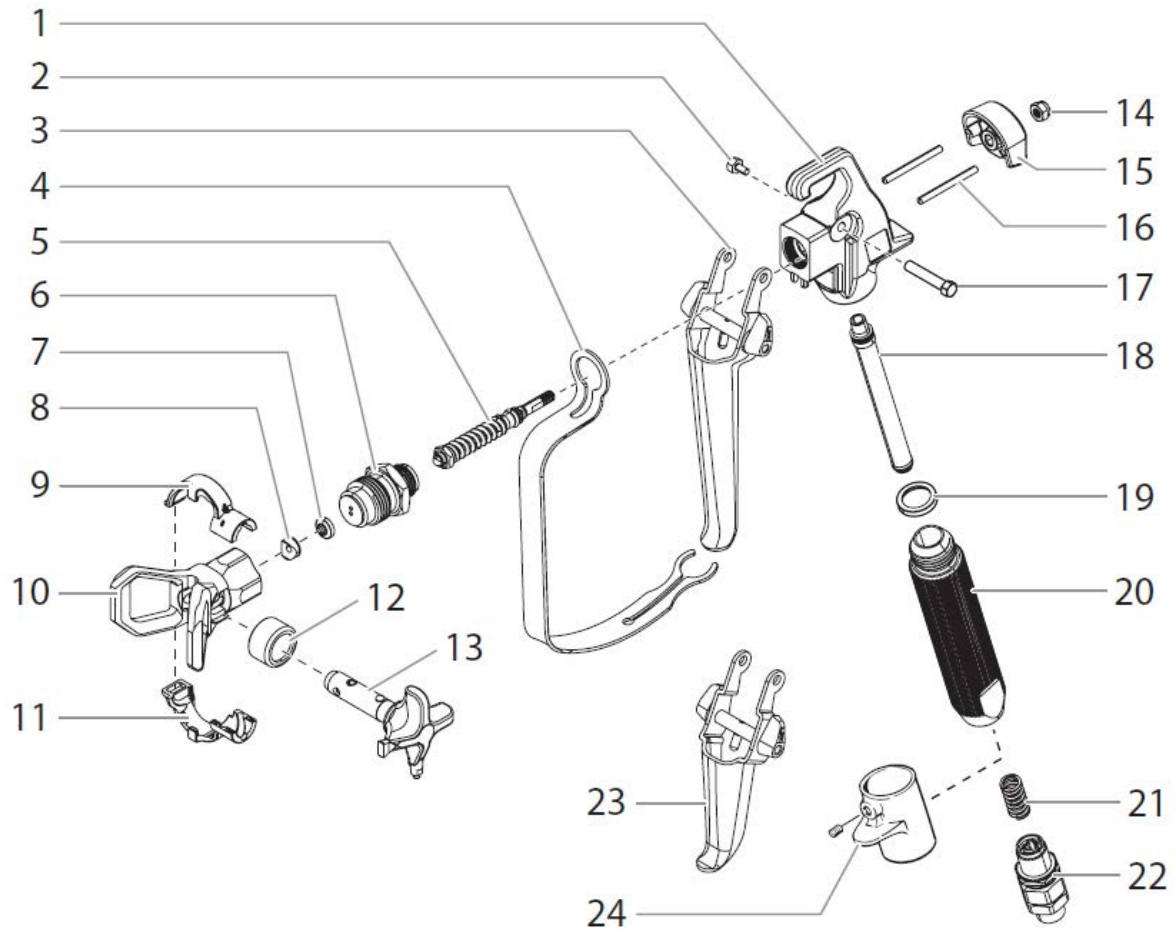



Figure 1: Wagner® G-10 XL Airless Spray Gun



PART NUMBERS AND SCHEMATICS GUIDE

		TIP GUARD SUMMARY			
Part Numbers		Color	Tip Style	Thread Size	For Use With:
	20W0289228	Black	TR1, TR2	7/8 Inch	Wagner® G10-XL
	20W450100A	Black	TR1, TR2	7/8 Inch	Adjustable

PART NUMBERS AND SCHEMATICS GUIDE

		GUN HANDLE FILTERS			
Part Numbers		Type	Color	Application	Packaging
	20W0089960B	Extra Fine 180 Mesh	Red	Synthetic resin, enamels, clean varnishes, stains, azures	2/Package
	20W0034383B	Extra Fine 180 Mesh	Red	Synthetic resin, enamels, clean varnishes, stains, azures	One Each
	20W0089959B	Fine 100 Mesh	Yellow	Base coat enamels, primer enamels, fillers, marking paints, textured enamels	2/Package
	20W0089324B	Fine 100 Mesh	Yellow	Base coat enamels, primer enamels, fillers, marking paints, textured enamels	One Each
	20W0089958B	Medium	White	Emulsions, latex paints, acrylic paints	2/Package
	20W0034377B	Medium	White	Emulsions, latex paints, acrylic paints	One Each
	20W0089957B	Coarse	Green	Filler paints, large area surfaces	2/Package
	20W0089323B	Coarse	Green	Filler paints, large area surfaces	One Each

GLOBAL HEADQUARTERS

- 3425 East Locust Street
Davenport, IA 52803

ph: 800.BLAST.IT (800.252.7848)
ph: 563.324.2519
fax: 563.324.6258

REGIONAL BRANCH OFFICES

- **Iowa**
Davenport
- **Louisiana**
Gonzales
Harvey
Lafayette
- **Ohio**
Youngstown
- **Texas**
Beaumont
Corpus Christi
Deer Park

40+ NATIONWIDE SHIPPING LOCATIONS



★ Marco Regional Branch Offices and Shipping Locations ● Direct Shipping Locations



ABRASIVES
BLASTING
COATING
DUST COLLECTORS
ENGINEERED SYSTEMS
RENTAL
SAFETY
SERVICE, REPAIR, & MODERNIZATION
VACUUMS

CONTACT MARCO

800.BLAST.IT
(800.252.7848)
563.324.2519
FAX: 563.324.6258

WWW.MARCO.US
SALES@MARCO.US