



# VACMASTER® 15T TIER 4 DIESEL ABRASIVE VACUUMS



**BUILT MARCO**  
**TOUGH**  
MARCO MANUFACTURED

**PART NUMBERS AND SCHEMATICS GUIDE**

## Company Profile

Since 1944, Marco has developed a strong tradition of providing innovative and reliable products and services to the surface preparation and protective coatings industries. We are the world's premier provider of Abrasives, Blasting, Coating, Dust Collectors, Engineered Systems, Rental, Safety, Service, Repair, & Modernization, and Vacuums.

Through innovative designs and a total commitment to quality, Marco manufactures products that increase production rates, create a safer workplace, and reduce maintenance costs. Marco's industry experience, manufacturing capabilities, legendary customer service, product availability, logistics services, and technology leadership is your assurance that we deliver high quality products and services, providing the best value to you, our customer.

## The Marco Difference

- **Industry Experience** – With Marco on your team, you have access to expertise which can only come from decades of industry leadership. We have organized our engineering department, production specialists, customer operations, and safety support into a “Center of Competence.” As a Marco customer, you have access to hundreds of years of cumulative experience related to your operations.
- **Manufacturing Excellence** – Marco is a U.S. based, ISO 9001:2008 certified manufacturer of equipment for the Surface Preparation and Protective Coatings industries. Marco's engineers benchmark the industry to ensure that we design and manufacture superior products that set the “Gold Standard” for performance, safety, and quality.
- **Legendary Customer Service** – Marco's legendary customer service team is staffed by friendly, highly-trained individuals who are focused on providing the highest level of product support, order accuracy, and customer satisfaction.
- **Product Availability** – We stock over 10,000 SKU's and have more than 45 shipping locations to serve North American and International markets for all major brands of blasting and coating equipment. As the largest provider of surface preparation and protective coatings equipment in the world, our inventory levels and product availability are unmatched.
- **Logistics Services** – Marco's in-house logistics team is dedicated to moving your shipment anywhere in the world. We move more than 14,000 truckloads every year, allowing you to save on freight costs by leveraging our buying power. Lower your process costs with a single invoice, which includes product and freight.
- **Technology Leadership** – Our website provides: Operator's Manuals, Part Numbers and Schematics Guides, SDS information, and Features & Specifications Guides, providing access to information 24/7. Our Extranet application allows you to receive quotes and place orders online. Our Intranet maintains a complete record of your purchase history to assist with ongoing support of your existing equipment and future purchasing decisions.

## Vision Statement

Marco is the world's premier provider of Abrasives, Blasting, Coating, Dust Collectors, Engineered Systems, Rental, Safety, Service, Repair, & Modernization, and Vacuums.

## Mission Statement

Marco provides strong leadership and innovation to the surface preparation and protective coatings industries. We dedicate our efforts to the continuous improvement of our products, services, processes, people, and most importantly, the quality of our customer's experience.

## Quality Statement

Marco is committed to providing superior quality in the design, manufacturing, distribution, rental, service, and repair of our products. Our ISO 9001:2008 certification extends throughout all operations in all locations. Continuous improvement of our processes and supply chain Integration comprise the core of our business strategy for delivering exceptional quality and value in all Marco products and services.

## Management Philosophy

We are a company dedicated to the success of every customer and associate. We discuss, debate, challenge, measure, and test our ideas. We will be boundless and limitless in our passion to improve. Through sound leadership and dedicated associates, we will ensure a long term, profitable future for Marco, our associates, customers, and suppliers.

# TABLE OF CONTENTS

<b>Company Profile</b> .....	1
<b>Table of Contents</b> .....	2
<b>Part Numbers</b> .....	3
<b>Specifications</b> .....	4
<b>Assembly Part Numbers and Schematics</b> .....	5
Front Assembly .....	5
Rear Assembly .....	7
Right Side Front Assembly .....	9
Center Assembly .....	11
Right Side Rear Assembly .....	13
Left Side Front Assembly .....	15
Left Side Rear Assembly .....	17
Double Lock Valve Assembly .....	19
Fuel Tank .....	20
Fan Belt Assembly .....	21
Intake Filter Housing .....	22
Vacuum Light Bar .....	23
Pneumatic Piston Vibrators .....	24
Pulser System Assembly .....	25
Filter Bag Pulsers .....	27
Emergency-Stop Station .....	28
Compressor Assembly .....	29
Vacuum Hose Support Bracket .....	32
Trailer .....	33
Wear Plates and Baffles .....	35
Hydraulic Hoses .....	37
<b>Hazard Identification Decals</b> .....	38
<b>Optional Accessories</b> .....	43
<b>Literature References</b> .....	45

## PART NUMBERS

### VACMASTER® 15T TIER 4 DIESEL ABRASIVE VACUUMS

	Engine Type	Filter Cartridge Style	
<b>Part Numbers</b>	<b>Tier 4</b>	<b>Acrylic-Coated Filter Bags</b>	<b>Filter Bags Quantity</b>
10106515	X	X	37



# SPECIFICATIONS

<b>Performance:</b>	MAX 2367 CFM
<b>Filter Cartridge Style:</b>	Acrylic-Coated Filter Bags 37 Required
<b>Filter Cleaning:</b>	Pulse System, 25–30 second intervals. Pulse Duration: 200–350 millisecond
<b>Vacuum</b>	27" Hg
<b>Ducting Connections:</b>	6" I.D. Inlet with 4" adapter
<b>Inspection Ports:</b>	One 10" Viewable to Filters with access ports to hopper
<b>Material Removal:</b>	Automatic Direct Dump
<b>Blower:</b>	Rotary lobe, positive displacement with jet inlet
<b>Engine:</b>	Diesel, Tier 4 Final, 174 Horsepower
<b>Fuel Capacity:</b>	Capacity: 116 Gallons    Type: Diesel
<b>Air Compressor:</b>	On Board 13 CFM
<b>Electrical System:</b>	12-Volt DC
<b>Engine Protection:</b>	Engine Monitoring System with automatic shutdown
<b>Fluid Specifications:</b>	Hydraulic Oil: H46 or equivalent, 2 gallon capacity Diesel Fuel: See Engine Operator's Manual for type Grease/Lubricator: Shell Alvania Grease EP or equivalent Alcohol Evaporator: Alcohol 99 Isopropyl, 32 oz. capacity Vibrator Lubricator: 4 oz. pneumatic air tool oil DEF: BlueDEF Diesel Exhaust Fluid Blower Oil: ROOTS™ synthetic lubricating oil
<b>Unit Dimensions:</b>	Weight:                    11,250 pounds (empty) Length:                    19' 7" Width:                     7' 10" Height:                    11' 6" Raised Height:           19' Dump Clearance:        8'

# ASSEMBLY PART NUMBERS AND SCHEMATICS

## Front Assembly

Item #	Part #	Description
<b>Fig. 1</b>		
1	10106485	Perkins Engine 174 Hp Tier 4
2	10104455	Trailer (See Figure 20)
3	10103986	Clutch
4	1015552	Female Twist Lock Plug Two Prong
5	10104071	E-Stop Control Station
6	10104821	Wema Analog Fuel Level Gauge
7	1015551	Male Twist Lock Plug Two Prong
8	10104703	Cord Grip Nylon 1/2"-NPT .2-.47 Diameter
9	10104063	Legend Plate - Emergency Stop
10	1015540	16/2 Xtreme Duty Power Cord - Red
11	10104820	Panel Mount Pressure Gauge 0-160 PSI
12	10104001	Shifting Lever
—	10103959	Oil Filter
—	10106701	Primary Fuel Filter
—	10107271	Secondary Fuel Filter
—	10107272	Outer Air Filter
—	10107273	Inner Air Filter

# PART NUMBERS AND SCHEMATICS

Figure 1: Front Assembly

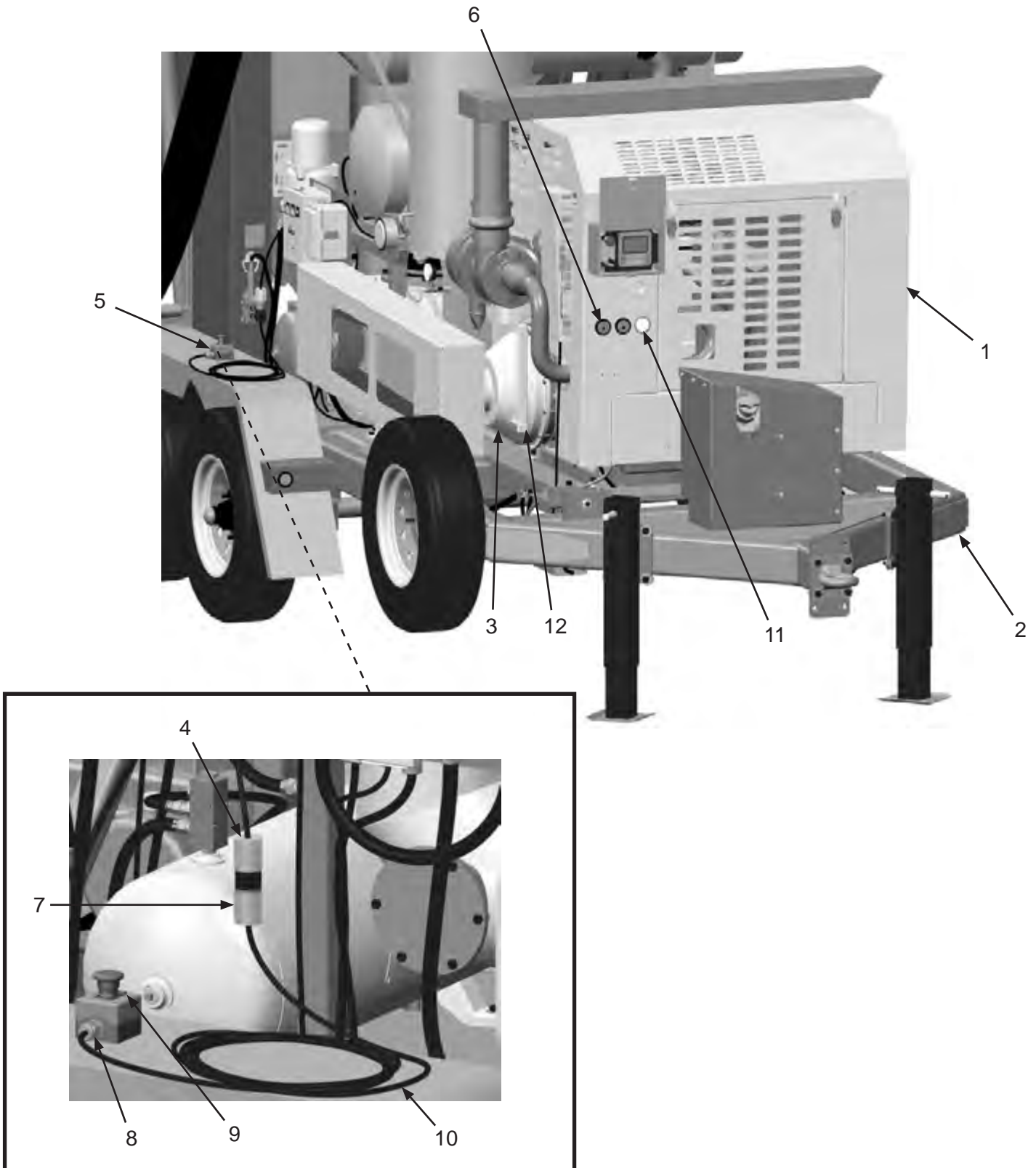

# PART NUMBERS AND SCHEMATICS

## Rear Assembly

Item #	Part #	Description	Item #	Part #	Description
<b>Fig. 2</b>			27	1012323	1/4-20 Zinc Lock Nut with Nylon Insert ( <i>Two Required</i> )
1	10104673	0-50" Differential Pressure Gauge	28	10104670	Solenoid
2	10101938	3/8-16 Hex Nut GALV. ( <i>12 Required</i> )	29	1019024	Breather Vent
3	10104665	APV Series Piston Vibrator	30	10104676	Series MPR Mini Pressure Relief
4	10104506	Dump Door	31	10L803035	1/2" Close Nipple
5	10104411	Vacuum Hopper Cone	32	1019025	1/2" Straight Conduit Body
6	10106511	Vacuum Wear Door	33	10104703	Cord Grip, 1/2" Nylon .2-.47 Diameter
7	10104638	Bulldog Trailer Jack	34	10104678	1/8" Pressure Gauge 100 PSI
8	10104439	Hatch	35	1080050	1/4" Ball Valve
9	10105334	Vacuum Light Bar	36	20PFHA60SG0406	1/4" (F) x 3/8" (F) Swivel Union ( <i>Two Required</i> )
10	10104498	Vacuum Header	37	20PFHA24SA0404	1/4" Hex Nipple ( <i>Three Required</i> )
11	10104459	Blower Exhaust Silencer	38	1014239	1/8" x 1/8" 90° Fitting
12	10104461	Blower Intake Silencer	39	1011210	1/4" NPT x 1 1/2" Nipple
13	20PFHA60UA0406	1/4" (M) x 3/8" (F) 90° Swivel ( <i>Two Required</i> )	40	20PFHA60SA0806	1/2" (M) x 3/8" (F) Swivel Union
14	10104667	2.5" Pneumatic Cylinder	41	1011819	1/2" Street Elbow
15	10104668	Piston Rod Clevis	42	20100571	1/2" NPT 3-Way Brass Ball Valve
16	10104507	Dump Arm	43	1011818	1/2" x 1/4" Galvanized Bushing
17	10104234	3/8-16 x 1-1/4" Hex Bolt Zinc ( <i>Four Required</i> )	44	10104486	Vacuum Lid Overcenter Clamp ( <i>12 Required</i> )
18	10101942	3/8" Flat Washer - Galvanized ( <i>20 Required</i> )	45	10104479	Lid Weldment
19	10101936	3/8" Lock Washer - Zinc ( <i>16 Required</i> )	46	10104705	3/8-16 x 1" Bolt Zinc ( <i>12 Required</i> )
20	1012318	3/8-16 Hex Nut ( <i>Four Required</i> )	47	10105189	Wear Door Liner
21	10104512	Dump Door Gasket	48	10105190	Wear Door
—	10104511	Dump Door Internal Plate	49	10104679	3/8" (M) Swivel Recoil AH 225 PSI
22	20100160	1/2-13 x 4-1/2" Zinc Hex Bolt	50	10104637	6" Bandlock Clamp
23	10100674	1/2" Flat Washer ( <i>Two Required</i> )	51	10104636	6" 90° Elbow
24	20100124	1/2-13 Hex Lock Nut - Zinc	52	10104502	Dump Section Gasket
25	20PFHA25UA0404	1/4" Male 90° Elbow	53	10104503	Vacuum Discharge Tube
26	1019044	1/4-20 x 1-3/4" Zinc Bolt ( <i>Two Required</i> )	54	10104426	Vacuum Hopper Section Gasket
			—	10106513	6" Gasket



# PART NUMBERS AND SCHEMATICS

Figure 2:

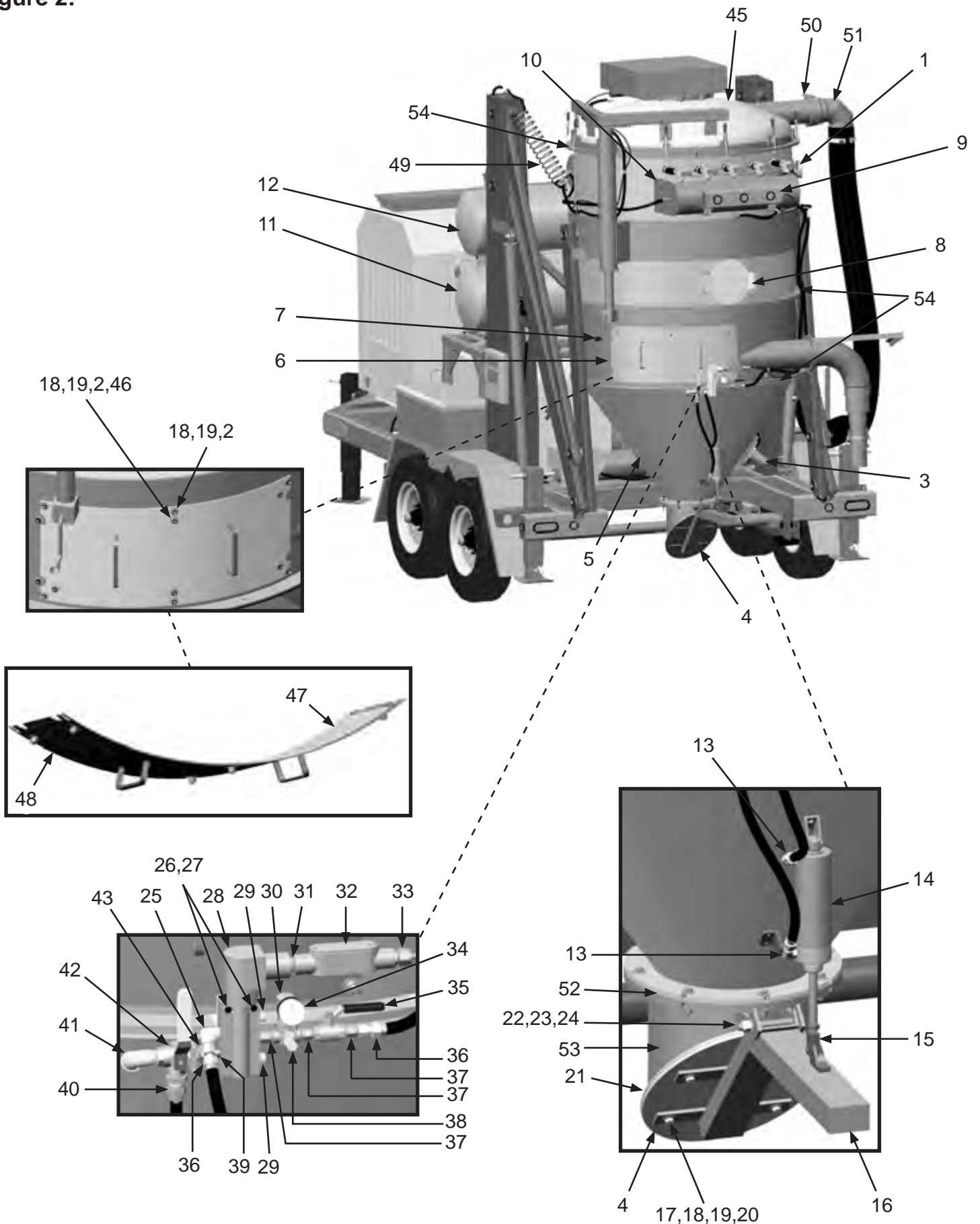

# PART NUMBERS AND SCHEMATICS

## Right Side Front Assembly

Item #	Part #	Description
<b>Fig. 3</b>		
1	—	Pulse Timer Control Box
2	10104559	Vacuum Butterfly Cover
3	10104493	Vacuum Aux Header
4	10104456	Blower Top Shaft Left Discharge
5	10104071	E-Stop Control Station
6	10104579	Vacuum Belt Guard Cover
7	10104673	0—50" Differential Pressure
8	10104614	10" x 8" x 4" Nema 4 Enclosure
9	10104615	8" x 4" x 5" Fiberglass Latch Enclosure
10	10104610	Horizontal Pressure Tank - 15 Gallon
11	10104674	Lubricator 1/2" NPT 156 CFM
12	10VH620B	6" I.D. Vacuum Hose 20' Section
13	20RCG5050	1/2" NPT x .5—.625 Diameter Cord Grip
14	20100125	1/4-20 x 3/4" Zinc Hex Bolt <i>(Eight Required)</i>
15	10104703	1/2" NPT x .2—.47 Diameter Nylon Cord Grip <i>(Three Required)</i>
16	20RST9050	90° Liquid Tite Connection Fitting
17	10104692	12-Volt Pilot Light - Red
18	20RST50	Straight Liquid Tite Connection Fitting <i>(Two Required)</i>
19	10104686	10 Amp Circuit Breaker
20	10103305	Selector Switch - 2-Way <i>(Three Required)</i>
21	10106818	Vacuum Control Timer
22	10104109	6 Amp 50-Volt Rectifier
23	10105193	Enclosure Panel
24	20PFHA25VJ02	1/8" Female Tee <i>(Two Required)</i>
25	10104672	Differential Pressure Switch
26	20100579	1/4" O.D. Tube x 1/8" NPT PTC Swivel <i>(Four Required)</i>
27	20PFBA31095614	1/4" Tube x 1/4" NPT 90° Fitting <i>(Two Required)</i>
28	10104677	Liquid Filled Vacuum Gauge
29	1011844	1/4" Pipe Tee - Galvanized
30	10104073	Panel Lock Nut - 1/2"
31	10101940	1/4" Flat Washer - Galvanized <i>(Four Required)</i>
32	10101939	1/4-20 Stainless Steel Lock Nut with Nylon Insert <i>(Four Required)</i>
33	20PFHA60UA0606	3/8" (M) x 3/8" (F) 90° Swivel Union <i>(Four Required)</i>
34	10103631	3/8" Barb x 3/8" NPTF Brass <i>(Seven Required)</i>
35	1011809	3/8" NPT Tee <i>(Two Required)</i>
36	1011209	3/8 NPT Close Nipple
37	1011747	3/8-16 x 1" Bolt - Zinc <i>(Four Required)</i>
38	10101942	3/8" Flat Washer - Galvanized <i>(Four Required)</i>
39	10101936	3/8" Lock Washer - Zinc <i>(Four Required)</i>
40	10101938	3/8-16 Hex Nut - Galvanized <i>(Four Required)</i>
41	20PFHA60SA0606	Union Swivel 3/8" (M) x 3/8" (F) <i>(Two Required)</i>
42	10108373	1/8" NPT Inline Air Filter

# PART NUMBERS AND SCHEMATICS

Figure 3: Right Side Front Assembly

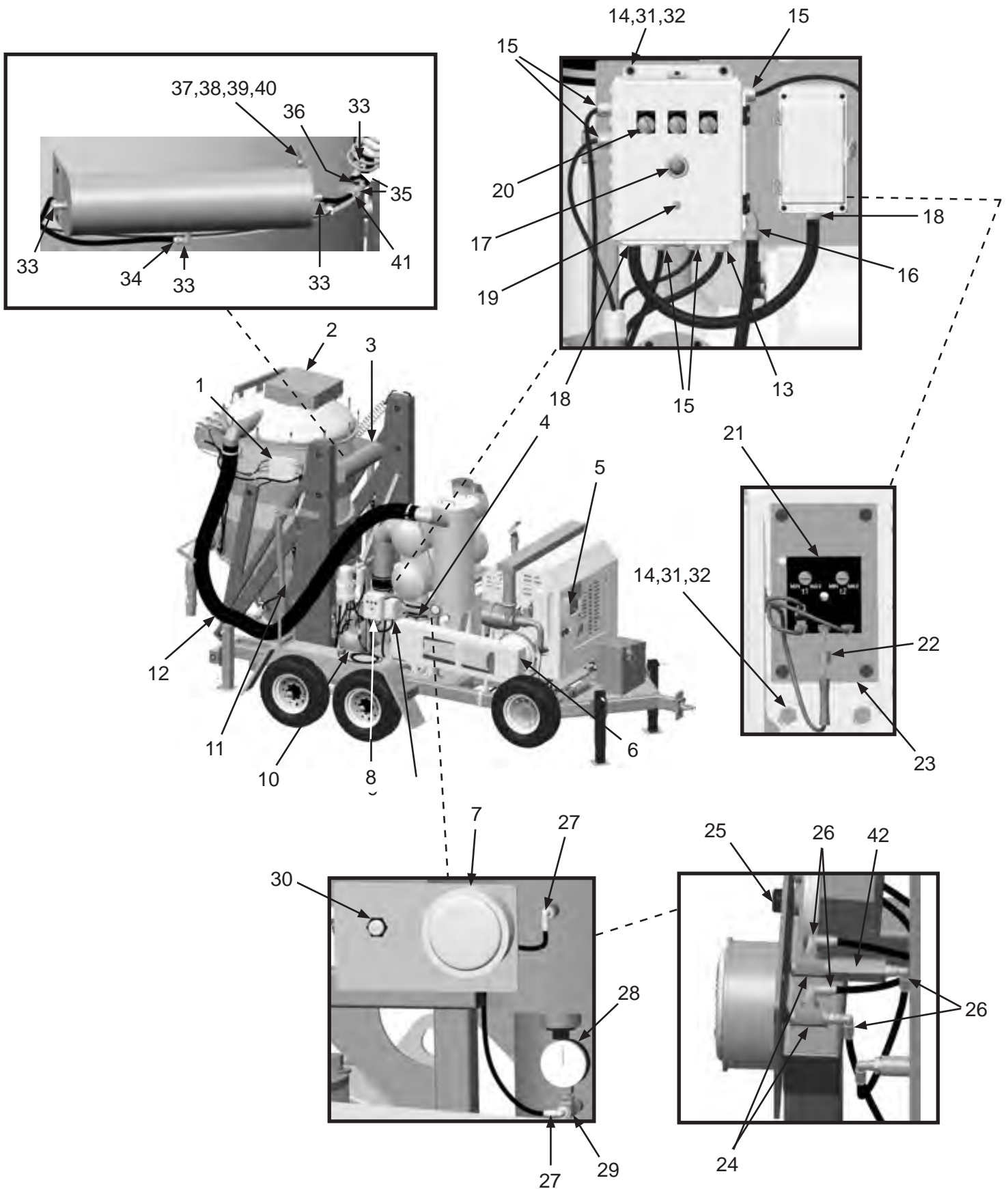

## PART NUMBERS AND SCHEMATICS

### Center Assembly

Item #	Part #	Description	Item #	Part #	Description
<b>Fig. 4</b>			27	1011217	1/4" x 2" Nipple
1	10104703	Nylon Cord Grip <i>(Two Required)</i>	28	1011832	1/4" 90° Elbow
2	20000031	8-32 x 1-1/2" Machine Screw <i>(Two Required)</i>	29	10SME025	1/4" NPT x 1/4" (F) Straight Swivel
3	10105897	Terminal Box	30	20PFHA60SA0606	3/8" (M) x 3/8" (F) Swivel Union
4	10101943	1/2-13 x 1-3/4" Hex Bolt <i>(Eight Required)</i>	31	20100195	3/8-16 x 1" Bolt <i>(12 Required)</i>
5	10100674	1/2" Flat Washer <i>(16 Required)</i>	32	20PFHA24SB0806	1/2" x 3/8" Reducing Bushing <i>(Three Required)</i>
6	10100675	1/2" Lock Washer <i>(Eight Required)</i>	33	10104611	Air Dryer
7	10101941	1/2-13 Hex Nut <i>(Eight Required)</i>	34	1012326	1/4" (M) x 1/4" (F) 90° Swivel Union
8	10104774	10-3/4" I.D. Hose <i>(Two Required)</i>	35	20PFHA60SA0806	1/2" (M) x 3/8" (F) Swivel Union
9	10103416	Banding Clamp <i>(Four Required)</i>	36	10104612	Alcohol Evaporator
10	10104715	7/8-9 x 2" Grade 5 Bolt	37	10105838	1/2" x 168" Stainless Steel Braided Hose Assembly with 1/2" (M) NPT Ends
11	10104716	7/8" Flat Washer - Zinc	38	10104684	3/8" x 2' Braided Hose
12	10104717	7/8" Lock Washer - Zinc	39	10104683	3/8" x 4-1/2' Braided Hose
13	20100195	3/8-16 x 1" Bolt <i>(Two Required)</i>	40	20PFHA60UA0808	1/2" (M) x 1/2" (F) 90° Swivel Union
14	10103400	3/8-16 x 3/4" Bolt <i>(Four Required)</i>	41	10105779	Hydraulic Power Unit
15	1035045	5/16-18 x 1" Bolt <i>(Six Required)</i>	42	10105782	SAE 6 x JIC 8 Elbow <i>(Two Required)</i>
16	10103235	Cover	43	10104714	3/4-10 x 1-5/8" Bolt <i>(Eight Required)</i>
17	10104610	Compressed Air Tank	44	10100596	3/4" Lock Washer <i>(Eight Required)</i>
18	20PFHA60UA0606	3/8" (M) x 3/8" (F) 90° Swivel Union <i>(Three Req)</i>	45	10100704	3/4" Flat Washer <i>(Eight Required)</i>
19	10104618	Pressure Manifold	46	10107990	Blower Intake Silencer Adapter
20	20PFHA60SA0604	3/8" (M) x 1/4" (F) Swivel Union <i>(Two Required)</i>	47	10107985	Silencer Exhaust Elbow
21	1028617	3/8-16 x 1-3/4" Shoulder Bolt <i>(Four Required)</i>	—	10106896	Blower Oil 100 <i>For below 0° F</i>
22	10101942	3/8" Flat Washer <i>(48 Required)</i>	—	10106897	Blower Oil 150 <i>For 0 – 32° F</i>
23	10101936	3/8" Lock Washer - Zinc <i>(15 Required)</i>	—	10105254	Blower Oil 220 <i>For 32 – 90° F</i>
24	1012318	3/8-16 Hex nut <i>(15 Required)</i>	—	10106898	Blower Oil 320 <i>For above 90° F</i>
25	10104681	1/2" NPT Pressure Relief Valve	—	10105292	Alcohol 99 Isopropyl
26	10DSHP75	3/4" Square Head Pipe Plug <i>(Two Required)</i>	—	10106512	Desiccant Element Kit

# PART NUMBERS AND SCHEMATICS

Figure 4: Center Assembly

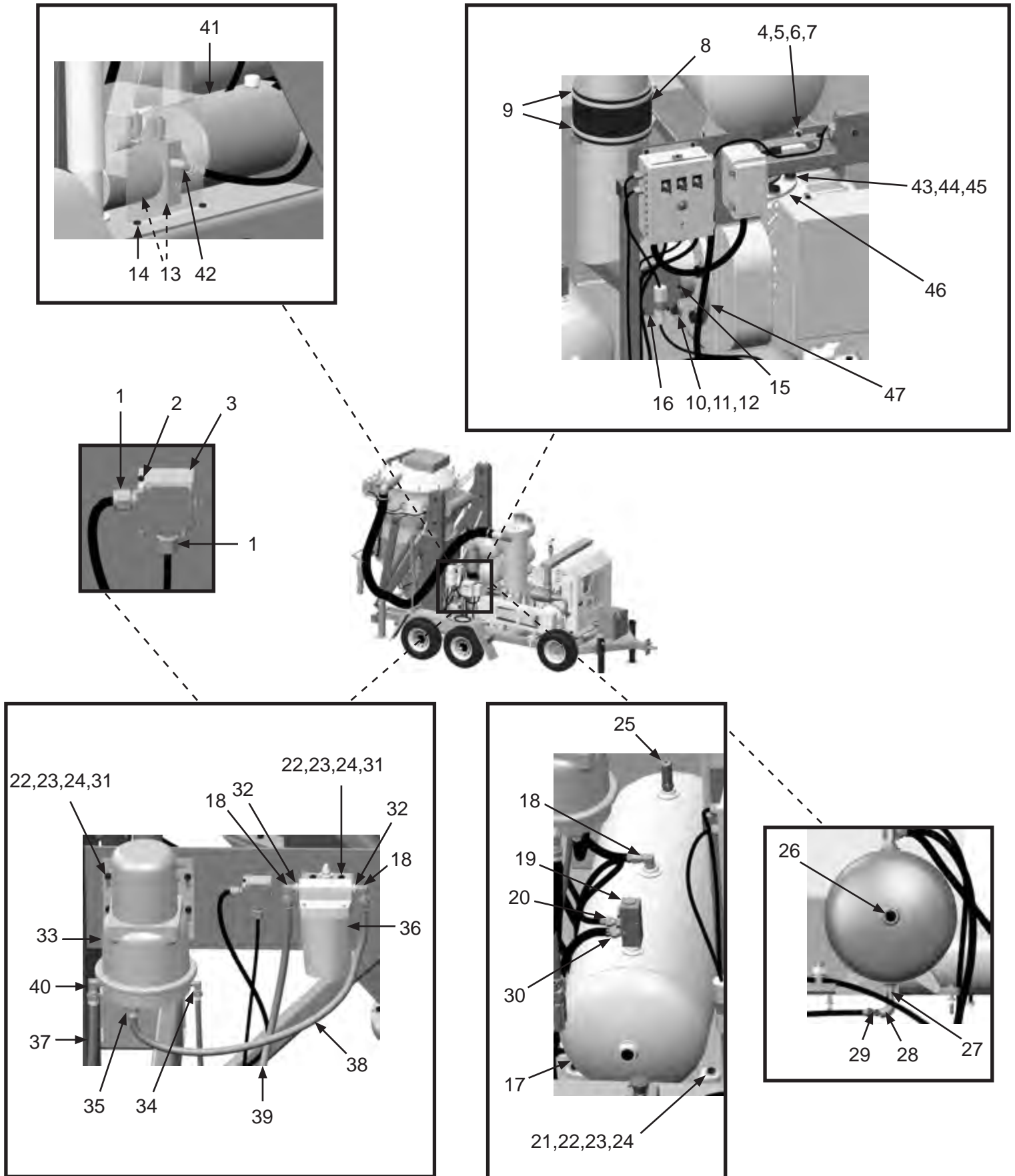

## PART NUMBERS AND SCHEMATICS

### Right Side Rear Assembly

Item #	Part #	Description	Item #	Part #	Description
<b>Fig. 5</b>			26	1080060	3/8" NPT Full Port Brass Ball Valve <i>(Two Required)</i>
1	10104559	Vacuum Butterfly Cover	27	10103624	1" Rubber Cushioned Loop Clamp
2	10101942	3/8" Flat Washer - Galvanized <i>(Five Required)</i>	28	1028617	3/8-16 x 1-3/4" Shoulder Bolt
3	10103400	3/8-16 x 3/4" Bolt <i>(Four Required)</i>	29	10101936	3/8" Lock Washer - Zinc <i>(Five Required)</i>
4	10104554	Butterfly Cover Mount Weldment	30	1012318	3/8-16 Hex Nut
5	10104537	12" Butterfly	31	10104597	Airline Drain
6	10107175	6.5" Extension Spring	32	20RCG5050	1/2" NPT x .5—.625 Diameter Cord Grip <i>(Two Required)</i>
7	10104668	Piston Rod Clevis	33	10104671	Vibrator Solenoid
8	10104538	Vacuum Butterfly Cylinder Weldment	34	20PFHA60UA0406	1/4" (M) x 3/8" (F) 90° Swivel <i>(Two Required)</i>
9	10104543	Butterfly Actuating Arm	35	10104703	1/2" NPT x .2—.47 Diameter Nylon Cord Grip <i>(Three Required)</i>
10	20100125	1/4-20 x 3/4" Zinc Hex Bolt	36	10101939	1/4-20 Stainless Steel Lock Nut with Nylon Insert <i>(Four Required)</i>
11	10104667	2.5" Pneumatic Cylinder	37	10101940	1/4" Flat Washer - Galvanized <i>(Four Required)</i>
12	1011824	1/4" Street Elbow	38	20100125	1/4-20 x 3/4" Zinc Hex Bolt <i>(Four Required)</i>
13	1011217	1/4" x 2" Nipple - Galvanized	39	10101942	3/8" Flat Washer - Galvanized <i>(Eight Required)</i>
14	10104669	Solenoid For Butterfly	40	10101938	3/8-16 Hex Nut Galvanized <i>(Four Required)</i>
15	20PFHA60UA0406	1/4" (M) x 3/8" (F) 90° Swivel	41	1011747	3/8-16 x 1" Bolt - Zinc <i>(13 Required)</i>
16	10105287	Din Connector	42	10104546	Vacuum Inlet Elbow
17	10104706	3/8-16 x 2-1/2" Thread Stud	43	10104496	Vacuum Inlet Insert
18	10100674	1/2" Flat Washer <i>(Eight Required)</i>	44	10104550	Vacuum Inlet Adapter
19	20100124	1/2-13 Hex Lock Nut <i>(Eight Required)</i>	45	10107797	4" Quick Disconnect Coupling Assembly
20	20PFHA60UA0606	3/8" (M) x 3/8" (F) 90° Swivel Union	46	10107176	6.5" Long Extension Spring - Zinc
21	20PFHA60SA0606	Union Swivel 3/8" (M) x 3/8" (F) <i>(Three Required)</i>	47	10107204	Remote Control Pendant
22	1011209	3/8" NPT Close Nipple			
23	20PFHA25UG0606	3/8" Street Elbow			
24	20PFHA24SB0806	1/2" x 3/8" Reducing Bushing <i>(Two Required)</i>			
25	10104674	Lubricator, 1/2" NPT 156 CFM			

# PART NUMBERS AND SCHEMATICS

Figure 5: Right Side Rear Assembly

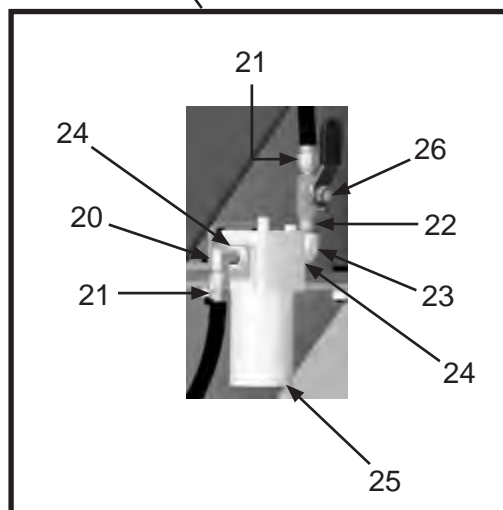
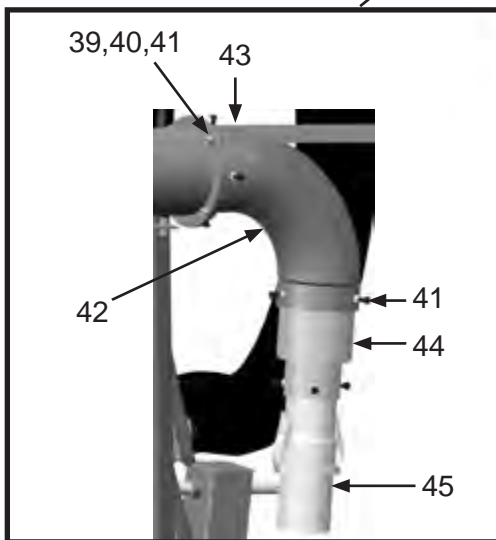
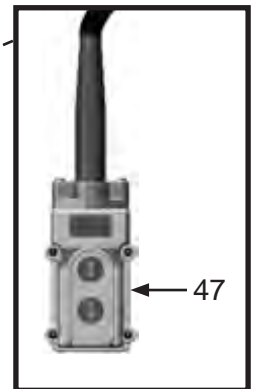
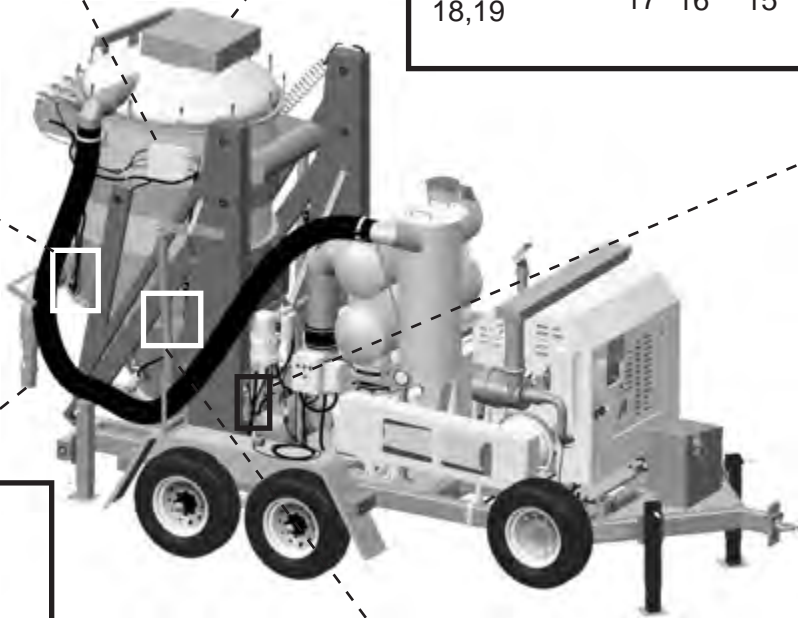
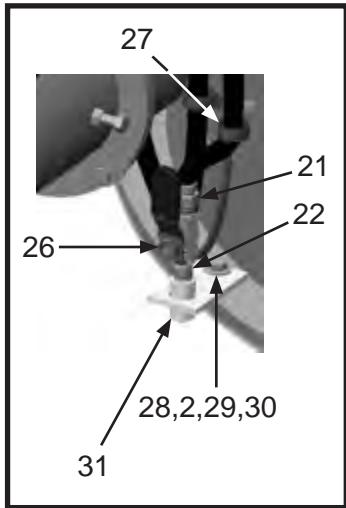
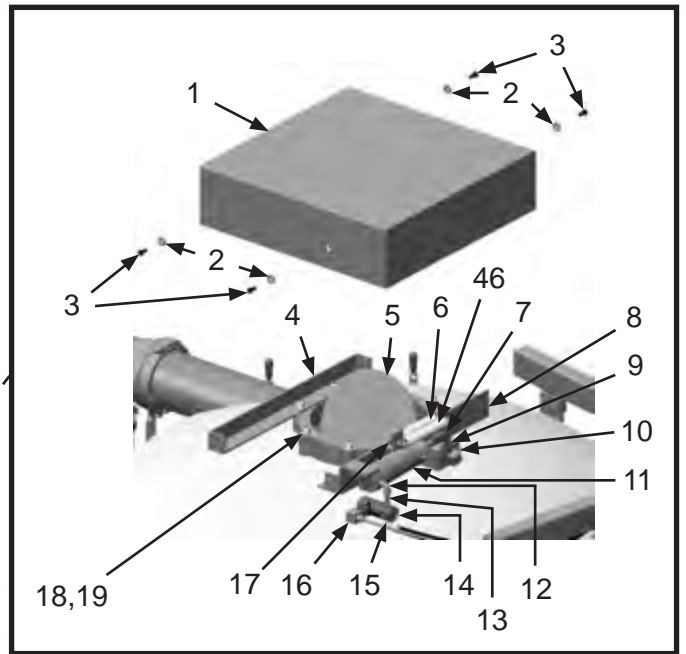
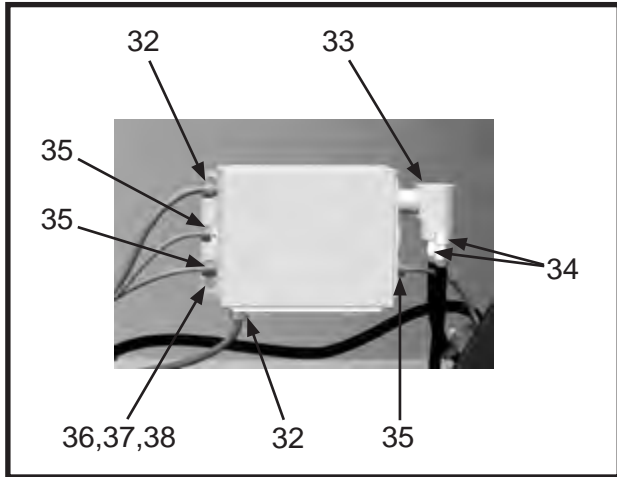

## PART NUMBERS AND SCHEMATICS

### Left Side Front Assembly

Item #	Part #	Description
<b>Fig. 6</b>		
1	10104457	Intake Filter Housing <i>(See Figure 11)</i>
2	10104640	6" Double Bolt Clamp
3	10104704	116 Gallon Rectangle Fuel Tank <i>(See Figure 9)</i>
4	10104082	Jack Stand <i>(Four Required)</i>
5	10103342	Battery Box
6	10104273	Document Holder
7	10104608	Support Arm
8	10105896	Tool Box
9	10103440R	3/4-10 UNC GR8 Draw Bolt <i>(Two Required)</i>
10	10103418	Washer - 3/4" - Grade 8 <i>(Four Required)</i>
11	10103420	3/4-10 UNC Grade 8 Nut <i>(Four Required)</i>
12	10101943	1/2-13 x 1-3/4" Hex Bolt <i>(12 Required)</i>
13	10100674	1/2" Flat Washer <i>(24 Required)</i>
14	10100675	1/2" Lock Washer <i>(12 Required)</i>
15	10101941	1/2-13 Hex Nut - <i>(12 Required)</i>
16	10101927	1/2-13 x 3" Galvanized Hex Bolt <i>(Four Required)</i>
17	10104584	Silencer Mount Weldment
18	10104708	1/4-28 Straight Grease Zerk
19	10106402	5/8-11 Grease Zerk Thru Bolt
20	10106403	3/16" x 5/8" Dowel Pin
21	10101061	5/8" Lock Washer
22	10104600	Vacuum Pin Cap
23	10104602	Vacuum Shoulder Pin
24	10104824	8" Raincap
—	10103343	Battery Cables, 156" Long
—	10103341	Battery <i>(not shown)</i>



# PART NUMBERS AND SCHEMATICS

Figure 6: Left Side Front Assembly

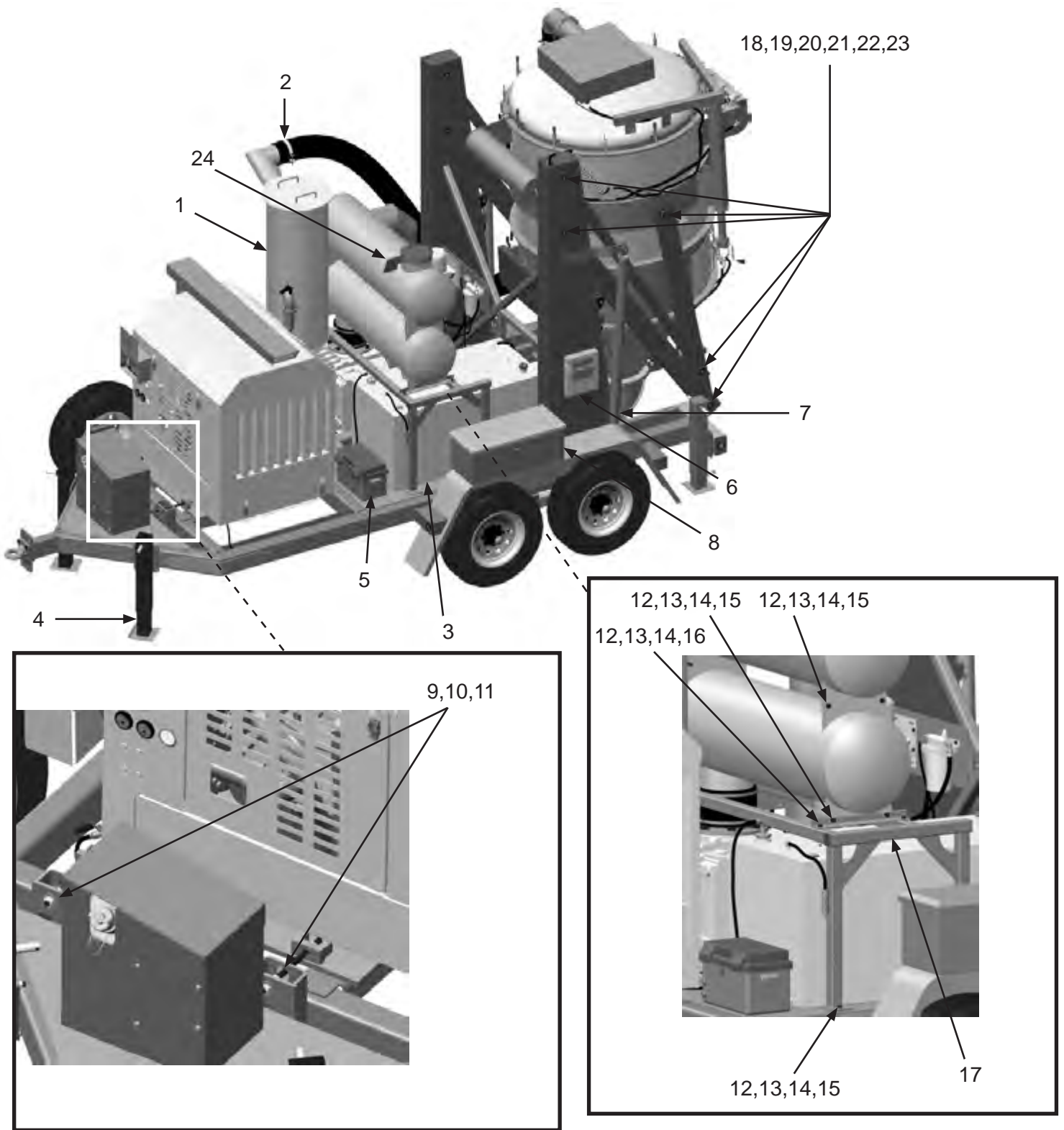

## PART NUMBERS AND SCHEMATICS

### Left Side Rear Assembly

Item #	Part #	Description
<b>Fig. 7</b>		
1	10104234	3/8-16 x 1-1/4" Hex Bolt Zinc <i>(Eight Required)</i>
2	10101942	3/8" Flat Washer - Galvanized <i>(40 Required)</i>
3	10101936	3/8" Lock Washer - Zinc <i>(11 Required)</i>
4	1012318	3/8-16 Hex Nut <i>(11 Required)</i>
5	10104472	Vacuum Lid Lift
6	10104434	Vacuum Top Section
7	10104638	Bulldog Trailer Jack
8	10104728	Lift Arm Support Bracket <i>(Two Required)</i>
9	10104729	Lift Arm Support Bracket Pin <i>(Two Required)</i>
10	10104608	Support Arm Outer <i>(Two Required)</i>
—	10104605	Support Arm Inner <i>(Two Required) (not shown)</i>
11	10103308	Elbow - 90° - JIC 8 x SAE 10 <i>(Four Required)</i>
12	10104645	Hopper Lift Cylinders <i>(Two Required)</i>
13	10104646	Lift Cylinder Clevis <i>(Two Required)</i>
14	10104647	1" x 3-1/8" Pin <i>(Two Required)</i>
15	10105290	3/16" x 1-5/8" Pin
16	10104486	Over Center Clamp <i>(12 Required)</i>

# PART NUMBERS AND SCHEMATICS

Figure 7: Left Side Rear Assembly

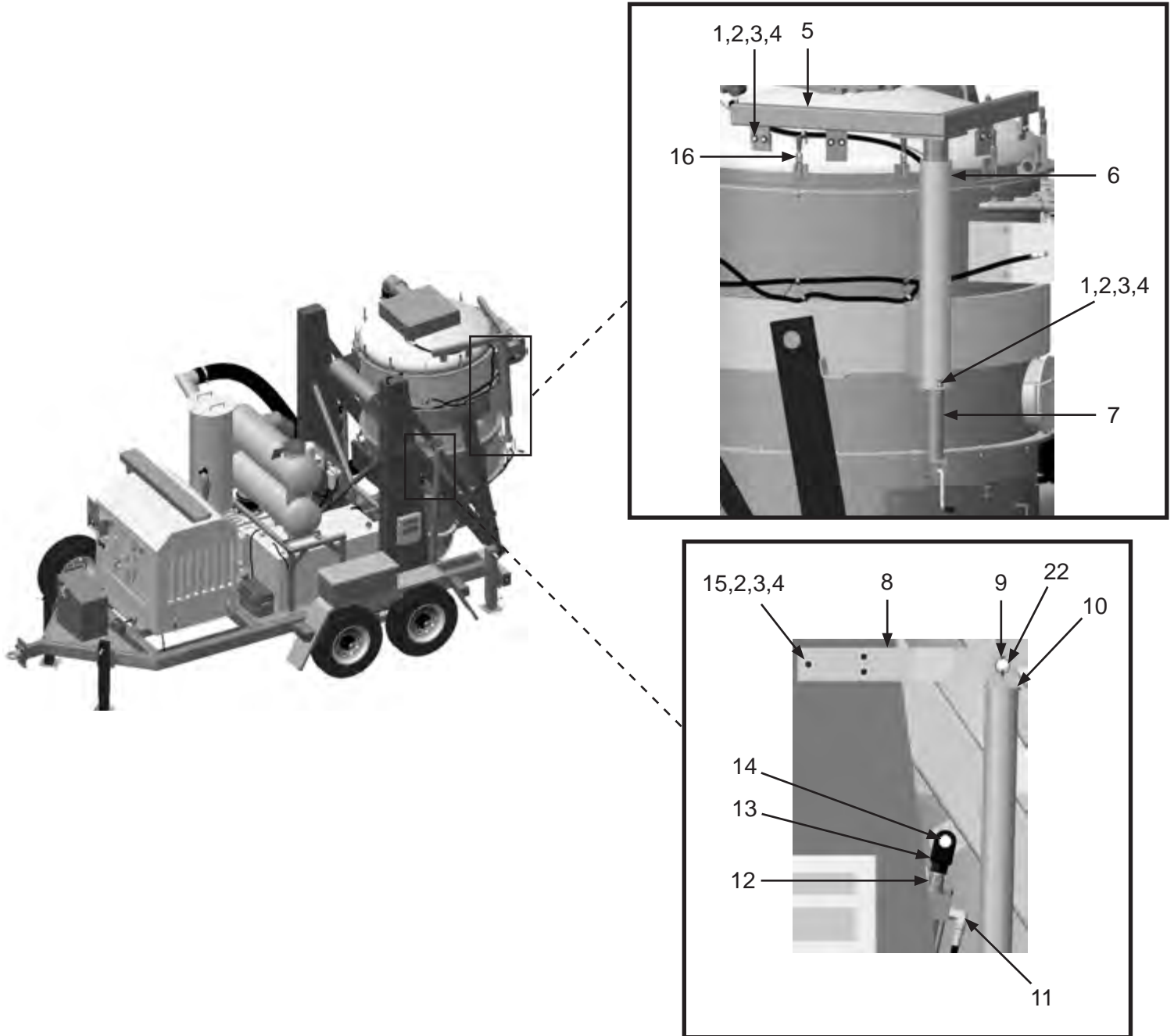

## PART NUMBERS AND SCHEMATICS

**Figure 8: Double Lock Valve Assembly**

Item #	Part #	Description
<b>Fig. 8</b>		
1	10104650	Double Lock Valve
2	10103309	Elbow - 90° - JIC 8 x SAE 8 <i>(Two Required)</i>
3	10105081	JIC 8 Tee <i>(Two Required)</i>
4	10104651	Union - Straight SAE 8 x JIC 8 <i>(Two Required)</i>
5	10103613	Union - Straight SAE 8 x SAE 8
6	10105288	Flow Restrictor SAE 8
7	10105286	5/16-18 x 2-1/2" Grade 5 Zinc Bolt <i>(Two Required)</i>
8	10L805014	5/16" Lock Washer <i>(Two Required)</i>
9	1035046	5/16-18 Nut <i>(Two Required)</i>

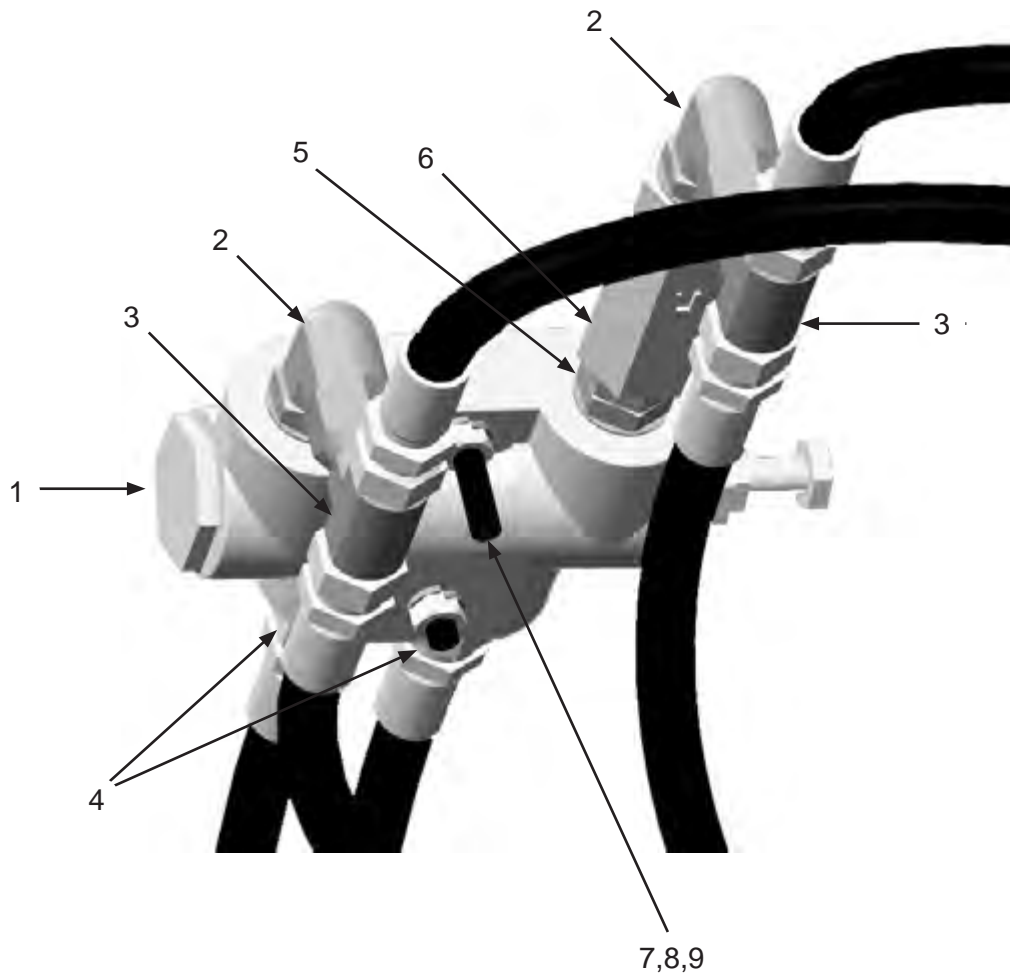

## PART NUMBERS AND SCHEMATICS

Figure 9: Fuel Tank

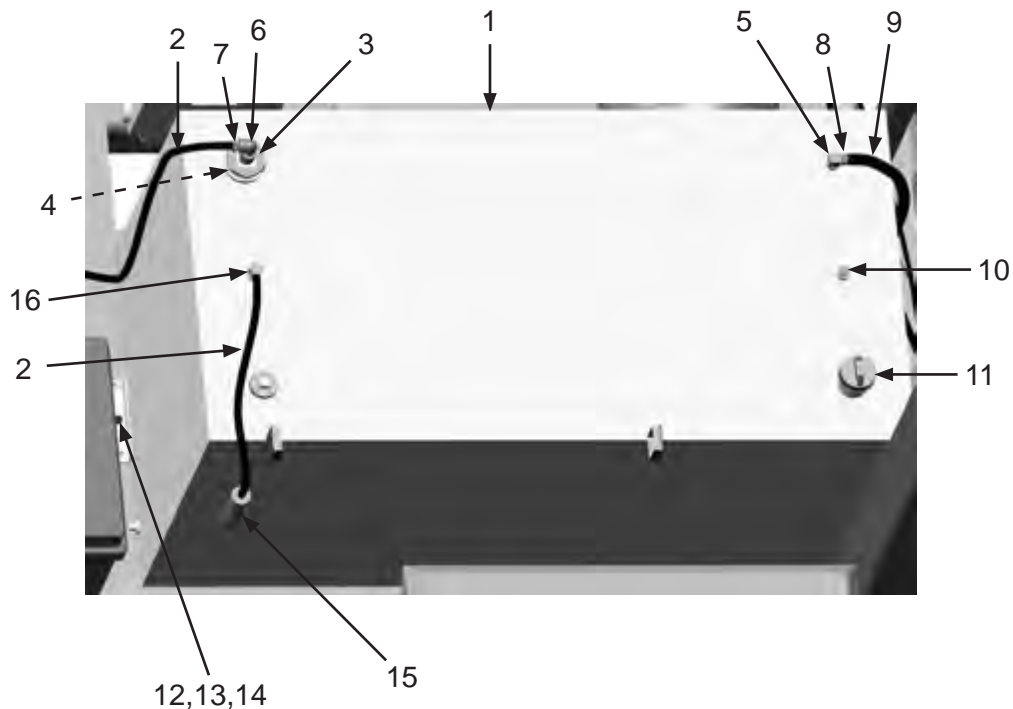

Item #	Part #	Description
<b>Fig. 9</b>		
1	10104704	116 Gallon Rectangle Fuel Tank
2	10103423	3/8" I.D. Fuel Hose ( <i>Per Foot</i> )
3	10106484	Fuel Return Adapter
4	10106466	3/8" NPT x 18" Pipe Nipple - 304 Stainless Steel
5	10103617	Withdraw Tube - 16"
6	10106470	3/8" NPT Street Elbow - 304 Stainless Steel
7	10106469	3/8" Hose Barb x 3/8" NPT - 304 Stainless Steel
8	10106503	3/8" NPT x 1/2" Hose Barb - 304 Stainless Steel
9	10103619	1/2" Flexible Fuel Line ( <i>Per Foot</i> )
10	10106502	3/8" NPT Plug - 304 Stainless Steel
11	10103968	Locking Fuel Cap with Keys
12	10104234	3/8-16 x 1-1/4" Hex Bolt Zinc ( <i>Two Required</i> )
13	10101942	3/8" Flat Washer - Galvanized ( <i>Two Required</i> )
14	10101938	3/8-16 Hex Nut - Galvanized
15	10103620	3/8" Inline Filter
16	20PFHA60UA0606	3/8" (M) x 3/8" (F) 90° Swivel Union
—	10104631	Fuel Tank Rubber Cushioning Pad ( <i>not shown</i> )

## PART NUMBERS AND SCHEMATICS

Figure 10: Fan Belt Assembly

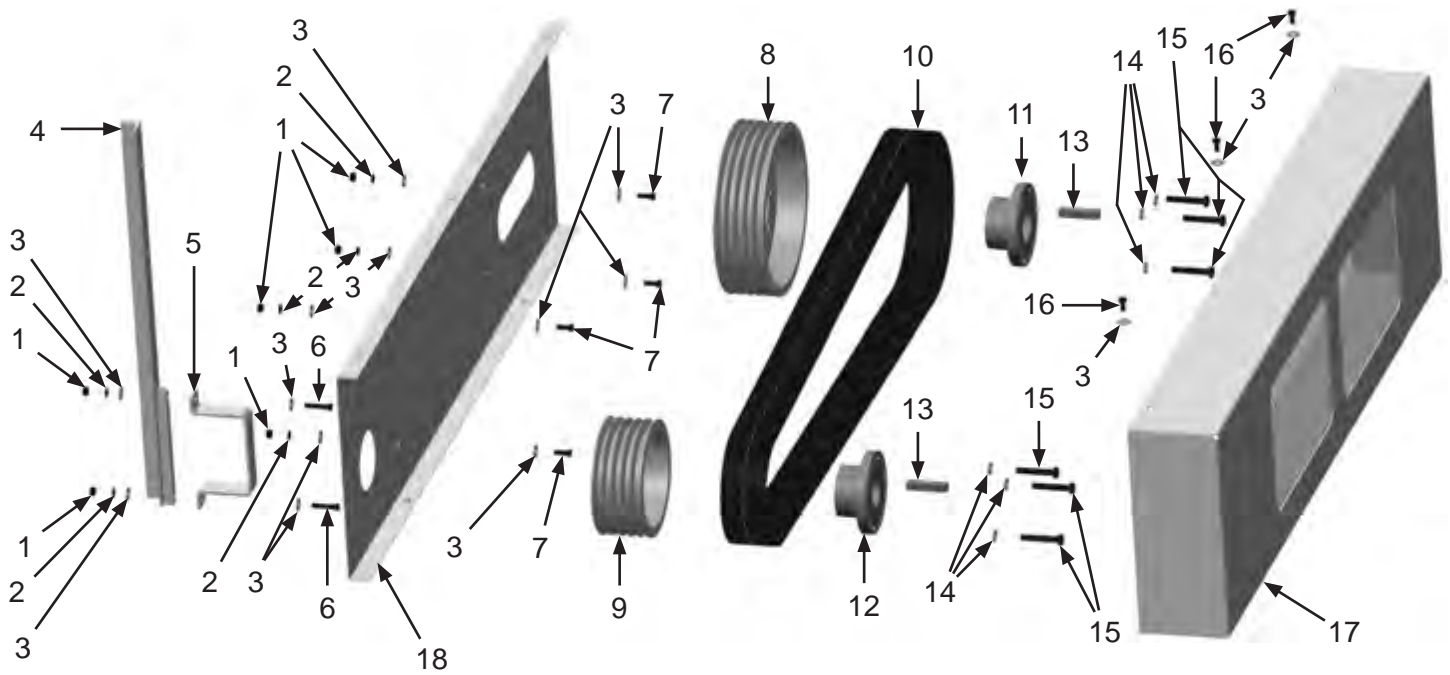

Item #	Part #	Description
--------	--------	-------------

**Fig. 10**

1	1012318	3/8" Galvanized Hex Nut (Four Required)
2	10101936	3/8" Zinc Lock Washer (Four Required)
3	10101942	3/8" Galvanized Flat Washer (15 Required)
4	10104573	Vacuum Belt Guard Mount
5	10104576	Belt Guard Clamp
6	1028617	3/8-16 x 1-3/4" Shoulder Bolt (Two Required)
7	1011747	3/8-16 x 1" Bolt (Four Required)
8	10104641	12.5" 5V 5 Groove Sheave
9	10104642	8.5" 5V 5 Groove Sheave
10	10104644	5VX 1180 Banded Belt
11	10103485	Bushing 2.5" Bore
12	10104643	Bushing 2" Bore
13	10103643	5/8" Key Cut (Two Required)
14	10100675	1/2" Lock Washer (Six Required) (Included with Item 12)
15	10102820	1/2-13 x 2-3/4" Grade 5 Bolt (Six Required) (Included with Item 12)
16	10103400	3/8-16 x 3/4" Bolt (Three Required)
17	10104579	Belt Guard Cover
18	10104577	Belt Guard Back

## PART NUMBERS AND SCHEMATICS

Figure 11: Intake Filter Housing

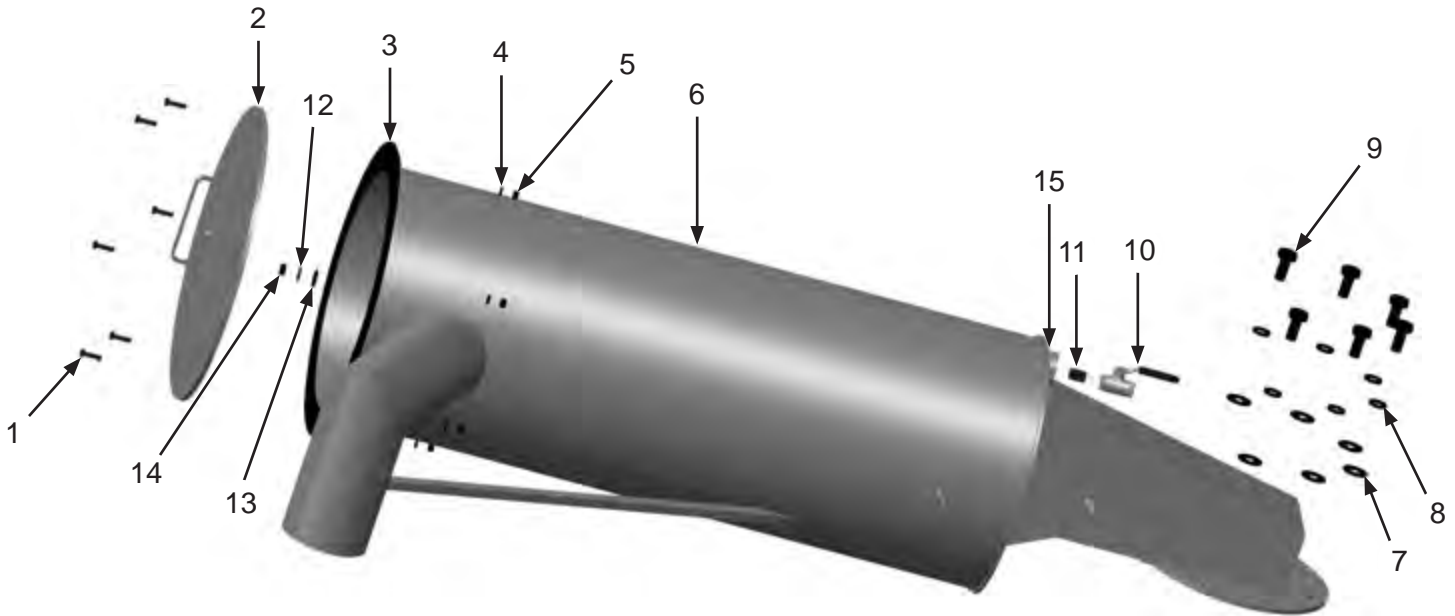

Item #	Part #	Description
--------	--------	-------------

**Fig. 12**

1	10104234	3/8-16 x 1-1/4" Hex Bolt Zinc ( <i>Six Required</i> )
2	10106508	Intake Filter Housing Cap
3	10104727	Air Filter Housing Gasket
4	10101936	3/8" Lock Washer - Zinc ( <i>Four Required</i> )
5	10101938	3/8-16 Hex Nut - Galvanized ( <i>Four Required</i> )
6	10107984	Intake Filter Housing
7	10100704	3/4" Flat Washer ( <i>Six Required</i> )
8	10100596	3/4" Lock Washer ( <i>Six Required</i> )
9	10104714	3/4-10 x 1-5/8" Zinc Bolt ( <i>Six Required</i> )
10	10L363	1/2" NPT Full Port Ball Valve
11	10L803035	1/2" Close Nipple Galvanized
12	10100674	1/2" Flat Washer
13	10102005	Rubber Washer 1.25 O.D. x .375 I.D. x .13
14	10101941	1/2-13 Hex Nut - Galvanized
15	1011820	1-1/4" x 1/2" Bushing - Galvanized
—	10102253	Filter Cartridge

## PART NUMBERS AND SCHEMATICS

Figure 12: Vacuum Light Bar

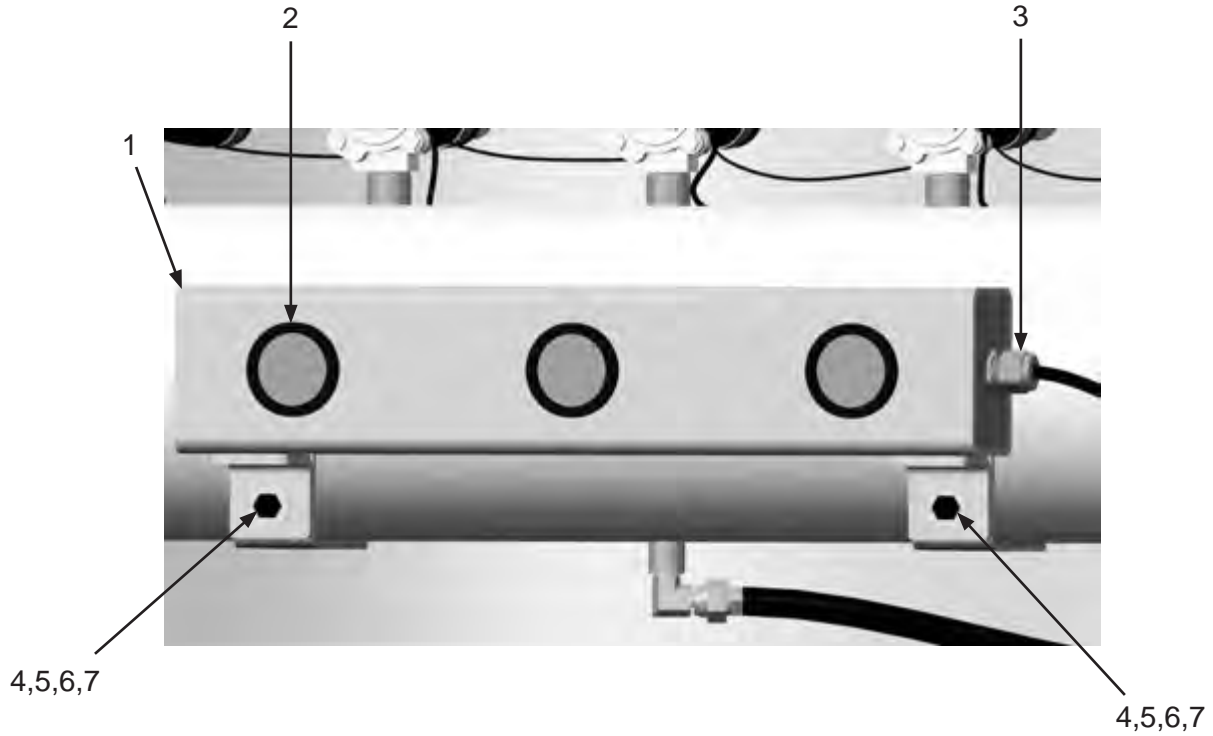

Item #	Part #	Description
--------	--------	-------------

**Fig. 12**

1	10105334	Vacuum Light Bar (Includes Item #2)
2	10104086	2" Round LED Red Clearance Light (Three Required)
3	10104703	Cord Grip, Nylon 1/2" NPT .2-.47 Diameter
4	10101942	3/8" Flat Washer - Galvanized (Four Required)
5	10101936	3/8" Lock Washer - Zinc (Two Required)
6	1011747	3/8-16 x 1" Bolt (Two Required)
7	1012318	3/8-16 Hex Nut (Two Required)



## PART NUMBERS AND SCHEMATICS

Figure 13: Pneumatic Piston Vibrators

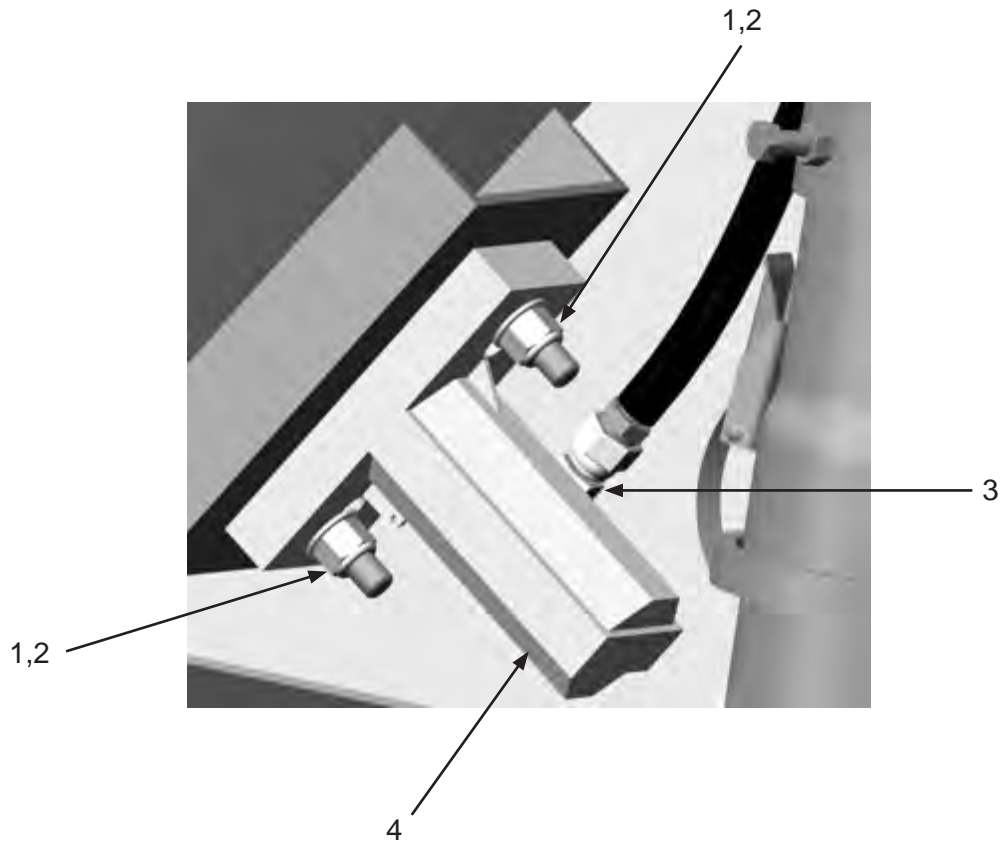

Item #	Part #	Description
<b>Fig. 13</b>		
1	20100124	1/2-13 Hex Lock Nut - Zinc ( <i>Two Required</i> )
2	10100674	1/2" Flat Washer ( <i>Two Required</i> )
3	20PFHA60UA0406	1/4" (M) x 3/8" (F) 90° Swivel Union
4	10104665	APV Series Piston Vibrator

# PART NUMBERS AND SCHEMATICS

## Pulser System Assembly

Item #	Part #	Description
<b>Fig. 14</b>		
1	10101942	3/8" Flat Washer - Galvanized <i>(Eight Required)</i>
2	10101936	3/8" Lock Washer - Zinc <i>(Four Required)</i>
3	1011747	3/8-16 x 1" Bolt <i>(Four Required)</i>
4	10101938	3/8-16 Hex Nut <i>(Four Required)</i>
5	20PFHA60UA0606	3/8" (M) x 3/8" (F) 90° Swivel Union
6	10104498	Vacuum Header
7	10103736	T-Bolt Hose Clamp For 1" I.D. <i>(10 Required)</i>
8	10106509	1" 75W Marine Hose - 100 PSI
9	10104500	3/4" NPT x 1-1/2" Toe Nipple <i>(Five Required)</i>
10	10105287	Din Connector <i>(Included with Item #16) (Five Required)</i>
11	10104666	3/4" Diaphragm Valve with Solenoid <i>(Five Required)</i>
—	10107192	Pilot Valve Repair Kit
—	10107193	Diaphragm Repair Kit

# PART NUMBERS AND SCHEMATICS

Figure 14: Pulser System Assembly

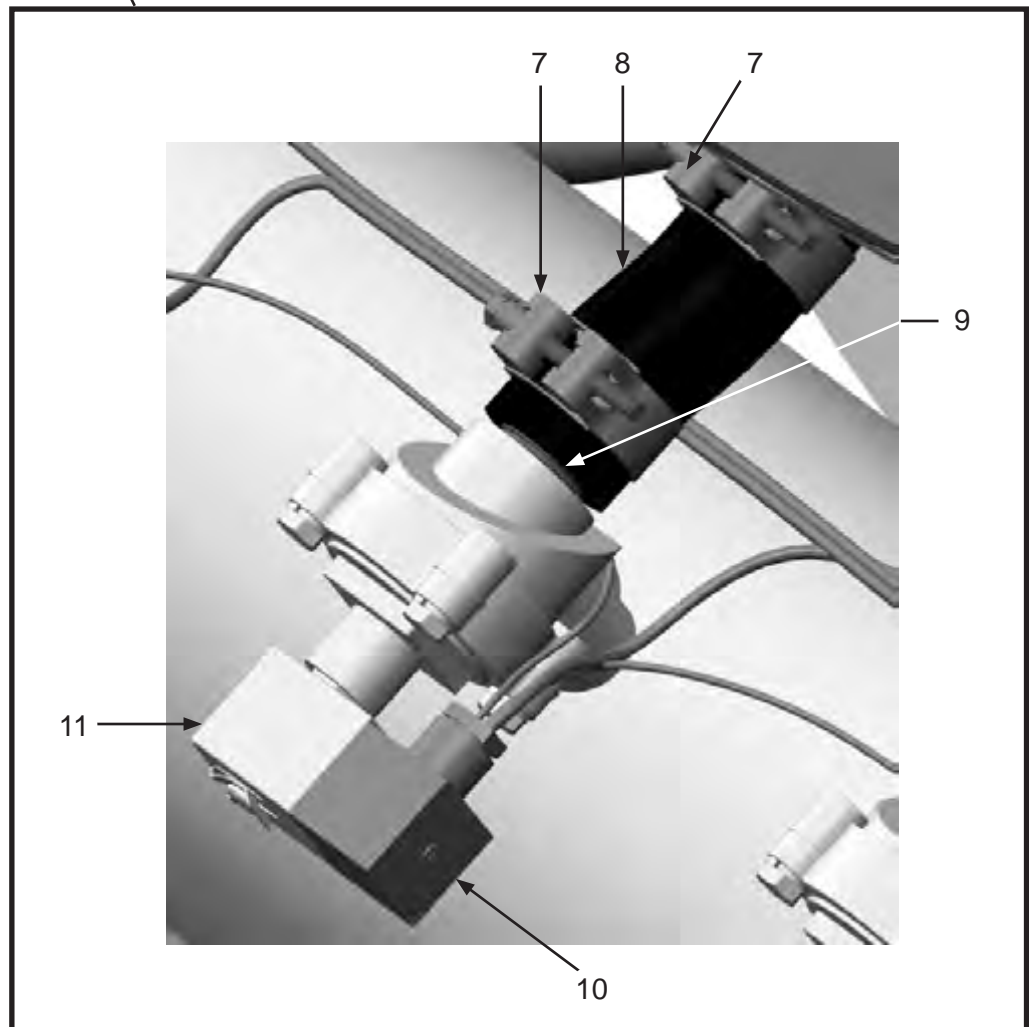
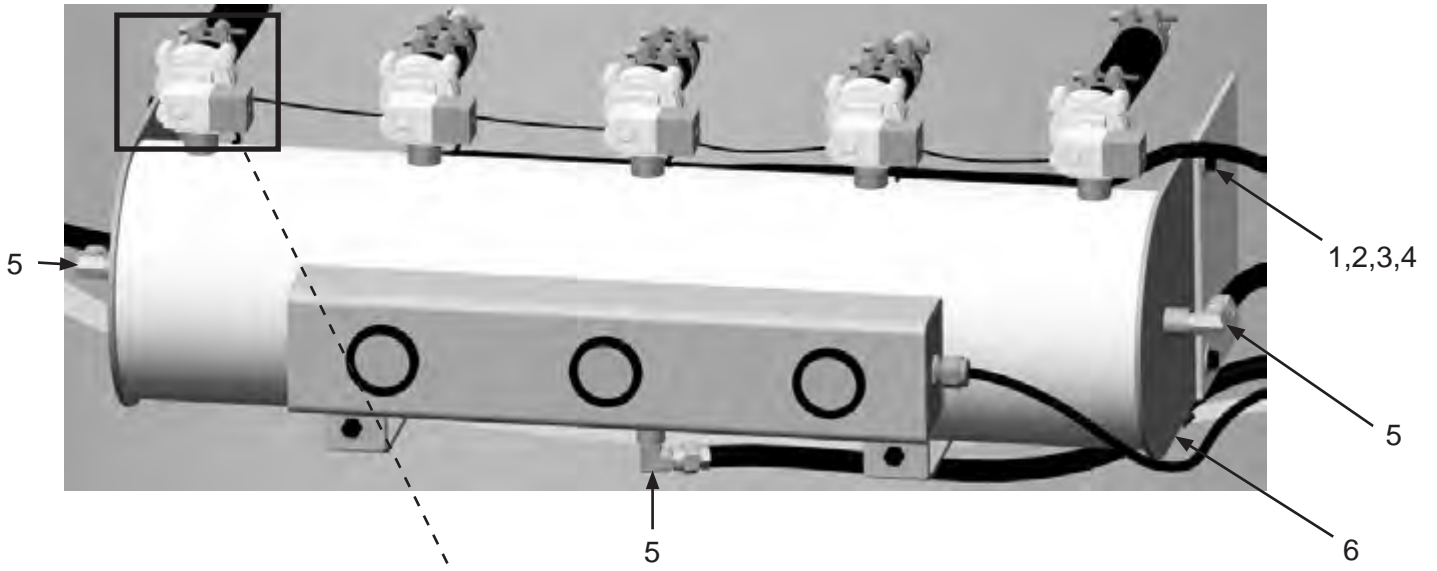

## PART NUMBERS AND SCHEMATICS

Figure 15: Filter Bag Pulsers

Item #	Part #	Description
<b>Fig. 15</b>		
1	10103736	T-Bolt Hose Clamp For 1" I.D. <i>(10 Required)</i>
2	10106509	1" 75W Marine Hose - 100 PSI
3	10104562	Pulsar System Short Blowpipe <i>(Two Required)</i>
4	10104565	Pulsar System Medium Blowpipe <i>(Two Required)</i>
5	10104680	1" Flexible Tubing For Blowpipes <i>(Two Required)</i>
6	10104567	Pulsar System Long Blowpipe <i>(Three Required)</i>
7	10104633	Vacuum Baghouse Filter <i>(37 Required)</i>
—	10104634	Vacuum Baghouse Filter Cage <i>(37 Required)</i>

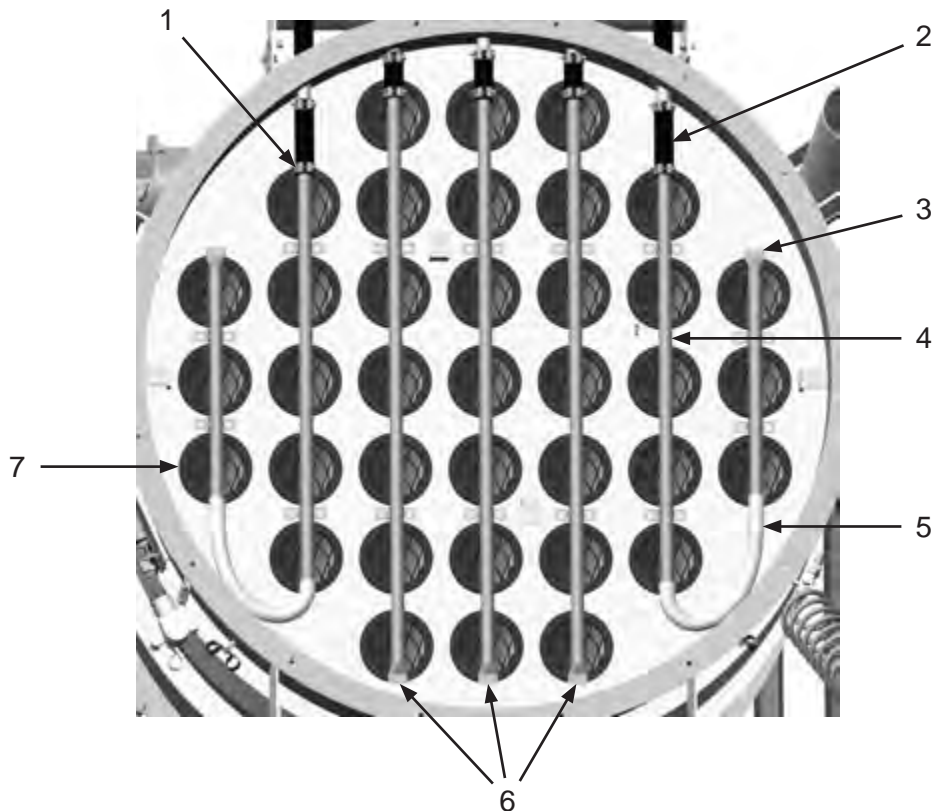

## PART NUMBERS AND SCHEMATICS

Figure 16: Emergency-Stop Station

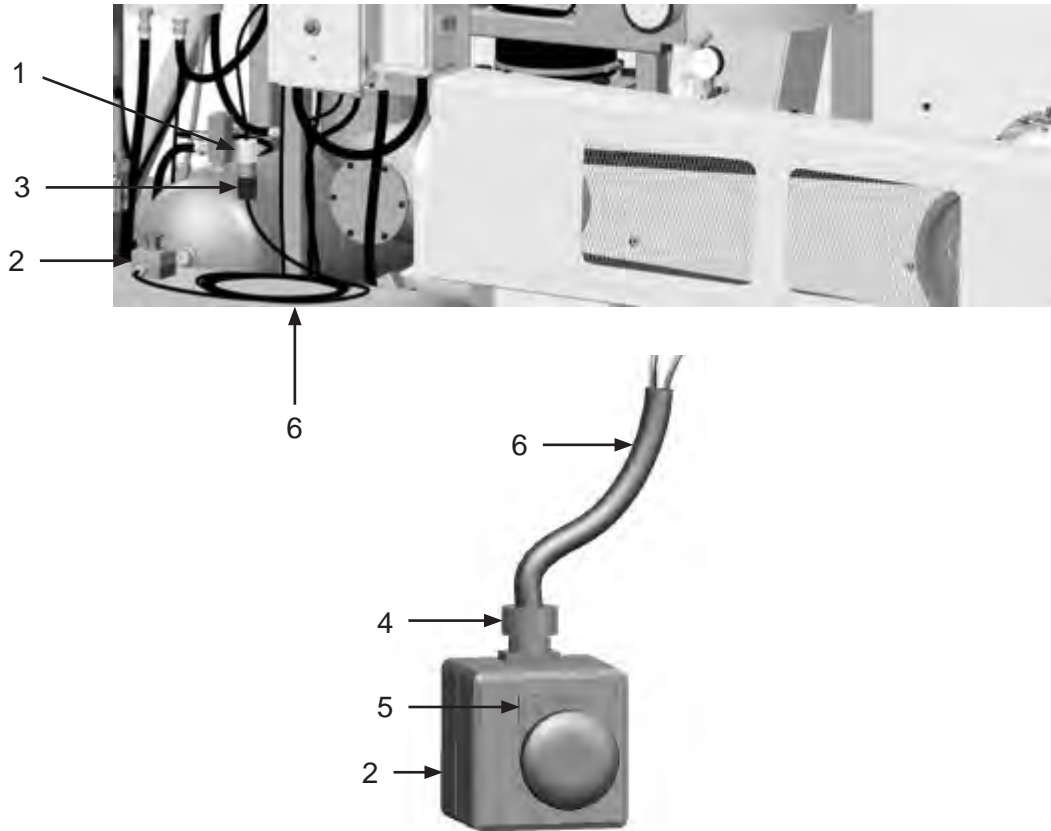

Item #	Part #	Description
--------	--------	-------------

Fig. 16

—	<b>10107200</b>	<b>Remote Emergency-Stop Station</b> <i>(Includes Item #'s: 2, 4, 5, and 6 (100'))</i>
1	1015552	Female Twist Lock Plug Two Prong
2	10104071	E-Stop Control Station
3	1015551	Male Twist Lock Plug Two Prong
4	10104703	Cord Grip, Nylon 1/2"-NPT .2-.47 Diameter
5	10104063	Legend Plate - Emergency Stop
6	1015540	16/2 Xtreme Duty Power Cord - Red
—	1015009	8-32 x 1" Pan Head Phillips Screw <i>(Four Required)</i>
—	20000021	8-32 Zinc Nut <i>(Four Required)</i>
—	20000018	#8 Zinc Lock Washer <i>(Four Required)</i>
—	20000019	#8 Zinc Flat Washer <i>(Four Required)</i>

# PART NUMBERS AND SCHEMATICS

## Compressor Assembly

Item #	Part #	Description
<b>Fig. 17</b>		
—	<b>10106612</b>	<b>Compressor Assembly</b>
1	10106030	Compressor to PTO Adapter
2	10106031	M8 x 80MM Bolt ( <i>Four Required</i> )
3	10106032	SAE A O-Ring
4	10101062	5/8-11 Hex Nut
5	10101061	5/8" Lock Washer
6	10106033	Compressor Gear
7	10106034	Compressor Body
8	10106035	SAE A 2-Bolt Cover With O-ring
9	10106036	M8 x 16MM Bolt ( <i>Two Required</i> )
10	20PFHA60SA0204	1/8" (M) x 1/4" (F) Swivel Union
11	10106037	M8 x 25MM Bolt ( <i>Two Required</i> )
12	10106042	PTO O-ring
13	10101941	1/2-13 Hex Nut ( <i>Two Required</i> )
14	10106038	Metric Straight to NPT
15	10103615	M10 x 25MM Zinc Bolt ( <i>Two Required</i> )
16	10106039	Compressor Bracket
17	10101002	1/2" x 1" 90° Elbow
18	10106040	Metric Straight To 1/2" Hose Barb ( <i>Two Required</i> )
19	10PAF025	1/4" x 1/4" Push on Fitting
20	20PFHA60UA0808	1/2" (M) x 1/2" (F) 90° Swivel Union
21	10000057	1/2" x 1/2" Street Elbow ( <i>Two Required</i> )
22	10L803035	Nipple
23	10105870	Filter Assembly
24	10106041	Metric Straight to NPT
—	10106362	5 Micron Filter Element ( <i>Replacement Filter for 10105870</i> )

# PART NUMBERS AND SCHEMATICS

Figure 17: Compressor Assembly

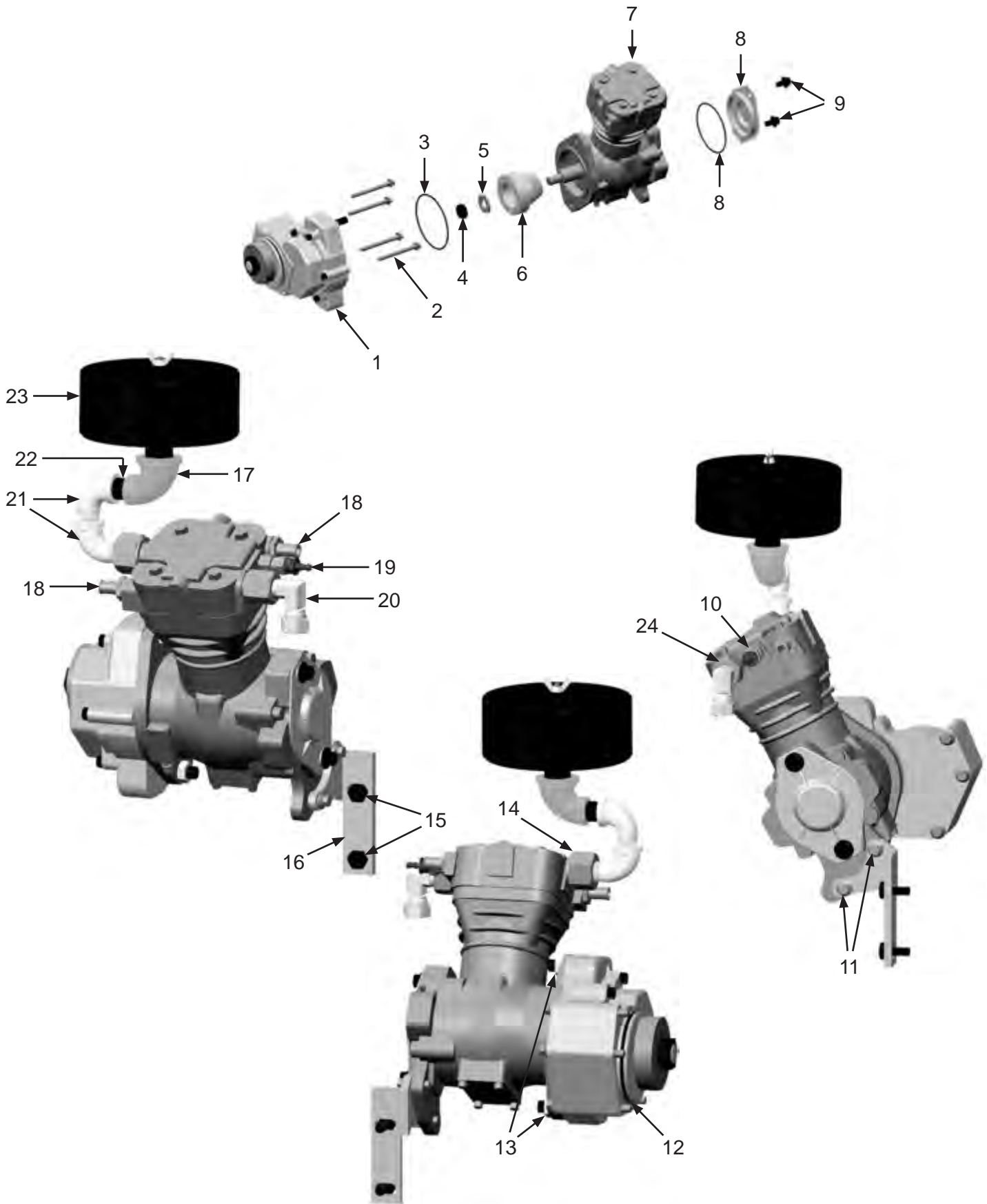

## PART NUMBERS AND SCHEMATICS

Figure 18: Compressor Governor

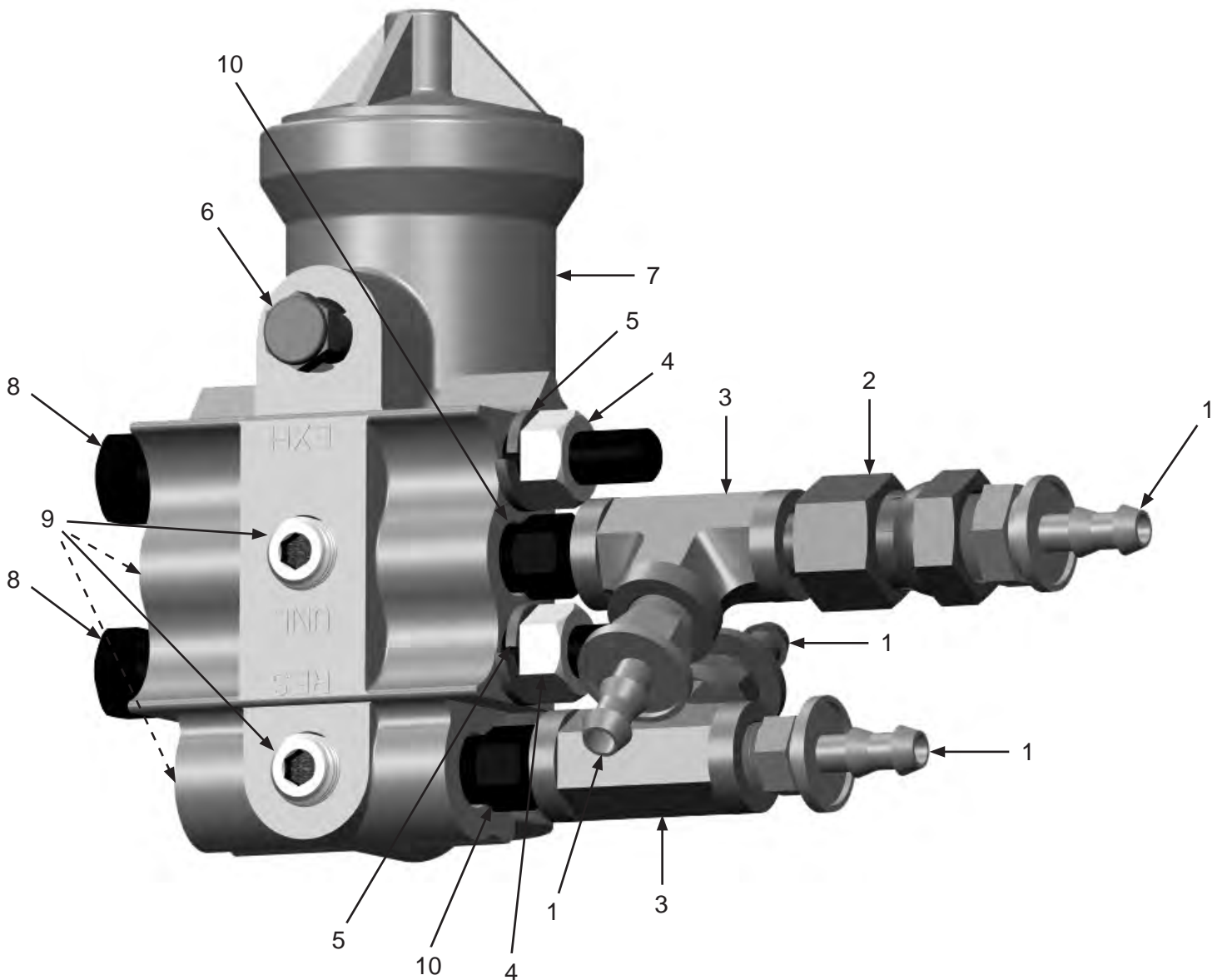

Item #	Part #	Description
<b>Fig. 18</b>		
1	10PAF025	1/4" x 1/4" Push-On Fitting (Four Required)
2	20PFHA60SA0204	1/8" (M) x 1/4" (F) Swivel Union
3	20PFHA25VJ02	1/8" Female Tee (Two Required)
4	1035046	5/16-18 Nut (Two Required)
5	10L805014	5/16" Lock Washer (Two Required)
6	1012905	1/8" Breather Muffler
7	10105816	Compressor Governor
8	1014112	5/16-18 x 3-1/4" Hex Bolt (Two Required)
9	10105717	1/8" Hollow Hex Pipe Plug Male (Four Required)
10	20PFHA24SA0202	1/8" Hex Nipple (Two Required)



## PART NUMBERS AND SCHEMATICS

Figure 19: Vacuum Hose Support Bracket

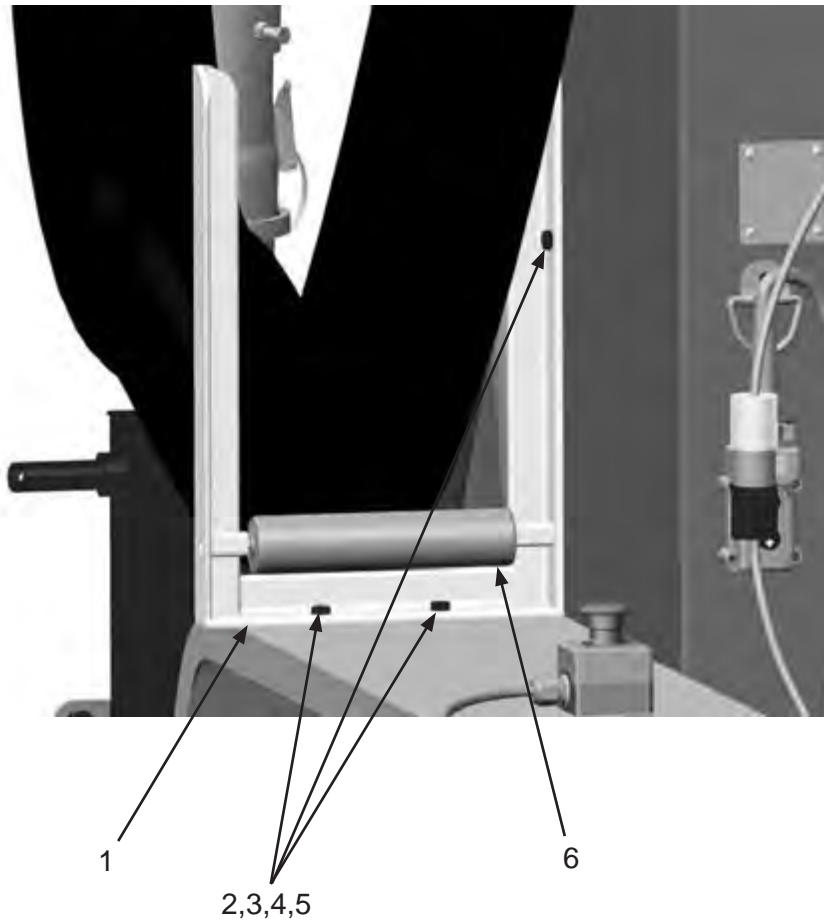

Item #	Part #	Description
--------	--------	-------------

**Fig. 19**

1	10105264	Vacuum Hose Bracket
2	1011747	3/8-16 x 1" Bolt – Zinc ( <i>Three Required</i> )
3	10101942	3/8" Flat Washer – Galvanized ( <i>Three Required</i> )
4	10101936	3/8" Lock Washer – Zinc ( <i>Three Required</i> )
5	10101938	3/8-16 Hex Nut – Galvanized ( <i>Three Required</i> )
6	10106374	1.9" Diameter Conveyor Roller – 9" Long

## PART NUMBERS AND SCHEMATICS

### Trailer

Item #	Part #	Description
<b>Fig. 20</b>		
—	<b>10104455</b>	<b>7 Ton Double Axle Trailer</b>
1	10104082	10,000# Heavy Spring Loaded Jack <i>(Four Required)</i>
2	10104087	2" Round LED Amber Clearance Light <i>(Two Required)</i>
3	10104088	2" Round Rubber Grommet <i>(Six Required)</i>
4	10104089	16" - 8 Hole Pattern Rim with Tire <i>(Four Required)</i>
5	10106084	7,000# Axle With Electric Brakes, Complete with Hubs and Springs 89" HF x 71" SC
6	10104079	Pintle Hitch with Flat Plate
7	10104085	Oval Rubber Grommet <i>(Two Required)</i>
8	10104084	Oval LED Red Tail Light <i>(Two Required)</i>
9	10104086	2" Round LED Red Clearance Light <i>(Four Required)</i>
10	10106086	Axle Hub Only – No Bearings or Seal <i>(Two Required)</i>
11	10106088	Right-Hand Electric Brake Assembly <i>(Two Required)</i>
12	10106087	Left-Hand Electric Brake Assembly <i>(Two Required)</i>
13	10104096	Tire – ST235/85R/16 – 14-ply <i>(Four Required)</i>
14	10106085	Axle Beam/Tube Only
15	10105746	5/8 x 2-1/2" Grade 8 Bolt <i>(16 Required)</i>
16	10105747	5/8" Reverse Lock Nut <i>(16 Required)</i>
17	10103398	5/8" Flat Washer <i>(40 Required)</i>
18	10103397	5/8" x 2" Grade 8 Bolt <i>(Four Required)</i>
19	10103393	5/8" Reverse Lock Nut <i>(Four Required)</i>
20	10107126	16" x 6" - 8-Hole White Rim
—	10105826	Redline 12V - 5AH Battery Sealed
—	10104081	Breakaway Kit
—	10104142	Wire Harness – Complete <i>(Front, Middle &amp; Rear)</i>
—	10105827	Breakaway Switch with Pin
—	10104769	3/8" x 41" Safety Chain with Hook
—	10103879	2" x 6" x 6" Red/White Conspicuity Tape
—	10105829	Cable with Plug
—	10107329	Sidewind Crank

# PART NUMBERS AND SCHEMATICS

Figure 20: Trailer

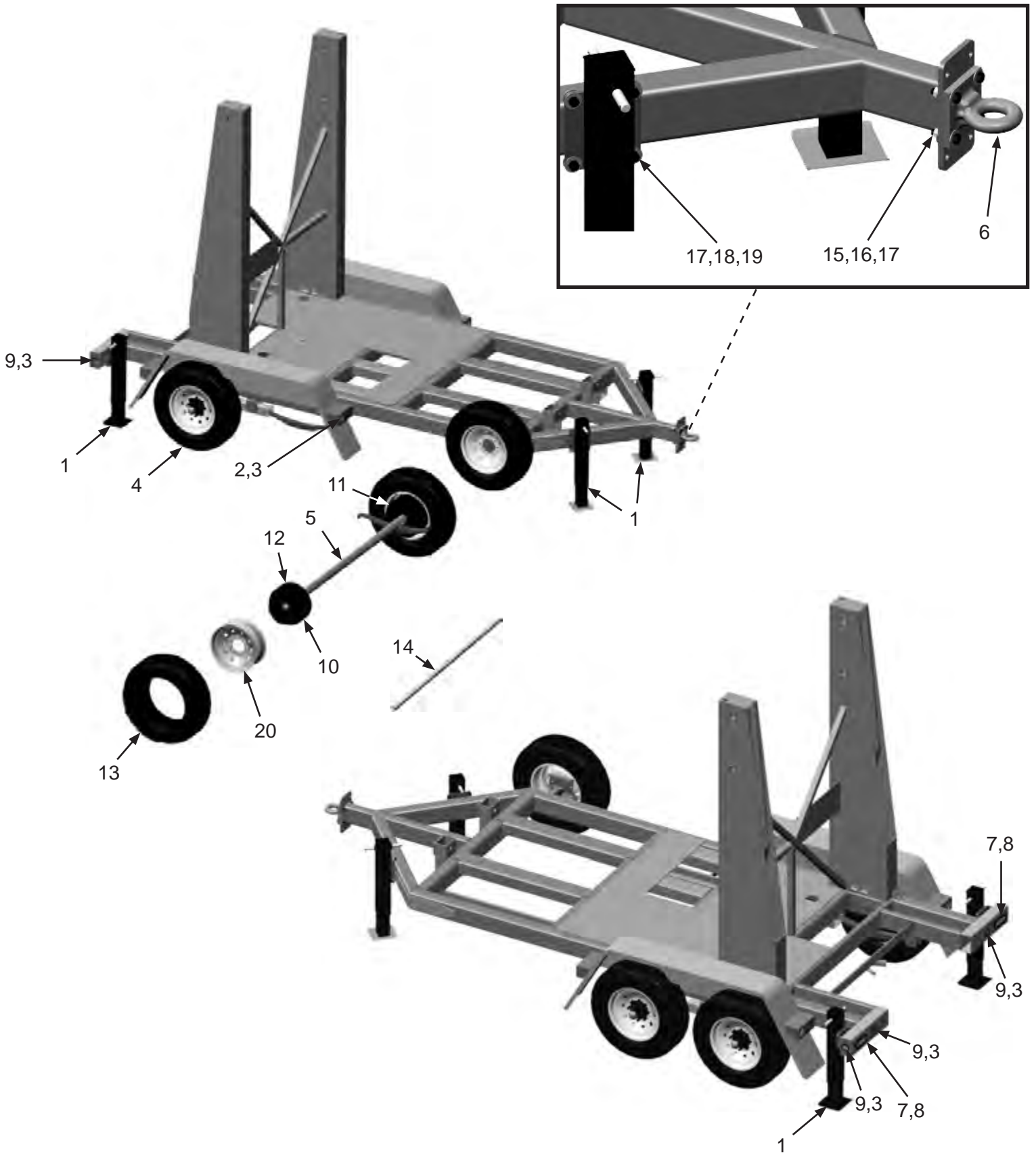

## PART NUMBERS AND SCHEMATICS

### Wear Plates and Baffles

Item #	Part #	Description
<b>Fig. 21</b>		
1	10101942	3/8" Flat Washer - Galvanized <i>(35 Required)</i>
2	10101936	3/8" Lock Washer - Zinc <i>(35 Required)</i>
3	10101938	3/8-16 Hex Nut <i>(35 Required)</i>
4	1011747	3/8-16 x 1" Bolt <i>(15 Required)</i>
5	10104489	Vacuum Wear Plates <i>(Four Required)</i>
6	10104490	Vacuum Baffle <i>(Three Required)</i>
7	10104705	3/8-16 x 1" Bolt Zinc <i>(16 Required)</i>

# PART NUMBERS AND SCHEMATICS

Figure 21: Wear Plates and Baffles

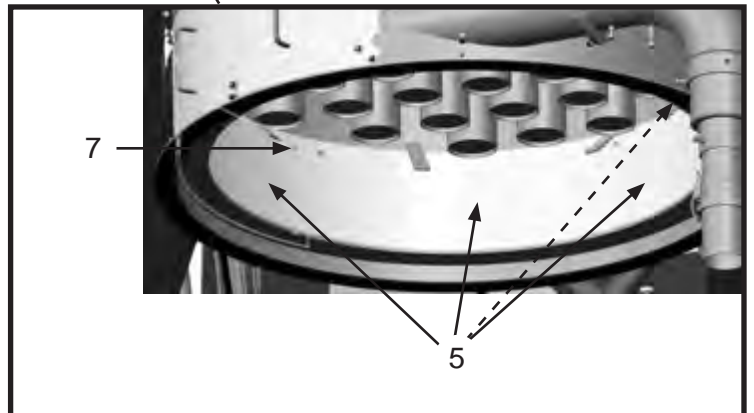
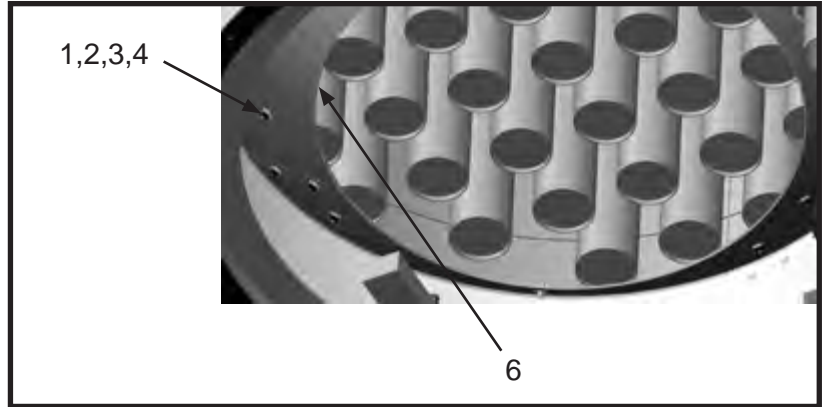
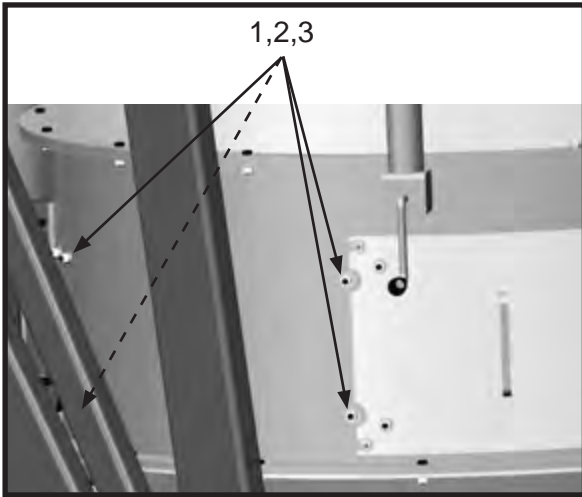

# PART NUMBERS AND SCHEMATICS

**Figure 22: Hydraulic Hoses**

Item #	Part #	Description
1	10104664	Hydraulic Hose – 3/8" I.D. x 8' – 2600 PSI
2	10104663	Hydraulic Hose – 3/8" I.D. x 5' – 2600 PSI

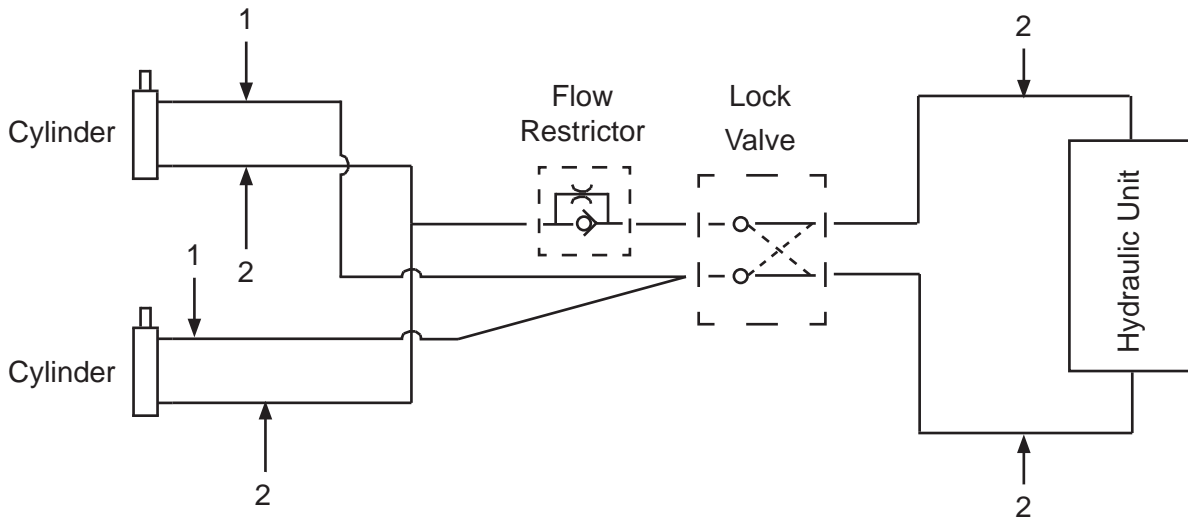

# PART NUMBERS AND SCHEMATICS

Figure 23: Hazard Identification Decals

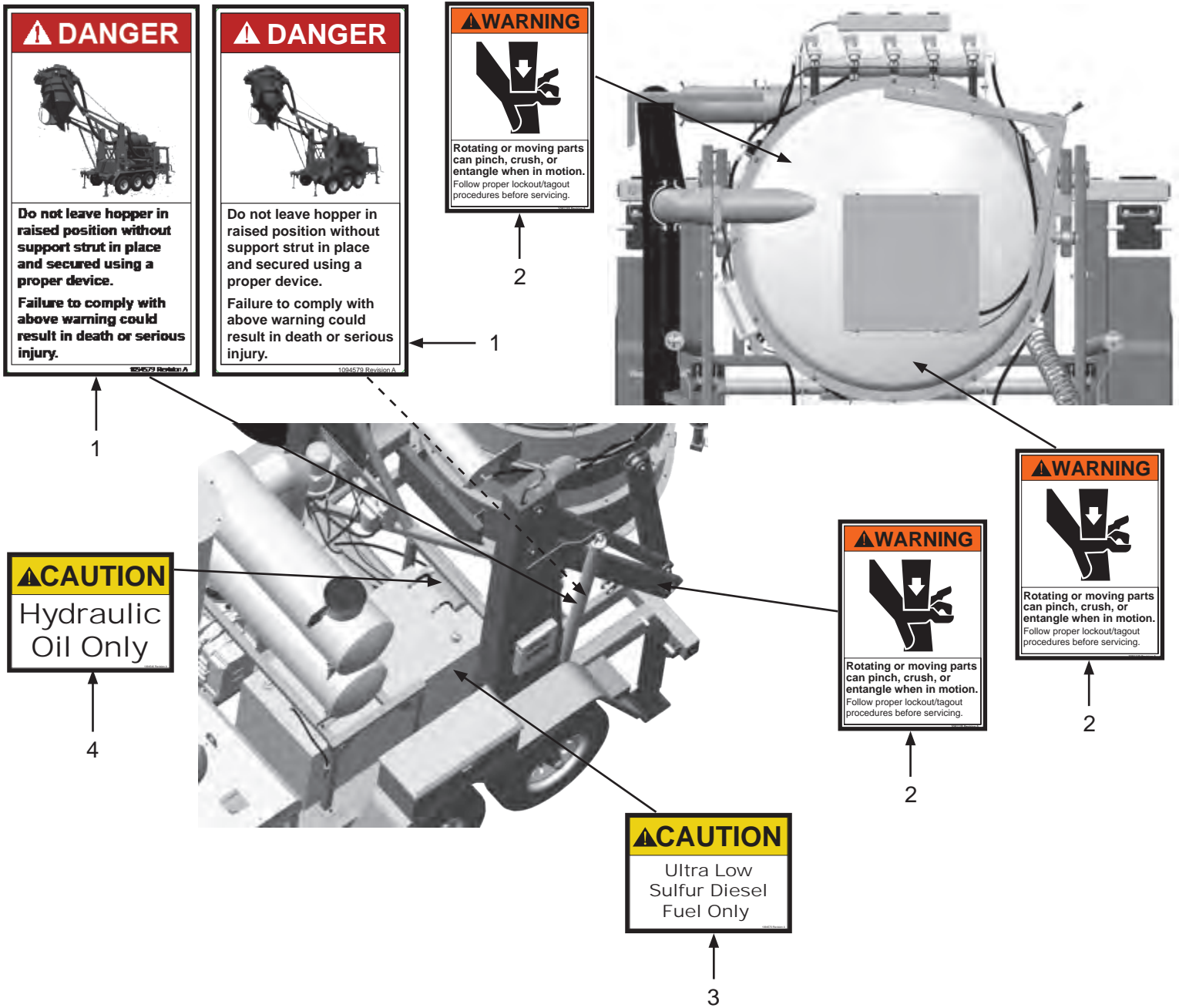

Item #	Part #	Description
1	1094579	Hopper Position Danger Decal
2	1091135	Rotating or Moving Parts Warning Decal
3	1094570	Ultra Low Sulfur Diesel Fuel Only Caution Decal
4	1094540	Hydraulic Oil Only Caution

# PART NUMBERS AND SCHEMATICS

Figure 24: Hazard Identification Decals (Cont.)

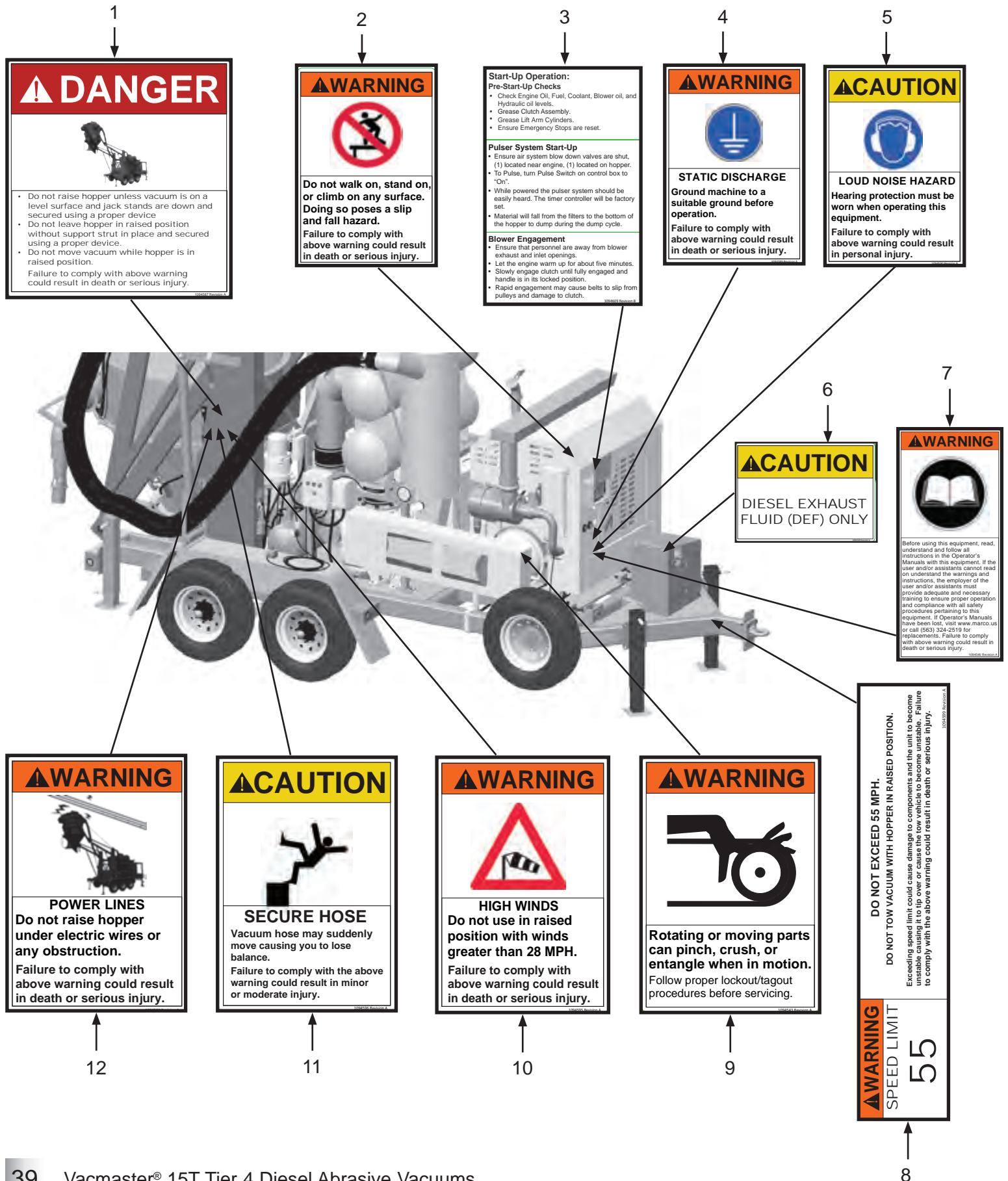



## PART NUMBERS AND SCHEMATICS

**Figure 24: Hazard Identification Decals (Cont.)**

<b>Item #</b>	<b>Part #</b>	<b>Description</b>
<b>Fig. 24</b>		
1	1094587	Do Not Raise Hopper Danger Decal
2	1094591	Do Not Climb On Warning Decal
3	1094609	Start-Up Operation Decal
4	1094589	Static Discharge Warning Decal
5	1094590	Loud Noise Hazard Warning Decal
6	1094569	Diesel Exhaust Fluid Only Warning Decal
7	1094546	Read Manual Warning Decal
8	1094599	Speed Limit Warning Decal
9	1094543	Rotating or Moving Parts Warning Decal
10	1094595	High Winds Warning Decal
11	1094596	Secure Hose Caution Decal
12	1094592	Power Line Warning Decal

# PART NUMBERS AND SCHEMATICS

Figure 25: Hazard Identification Decals (Cont.)



## PART NUMBERS AND SCHEMATICS

**Figure 25: Hazard Identification Decals (Cont.)**

<b>Item #</b>	<b>Part #</b>	<b>Description</b>
<b>Fig. 25</b>		
1	1094594	Do Not Open Door Warning Decal
2	1094581	No Not Vacuum Flammable Material Danger Decal
3	1094579	Hopper Position Danger Decal
4	1091135	Rotating or Moving Parts Warning Decal
5	1094580	Stay Clear Warning Decal
6	1094586	Powerful Suction Warning Decal
7	1091054	Confined Space Warning Decal

## OPTIONAL ACCESSORIES





**Part Numbers**

VACUUM HOSE							
Part Numbers	Vacuum Hose I.D.	Length	Vacuum HG	Cover Material	Reinforcement Material	Liner	Hose Color
10VH11250	1-1/2"	50 Ft.	29"	Pliovic®	Pliovic® PVC Helix	Polyurethane	Black
10VH225	2"	25 Ft.	29"	Pliovic®	Pliovic® PVC Helix	Polyurethane	Blue
10VH250	2"	50 Ft.	29"	Pliovic®	Pliovic® PVC Helix	Polyurethane	Blue
10VH200	2"	100 Ft.	29"	Pliovic®	Pliovic® PVC Helix	Polyurethane	Blue
10VH2550	2-1/2"	50 Ft.	29"	Pliovic®	Pliovic® PVC Helix	Polyurethane	Blue
10VH325	3"	25 Ft.	29"	Pliovic®	Pliovic® PVC Helix	Polyurethane	Blue
10VH350	3"	50 Ft.	29"	Pliovic®	Pliovic® PVC Helix	Polyurethane	Blue
10VH300	3"	100 Ft.	29"	Pliovic®	Pliovic® PVC Helix	Polyurethane	Blue
10VH425	4"	25 Ft.	29"	Pliovic®	Pliovic® PVC Helix	Polyurethane	Blue
10VH450	4"	50 Ft.	29"	Pliovic®	Pliovic® PVC Helix	Polyurethane	Blue
10VH400	4"	100 Ft.	29"	Pliovic®	Pliovic® PVC Helix	Polyurethane	Blue
10VH525	5"	25 Ft.	29"	Pliovic®	Pliovic® PVC Helix	Polyurethane	Blue
10VH550	5"	50 Ft.	29"	Pliovic®	Pliovic® PVC Helix	Polyurethane	Blue
10VH500	5"	100 Ft.	29"	Pliovic®	Pliovic® PVC Helix	Polyurethane	Blue
10VH625	6"	25 Ft.	25"	Pliovic®	Pliovic® PVC Helix	Polyurethane	Blue
10VH650	6"	50 Ft.	25"	Pliovic®	Pliovic® PVC Helix	Polyurethane	Blue
10VH600	6"	100 Ft.	25"	Pliovic®	Pliovic® PVC Helix	Polyurethane	Blue
10VH825	8"	25 Ft.	25"	Pliovic®	Pliovic® PVC Helix	Polyurethane	Blue
10VH850	8"	50 Ft.	25"	Pliovic®	Pliovic® PVC Helix	Polyurethane	Blue

## OPTIONAL ACCESSORIES

		VACUUM HOSE REDUCERS	
		Part Numbers	Size
	10106712	8" x 4"	
	10106716	6" x 4"	
	10106872	6" x 5"	

		WYE ADAPTERS	
		Part Numbers	Size
	10106719	4" x 2" x 2"	
	10107485	6" x 2" x 2"	
	10106723	6" x 4" x 4"	
	10106727	8" x 4" x 4"	

		VACUUM HOSE MENDERS			
		Vacuum Hose I.D.	Mender Length	Thickness	Material
	10HM2	2"	8"	1/8"	Steel
	10HM3	3"	9"	1/8"	Steel
	10HM4	4"	10"	1/8"	Steel
	10HM5	5"	11"	1/8"	Steel
	10HM6	6"	12"	1/8"	Steel
	10HM8	8"	14"	1/8"	Steel

## LITERATURE REFERENCES

### **Vacmaster® 15T Tier 4 Diesel Abrasive Vacuums**

106M148	Part Numbers & Schematics Guide – Vacmaster® 15T Tier 4 Diesel Abrasive Vacuums
1090148	Operator's Manual – Vacmaster® 15T Tier 4 Diesel Abrasive Vacuums
109V044	Operator's Manual - Perkins® Engine
109V521	Operator's Manual - Blower
109V582	Operator's Manual - Behnke Trailer



## CONTACT CENTER

- 3425 East Locust Street  
Davenport, IA 52803

ph: 800.BLAST.IT (800.252.7848)

ph: 563.324.2519

fax: 563.324.6258

## REGIONAL BRANCH OFFICES

- **Iowa**  
Davenport
- **Louisiana**  
Gonzales  
Lafayette
- **Ohio**  
Youngstown
- **Texas**  
Beaumont  
Corpus Christi  
Deer Park



ABRASIVES

BLASTING

COATING

DUST COLLECTION

RENTAL & SERVICE

SAFETY

VACUUMS

## 40+ NATIONWIDE SHIPPING LOCATIONS



★ Marco Regional Branch Offices  
and Shipping Locations

● Direct Shipping Locations

## CONTACT MARCO

**800.BLAST.IT**

**(800.252.7848)**

**563.324.2519**

**FAX: 563.324.6258**

**WWW.MARCO.US**

**SALES@MARCO.US**