



SPRAYMASTER® 60 GALLON HEATED COATING TANK



BUILT MARCO TOUGH
MARCO MANUFACTURED

PART NUMBERS AND SCHEMATICS GUIDE

Company Profile

Since 1944, Marco has developed a strong tradition of providing innovative and reliable products and services to the surface preparation and protective coatings industries. We are the world's premier provider of Abrasives, Blasting Equipment, Coating and Painting Equipment, Engineered Systems, Rental Equipment, Safety Equipment, Service, and Repair.

Through innovative designs and a total commitment to quality, Marco manufactures products that increase production rates, create a safer workplace, and reduce maintenance costs. Marco's industry experience, manufacturing capabilities, legendary customer service, product availability, logistics services, and technology leadership is your assurance that we deliver high quality products and services, providing the best value to you, our customer.

The Marco Difference

- **Industry Experience** – With Marco on your team, you have access to expertise which can only come from decades of industry leadership. We have organized our engineering department, production specialists, customer operations, and safety support into a “Center of Competence.” As a Marco customer, you have access to hundreds of years of cumulative experience related to your operations.
- **Manufacturing Excellence** – Marco is a U.S. based, ISO 9001:2008 certified manufacturer of equipment for the Surface Preparation and Protective Coatings industries. Marco's engineers benchmark the industry to ensure that we design and manufacture superior products that set the “Gold Standard” for performance, safety, and quality.
- **Legendary Customer Service** – Marco's legendary customer service team is staffed by friendly, highly-trained individuals who are focused on providing the highest level of product support, order accuracy, and customer satisfaction.
- **Product Availability** – We stock over 10,000 SKU's and have over 45 shipping locations to serve North American and International markets for all major brands of blasting and painting equipment. As the largest provider of surface preparation and protective coatings equipment in the world, our inventory levels and product availability are unmatched.
- **Logistics Services** – Marco's in-house logistics team is dedicated to moving your shipment anywhere in the world. We move over 14,000 truckloads every year, allowing you to save on freight costs by leveraging our buying power. Lower your process costs with a single invoice, which includes product and freight.
- **Technology Leadership** – Our website provides: Operator's Manuals, Part Numbers and Schematics Guides, MSDS information, and Features, Advantages, and Benefits Guides, providing access to information 24/7. Our Extranet application allows you to receive quotes and place orders online. Our Intranet maintains a complete record of your purchase history to assist with ongoing support of your existing equipment and future purchasing decisions.

Vision Statement

Marco is the world's premier provider of Abrasives, Blasting Equipment, Coating and Painting Equipment, Engineered Systems, Rental Equipment, Safety Equipment, Service, and Repair.

Mission Statement

Marco provides strong leadership and innovation to the surface preparation and protective coatings industries. We dedicate our efforts to the continuous improvement of our products, services, processes, people, and most importantly, the quality of our customer's experience.

Quality Policy

Marco is committed to providing superior quality in the design, manufacturing, distribution, rental, service, and repair of our products. Our ISO 9001:2008 certification extends throughout all operations in all locations. Continuous improvement of our processes and supply chain Integration comprise the core of our business strategy for delivering exceptional quality and value in all Marco products and services.

Management Philosophy

We are a company dedicated to the success of every customer and associate. We discuss, debate, challenge, measure, and test our ideas. We will be boundless and limitless in our passion to improve. Through sound leadership and dedicated associates, we will ensure a long term, profitable future for Marco, our associates, customers, and suppliers.

TABLE OF CONTENTS

Company Profile	1
Table of Contents	2
Spraymaster® 60 Gallon Heated Coating Tank Part Numbers and Schematics	3-9
Part Numbers	3-4
Spraymaster® 60 Gallon Heated Coating Tank 240/480-Volt AC Hazardous Location	5-6
Spraymaster® 60 Gallon Heated Coating Tank 240/480-Volt AC Hazardous Location with 5:1 Transfer Pump	7
Spraymaster® 60 Gallon Heated Coating Tank 240/480-Volt AC Hazardous Location with 10:1 Transfer Pump	8
Wye Strainer	9
Maintenance Notes	10

PART NUMBERS AND SCHEMATICS GUIDE

SPRAYMASTER® 60 GALLON HEATED COATING TANKS						
Part Numbers	Immersion Heater Power	5:1 Transfer Pump	10:1 Transfer Pump	ELECTRICAL	Agitator	AIR MOTOR
				Hazardous Location		15:1 Gear Driven
20101225	240-Volt AC	X		X	X	X
20101227	240-Volt AC		X	X	X	X
20101262	240-Volt AC			X	X	X
20101226	480-Volt AC	X		X	X	X
20101228	480-Volt AC		X	X	X	X
20101263	480-Volt AC			X	X	X

PART NUMBERS AND SCHEMATICS GUIDE



20101225
20101226



20101227
20101228



20101262
20101263

PART NUMBERS AND SCHEMATICS GUIDE

Spraymaster® 60 Gallon Heated Coating Tank 240/480-Volt AC Hazardous Location

Item#	Part#	Description
Fig. 1		
—	20101262	Spraymaster® 60 Gallon Heated Coating Tank 240-Volt AC Hazardous Location – Complete
—	20101263	Spraymaster® 60 Gallon Heated Coating Tank 480-Volt AC Hazardous Location – Complete
1	20100827	15:1 Gear Driven Air Motor <i>(Includes Item #2)</i>
2	20BK350401	Air Motor Muffler Assembly
3	10103292	1/4" NPT Needle Valve
4	20PFHA24SA0402	1/8" x 1/4" NPT Hex Nipple
5	20100843	1" x 1" Shaft Coupling
6	20101104	Mixer Blade
7	1011901	1" NPT Square Head Plug <i>(Five Required)</i>
8	20PFHA25UA0404	1/4" NPT (M) 90° Elbow
9	20101050	60 Gallon Round HVL Lid Weldment
10	20100131	1/4-14 x 1-1/2" Self-Tapping Screw <i>(Four Required)</i>
11	20100494	240V/480V Hazardous Location Immersion Heater
12	20HHH0254F47	1/4" NPT 0-250 Thermometer
13	20100531	Heated Supply Tank
14	20100186	1" NPT Square Head Plug with 1/8" Relief Hole
15	20100173	Hot Surfaces Warning Label
16	2090116	Heater Notice Label
17	10101339	2" NPT 90° Elbow
18	20100146	2" x 6" NPT Nipple
19	1011604	2" Full Port Ball Valve
20	20100897	5/16-18 x 1-1/2" Hex Bolt <i>(Four Required)</i>
21	10L805003	5/16" Flat Washer <i>(Eight Required)</i>
22	20100900	5/16-18 Hex Lock Nut <i>(Four Required)</i>
—	1091130	Hazard Identification Decal
—	2090117	Hazard Identification Decal
—	205M115	Features & Specifications Guide – Spraymaster® Heated Coating Tank
—	206M115	Part Numbers & Schematics Guide – Spraymaster® Heated Coating Tank
—	2090115	Operator's Manual – Spraymaster® Heated Coating Tank
—	209V515	Operator's Manual – AM Series Lubricated Air Motors

PART NUMBERS AND SCHEMATICS GUIDE

Figure 1: Spraymaster® 60 Gallon Heated Coating Tank 240/480-Volt AC Hazardous Location

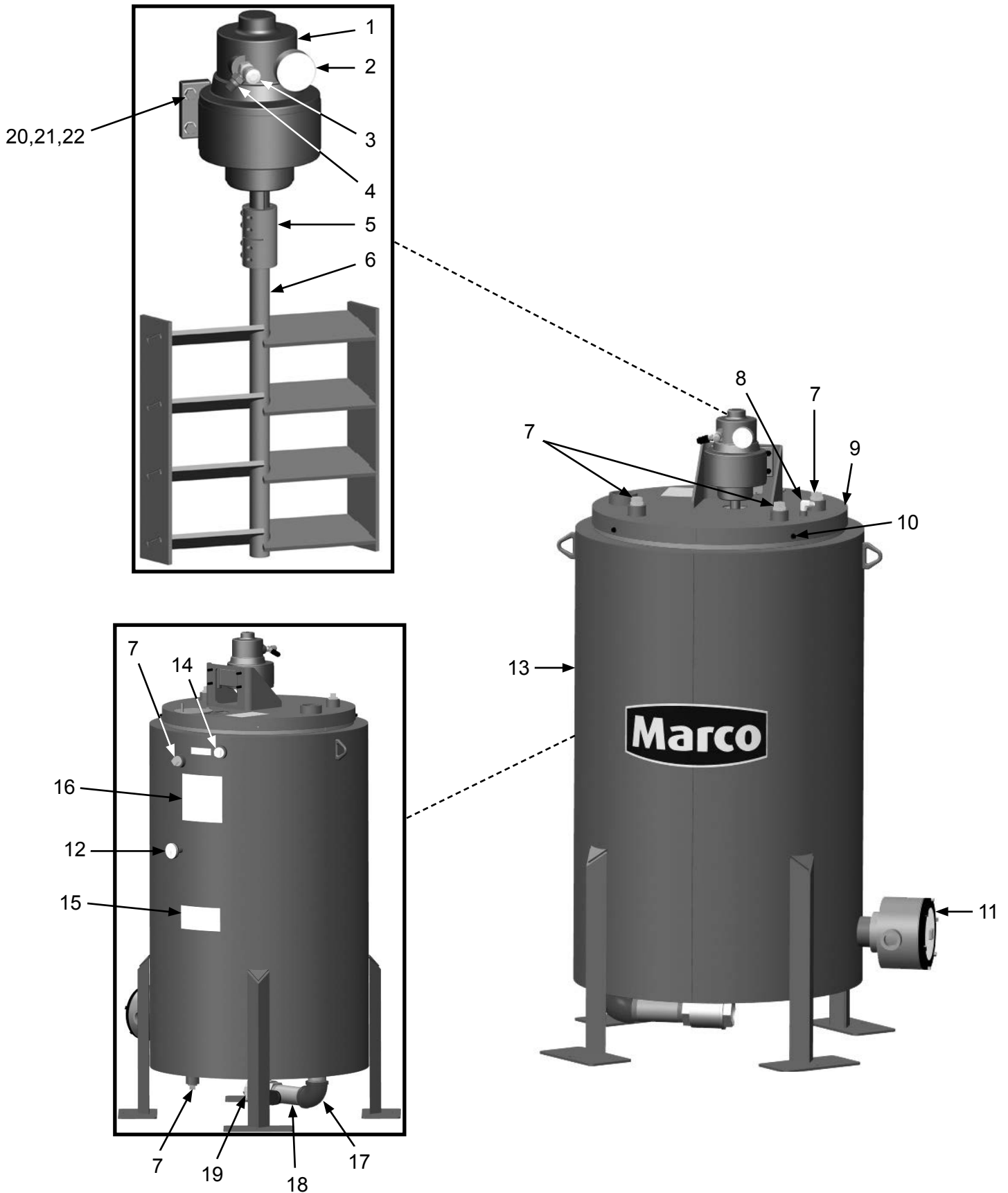

PART NUMBERS AND SCHEMATICS GUIDE

Figure 2: Spraymaster® 60 Gallon Heated Coating Tank 240/480-Volt AC Hazardous Location with 5:1 Transfer Pump

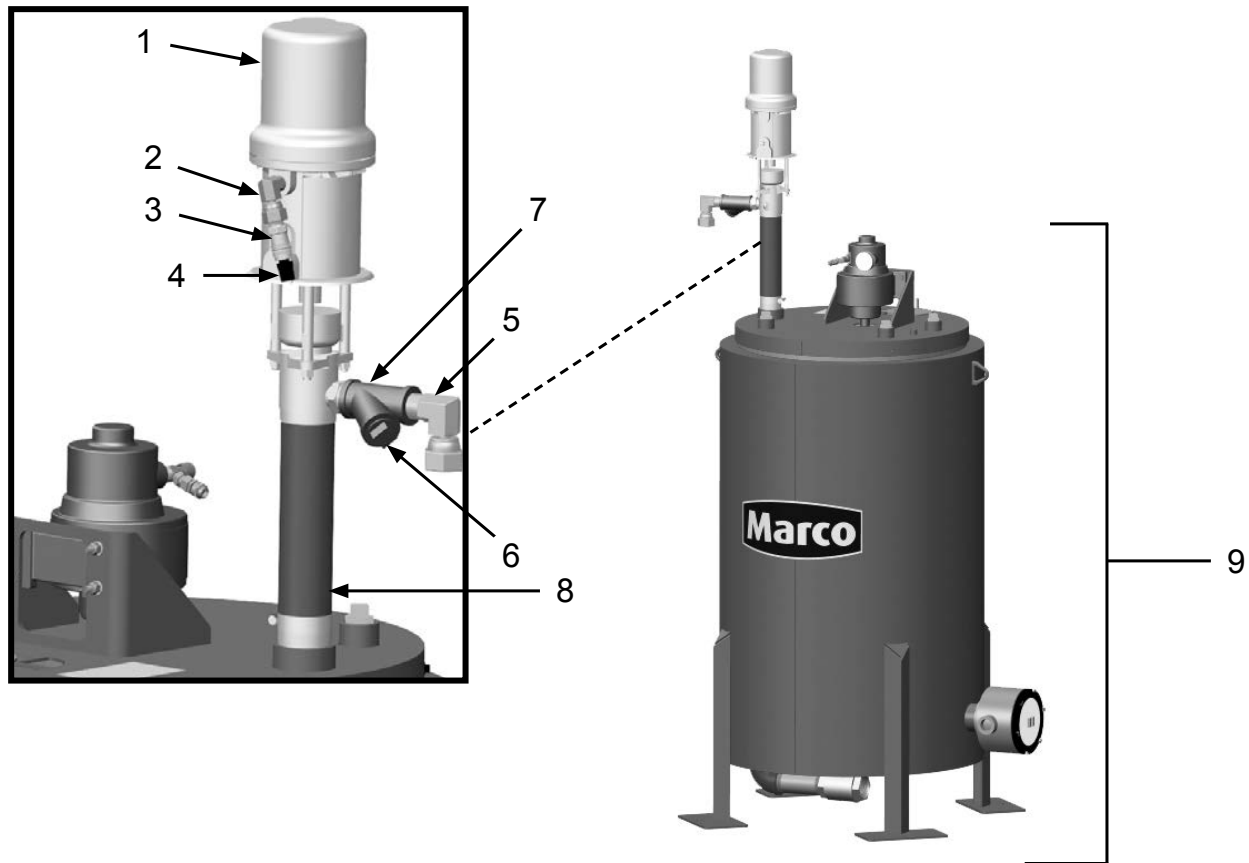

Item#	Part#	Description
Fig. 2		
—	20101225	Spraymaster® 60 Gallon Heated Coating Tank 240-Volt AC Hazardous Location with 5:1 Transfer Pump – Complete
—	20101226	Spraymaster® 60 Gallon Heated Coating Tank 480-Volt AC Hazardous Location with 5:1 Transfer Pump – Complete
1	20G248825	Monark® 5:1 Feed Pump
2	20PFHA60UA0606	3/8" NPT (M) x 3/8" (F) 90° Swivel Elbow
3	20100285	3/8" NPT 1/4" Male Quick Disconnect
4	20100286	3/8" NPT 1/4" Female Quick Disconnect
5	20PFHA60UA1616	1" NPT (M) x 1" (F) 90° Swivel Elbow
6	20PFHA24SA1612	1" x 3/4" NPT Hex Nipple
7	20000060	1" Wye Strainer
8	20101105	8-1/2" Tank Pump Spacer
9	20100531	Spraymaster® 60 Gallon Heated Coating Tank 240-Volt AC Hazardous Location
—	205M115	Features & Specifications Guide – Spraymaster® Heated Coating Tank
—	206M115	Part Numbers & Schematics Guide – Spraymaster® Heated Coating Tank
—	2090115	Operator's Manual – Spraymaster® Heated Coating Tank
—	209V510	Operator's Manual – Merkur® Displacement Pump
—	209V511	Operator's Manual – Graco® Feed and Solvent Flush Kits
—	209V513	Operator's Manual – 5:1 Ratio Monark® Pump
—	209V515	Operator's Manual – AM Series Lubricated Air Motors

PART NUMBERS AND SCHEMATICS GUIDE

Figure 3: Spraymaster® 60 Gallon Heated Coating Tank 240/480-Volt AC Hazardous Location with 10:1 Transfer Pump

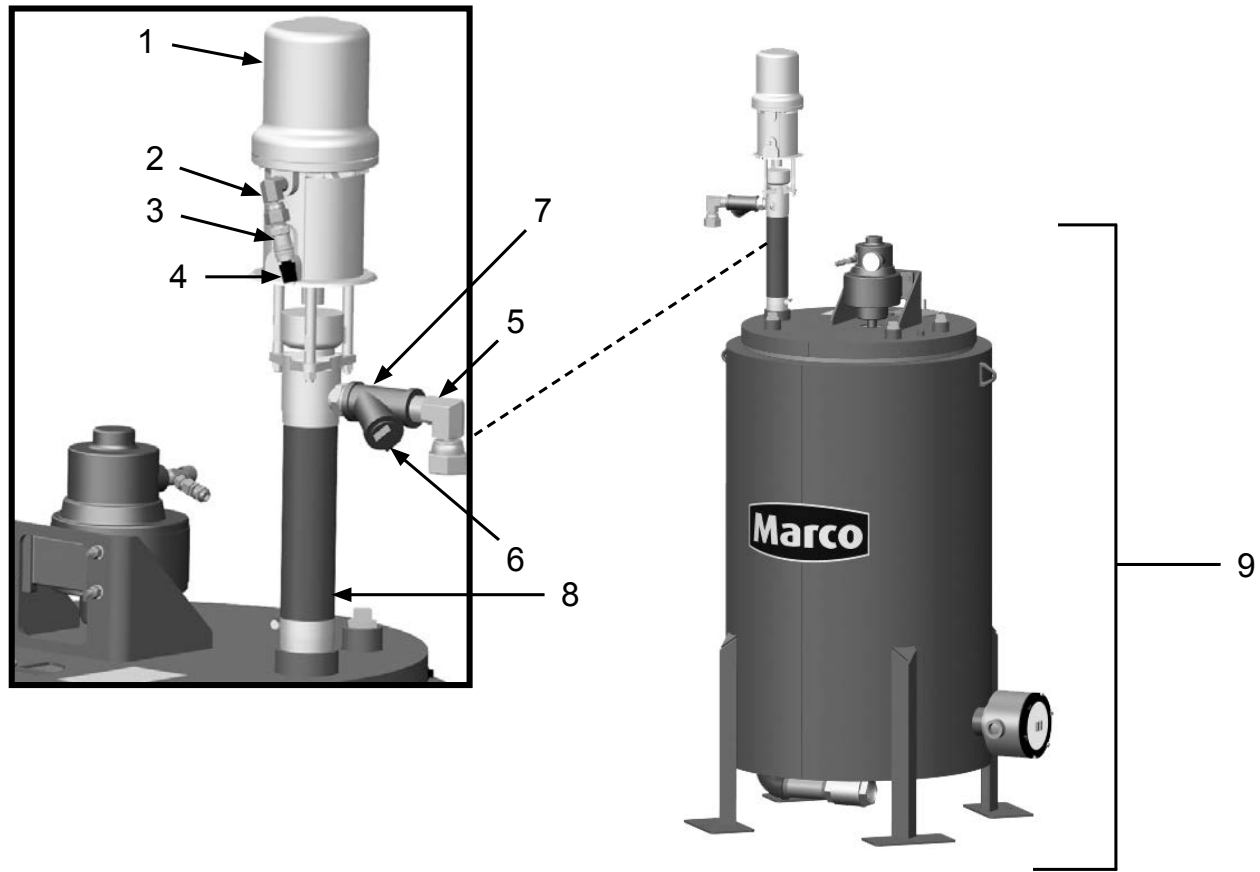

Item#	Part#	Description
Fig. 3		
—	20101227	Spraymaster® 60 Gallon Heated Coating Tank 240-Volt AC Hazardous Location with 10:1 Transfer Pump – Complete
—	20101228	Spraymaster® 60 Gallon Heated Coating Tank 480-Volt AC Hazardous Location with 10:1 Transfer Pump – Complete
1	20G256433	President® 10:1 Feed Pump
2	20PFHA60UA0606	3/8" NPT (M) x 3/8" (F) 90° Swivel Elbow
3	20100285	3/8" NPT 1/4" Male Quick Disconnect
4	20100286	3/8" NPT 1/4" Female Quick Disconnect
5	20PFHA60UA1616	1" NPT (M) x 1" (F) 90° Swivel Elbow
6	20PFHA24SA1612	1" x 3/4" NPT Hex Nipple
7	20000060	1" Wye Strainer
8	20101105	8-1/2" Tank Pump Spacer
9	20100531	Spraymaster® 60 Gallon Heated Coating Tank 240-Volt AC Hazardous Location
—	205M115	Features & Specifications Guide – Spraymaster® Heated Coating Tank
—	206M115	Part Numbers & Schematics Guide – Spraymaster® Heated Coating Tank
—	2090115	Operator's Manual – Spraymaster® Heated Coating Tank
—	209V510	Operator's Manual – Merkur® Displacement Pump
—	209V511	Operator's Manual – Graco® Feed and Solvent Flush Kits
—	209V514	Operator's Manual – 10:1 Ratio President® Pump
—	209V515	Operator's Manual – AM Series Lubricated Air Motors

PART NUMBERS AND SCHEMATICS GUIDE

Figure 4: Wye Strainer

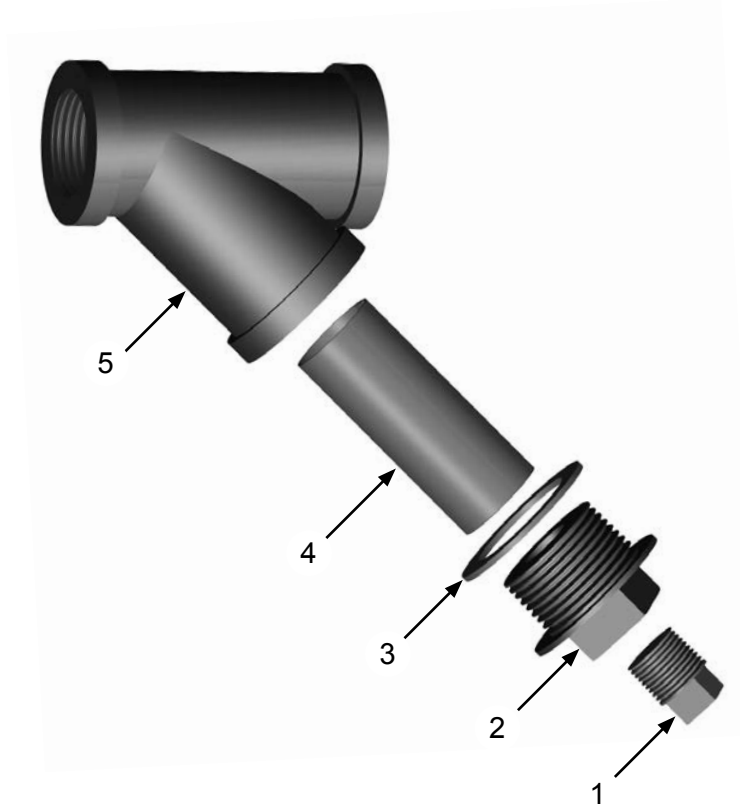

Item#	Part#	Description
Fig. 4		
1	20PFHA24ST06	3/8" Pipe Plug
2	1011901	1" NPT Pipe Plug
3	20100666	Y-Strainer Gasket 1-3/4" O.D. x 1-1/4" I.D.
4	20100470	Strainer Screen
5	20000060	1" Wye Strainer

GLOBAL HEADQUARTERS

- 3425 East Locust Street
Davenport, IA 52803

ph: 800.BLAST.IT (800.252.7848)

ph: 563.324.2519

fax: 563.324.6258

GULF STATES HEADQUARTERS

- 701 East Boulevard
Deer Park, TX 77536

ph: 800.BLAST.IT (800.252.7848)

ph: 281.930.0905

fax: 281.542.0736

REGIONAL BRANCH OFFICES

- **Iowa**
Davenport
- **Louisiana**
Gonzales
Harvey
Lafayette
- **Ohio**
Youngstown
- **Texas**
Beaumont
Corpus Christi
Deer Park



ABRASIVES

BLASTING

COATING

DUST COLLECTORS

ENGINEERED SYSTEMS

RENTAL

SAFETY

SERVICE & REPAIR

VACUUMS

40+ NATIONWIDE SHIPPING LOCATIONS

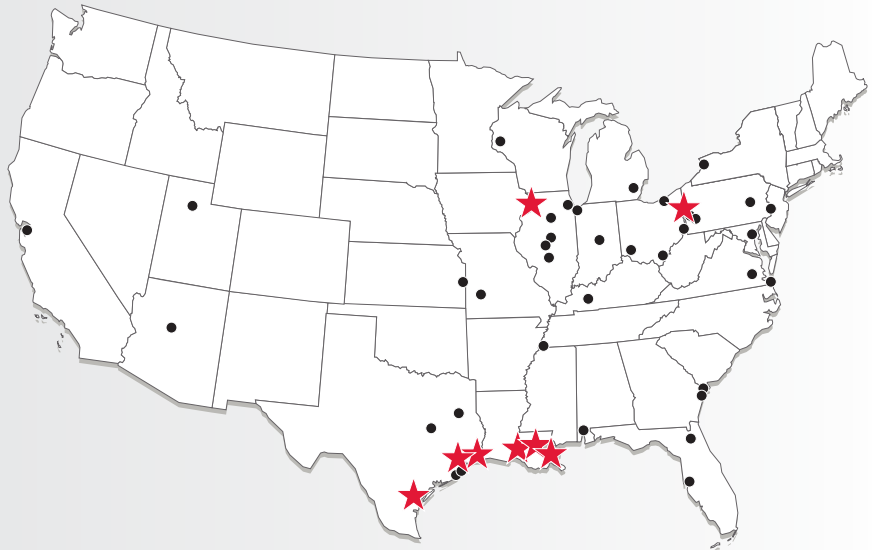

★ Marco Regional Branch Offices
and Shipping Locations

● Direct Shipping Locations

CONTACT MARCO

800.BLAST.IT
(800.252.7848)

563.324.2519

FAX: 563.324.6258

WWW.MARCO.US

SALES@MARCO.US