



**PAULI SYSTEMS
AUTOLOK FEATHERTOUCH™
REMOTE CONTROL SWITCH**



BUILT MARCO TOUGH
MARCO MANUFACTURED

PART NUMBERS AND SCHEMATICS GUIDE

Company Profile

Since 1944, Marco has developed a strong tradition of providing innovative and reliable products and services to the surface preparation and protective coatings industries. We are the world's premier provider of Abrasives, Blasting Equipment, Coating Equipment, Engineered Systems, Rental Equipment, Safety Equipment, Service, and Repair.

Through innovative designs and a total commitment to quality, Marco manufactures products that increase production rates, create a safer workplace, and reduce maintenance costs. Marco's industry experience, manufacturing capabilities, legendary customer service, product availability, logistics services, and technology leadership is your assurance that we deliver high quality products and services, providing the best value to you, our customer.

The Marco Difference

- **Industry Experience** – With Marco on your team, you have access to expertise which can only come from decades of industry leadership. We have organized our engineering department, production specialists, customer operations, and safety support into a "Center of Competence." As a Marco customer, you have access to hundreds of years of cumulative experience related to your operations.
- **Manufacturing Excellence** – Marco is a U.S. based, ISO 9001:2008 certified manufacturer of equipment for the Surface Preparation and Protective Coatings industries. Marco's engineers benchmark the industry to ensure that we design and manufacture superior products that set the "Gold Standard" for performance, safety, and quality.
- **Legendary Customer Service** – Marco's legendary customer service team is staffed by friendly, highly-trained individuals who are focused on providing the highest level of product support, order accuracy, and customer satisfaction.
- **Product Availability** – We stock over 10,000 SKU's and have over 45 shipping locations to serve North American and International markets for all major brands of blasting and painting equipment. As the largest provider of surface preparation and protective coatings equipment in the world, our inventory levels and product availability are unmatched.
- **Logistics Services** – Marco's in-house logistics team is dedicated to moving your shipment anywhere in the world. We move over 14,000 truckloads every year, allowing you to save on freight costs by leveraging our buying power. Lower your process costs with a single invoice, which includes product and freight.
- **Technology Leadership** – Our website provides: Operator's Manuals, Part Numbers and Schematics Guides, MSDS information, and Features and Specifications Guides, providing access to information 24/7. Our Extranet application allows you to receive quotes and place orders online. Our Intranet maintains a complete record of your purchase history to assist with ongoing support of your existing equipment and future purchasing decisions.

Vision Statement

Marco is the world's premier provider of Abrasives, Blasting Equipment, Coating Equipment, Engineered Systems, Rental Equipment, Safety Equipment, Service, and Repair.

Mission Statement

Marco provides strong leadership and innovation to the surface preparation and protective coatings industries. We dedicate our efforts to the continuous improvement of our products, services, processes, people, and most importantly, the quality of our customer's experience.

Quality Statement

Marco is committed to providing superior quality in the design, manufacturing, distribution, rental, service, and repair of our products. Our ISO 9001:2008 certification extends throughout all operations in all locations. Continuous improvement of our processes and supply chain Integration comprise the core of our business strategy for delivering exceptional quality and value in all Marco products and services.

Management Philosophy

We are a company dedicated to the success of every customer and associate. We discuss, debate, challenge, measure, and test our ideas. We will be boundless and limitless in our passion to improve. Through sound leadership and dedicated associates, we will ensure a long term, profitable future for Marco, our associates, customers, and suppliers.

TABLE OF CONTENTS

Company Profile	1
Table of Contents	2
Pauli Systems Autolok Feathertouch™	
Remote Control Switch	3-8
Part Number	3-4
Part Numbers & Schematics	5-6
Optional Accessories	7-8
Maintenance Notes	9-10

PART NUMBER

PAULI SYSTEMS AUTOLOK FEATHERTOUCH™ REMOTE CONTROL SWITCH

Part Numbers	Body Material	Repairable	Pneumatic Control Line Fittings
10PG62010018	Aluminum	Yes	1/4" & 1/8" NPT

PAULI SYSTEMS AUTOLOK FEATHERTOUCH™ REMOTE CONTROL SWITCH



PART NUMBERS & SCHEMATICS

Pauli Systems AutoLok Feathertouch™ Remote Control Switch

Item #	Part #	Description
Fig. 1		
—	10PG62010018	Pauli Systems AutoLok Feathertouch™ Remote Control Switch – Complete
1	10PG22610103	10-24 Acorn Nut
2	10PG22606018	1/4" x 3/4" Shoulder Screw
3	10PG27606024	Handle
4	10PG47003005	O-Ring (<i>Two Required</i>)
5	10PG62015084	Control Valve Stem
6	10PG62015216	Stem Button (<i>Two Required</i>)
7	10PG62015211	Control Valve Spool
8	10PG22612509	Retaining Ring
9	10PG54503003	Safety Spring
10	10PG49003012	Safety Lock Pin
11	10102187	1/8" NPS x 1/8" NPT Adapter
12	10102186	1/4" NPS x 1/8" NPT Adapter
13	10PG22606802	10-32 x 3/8" Screw (<i>Two Required</i>)
14	10PG23025039	Clamp (<i>Two Required</i>)
15	10PG62015004	Body
16	10PG54503102	Handle Spring
17	10PG62010026	Control Valve Assembly (<i>Includes Item #'s: 4–7</i>)
18	10PG22607822	8-32 x 3/8" Stainless Steel Screw
—	10PG36003006	Autolok Feathertouch™ Remote Control Switch Service Kit (<i>Includes Item #'s: 1, 8, 9, 11, 12, 13, 18, and 17</i>)
—	106M320	Part Numbers and Schematics Guide – Pauli Systems Autolok Feathertouch™ Remote Control Switch



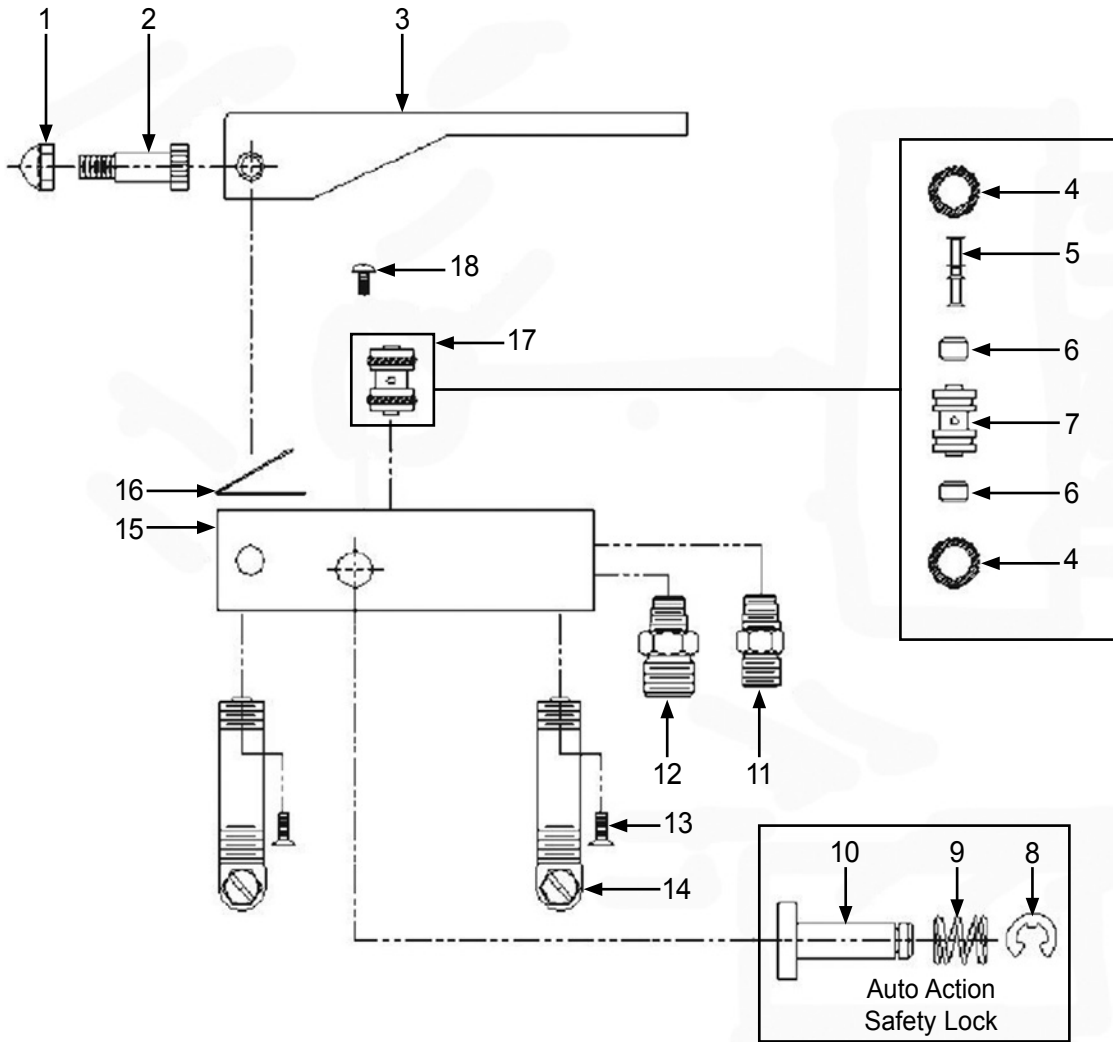

PART NUMBERS & SCHEMATICS

Figure 2: Pauli Systems AutoLok Feathertouch™ Remote Control Switch











OPTIONAL ACCESSORIES

PNEUMATIC CONTROL LINE

	Part Numbers	Hose Length	Working Pressure	Hose I.D.	Hose O.D.	1017012 Quantity of Two	1017013 Quantity of Two
	10TL10PG	10 Feet	200 psi	3/16"	7/16"	X	X
	10TL50PG	50 Feet	200 psi	3/16"	7/16"	X	X
	10TL100PG	100 Feet	200 psi	3/16"	7/16"	X	X
	10TLBK	Per Foot	200 psi	3/16"	7/16"		

OPTIONAL ACCESSORIES

		PNEUMATIC CONTROL LINE FITTINGS		
	Part Numbers	Description	Hose I.D.	Hose O.D.
	1017012	1/8" Female Nut & Barb	3/16"	7/16"
	1017013	1/4" Female Nut & Barb	3/16"	7/16"
	1017010	Hose Splicer	3/16"	7/16"
	1017017	Hose Ferrule	3/16"	7/16"
	1017011	Oetiker® Clamp	3/16"	7/16"
	1017026	1/8" x 1/8" Hose Union	3/16"	7/16"
	1017027	1/4" x 1/4" Hose Union	3/16"	7/16"

	Part Numbers	PNEUMATIC CONTROL LINE FITTINGS ACCESSORIES	
	10DX855A	Ferrule Crimping Tool	
	10DX1098	Oetiker® Clamp Tool	

Oetiker® is a registered trademark of Dixon Valve & Coupling Co.

GLOBAL HEADQUARTERS

- 3425 East Locust Street
Davenport, IA 52803

ph: 800.BLAST.IT (800.252.7848)

ph: 563.324.2519

fax: 563.324.6258

GULF STATES HEADQUARTERS

- 701 East Boulevard
Deer Park, TX 77536

ph: 800.BLAST.IT (800.252.7848)

ph: 281.930.0905

fax: 281.542.0736

REGIONAL BRANCH OFFICES

- **Iowa**
Davenport
- **Louisiana**
Gonzales
Lafayette
- **Ohio**
Youngstown
- **Texas**
Beaumont
Corpus Christi
Deer Park



ABRASIVES

BLASTING

COATING

DUST COLLECTORS

ENGINEERED SYSTEMS

RENTAL

SAFETY

SERVICE & REPAIR

VACUUMS

40+ NATIONWIDE SHIPPING LOCATIONS



★ Marco Regional Branch Offices
and Shipping Locations

● Direct Shipping Locations

CONTACT MARCO

800.BLAST.IT

(800.252.7848)

563.324.2519

FAX: 563.324.6258

WWW.MARCO.US

SALES@MARCO.US