

Xtreme® XL Packages

334645B
EN

High performance, high pressure spray packages for applying protective coatings. For professional use only.



Important Safety Instructions

Read all warnings and instructions in this manual and in related manuals. Save these instructions.

See Models on page 6 for maximum working pressures.

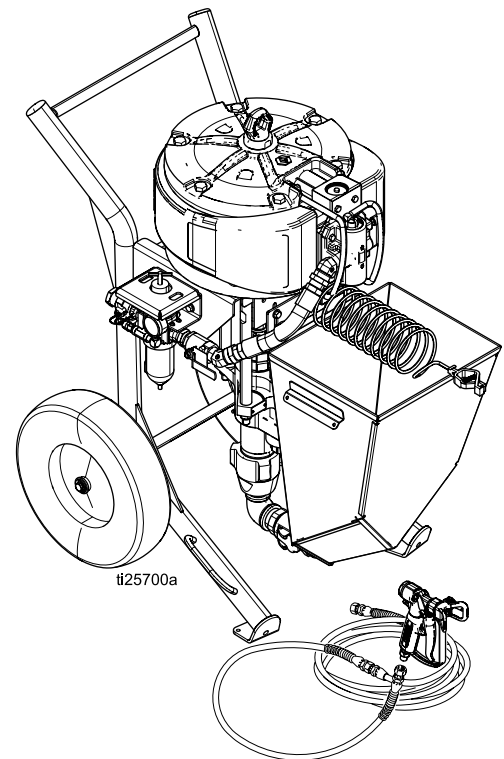

Contents





Related Manuals	3	Spray.....	19
Warnings	4	Shutdown.....	19
Sprayer Packages	7	Maintenance	20
Heavy Fluids Sprayer Packages	8	Preventative Maintenance Schedule	20
Pump Packages	8	Daily Maintenance	20
Component Identification - Cart Mount	9	Corrosion Protection	20
Component Identification - Wall Mount	10	Cart Maintenance.....	20
System Components.....	11	Troubleshooting.....	21
Grounding	11	Remove Lower.....	22
Install Wall Mount Assembly.....	12	Disconnect and Reconnect Lower.....	22
Install Hopper Assembly.....	12	Parts.....	23
Setup.....	13	Dimensions	34
Pressure Relief Procedure	14	Performance Charts.....	36
Flush	15	Technical Specifications.....	39
Prime.....	17	Graco Standard Warranty.....	40









Related Manuals

Manual	Description
334644	Xtreme XL Air Motor, Instructions-Parts
3A0293	Air Controls, Instructions-Parts
311825	Dura-Flo™ Lowers, Instructions-parts
311762	Xtreme® Lowers, Instructions-Parts
311164	NXT® Xtreme Packages, Instructions-Parts





Warnings

The following warnings are for the setup, use, grounding, maintenance, and repair of this equipment. The exclamation point symbol alerts you to a general warning and the hazard symbols refer to procedure-specific risks. When these symbols appear in the body of this manual or on warning labels, refer back to these Warnings. Product-specific hazard symbols and warnings not covered in this section may appear throughout the body of this manual where applicable.

 WARNING	
   	<p>FIRE AND EXPLOSION HAZARD</p> <p>Flammable fumes, such as solvent and paint fumes, in work area can ignite or explode. Paint or solvent flowing through the equipment can cause static sparking. To help prevent fire and explosion:</p> <ul style="list-style-type: none">• Use equipment only in well ventilated area.• Eliminate all ignition sources; such as pilot lights, cigarettes, portable electric lamps, and plastic drop cloths (potential static sparking).• Ground all equipment in the work area. See Grounding instructions.• Never spray or flush solvent at high pressure.• Keep work area free of debris, including solvent, rags and gasoline.• Do not plug or unplug power cords, or turn power or light switches on or off when flammable fumes are present.• Use only grounded hoses.• Hold gun firmly to side of grounded pail when triggering into pail. Do not use pail liners unless they are anti-static or conductive.• Stop operation immediately if static sparking occurs or you feel a shock. Do not use equipment until you identify and correct the problem.• Keep a working fire extinguisher in the work area.

 WARNING	
    	<p>SKIN INJECTION HAZARD</p> <p>High-pressure fluid from gun, hose leaks, or ruptured components will pierce skin. This may look like just a cut, but it is a serious injury that can result in amputation. Get immediate surgical treatment.</p> <ul style="list-style-type: none"> • Do not spray without tip guard and trigger guard installed. • Engage trigger lock when not spraying. • Do not point gun at anyone or at any part of the body. • Do not put your hand over the spray tip. • Do not stop or deflect leaks with your hand, body, glove, or rag. • Follow the Pressure Relief Procedure when you stop spraying and before cleaning, checking, or servicing equipment. • Tighten all fluid connections before operating the equipment. • Check hoses and couplings daily. Replace worn or damaged parts immediately.
 	<p>EQUIPMENT MISUSE HAZARD</p> <p>Misuse can cause death or serious injury.</p> <ul style="list-style-type: none"> • Do not operate the unit when fatigued or under the influence of drugs or alcohol. • Do not exceed the maximum working pressure or temperature rating of the lowest rated system component. See Technical Data in all equipment manuals. • Use fluids and solvents that are compatible with equipment wetted parts. See Technical Data in all equipment manuals. Read fluid and solvent manufacturer's warnings. For complete information about your material, request MSDS from distributor or retailer. • Do not leave the work area while equipment is energized or under pressure. • Turn off all equipment and follow the Pressure Relief Procedure when equipment is not in use. • Check equipment daily. Repair or replace worn or damaged parts immediately with genuine manufacturer's replacement parts only. • Do not alter or modify equipment. Alterations or modifications may void agency approvals and create safety hazards. • Make sure all equipment is rated and approved for the environment in which you are using it. • Use equipment only for its intended purpose. Call your distributor for information. • Route hoses and cables away from traffic areas, sharp edges, moving parts, and hot surfaces. • Do not kink or over bend hoses or use hoses to pull equipment. • Keep children and animals away from work area. • Comply with all applicable safety regulations.

WARNING

 	<p>MOVING PARTS HAZARD</p> <p>Moving parts can pinch, cut or amputate fingers and other body parts.</p> <ul style="list-style-type: none">• Keep clear of moving parts.• Do not operate equipment with protective guards or covers removed.• Pressurized equipment can start without warning. Before checking, moving, or servicing equipment, follow the Pressure Relief Procedure and disconnect all power sources.
	<p>TOXIC FLUID OR FUMES HAZARD</p> <p>Toxic fluids or fumes can cause serious injury or death if splashed in the eyes or on skin, inhaled, or swallowed.</p> <ul style="list-style-type: none">• Read MSDSs to know the specific hazards of the fluids you are using.• Store hazardous fluid in approved containers, and dispose of it according to applicable guidelines.
	<p>PERSONAL PROTECTIVE EQUIPMENT</p> <p>Wear appropriate protective equipment when in the work area to help prevent serious injury, including eye injury, hearing loss, inhalation of toxic fumes, and burns. Protective equipment includes but is not limited to:</p> <ul style="list-style-type: none">• Protective eyewear, and hearing protection.• Respirators, protective clothing, and gloves as recommended by the fluid and solvent manufacturer.

Sprayer Packages

Check your sprayer or wall mount package's identification plate (ID) on the side of the shelf mounting bracket for the 6 digit part number of your package. Use the following matrix to define the construction of your package, based on the six digits. For example, Sprayer Part Number XL 45 H 3 represents the Xtreme XL brand (XL), pressure ratio (45 :1), on a heavy duty cart (H), and complete package (gun, hose, and pump filter included) (3). To order replacement parts, see [Parts, page 23](#).

The diagram shows a rectangular identification plate with the following fields:

- PART NO.**: A 6-digit field with an arrow pointing to it from the left.
- SERIAL NO.**: A field for the serial number.
- SERIES**: A field for the series.
- MAX AIR WPR**: A field for maximum air working pressure, with sub-fields for MPa, bar, and PSI.
- MAX FLUID WPR**: A field for maximum fluid working pressure, with sub-fields for MPa, bar, and PSI.
- MAX TEMP**: A field for maximum temperature, with sub-fields for °C and °F.
- WEIGHT**: A field for weight, with sub-fields for kg and lb.
- MADE IN**: A field for the country of origin.
- GRACO** logo and company information: GRACO INC., P.O. Box 1441, Minneapolis, MN 55440 U.S.A.
- BARCODE** area.
- CE** and **Ex II 2 G** certification marks.
- EAC** certification mark.
- Artwork No. 292493 Rev. E**

ti25703b

Note

All packages include 1 in. air controls consisting of inlet claw fittings, 40 micron filter/regulator, relieving ball valve, and motor hose.

Approvals:



Maximum Air Working Pressure:

Never exceed the maximum air WPR listed on your model ID plate. This is the maximum set point on regulator (G) which is read on gauge (E).

Pressure Ratio	Maximum Air WPR	Maximum Fluid WPR
XL 45	95 psi (0.65 MPa, 6.5 bar)	4500 psi (31 MPa, 310 bar)
XL 70	100 psi (0.7 MPa, 7 bar)	7100 psi (48 MPa, 489 bar)
XL 80	88 psi (0.6 MPa, 6 bar)	7250 psi (50 MPa, 500 bar)
XL 95	76 psi (0.5 MPa, 5 bar)	7250 psi (50 MPa, 500 bar)

XL	45	H		3		
First and Second Digit	Third and Fourth Digit	Fifth Digit		Sixth Digit		
	Pressure Ratio (xx:1)	Mount Option		With Hose and Gun	Hopper	Filter
XL	45*	H	Heavy Duty Cart	1		✓
	70	W	Wall Mount	2	✓	✓
	80			3	✓	✓
	95			4	NA	NA

* Uses a Dura-Flo lower.

Heavy Fluids Sprayer Packages

Packages include a hopper, no fluid filter, 3/4 in outlet check valve, 3/4 in x 50 ft. (15 m) hose, 1/2 in x 25 ft (7.6 m) whip and XHF spray gun with 429 tip

24X593 - 70:1

24X594 - 80:1

Pump Packages

Check your pump package's identification plate (ID), attached to the black motor shroud, for the 6-digit part number of your pump package. For example, Pump Part Number PL 45 C 2 represents the pump (PL), pressure ratio (45:1), carbon steel construction (C), and no built-in filter or air controls (2).

To order replacement parts, see [Pump Package Parts](#).

Note

Heavy-fluid materials vary and should be tested with a qualified distributor. Material should be pourable and self-leveling.

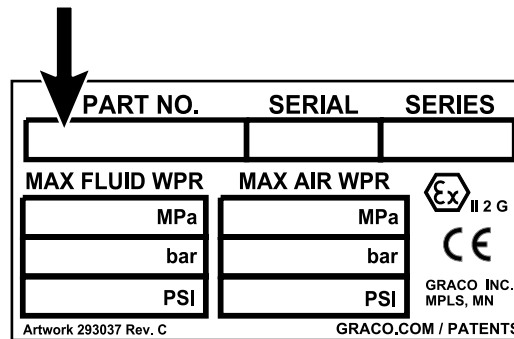

ti25704a

Pressure Ratio	Maximum Air WPR	Maximum Fluid WPR
PL 45	95 psi (0.65 MPa, 6.5 bar)	4500 psi (31 MPa, 310 bar)
PL 70	100 psi (0.7 MPa, 7 bar)	7100 psi (48 MPa, 489 bar)
PL 80	88 psi (0.6 MPa, 6 bar)	7250 psi (50 MPa, 500 bar)
PL 95	76 psi (0.5 MPa, 5 bar)	7250 psi (50 MPa, 500 bar)

PL	45	C	2
First and Second Digit	Third and Fourth Digit	Fifth Digit	
	Pressure Ratio (xx:1)	Lower Construction	
			Built-in Filter
PL	45	C	Carbon Steel
	70		1
	80		2
	95		NA

Approvals:



Component Identification - Cart Mount

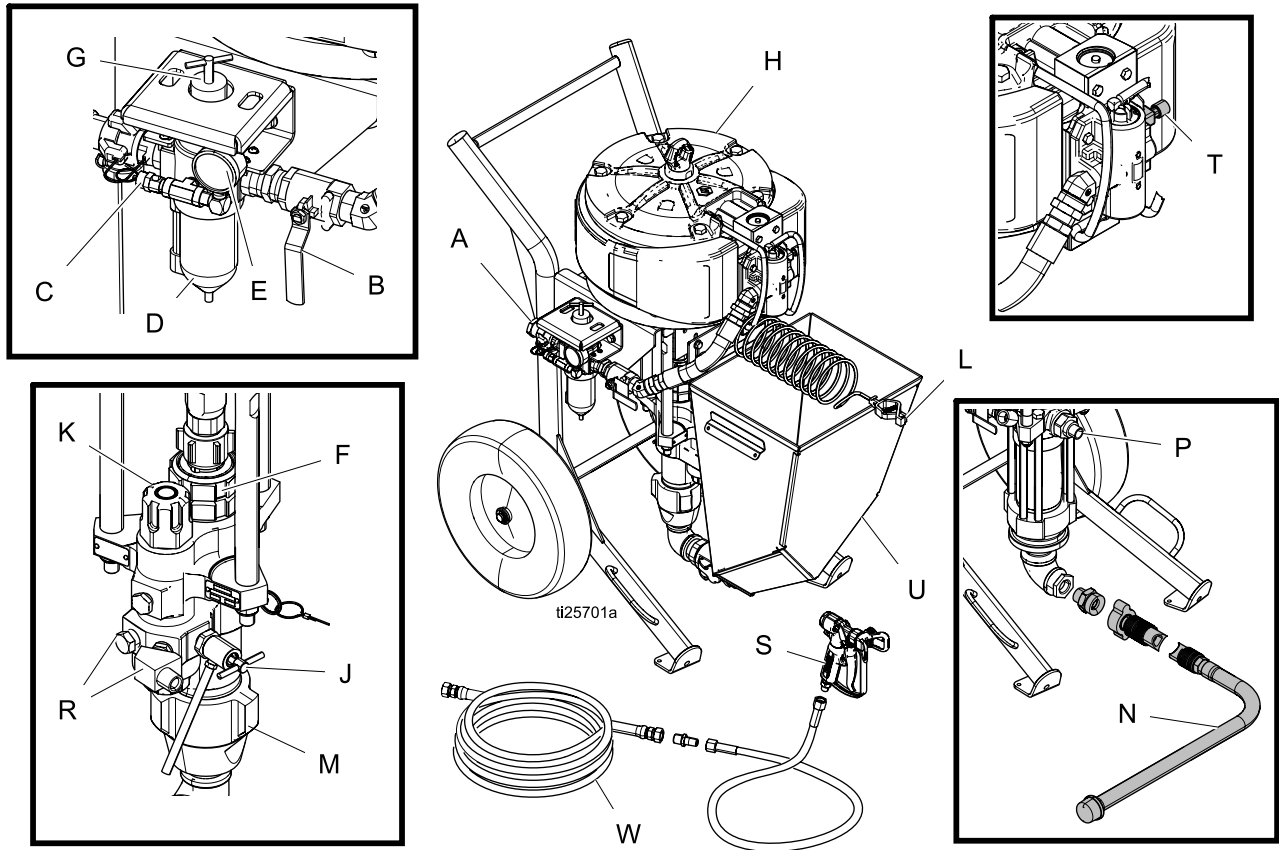

Figure 1 Airless Sprayer

Key:

- | | | | |
|---|--|---|---|
| A | Air Inlet, 1 in npt(f) on claw fitting | L | Grounding Wire (required) |
| B | Bleed Type Master Air Valve (required) | M | Pump |
| C | Air Pressure Relief Valve | N | Suction Hose and Tube (if equipped) |
| D | Air Filter / Water Separator | P | Pump Fluid Outlet |
| E | Air Pressure Gauge | R | Optional Fluid Outlet, for second spray gun |
| F | Packing Nut | S | Spray Gun |
| G | Air Regulator Adjustment | T | De-Ice Control (Bleed Air) |
| H | Air Motor | U | Hopper (if equipped) |
| J | Fluid Drain/Purge Valve (required) | W | Fluid Hose |
| K | Fluid Filter (if equipped) | | |

Component Identification - Wall Mount

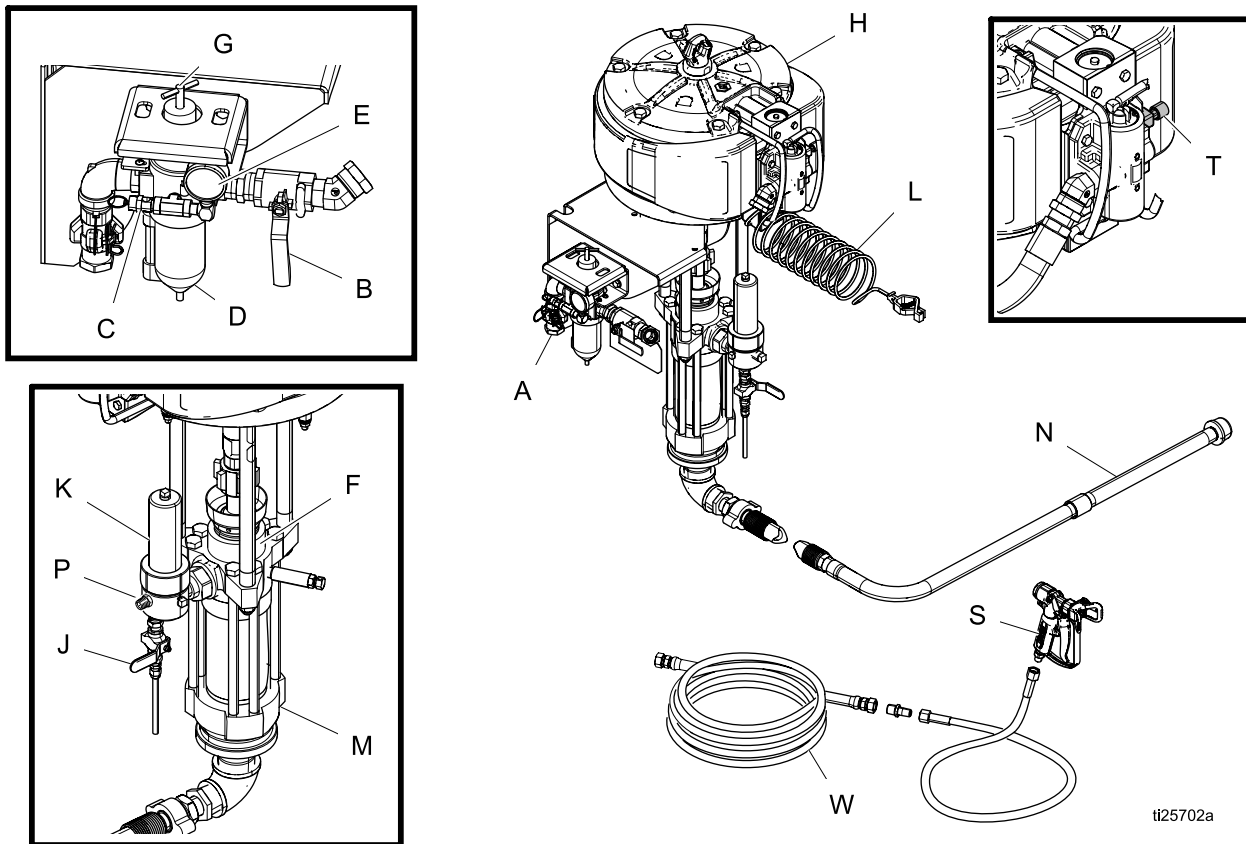

Figure 2 Airless Sprayer

Key:





- | | | | |
|---|--|---|----------------------------|
| A | Air Inlet, 1 in npt(f) on claw fitting | K | Fluid Filter (if equipped) |
| B | Bleed Type Master Air Valve (required) | L | Grounding Wire (required) |
| C | Air Pressure Relief Valve | M | Pump |
| D | Air Filter / Water Spearator | N | Suction Hose and Tube |
| E | Air Pressure Gauge | P | Fluid Outlet |
| F | Packing Nut | S | Spray Gun |
| G | Air Regulator Adjustment | T | De-Ice Control (Bleed Air) |
| H | Air Motor | W | Fluid Hose |
| J | Fluid Drain/Purge Valve (required) | | |

System Components

Note

* Required system components.

* Bleed Type Master Air Valve (B)

				
<p>Trapped air can cause the pump to cycle unexpectedly, which could result in serious injury from splashing or moving parts.</p>				

- Be sure the valve is easily accessible from the pump and located downstream from the air regulator.
 - Required in your system to relieve air trapped between it and the air motor when the valve is closed.
- Open the valve to supply air to the motor.
- Close the valve to shut off air to the motor, and bleed any trapped air from the motor.

* Air Pressure Relief Valve (C)

Automatically opens to relieve air pressure if supplied pressure exceeds preset limit.

* Air Filter (D)

Removes harmful dirt from compressed air supply. A minimum 40 micron filter is used.

Air Regulator Adjustment (G)

Adjusts air pressure to the motor and fluid outlet pressure of pump. Locate it close to the pump. Read air pressure on gauge (E).



* Fluid Drain/Purge Valve (J)

Open valve to relieve pressure and when flushing or priming pump. Close valve when spraying.

De-Ice Control (T)

Turn bleed air knob (open) to reduce icing.

Grounding

				
<p>The equipment must be grounded to reduce the risk of static sparking. Static sparking can cause fumes to ignite or explode. Grounding provides an escape wire for the electric current.</p>				

Tools Required:

- Grounding wires and clamps for pails
 - Two 5 gal. (19 liter) metal pails
1. Connect the ground wire (244524) (L) to the ground stud on the air motor.

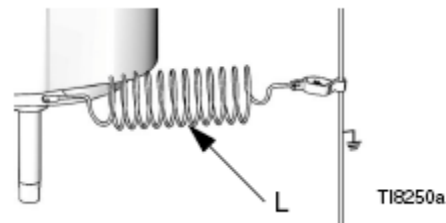

Figure 3

2. Connect the other end of the ground wire to a true earth ground.
3. Ground the object being sprayed, fluid supply container, and all other equipment in the work area. Follow your local code. Use only electrically conductive air and fluid hoses.
4. Ground all solvent pails. Use only metal pails, which are conductive, placed on a grounded surface. Do not place pail on a nonconductive surface, such as paper or cardboard, which interrupts grounding continuity.



T11102-1



T11102-2

Install Wall Mount Assembly

Note

Before mounting any pump assembly to the wall always follow the [Pressure Relief Procedure, page 14](#).

1. Ensure the wall is strong enough to support the weight of the pump assembly and accessories, fluid, hoses, and stress caused during pump operation.
2. Drill four 7/16 in. (11 mm) holes using bracket as a template. Use any of the three mounting hole groupings in the bracket. See [Dimensions, page 34](#).
3. Bolt bracket securely to wall using bolts and washers designed to hold in the wall's construction.
4. Attach pump assembly to mounting bracket (201).

5. Connect air and fluid hoses. Refer to [Setup, page 13](#).

Install Hopper Assembly

Note

If provided.

1. If necessary remove suction hose.
 - a. Disconnect suction hose (18).
 - b. Disconnect fitting (4) and quick disconnect adapter (19) from the pump.
2. Attach bracket (30) to the cart (9) with nuts (16) and screws (15).
3. Loosely attach bracket (29) to bracket (30) with nuts (16) and screws (15).
4. Install elbow (4) and fitting (8) on the pump.
5. Install fitting (32) and fitting (5) on hopper (7).
6. Connect fitting (5) to fitting (8). Adjust bracket (29) height to fit under the lip on the back of the hopper (7). Tighten nuts (16).

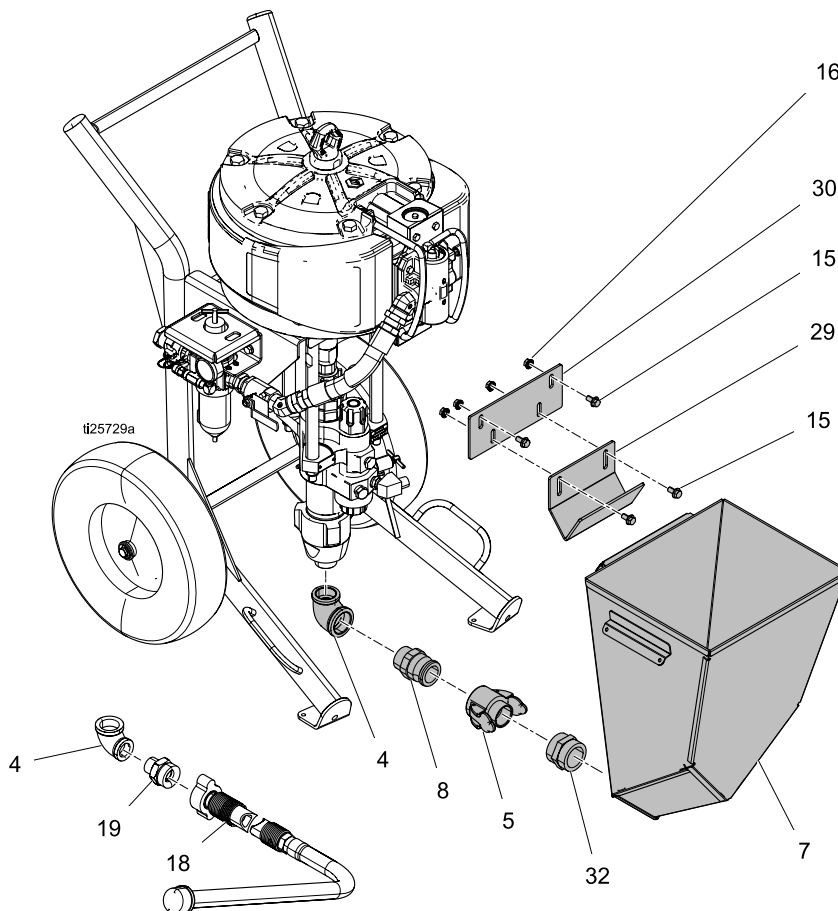

Setup

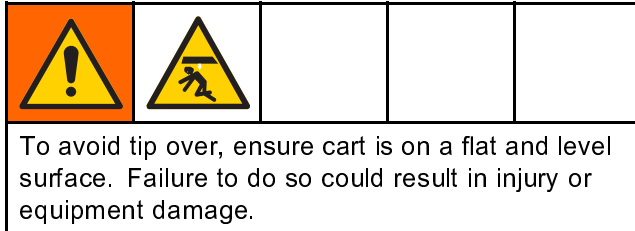

Tools Required:

- Two adjustable wrenches
 - Non-sparking hammer or plastic mallet
 - Torque wrench
1. Ground sprayer. See [Grounding, page 11](#).
 2. Check packing nut (F). Fill with Throat Seal Liquid (TSL). Torque to 25-30 ft-lb (34-41 N•m).

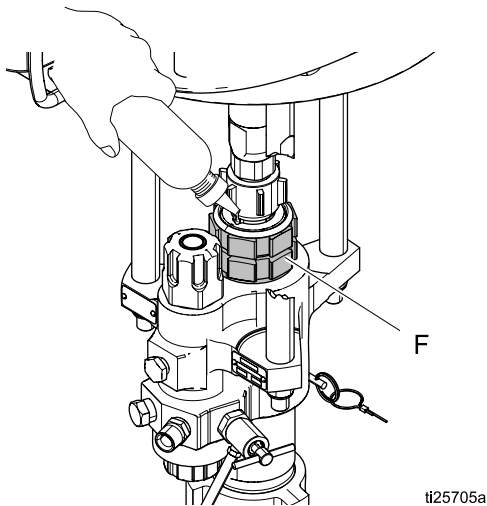

3. Attach electrically conductive fluid hose to pump outlet and tighten.
4. Attach electrically conductive fluid hose (and air hose if using an AA gun) to gun and tighten. Check that all pressure connections are tight.
5. Close bleed type master air valve (B). Connect air supply hose to 1 in npt(f) air inlet (A).

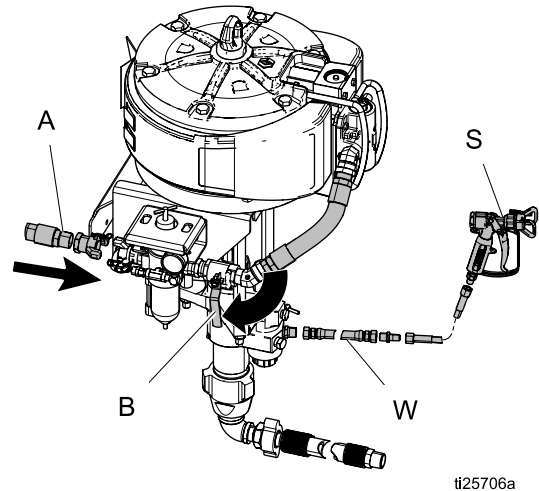

6. Flush and prime before using. See [Flush, page 15](#), and [Prime, page 17](#).

Pressure Relief Procedure



Follow the Pressure Relief Procedure whenever you see this symbol.

This equipment stays pressurized until pressure is manually relieved. To help prevent serious injury from pressurized fluid, such as skin injection, splashing fluid and moving parts, follow the Pressure Relief Procedure when you stop spraying and before cleaning, checking, or servicing equipment.

1. Engage gun trigger lock.



2. Close bleed type master air valve (B).

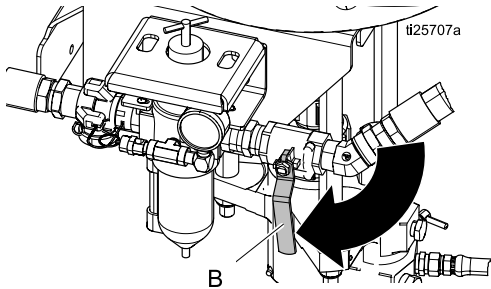

3. Disengage gun trigger lock.

Note

If using an AA gun, turn gun air regulator counter-clockwise to relieve pressure.

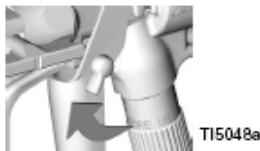

4. Hold gun firmly against a grounded metal pail. Trigger the gun until pressure is relieved.



5. Engage trigger lock.



6. Drain fluid. To drain fluid, slowly open all fluid drain valves, including drain/purge valve (J), in system into a waste pail. If there is a return tube, open return line ball valve. Close valve after fluid is drained.

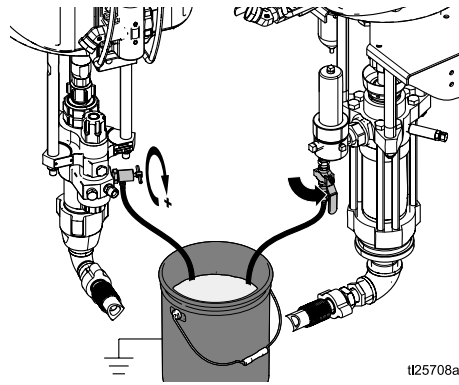

Left: Xtreme Lower	Right: Dura-Flo Lower
--------------------	-----------------------

7. If you suspect the spray tip or hose is clogged or that pressure has not been fully relieved.
 - a. VERY SLOWLY loosen tip guard retaining nut or hose end coupling to relieve pressure gradually.
 - b. Loosen nut or coupling completely.
 - c. Clear hose or tip obstruction.

Flush

To avoid fire and explosion, always ground equipment and waste container. To avoid static sparking and injury from splashing, always flush at lower possible pressure.

Flush the pump:

- Before first use
- When changing colors or fluids
- Before repairing equipment
- Before fluid dries or settles out in a dormant pump (check the pot life of catalyzed fluids)
- At the end of the day
- Before storing the pump

Flush at the lowest pressure possible. Flush with a fluid that is compatible with the fluid you are pumping and with the wetted parts in your system. Check with your fluid manufacturer or supplier for recommended flushing fluids and flushing frequency.

1. Follow [Pressure Relief Procedure](#), page 14.
2. Remove tip and tip guard from gun.
3. If desired, remove fluid filter. Reinstall filter cap after removing fluid filter.
4. Place suction tube in a compatible solvent.



Note

Do not stretch hose tight' let it hang to assist fluid flow into the pump.

5. Turn regulator adjustment knob (G) counterclockwise until it stops, and gauge (E) reads zero.

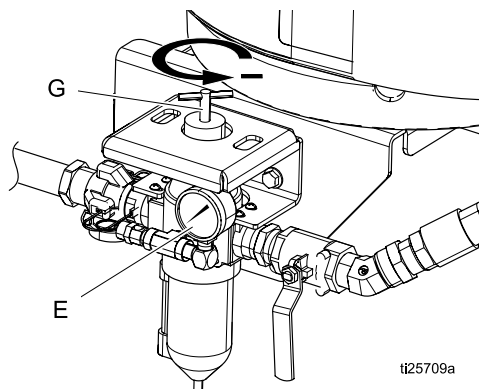

6. Open bleed type master valve (B).

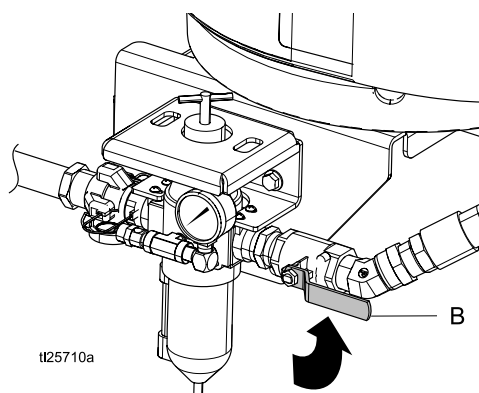

7. Flush hose and gun:
 - a. Disengage gun trigger lock. Hold the gun against a grounded metal pail.



Flush

- b. Trigger gun, slowly open regulator adjustment knob (G) until pump begins to cycle and a steady stream comes from gun. Trigger gun for 10-15 seconds.



Note

If using an AA gun, increase air pressure by turning gun regulator clockwise.

- b. Start the pump by rotating the air regulator adjustment knob (G) clockwise until pump begins to move.

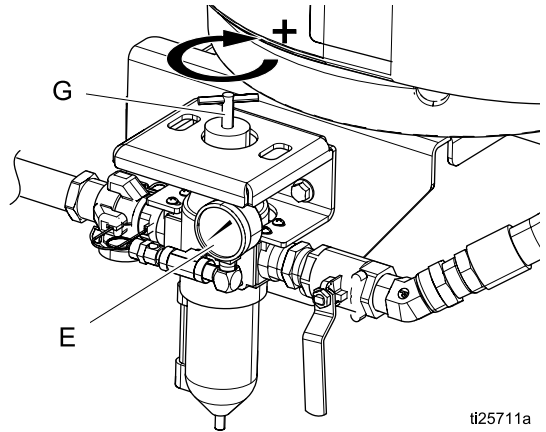

- c. After solvent is running clean, turn the regulator adjustment knob (G) counter clockwise until it stops and the gauge reads zero. The pump will stop. Once the material stops flowing, release the trigger and engage the trigger lock. Stop the pump with the rod buried in the pump.
- d. Close the bleed type master air valve.

- c. When clean solvent flows from drain tube close drain/purge valve (J) by rotating clockwise. Pump will stall.

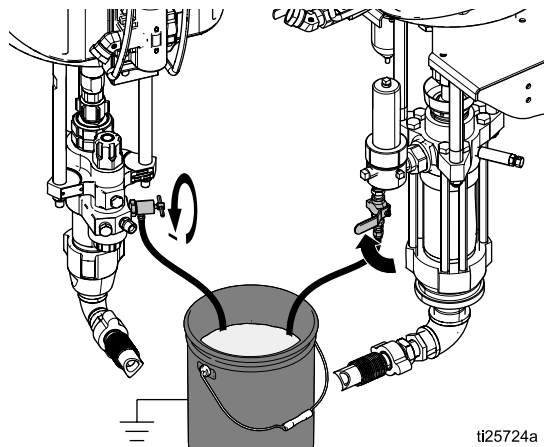

- 8. If flushing through drain/purge valve:
 - a. Place drain tube in a grounded waste pail. Open drain/purge valve (J) slightly by rotating counterclockwise.

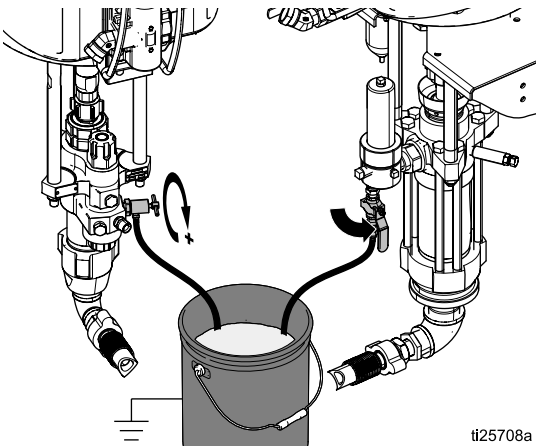

Left: Xtreme Lower	Right: Dura-Flo Lower
--------------------	-----------------------

Left: Xtreme Lower	Right: Dura-Flo Lower
--------------------	-----------------------

- d. Stop the pump with the rod buried in the pump.
 - e. Follow [Pressure Relief Procedure, page 14](#). Leave solvent in and store sprayer.
- 9. Remove fluid filter and soak in solvent. Replace filter cap.

Prime

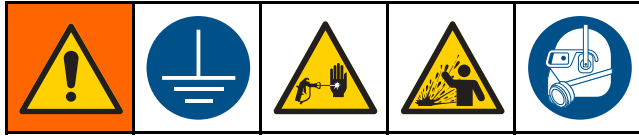

1. Follow [Pressure Relief Procedure](#), page 14.
2. Lock gun trigger. Remove tip and tip guard from gun.
3. Place suction tube in the material that will be sprayed.



Note

Do not stretch hose tight let it hang to assist fluid flow into the pump.

4. Turn regulator adjustment knob (G) counterclockwise until it stops, and gauge (E) reads zero.

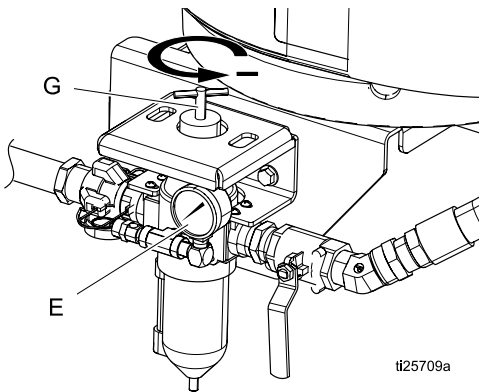

ti25709a

5. Open bleed type master valve (B).

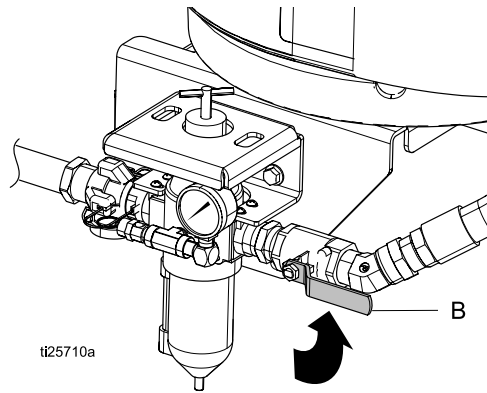

ti25710a

6. Prime through drain valve if necessary.

Note

Usually 1K high viscosity materials.

NOTICE

Do not prime pump through drain/purge valve using two component materials. Mixed two-component materials will harden in valve and result in clogging.

- a. Place drain tube in a grounded waste pail. Open drain/purge valve (J) slightly by rotating counterclockwise.

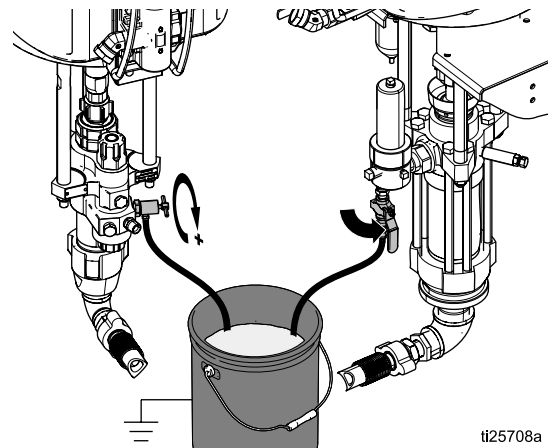

ti25708a

Left: Xtreme Lower	Right: Dura-Flo Lower
--------------------	-----------------------

Prime

- b. Start the pump by rotating the air regulator adjustment knob (G) clockwise until pump begins to move.

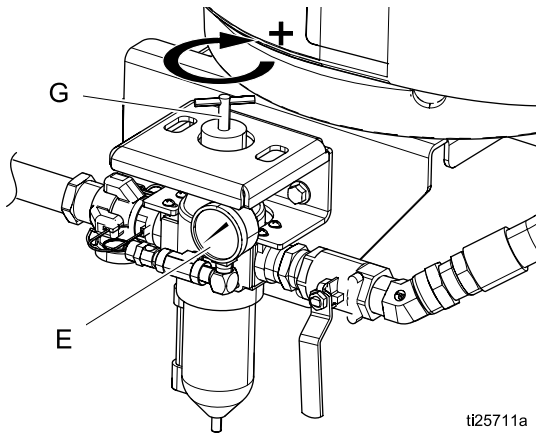

7. Prime hose and gun:

- a. Disengage gun trigger lock. Hold the gun against a grounded metal pail.

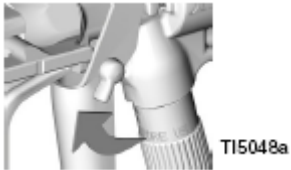

- b. Trigger gun, slowly open regulator adjustment knob (G) until pump begins to cycle and a steady stream comes from gun. Trigger gun for 10-15 seconds.



Note

If using an AA gun, increase air pressure by turning gun regulator clockwise.

- c. Engage trigger lock.
8. The equipment is now ready to spray; go to [Spray, page 19](#).

Spray

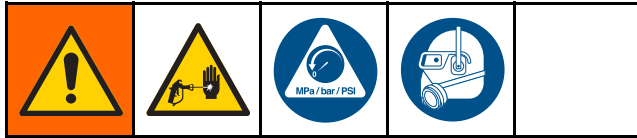

NOTICE

Do not allow pump to run dry. It will quickly accelerate to a high speed causing damage.

1. Prime. See [Prime](#), page 17.
2. Follow [Pressure Relief Procedure](#), page 14.
3. Install tip and tip guard on gun.
4. Open bleed type master air valve (B).

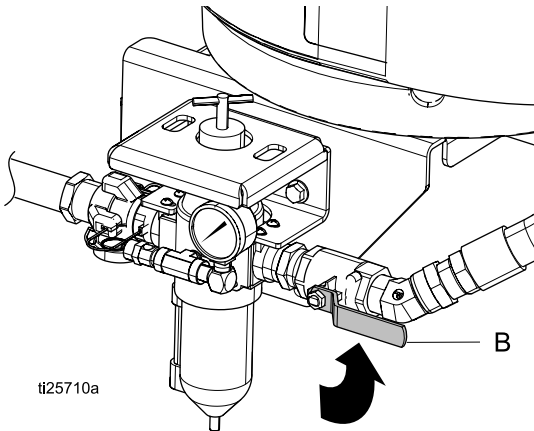

5. Turn regulator adjustment knob (G) until gauge (E) reads desired pressure. Turn clockwise to increase pressure, counterclockwise to decrease pressure.

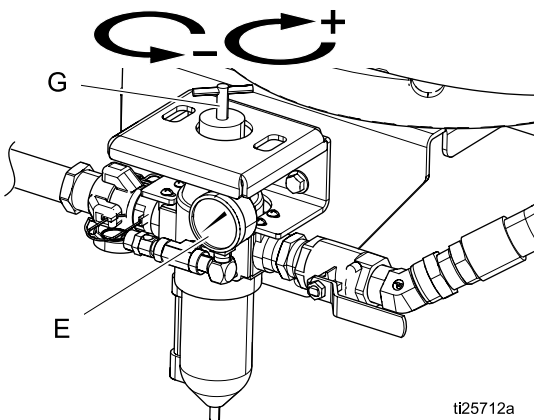

6. Disengage gun trigger lock.



7. Spray a test pattern. Read fluid manufacturer's recommendations. Adjust pressure as necessary. If using an AA gun, increase gun air pressure while testing spray pattern.



8. Flush when done spraying. See [Flush](#), page 15.
9. Follow [Pressure Relief Procedure](#), page 14.

Shutdown



NOTICE

Never leave water or water-base fluid in pump over night. If you are pumping water-base fluid, flush with water first, then with a rust inhibitor, such as mineral spirits. Relieve pressure, but leave rust inhibitor in pump to protect parts from corrosion.

Follow [Pressure Relief Procedure](#), page 14.

Always flush the pump before the fluid dries on the displacement pump rod. See [Flush](#), page 15.

Maintenance

Preventative Maintenance Schedule

The operating conditions of your particular system determine how often maintenance is required. Establish a preventive maintenance schedule by recording when and what kind of maintenance is needed, and then determine a regular schedule for checking your system.

Daily Maintenance



Note

For over night shutdown, stop pump at bottom of its stroke to prevent fluid from drying on exposed displacement rod and damaging throat packings. Follow [Pressure Relief Procedure, page 14](#).

1. Flush. See [Flush, page 15](#).
2. Relieve pressure. See [Pressure Relief Procedure, page 14](#).
3. Check packing nut (S). Adjust packings and replace TSL as necessary. Torque to 25-30 ft-lb (34-41 N•m).
4. Drain water from air filter.
5. Clean suction tube using a compatible solvent. It is recommended that you clean the outside of the sprayer using a cloth and compatible solvent.
6. Check hoses, tubes, and couplings. Tighten all fluid connections before each use.
7. Clean fluid line filter.

Corrosion Protection

Always flush the pump before the fluid dries on the displacement rod. Never leave water or water-based fluid in the pump overnight. First, flush with water or a compatible solvent, then with mineral spirits. Relieve the pressure, but leave the mineral spirits in the pump to protect the parts from corrosion.

Cart Maintenance

Periodically lubricate the axle between points A and B with lightweight oil.

Keep the cart clean by wiping up spills daily, using a compatible solvent

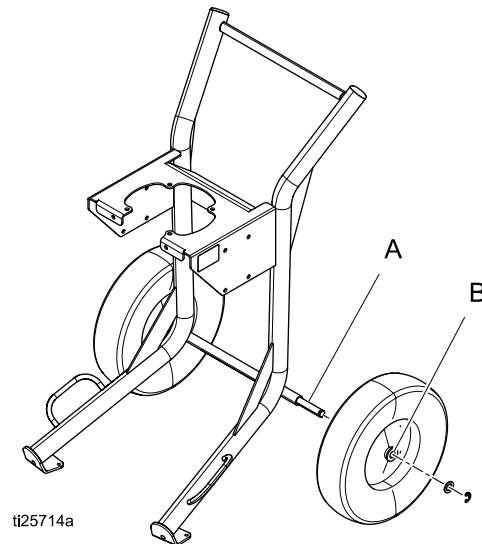

Troubleshooting

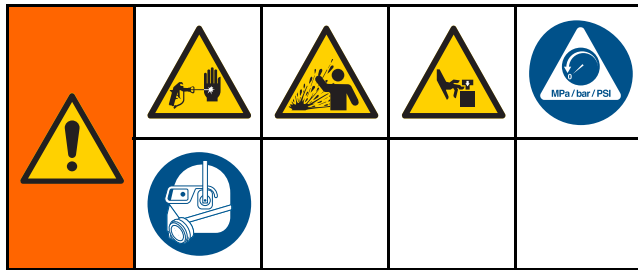

2. Check all possible causes and problems before disassembling pump.
 3. See air motor manual for air motor specific troubleshooting
- * To determine if fluid hose or gun is obstructed, follow [Pressure Relief Procedure, page 14](#). Disconnect fluid hose and place a container at pump fluid outlet to catch any fluid. Turn on air power just enough to start pump. If pump starts, the obstruction is in fluid hose or gun.

1. Follow [Pressure Relief Procedure, page 14](#).

Problem	Cause	Solution
Does not operate.	Valve closed or clogged.	Clear air line; increase air supply. Check that valves are open.
	Fluid hose or gun obstructed.	Clean hose or gun.*
	Dried fluid on displacement rod.	Clean rod; always stop pump at bottom of stroke; keep wet-cup filled with compatible solvent.
	Air motor parts dirty, worn, or damaged.	Clean or repair air motor. See motor manual.
Output low on both strokes.	Air line restricted or air supply inadequate. Valves closed or clogged.	Clear air line; increase air supply. Check that valves are open.
	Fluid hose/gun obstructed; hose ID too small.	Clear hose or gun*; use hose with larger ID.
	Air motor icing.	Open De-Ice control.
Output low on down stroke.	Open or worn intake valve.	Clear or service intake valve.
	High viscosity fluid.	Adjust intake spacers.
Output low on upstroke.	Open or worn piston valve or packings.	Clear piston valve; replace packings.
Erratic accelerated speed.	Fluid supply exhausted, clogged suction.	Refill supply and prime pump. Clean suction tube.
	High viscosity fluid.	Reduce viscosity; adjust intake spacers.
	Open or worn piston valve or packings.	Clear piston valve; replace packings.
	Open or worn intake valve.	Clear or service intake valve.
Runs sluggishly.	Possible icing.	Stop pump. Open De-Ice control.
Cycles or fails to hold pressure at stall.	Worn check valves or seals.	Service lower. See Remove Lower, page 22 , and Xtreme Lowers manual (311762).
Air bubbles in fluid.	Loose suction line.	Tighten. Use compatible liquid thread sealant or PTFE tape on connections.
Poor finish or irregular spray pattern.	Incorrect fluid pressure at gun.	See gun manual; read fluid manufacturer's recommendations.
	Fluid is too thin or too thick.	Adjust fluid viscosity; read fluid manufacturer's recommendations.

Remove Lower

Required Tools

- Set of adjustable wrenches
- Torque wrench
- Rubber mallet
- Thread lubricant
- Anti-seize lubricant 222955
- Loctite® 2760™ or equivalent

Disconnect and Reconnect Lower

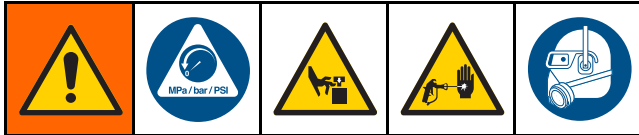

1. Flush pump; see [Flush, page 15](#). Stop pump at bottom of its stroke. Follow [Pressure Relief Procedure, page 14](#).
2. Disconnect air hose.
3. Disconnect fluid hose (W). Hold fluid outlet fitting (P) with a wrench to keep it from loosening while you disconnect suction hose (N).
4. Note the relative position of lower's fluid outlet (P) to inlet (X) of motor for easier reassembly alignment. If motor does not require service, leave it attached to its mounting.

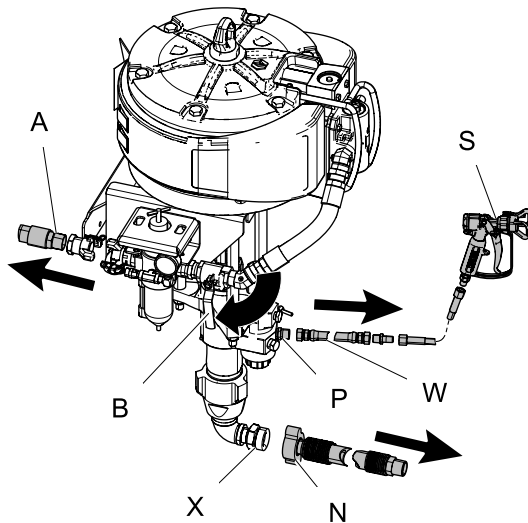

ti25715a

5. Hold the flats of the air motor piston rod with a wrench. Use another wrench to loosen the coupling nut (CN).

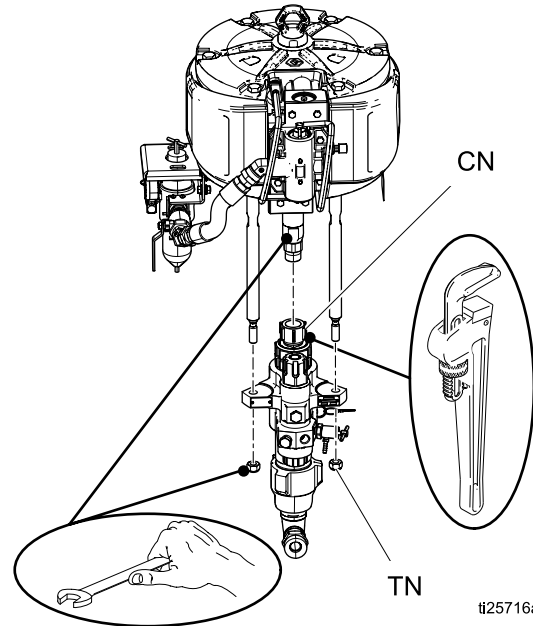

ti25716a

6. Remove the tie rod nuts (TN).
7. Remove lower. Refer to the Lower manual to service lower. To service motor, refer to separate motor manual.
8. Reconnect lower by following disconnect steps in reverse order.

Note

Torque nuts (308) to 50-60 ft-lb (68-81 N•m).

Parts

Xtreme Sprayer Cart Packages

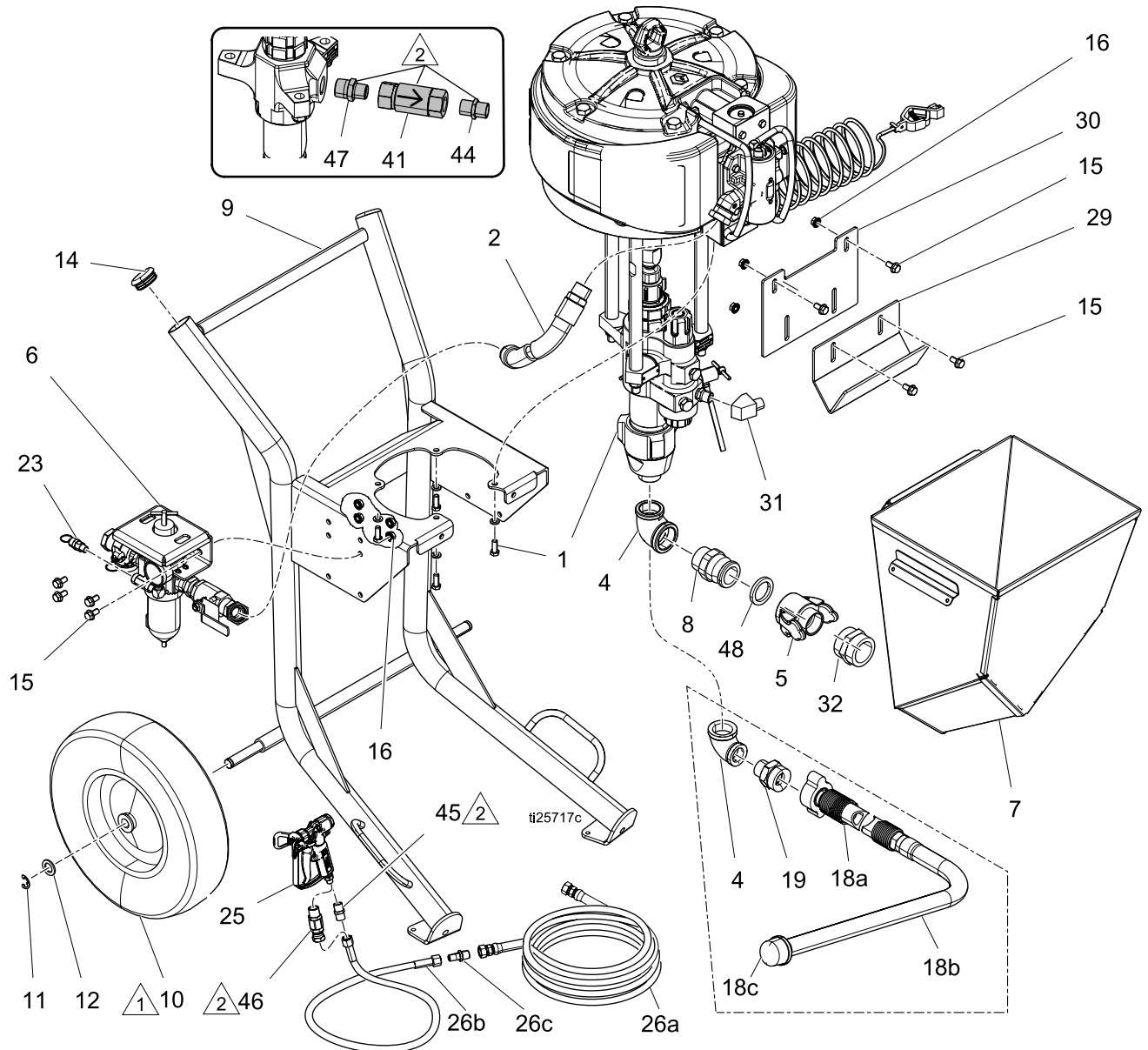

- △₁ Apply grease to cart axles before assembling wheels.
- △₂ For heavy fluid packages 24X593 and 24X594 only.
- 3. Apply anaerobic pipe sealant to all non-swiveling pipe threads.

Xtreme Packages Without A Hopper

Ref	Part	Description	Sprayer Description and Quantity								
			No Hose and Gun						With Hose and Gun		
			No Hopper			No Hopper, No filter			No Hopper		
			XL70H1	XL80H1	XL95H1	XL70H4	XL80H4	XL95H4	XL70H2	XL80H2	XL95H2
1	PL95C2 ■	PUMP, xtreme, xl, 220; Pump Package Parts, page 32			1						1
	PL95C1	PUMP, xtreme, xl, 220; Pump Package Parts, page 32						1			
	PL80C2 ■	PUMP, xtreme, xl, 250; Pump Package Parts, page 32		1						1	
	PL80C1	PUMP, xtreme, xl, 250; Pump Package Parts, page 32					1				
	PL70C2 ■	PUMP, xtreme, xl, 290; Pump Package Parts, page 32	1						1		
	PL70C1	PUMP, xtreme, xl, 290; Pump Package Parts, page 32				1					
2	278770	HOSE, coupled	1	1	1	1	1	1	1	1	1
4	116401	ADAPTER, elbow	1	1	1	1	1	1	1	1	1
6	24W593	MODULE, air controls; see manual 3A0293	1	1	1	1	1	1	1	1	1
9*	24Y078	CART, heavy duty	1	1	1	1	1	1	1	1	1
10*	113362	WHEEL, semi- pneumatic	2	2	2	2	2	2	2	2	2
11*	113436	RING, retaining	2	2	2	2	2	2	2	2	2
12*	154628	WASHER	2	2	2	2	2	2	2	2	2
14*	113361	CAP, tube, round	2	2	2	2	2	2	2	2	2

Ref	Part	Description	Sprayer Description and Quantity								
			No Hose and Gun						With Hose and Gun		
			No Hopper			No Hopper, No filter			No Hopper		
			XL70H1	XL80H1	XL95H1	XL70H4	XL80H4	XL95H4	XL70H2	XL80H2	XL95H2
15	112395	SCREW, cap, flng hd	4	4	4	4	4	4	4	4	4
16	112958	NUT, hex, flanged	4	4	4	4	4	4	4	4	4
18a	247301	HOSE; 1 in. x 6 ft	1	1	1	1	1	1	1	1	1
18b	197682	TUBE, siphon	1	1	1	1	1	1	1	1	1
18c	181072	STRAINER	1	1	1	1	1	1	1	1	1
19	116402	ADAPTER, qconnect	1	1	1	1	1	1	1	1	1
23	113498	VALVE, safety, 110 psi	1			1			1		
	120306	VALVE, safety, 85 psi			1			1			1
	16M190	VALVE, safety, 95psi		1			1			1	
25	XTR704	GUN, xtr7, 1" hnd, 4 fng, xhdrc							1	1	1
26a	H73850	HOSE; 3/8 x 50 ft							1	1	1
26b	H72506	HOSE; 1/4 x 6 ft									
26c	164856	NIPPLE, 3/8 x 1/4									

* Included in Cart Kit (9).

■ Includes Built-In Filter.

Xtreme Packages With A Hopper

Ref	Part	Description	Sprayer Description and Quantity				
			With Hose and Gun				
			Hopper				
			24X593	24X594	XL70H3	XL80H3	XL95H3
1	PL95C2	PUMP, xtreme, xl, 220; ■ Pump Package Parts, page 32					1
	PL80C2	PUMP, xtreme, xl, 250; ■ Pump Package Parts, page 32				1	
	PL70C2	PUMP, xtreme, xl, 290; ■ Pump Package Parts, page 32			1		
	PL70C1	PUMP, xtreme, xl, heavy duty; Pump Package Parts, page 32	1				
	PL80C1	PUMP, xtreme, xl, heavy duty; Pump Package Parts, page 32		1			
2	278770	HOSE, coupled	1	1	1	1	1
4◆	126939	FITTING, elbow, 90°, female, reducing	1	1	1	1	1
5◆	128095	FITTING, cam and groove; 1.5 npt(m)	1	1	1	1	1
6	24W593	MODULE, air controls; see manual 3A0293	1	1	1	1	1
7◆	17E114	HOPPER	1	1	1	1	1
8◆	17C692	FITTING, cam/groove, 1.5m, 1-1/2 npt	1	1	1	1	1
9*	24Y078	KIT, cart, heavy duty	1	1	1	1	1
10*	113362	WHEEL, semi-pneumatic	2	2	2	2	2
11*	113436	RING, retaining	2	2	2	2	2
12*	154628	WASHER	2	2	2	2	2
14*	113361	CAP, tube, round	2	2	2	2	2
15◆	112395	SCREW, cap, flng hd	8	8	8	8	8
16◆	112958	NUT, hex, flanged	8	8	8	8	8
23	113498	VALVE, safety, 110 psi	1		1		
	120306	VALVE, safety, 85 psi		1			1
	16M190	VALVE, safety, 95psi				1	
25●	XTR704	GUN, xtr 7, 1" hnd, 4 fng, xhdrac			1	1	1
	262854	GUN, XHF	1	1			
26a	H77550	HOSE, coupled, 7250 psi, 3/4 in ID; 50 ft	1	1			
	H73850	HOSE, coupled, 7250 psi, 3/8 in ID; 50 ft			1	1	1
26b	H75025	HOSE, coupled, 7250 psi, 1/2 in ID; 50 ft	1	1			
	H72506	HOSE, coupled, 7250 psi, 1/4 in ID; 6 ft			1	1	1
26c	16R883	FITTING, nipple, reducing, 3/4 x 1/2	1	1			
	164856	FITTING, nipple, 3/8 x 1/4			1	1	1
29◆	- - -	BRACKET, hopper	1	1	1	1	1
30◆	- - -	BRACKET, hopper, upper	1	1	1	1	1
31	15M987	FITTING, elbow, 60 deg	1	1	1	1	1

Ref	Part	Description	Sprayer Description and Quantity				
			With Hose and Gun				
			Hopper				
			24X593	24X594	XL70H3	XL80H3	XL95H3
32◆	- - -	FITTING, bushing, 1-1/2	1	1	1	1	1
41	16T480	VALVE, check	1	1			
44	160032	FITTING, nipple; 3/4-14 npt	1	1			
45●	158491	FITTING, nipple; 1/2-14 npt	1	1			
46●	24P834	SWIVEL, straight, PTFE	1	1			
47	171439	NIPPLE, pipe, reducing	1	1			
48	17C453	GASKET, 2 in. (packet 6)	1	1	1	1	1

■ Includes Built-In Filter.

* Included in Cart Kit 24Y078.

◆ Included in Hopper Kit 24X570.

● Included in the Hose and Gun Kit 24X553.

Dura-Flo Cart Packages

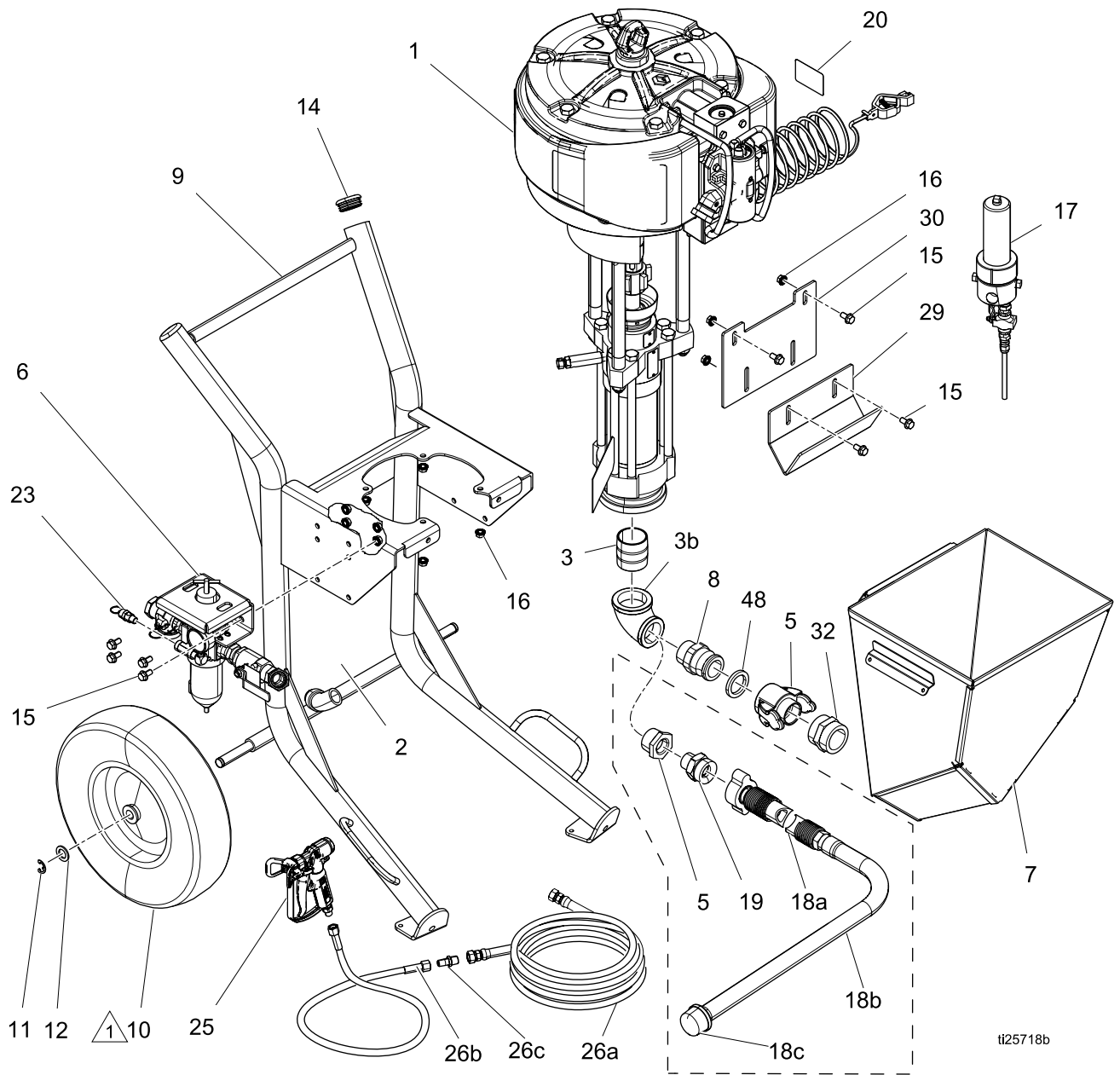

ti25718b

- △₁ Apply grease to cart axles before assembling wheels.
- 2. Apply anaerobic pipe sealant to all non-swiveling pipe threads.

Dura-Flo Cart Package Parts

Ref	Part	Description	Quantity			
			No Hose and Gun		With Hose and Gun	
			No Hopper	No Hopper, No Filter	No Hopper	With Hopper
			XL45H1	XL45H4	XL45H2	XL45H3
1	PL45C1	PUMP, duraflo, xl, 430, nf; Pump Package Parts, page 32	1	1	1	1
2	128093	HOSE, coupled	1	1	1	1
3a	24X547	KIT, fitting, nipple, 2 in. npt x 2.5 in.	1	1	1	1
3b	---	PIPE, elbow female; 2 x 1.5	1	1	1	1
5	15T271	BUSHING, 1.5 x 1 npt reducer sst	1	1	1	
	128095	FITTING, cam and groove				1
6	24W040	MODULE, air controls; see manual 3A0293	1	1	1	1
7	16U536	HOPPER, weldment				1
8	17C692	FITTING, cam/groove, 1.5m, 1-1/2npt				1
9*	24Y078	CART, heavy duty	1	1	1	1
10*	113362	WHEEL, semi-pneumatic	2	2	2	2
11*	113436	RING, retaining	2	2	2	2
12*	154628	WASHER	2	2	2	2
14*	113361	CAP, tube, round	2	2	2	2
15	112395	SCREW, cap, flng hd	4	4	4	8
16	112958	NUT, hex, flanged	4	4	4	8
17	238620	FILTER, paint	1		1	1
18	24T757	HOSE, w/siphon, xtreme	1	1	1	
19	116402	ADAPTER, qconnect	1	1	1	
20	---	LABEL, identification	1	1	1	1
23	114055	VALVE, safety, 105 psi	1	1	1	1
25	XTR504	GUN, xtr5, 1" hnd, 4 fng, xhdrac			1	1
26	24T755	HOSE SET, xtreme, 5600 psi			1	1
29	17C474	BRACKET, hopper				1
30	17D554	BRACKET, hopper, upper				1
32	128094	FITTING, bushing, 1-1/2				1
48	17C453	GASKET, 2 in. (pack of 6)				1

* Included in Cart Kit 24Y078.

Wall Mount Packages

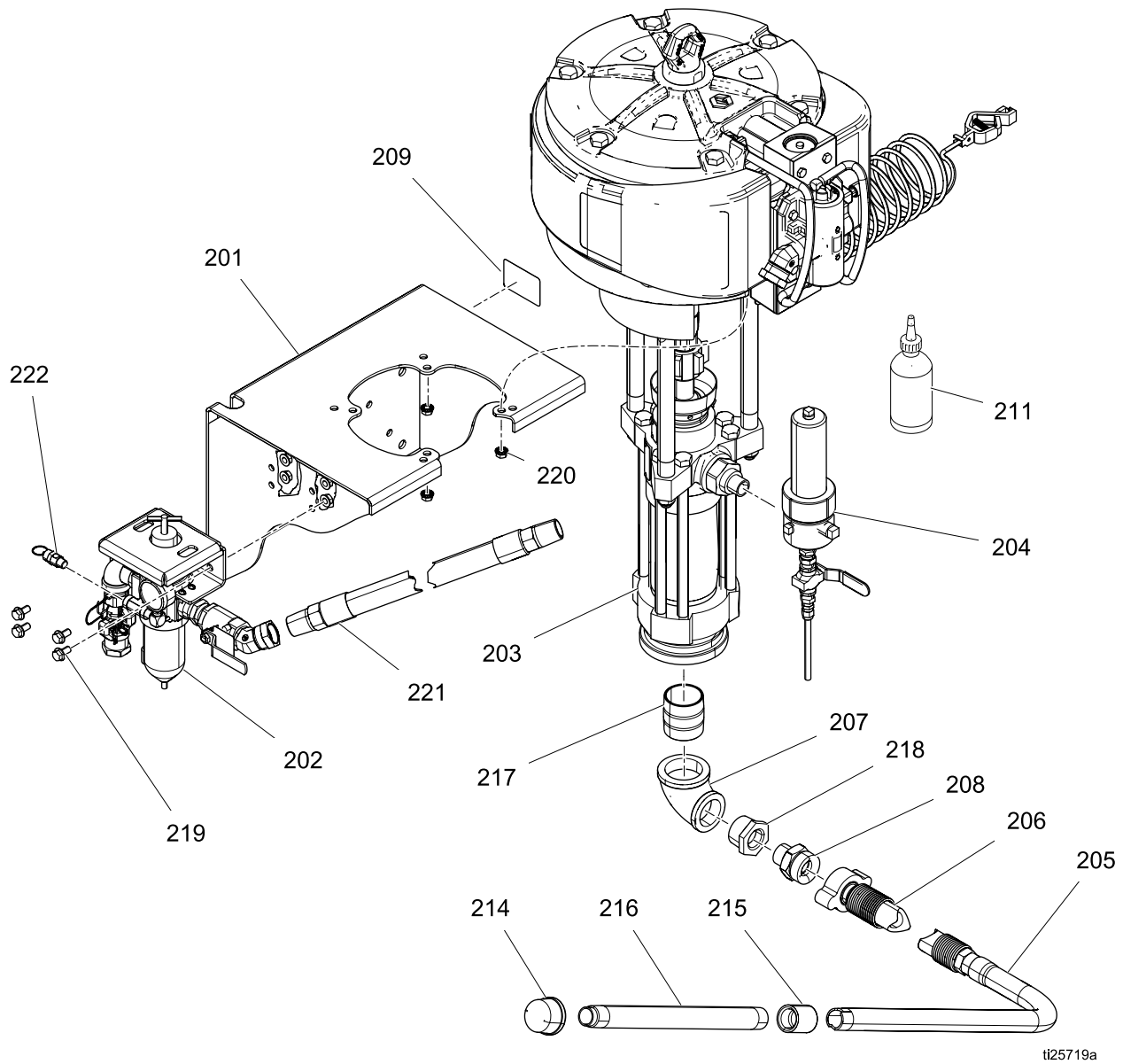

1. Apply stainless steel pipe sealant to all non-swiveling pipe threads.

Wall Mount Package Parts

Ref	Part	Description	Quantity			
			XL45W1	XL70W1	XL80W1	XL95W1
201	24X181	BRACKET, wall, xl	1	1	1	1
202	24W593	MODULE, air controls, wall; see manual 3A0293	1	1	1	1
203	PL45C1	PUMP, duraflo, xl, 430; Pump Package Parts, page 32	1			
	PL95C2■	PUMP, xtreme, xl, 220; Pump Package Parts, page 32				1
	PL80C2■	PUMP, xtreme, xl, 250; Pump Package Parts, page 32			1	
	PL70C2■	PUMP, xtreme, xl, 290; Pump Package Parts, page 32		1		
204	238620	FILTER, paint	1			
205	197682	TUBE, suction	1	1	1	1
206	247302	HOSE, suction, 1 in npt x qconnect	1	1	1	1
207	116401	ADAPTER, elbow		1	1	1
	120291	PIPE, elbow female	1			
208	116402	ADAPTER, qconnect	1	1	1	1
210	- - -	LABEL, identification	1	1	1	1
211	206994	FLUID, tsl 8 oz bottle	1	1	1	1
214	187147	STRAINER, inlet	1	1	1	1
215	114967	COUPLING, pipe, 1"	1	1	1	1
216	195151	TUBE, intake	1	1	1	1
217a	24X547	KIT, nipple, 2 in npt	1			
217b	- - -	ELBOW, 1.5 x 2 np	1			
218	121239	BUSHING, 1.5 x 1 npt reducer sst	1			
219	112395	SCREW, cap, flng hd	4	4	4	4
220	112958	NUT, hex, flanged	4	4	4	4
221	128093	HOSE, coupled	1			
	278770	HOSE, coupled		1	1	1
222	113498	VALVE, safety, 110 psi		1		
	120306	VALVE, safety, 85 psi				1
	16M190	VALVE, safety, 95 psi			1	
	114055	VALVE, safety, 105 psi	1			

■ Includes Built-In Filter.

Pump Package Parts

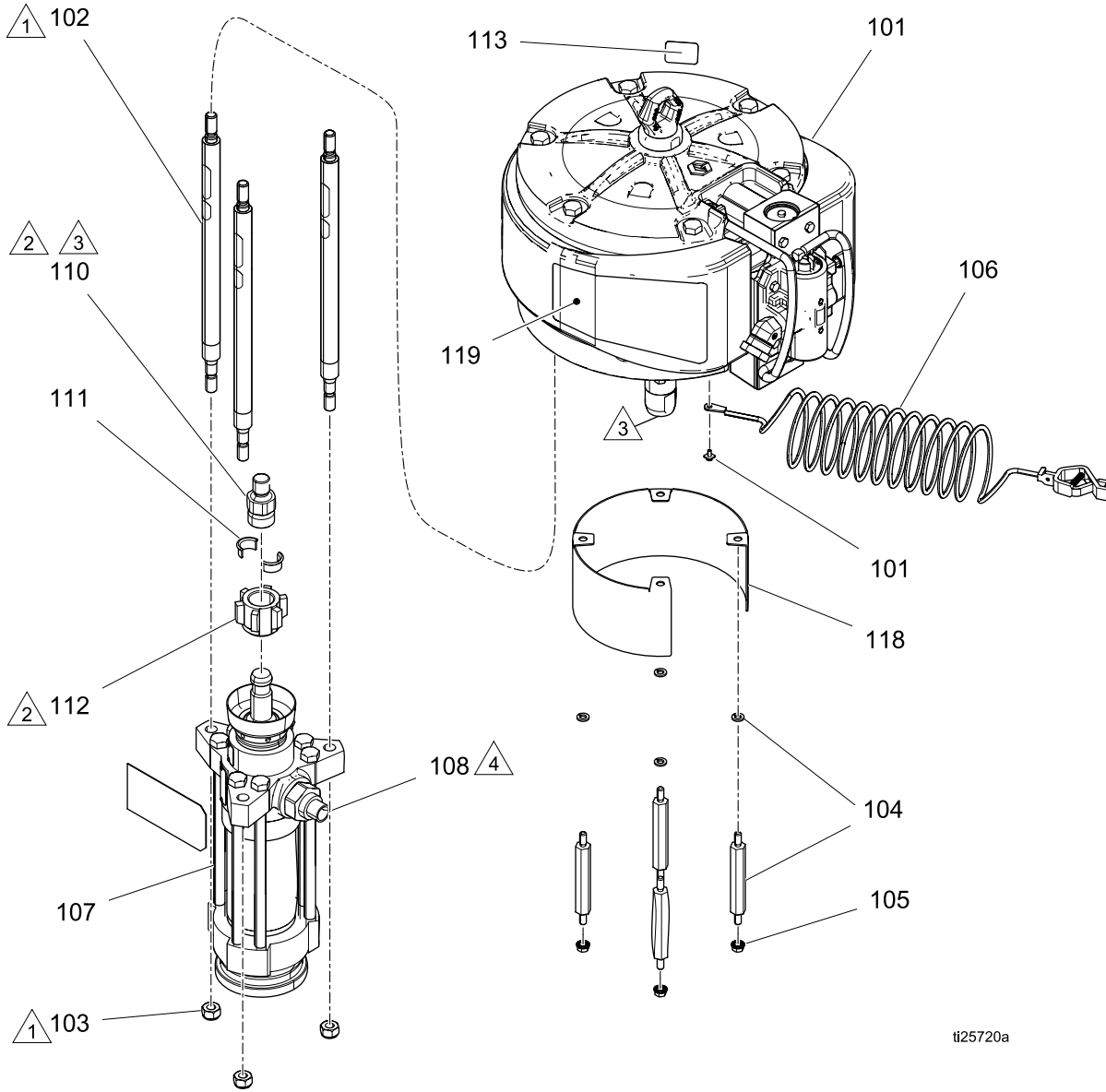

ti25720a

- △₁ Torque to 95–105 ft-lb (129–142 N•m).
- △₂ Torque to 230–250 ft-lb (312–340 N•m).

- △₃ Apply anaerobic pipe sealant.
- △₄ Apply stainless steel pipe sealant to all non-swiveling pipe threads.

Pump Package Parts

Ref	Part	Description	Quantity						
			PL45C1	PL70C1	PL70C2	PL80C1	PL80C2	PL95C1	PL95C2
101	24X856	MOTOR, air, 13 in.; includes 101a; see manual 334644	1	1	1	1	1	1	1
101a▲	15F674	LABEL, safety, motor (not shown)	1	1	1	1	1	1	1
102	184382	ROD, tie	3						
	17A048	ROD, tie, m16 x 2.0		3	3	3	3	3	3
103	15U606	NUT, lock, m16 x 2	3	3	3	3	3	3	
104	100133	WASHER, lock, 3/8		4	4	4	4	4	4
	120465	SPACER, mounting, threaded	4						
105	112958	NUT, hex, flanged	4						
	100101	SCREW, cap, hex hd		4	4	4	4	4	4
106	244524	WIRE, ground assy with clamp	1	1	1	1	1	1	
106a▲	290079	TAG, warning, grounding (not shown)	1	1	1	1	1	1	
107	24W644	LOWER, duraflo, 3/4, (18cm-cstl); see manual 311825	1						
	L22HC1	LOWER, xtreme, xl, 220; see manual 311762						1	
	L22HC2■	LOWER, xtreme, xl, 220; see manual 311762							1
	L25HC1	LOWER, xtreme, xl, 250; see manual 311762				1			
	L25HC2■	LOWER, xtreme, xl, 250; see manual 311762					1		
	L29HC1	LOWER, xtreme, xl, 290; see manual 311762		1					
	L29HC2■	LOWER, xtreme, xl, 290; see manual 311762			1				
108	171439	NIPPLE, pipe, rdcg		1		1		1	
110	184583	ADAPTER, rod		1	1	1	1	1	1
	184582	ADAPTER, rod	1						
111	184129	COLLAR, coupling		2	2	2	2	2	2
	184130	COLLAR, coupling	2						
112	184098	NUT, coupling		1	1	1	1	1	1
	184096	NUT, coupling	1						
118	15K296	SPACER	1						
120▲	172479	TAG, warning, lower (not shown)	1	1	1	1	1	1	

■ *Includes Built-In Filter.*

HD *Not for sale. Purchase individual parts as necessary.*

▲ *Replacement Warning labels, signs, tags, and cards are available at no cost.*

Dimensions

Sprayer Cart Packages

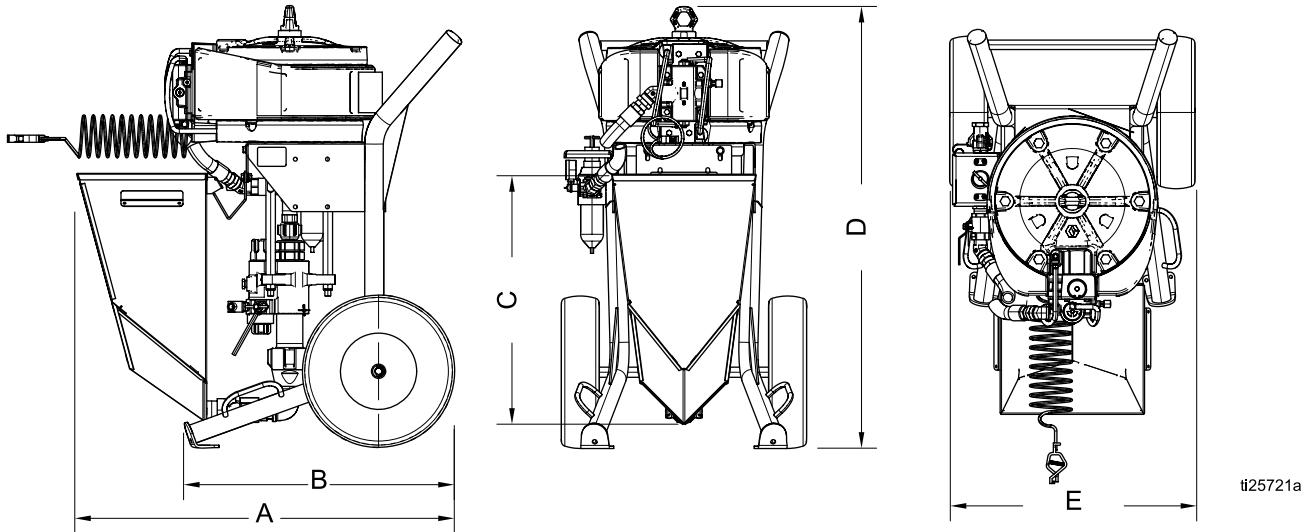

Mount	A	B	C	D	E
Dura-Flo	40.75 in (1035.05 mm)	28.5 in (723.9 mm)	26.25 in (666.75 mm)	46.25 in (1174.75 mm)	25.75 in (654.05 mm)
Xtreme	40.75 in (1035.05 mm)	28.5 in (723.9 mm)	26.25 in (666.75 mm)	51 in (1295.4 mm)	25.75 in (654.05 mm)

Wall Mount and Pump Packages

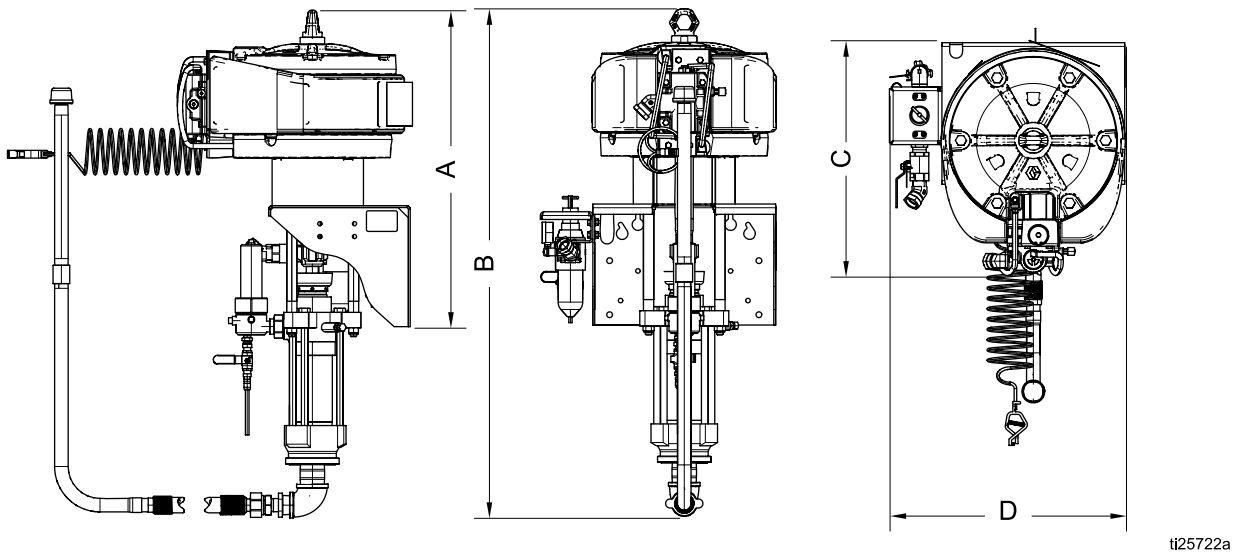

Mount	A	B	C	D
Dura-Flo	30.75 in (781.05 mm)	49.25 in (1250.95 mm)	22 in (558.8 mm)	23 in (584.2 mm)
Xtreme	26.25 in (666.75 mm)	43.5 in (1104.9 mm)	22 in (558.8 mm)	23 in (584.2 mm)

Wall Mount Bracket Mounting Hole Diagram

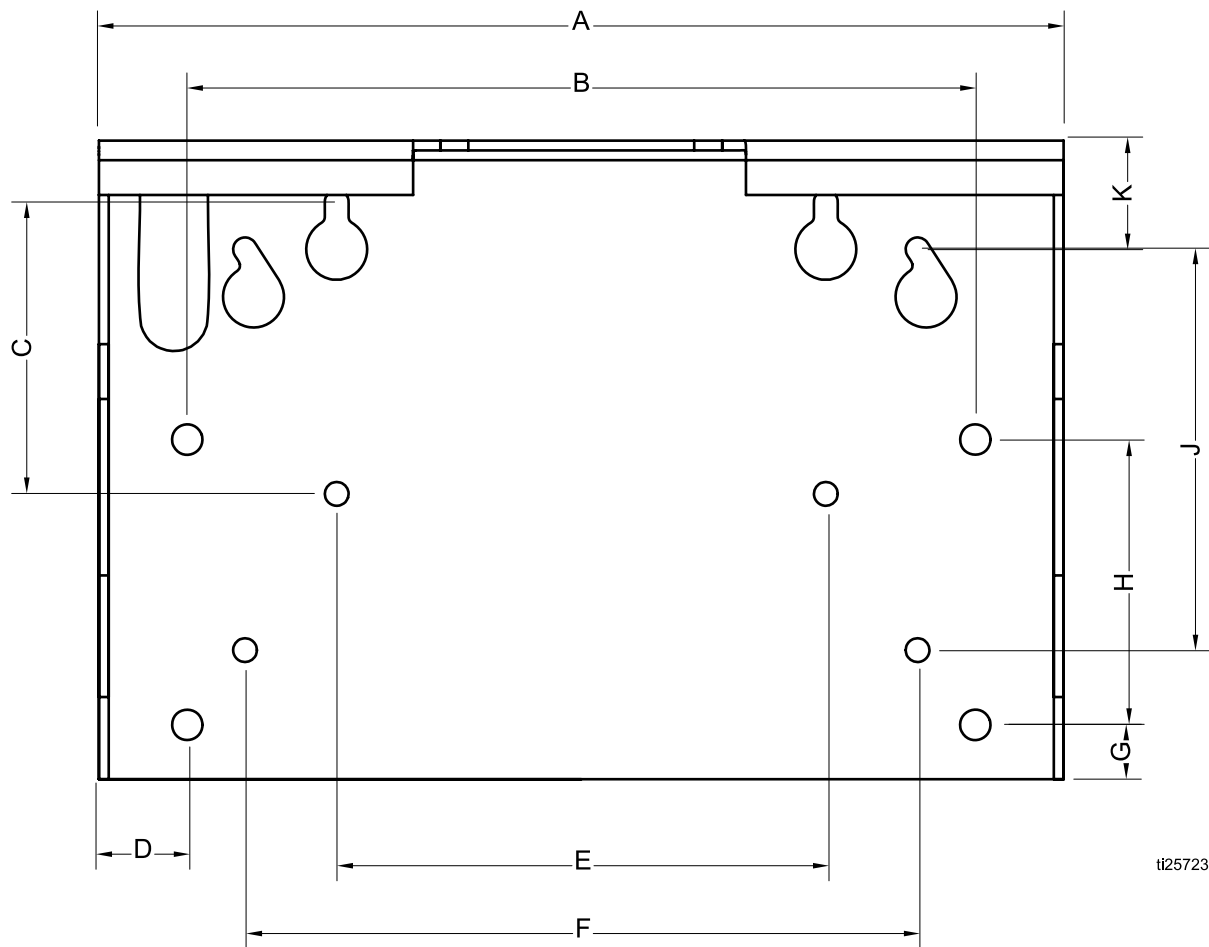

ti25723a

1	1/2 in (12.7 mm) diameter holes for mounting to stand
2	7/16 in (11 mm) diameter holes for mounting to wall
A	17.8 in (450.9 mm)
B	14.5 in (368.3 mm)
C	5.4 in (136.5 mm)
D	1.6 in (41.4 mm)
E	9 in (228.6 mm)
F	12.4 in (314.3 mm)
G	1 in (25.4 mm)
H	5.3 in (133.4 mm)
J	7.4 in (187.3 mm)
K	2 in (50.8 mm)

Performance Charts

Calculate Fluid Outlet Pressure

To calculate fluid outlet pressure (psi/MPa/bar) at a specific fluid flow (gpm/lpm) and operating air pressure (psi/MPa/bar), use the following instructions and pump data charts.

1. Locate desired flow along bottom of chart.
2. Follow vertical line up to intersection with selected fluid outlet pressure curve. Follow left to scale to read fluid outlet pressure.

Calculate Pump Air Flow/Consumption

To calculate pump air flow/consumption (scfm or m³/min) at a specific fluid flow (gpm/lpm) and air pressure (psi/Mpa/bar), use the following instructions and pump data charts.

1. Locate desired flow along bottom of chart.
2. Follow vertical line up to intersection with selected fluid outlet pressure curve. Follow right to scale to read air flow consumption.

Key: Air Pressure

A	100 psi (0.7 MPa, 7 bar)
B	70 psi (480 kPa, 4.8 bar)
C	40 psi (280 kPa, 2.8 bar)

45:1

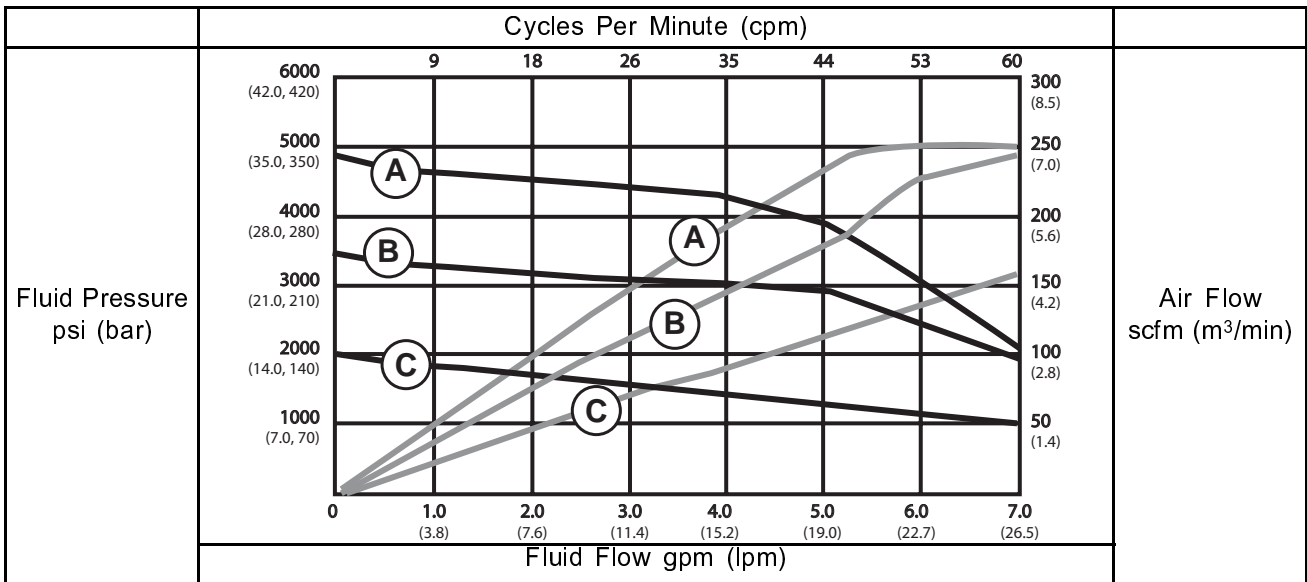

70:1

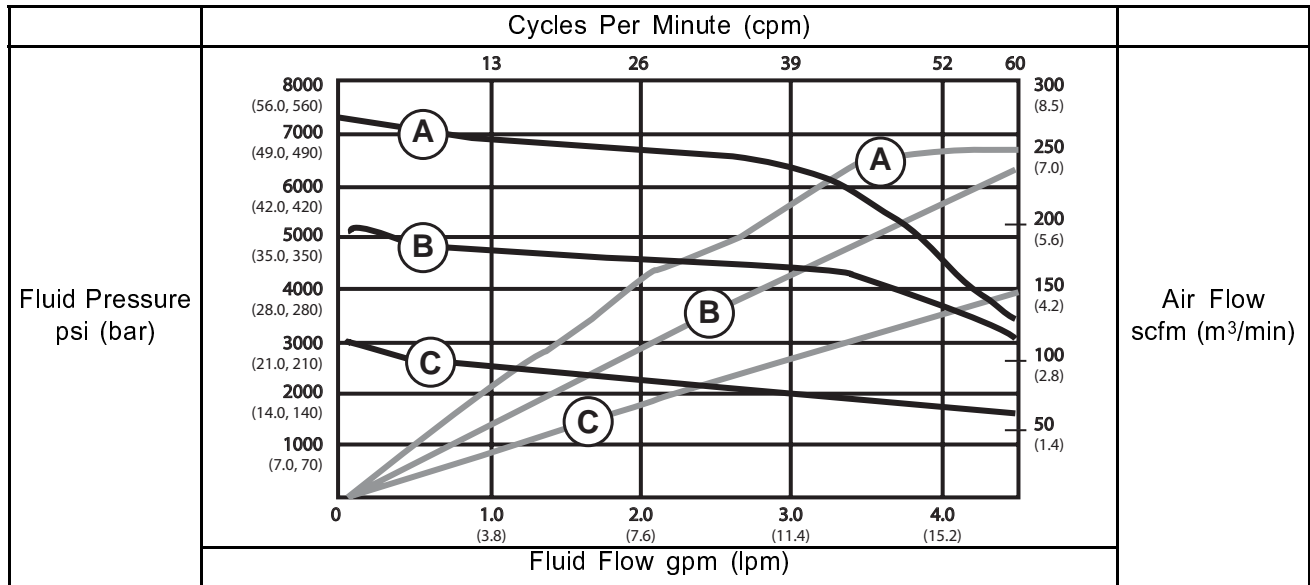

80:1

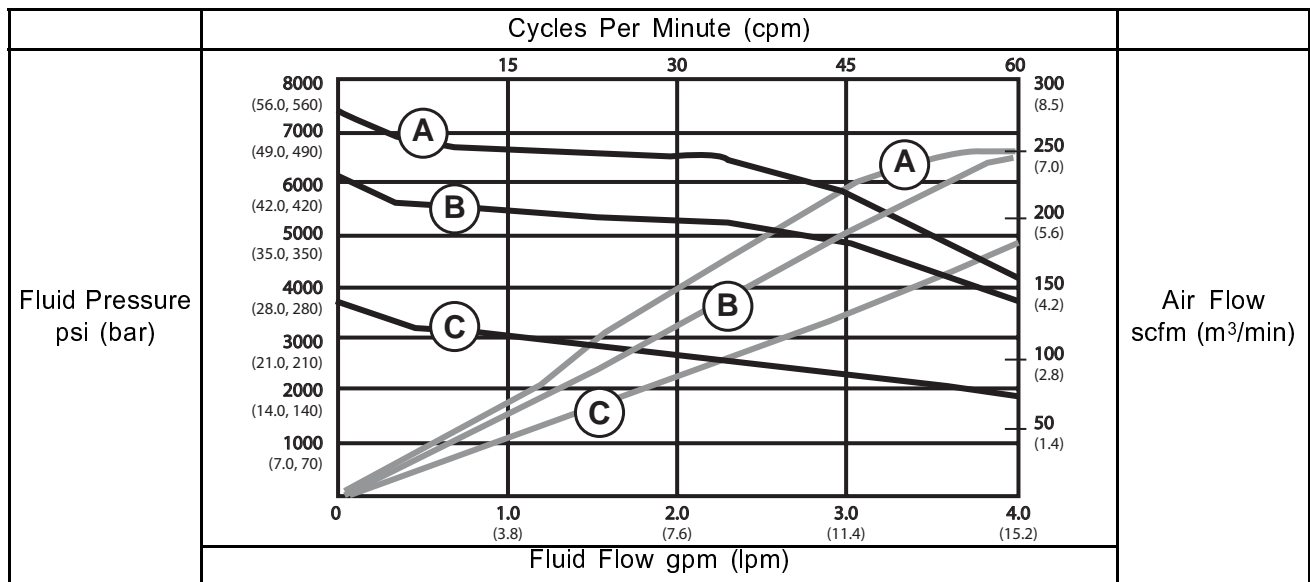

Performance Charts

Key: 95:1 Pumps Air Pressure

B	75 psi (517 kPa, 5.2 bar)
C	40 psi (280 kPa, 2.8 bar)

95:1

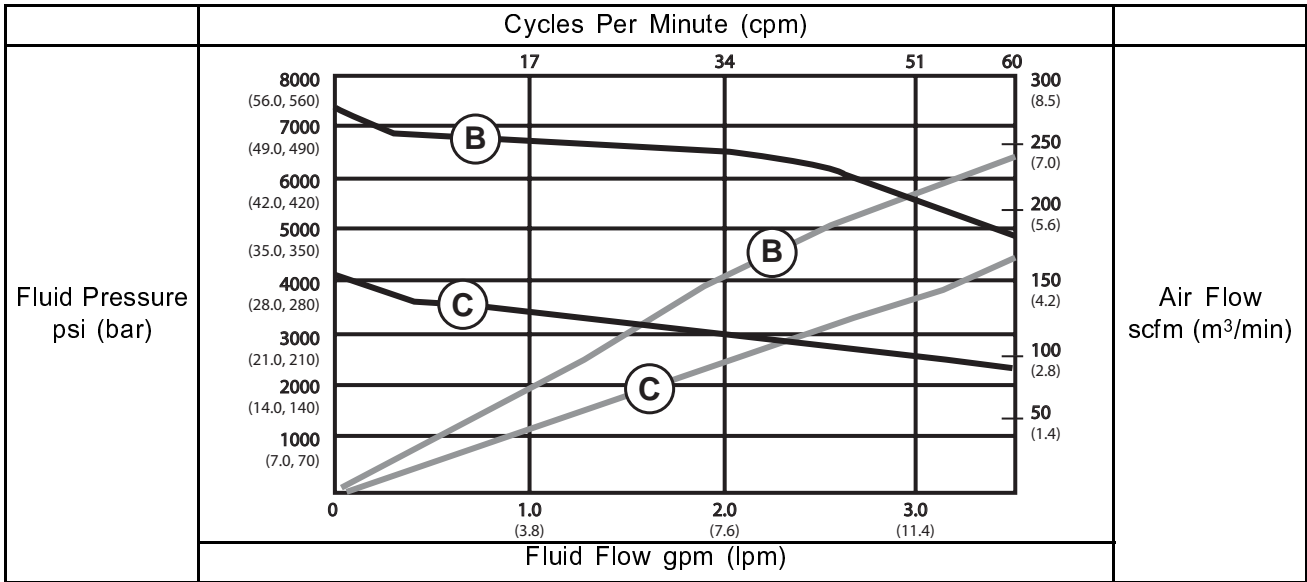

Technical Specifications

Xtreme XL Spray Packages		
	U.S.	Metric
Maximum air inlet pressure to sprayer	150 psi	1 MPa, 10.3 bar
Stroke length (nominal)	4.75 in.	
Maximum pump speed (Do not exceed maximum recommended speed of fluid pump, to prevent premature pump wear)	60 cycles per minute	
Sound Data	See Xtreme XL Motor manual for sound data.	
Air Inlet Size	1 in. npt(f)	
Wetted Parts	Carbon steel; ally steel; 304, 440 and 17-4 PH grades of stainless steel; zinc and nickel plating; ductile iron; tungsten carbide; PTFE; leather	
Fluid Inlet Size		
All Xtreme Lower Pumps	1 1/4 npt(m)	
Dura-Flo Lower Pumps	2 in. npt(f)	
Fluid Outlet Size (Number of Outlets)		
Xtreme Lower Pumps With Built-In Filters (2)	1/2 in. npt(f)	
Xtreme Lower Pumps Without Filters (1)	1 in. npt(f)	
Dura-Flo Lower Pumps (1)	3/4 npt(m)	
Maximum Air Operating Pressure		
XL45	100 psi	0.7 MPa, 7 bar
XL70	100 psi	0.7 MPa, 7 bar
XL80	88 psi	0.6 MPa, 6.1 bar
XL95	76 psi	0.52 MPa, 5.2 bar
Maximum Fluid Working Pressure		
XL45	4500 psi	31 MPa, 310 bar
XL70	7100 psi	48.9 MPa, 489 bar
XL80	7250 psi	50 MPa, 500 bar
XL95	7250 psi	50 MPa, 500 bar
Weight		
XL70, XL80, XL90	340 lbs.	154.2 kg
XL45	341 lbs.	154.7 kg

Graco Standard Warranty

Graco warrants all equipment referenced in this document which is manufactured by Graco and bearing its name to be free from defects in material and workmanship on the date of sale to the original purchaser for use. With the exception of any special, extended, or limited warranty published by Graco, Graco will, for a period of twelve months from the date of sale, repair or replace any part of the equipment determined by Graco to be defective. This warranty applies only when the equipment is installed, operated and maintained in accordance with Graco's written recommendations.

This warranty does not cover, and Graco shall not be liable for general wear and tear, or any malfunction, damage or wear caused by faulty installation, misapplication, abrasion, corrosion, inadequate or improper maintenance, negligence, accident, tampering, or substitution of non-Graco component parts. Nor shall Graco be liable for malfunction, damage or wear caused by the incompatibility of Graco equipment with structures, accessories, equipment or materials not supplied by Graco, or the improper design, manufacture, installation, operation or maintenance of structures, accessories, equipment or materials not supplied by Graco.

This warranty is conditioned upon the prepaid return of the equipment claimed to be defective to an authorized Graco distributor for verification of the claimed defect. If the claimed defect is verified, Graco will repair or replace free of charge any defective parts. The equipment will be returned to the original purchaser transportation prepaid. If inspection of the equipment does not disclose any defect in material or workmanship, repairs will be made at a reasonable charge, which charges may include the costs of parts, labor, and transportation.

THIS WARRANTY IS EXCLUSIVE, AND IS IN LIEU OF ANY OTHER WARRANTIES, EXPRESS OR IMPLIED, INCLUDING BUT NOT LIMITED TO WARRANTY OF MERCHANTABILITY OR WARRANTY OF FITNESS FOR A PARTICULAR PURPOSE.

Graco's sole obligation and buyer's sole remedy for any breach of warranty shall be as set forth above. The buyer agrees that no other remedy (including, but not limited to, incidental or consequential damages for lost profits, lost sales, injury to person or property, or any other incidental or consequential loss) shall be available. Any action for breach of warranty must be brought within two (2) years of the date of sale.

GRACO MAKES NO WARRANTY, AND DISCLAIMS ALL IMPLIED WARRANTIES OF MERCHANTABILITY AND FITNESS FOR A PARTICULAR PURPOSE, IN CONNECTION WITH ACCESSORIES, EQUIPMENT, MATERIALS OR COMPONENTS SOLD BUT NOT MANUFACTURED BY GRACO. These items sold, but not manufactured by Graco (such as electric motors, switches, hose, etc.), are subject to the warranty, if any, of their manufacturer. Graco will provide purchaser with reasonable assistance in making any claim for breach of these warranties.

In no event will Graco be liable for indirect, incidental, special or consequential damages resulting from Graco supplying equipment hereunder, or the furnishing, performance, or use of any products or other goods sold hereto, whether due to a breach of contract, breach of warranty, the negligence of Graco, or otherwise.

FOR GRACO CANADA CUSTOMERS

The Parties acknowledge that they have required that the present document, as well as all documents, notices and legal proceedings entered into, given or instituted pursuant hereto or relating directly or indirectly hereto, be drawn up in English. Les parties reconnaissent avoir convenu que la rédaction du présente document sera en Anglais, ainsi que tous documents, avis et procédures judiciaires exécutés, donnés ou intentés, à la suite de ou en rapport, directement ou indirectement, avec les procédures concernées.

Graco Information

For the latest information about Graco products, visit www.graco.com.

For patent information, see www.graco.com/patents.

To place an order, contact your Graco Distributor or call to identify the nearest distributor.

Phone: 612-623-6921 or Toll Free: 1-800-328-0211 Fax: 612-378-3505

All written and visual data contained in this document reflects the latest product information available at the time of publication.

Graco reserves the right to make changes at any time without notice.

Original Instructions. This manual contains English. MM 334645

Graco Headquarters: Minneapolis

International Offices: Belgium, China, Japan, Korea

GRACO INC. AND SUBSIDIARIES • P.O. BOX 1441 • MINNEAPOLIS MN 55440-1441 • USA

Copyright 2015, Graco Inc. All Graco manufacturing locations are registered to ISO 9001.

www.graco.com

Revision B, May 2015