



SPRINKLER EVAPORATOR AGITATOR - 5 GALLON (20 LITER) CONTAINER



Powered by **ALLREDI**.

PART NUMBERS AND SCHEMATICS GUIDE

Company Profile

Allredi was formed in the early 2020, when two of the largest distributors in the blasting, coating, safety, and environmental industry, APE Companies and Marco Group International, joined forces. While the qualities both companies are known for have not changed, a lot about our business is new. New abilities. New agilities. New ways to help you win. This calls for a new name, Allredi.

This name exemplifies what we have become. It is completely oriented to the needs of our customers. To your needs. It says that when you call us for anything – products, service, expert advice, anything – you can consider it done. Or even better, Allredi done.

We are your right-now supplier. From skills to SKUs, we deliver the goods fast. So you can be more agile every minute, every day. This is who we are. This is what our new name means. Go ahead and expect excellence, because we're bringing it.

Our Mission and Vision

To be the industry's preferred partner in surface preparation solutions through unrivaled technical expertise, customer experience, product availability, and tailored service offerings.

The Allredi Difference

- **Industry Experience** – With Allredi on your team, you have access to expertise which can only come from decades of industry leadership. We have organized our engineering department, production specialists, customer operations, and safety support into a "Center of Competence." As an Allredi customer, you have access to hundreds of years of cumulative experience related to your operations.
- **Manufacturing Excellence** – Allredi is a U.S. based manufacturer of equipment for the Surface Preparation and Protective Coatings industries. Allredi's engineers benchmark the industry to ensure that we design and manufacture superior products that set the "Gold Standard" for performance, safety, and quality.
- **Legendary Customer Service** – Allredi's legendary customer service team is staffed by friendly, highly-trained individuals who are focused on providing the highest level of product support, order accuracy, and customer satisfaction.
- **Product Availability** – We stock over 10,000 SKU's and have over 45 shipping locations to serve North American and International markets for all major brands of blasting, coating, environmental, and safety equipment. Allredi is your right-now supplier, so you can keep your projects moving. From our foundation of strong relationships, we have built a nationwide network that puts vast inventory and ready service close to our customers. We provide advanced expertise, and we deliver the goods fast – so you can easily access the products and services you need to me more agile every minute, every day.
- **Technology Leadership** – Our website provides: Operator's Manuals, Part Numbers and Schematics Guides, SDS information, and key product features and specifications, providing access to information 24/7.

TABLE OF CONTENTS

| | |
|---|----------|
| Part Numbers | 4 |
| Part Numbers And Schematics Guide | 6 |
| Marco® Elevator Agitator – 5 Gallon (20 Liter) Container | 6 |
| Filter/Lubricator Assembly | 8 |
| Optional Accessories | 9 |

PART NUMBERS

| MARCO® ELEVATOR AGITATOR – 5 GALLON (20 LITER) CONTAINER | | | | | | |
|---|------------------------|------------------------------|--------------------------|-----------------------------|---|--------------|
| Part Numbers | Air Motor Power | 15:1 Mixer Gear Drive | Filter/Lubricator | 5 Gallon Mixer Blade | Air Cylinder | Frame |
| 20100998 | 1.25 HP | X | X | X | 3-1/4" x 20" Double Acting Piston | Steel |

PART NUMBERS



PART NUMBERS AND SCHEMATICS GUIDE

Marco® Elevator Agitator – 5 Gallon (20 Liter) Container

| Item # | Part # | Description | Item # | Part # | Description |
|---------------|-------------------|---|--------|----------|--|
| Fig. 1 | | | 28 | 20101236 | 10-32 Locknut <i>(Four Required)</i> |
| — | 20100998 | Marco® Elevator Agitator – 5 Gallon (20 Liter) Container | 29 | 20101009 | Bucket Clamp |
| 1 | 20100827 | 15:1 Mixer Gear Drive | 30 | 20101023 | Draw Pull Latch |
| 2 | 20101193 | 3/8" NPT Needle Valve | 31 | 20101101 | 2" Stainless Steel Hinge |
| 3 | 20100843 | 1" To 1" Shaft Coupling | — | 1091130 | Hazard Identification Label |
| 4 | 20101264 | Screw | — | 1091135 | Hazard Identification Label |
| 5 | 20101019 | 5 Gallon Mixer Blade | — | 1091017 | Hazard Identification Tag |
| 6 | 1006067 | 10" Wheel | — | 209V515 | Operator's Manual – AM Series Lubricated Air Motors |
| 7 | 1006211 | Wheel Clip | — | 205M071 | Features & Specifications Guide – Marco® Elevator Agitator – 5 Gallon (20 Liter) Container |
| 8 | 20101046 | Cylinder 3-1/4" x 20" Double Acting Piston | — | 206M071 | Part Numbers & Schematics Guide – Marco® Elevator Agitator – 5 Gallon (20 Liter) Container |
| 9 | 10AH038 | Air Hose 3/8" | — | 10901071 | Operator's Manual – Marco® Elevator Agitator – 5 Gallon (20 Liter) Container |
| 10 | 2080020 | 3/8" Air Fluid Hose Fitting <i>(Two Required)</i> | | | |
| 11 | 20101044 | 4-Way 1/4 NPT Rotary Valve | | | |
| 12 | 10104603 | 1/2-13 x 1-1/4" Bolt – Grade 5 – Zinc <i>(Four Required)</i> | | | |
| 13 | 20101194 | 1/4" NPT Speed Control Muffler | | | |
| 14 | 20100540 | Jam Nut 3/4-16 UNF | | | |
| 15 | 10100596 | 3/4" Lock Washer | | | |
| 16 | 20100148 | 1" I.D. x 1-1/2" O.D. 10 Gage Washer | | | |
| 17 | 20PFBA31095614 | 1/4" Tube x 1/4" NPT 90° Fitting | | | |
| 18 | 20SUTR10805CLT500 | 1/4" Clear Tubing | | | |
| 19 | 20PFBA31755614 | 1/4" Tube x 1/4" NPT Straight Fitting | | | |
| 20 | 20PFHA24SA0604 | 1/4" x 3/8" Hex Nipple | | | |
| 21 | 20BK350401 | Air Motor Muffler Assembly | | | |
| 22 | 20100661 | 5/16-18 x 1-3/4" Grade 8 Hex Bolt | | | |
| 23 | 10L805003 | 5/16" Flat Washer – Zinc | | | |
| 24 | 20100900 | 5/16-18 Nylon Locknut | | | |
| 25 | 10100675 | 1/2" Lock Washer <i>(Four Required)</i> | | | |
| 26 | 20PFHA24SB0804 | 1/2" M x 1/4" (F) Bushing | | | |
| 27 | 20101235 | 10-32 x 1-3/4" SHCS <i>(Four Required)</i> | | | |

PART NUMBERS AND SCHEMATICS GUIDE

Figure 1: Marco® Elevator Agitator – 5 Gallon (20 Liter) Container

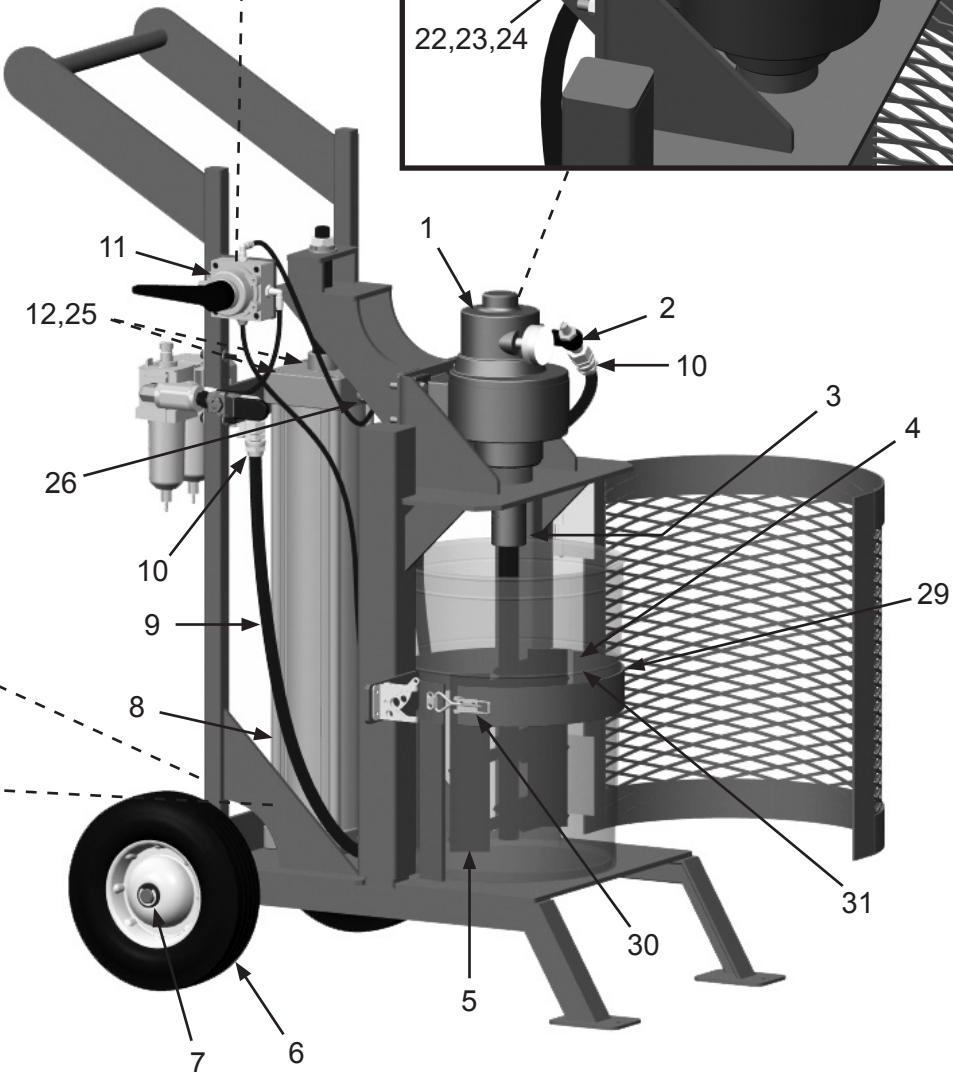
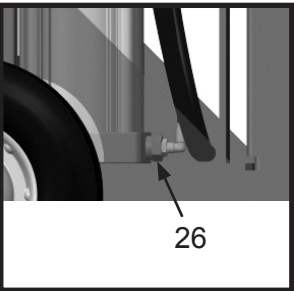
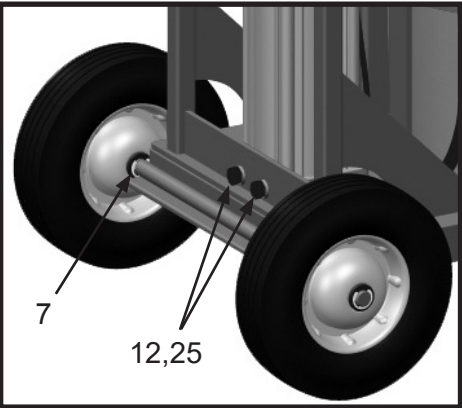
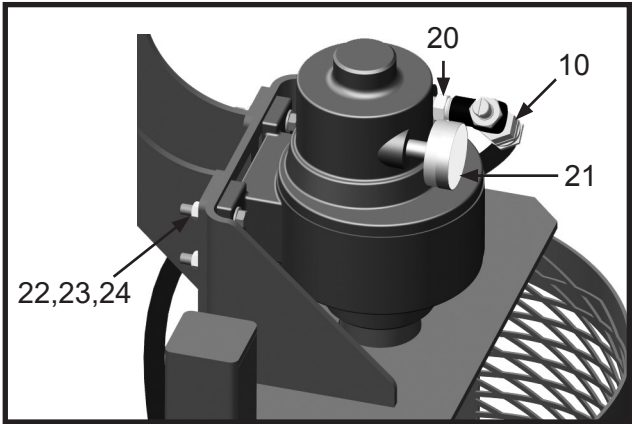
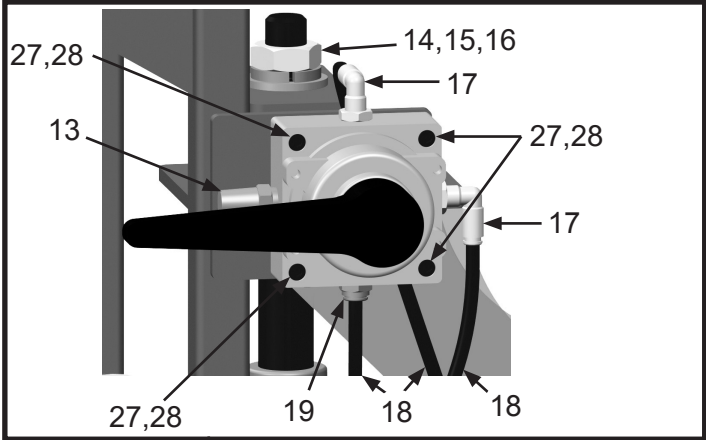

PART NUMBERS AND SCHEMATICS GUIDE

Figure 2: Filter/Lubricator Assembly

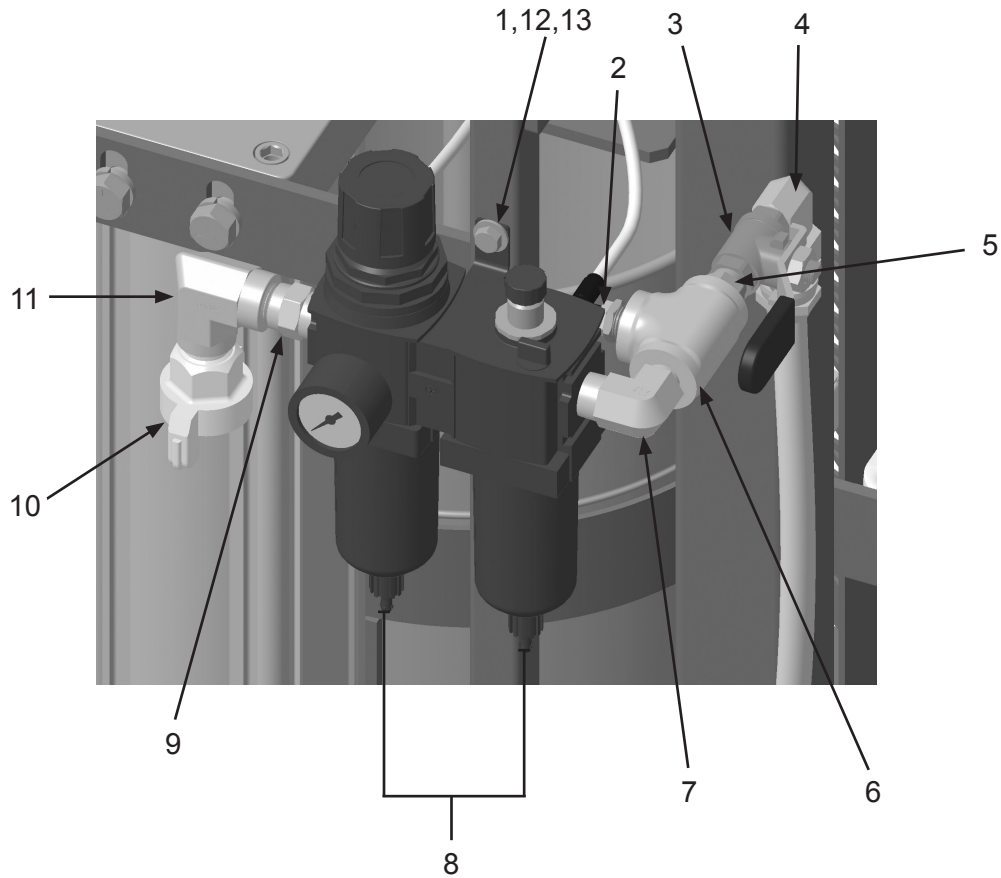



| Item # | Part # | Description |
|---------------|----------------|--|
| Fig. 2 | | |
| 1 | 1019044 | 1/4-20 x 1-3/4" Zinc Bolt (<i>Two Required</i>) |
| 2 | 20PFHA24SB0604 | 3/8" x 1/4" Reducing Bushing |
| 3 | 1080060 | 3/8" NPT Full Port Brass Ball Valve |
| 4 | 20PFHA25UA0606 | 3/8" Male 90° Elbow |
| 5 | 20PFHA24SA0606 | 3/8" Hex Nipple |
| 6 | 20PFHA25VJ06 | 3/8" Female Tee |
| 7 | 20PFHA25UA0806 | 1/2" x 3/8" MNPT 90° Elbow |
| 8 | 10101232 | 3/8" NPT Filter Regulator, Lubricator |
| 9 | 20PFHA24SA0808 | 1/2" x 1/2" Hex Nipple |
| 10 | 10ME122 | 1/2" NPT Male 2 Lug Coupling |
| 11 | 20PFHA25UJ08 | 1/2" Female Elbow |
| 12 | 1012323 | 1/4-20 Zinc Lock Nut with Nylon Insert (<i>Two Required</i>) |
| 13 | 1014017 | 1/4" Flat Washer (<i>Two Required</i>) |
| — | 20101278 | 25 Micron Filter Element |
| — | 20101279 | Semi-Auto Drain Replacement Bowl |
| — | 20101280 | Oil Drip Dome |
| — | 10105291 | Air Tool Oil – 4 oz. |
| — | 1070517 | Marvel Pneumatic Tool Oil – 32 oz. |

OPTIONAL ACCESSORIES

| | | 3/4" I.D. X 1-1/4" O.D. AIR HOSE | | | | |
|--|---------------------|---|-------------------------|---------------|------------------|------------------|
|  | Part Numbers | Working Pressure | Hose Cover Color | Length | Hose I.D. | Hose O.D. |
| | 10AH034 | 200 PSI | Red | Per Ft. | 3/4" | 1-1/4" |

| | | 3/4" I.D. X 1-1/4" O.D. AIR HOSE WITH COUPLINGS INSTALLED | | | | | |
|---|---------------------|--|-------------------------|---------------|------------------|------------------|------------------|
|  | Part Numbers | Working Pressure | Hose Cover Color | Length | Hose I.D. | Hose O.D. | Couplings |
| | 10AH034AC | 200 PSI | Red | 50 Ft. | 3/4" | 1-1/4" | 2-Lug Crimped On |

| | | MALE HOSE END COUPLING AND GASKET FOR 3/4" I.D. AIR HOSE | | | | | |
|---|---------------------|---|-----------------|-----------------------|----------------------|--------------------|--------------------|
|  | Part Numbers | Hose I.D. | Material | Coupling Style | GASKET | | |
| | | | | | Rubber Gasket | Gasket I.D. | Gasket O.D. |
| | 10HE1 | 3/4" | Plated Iron | 2-Lug | 10UG2 | 3/4" | 1-3/8" |

| | | BOSS® CLAMP FOR 3/4" I.D. AIR HOSE | | |
|---|---------------------|---|------------------------|-----------------|
|  | Part Numbers | Hose I.D. | Hose O.D. Range | Material |
| | 10A9 | 3/4" | 1-8/64" – 1-20/64" | Plated Steel |

OPTIONAL ACCESSORIES

| | | 1" I.D. X 1-1/2" O.D. AIR HOSE | | | | |
|--|----------|--------------------------------|------------------|---------|-----------|-----------|
| Part Numbers | | Hose Cover Color | Working Pressure | Length | Hose I.D. | Hose O.D. |
|  | 10AH100B | Black | 200 PSI | Per Ft. | 1" | 1-1/2" |
| | 10AH100 | Red | 200 PSI | Per Ft. | 1" | 1-1/2" |

| | | 1" I.D. X 1-1/2" O.D. AIR HOSE WITH COUPLINGS INSTALLED | | | | | |
|---|-----------|---|------------------|--------|-----------|-----------|------------------|
| Part Numbers | | Working Pressure | Hose Cover Color | Length | Hose I.D. | Hose O.D. | Couplings |
|  | 10AH100AC | 200 PSI | Red | 50 Ft. | 1" | 1-1/2" | 2-Lug Crimped On |

| | | MALE HOSE END COUPLING AND GASKET FOR 1" I.D. AIR HOSE | | | | | |
|---|-------|--|-------------|----------------|---------------|-------------|-------------|
| Part Numbers | | Hose I.D. | Material | Coupling Style | GASKET | | |
| | | | | | Rubber Gasket | Gasket I.D. | Gasket O.D. |
|  | 10HE2 | 1" | Plated Iron | 2-Lug | 10UG2 | 3/4" | 1-3/8" |

| | | HAMMER-LOCK GROUND JOINT FITTING FOR 1" I.D. AIR HOSE | |
|--|----------|---|--------------|
| Part Numbers | | Hose I.D. | Material |
|  | 10DXGF36 | 1" | Plated Steel |

| | | BOSS® CLAMP FOR 1" I.D. AIR HOSE | | |
|---|-------|----------------------------------|---------------------|--------------|
| Part Numbers | | Hose I.D. | Hose O.D. Range | Material |
|  | 10A14 | 1" | 1-32/64" – 1-52/64" | Plated Steel |

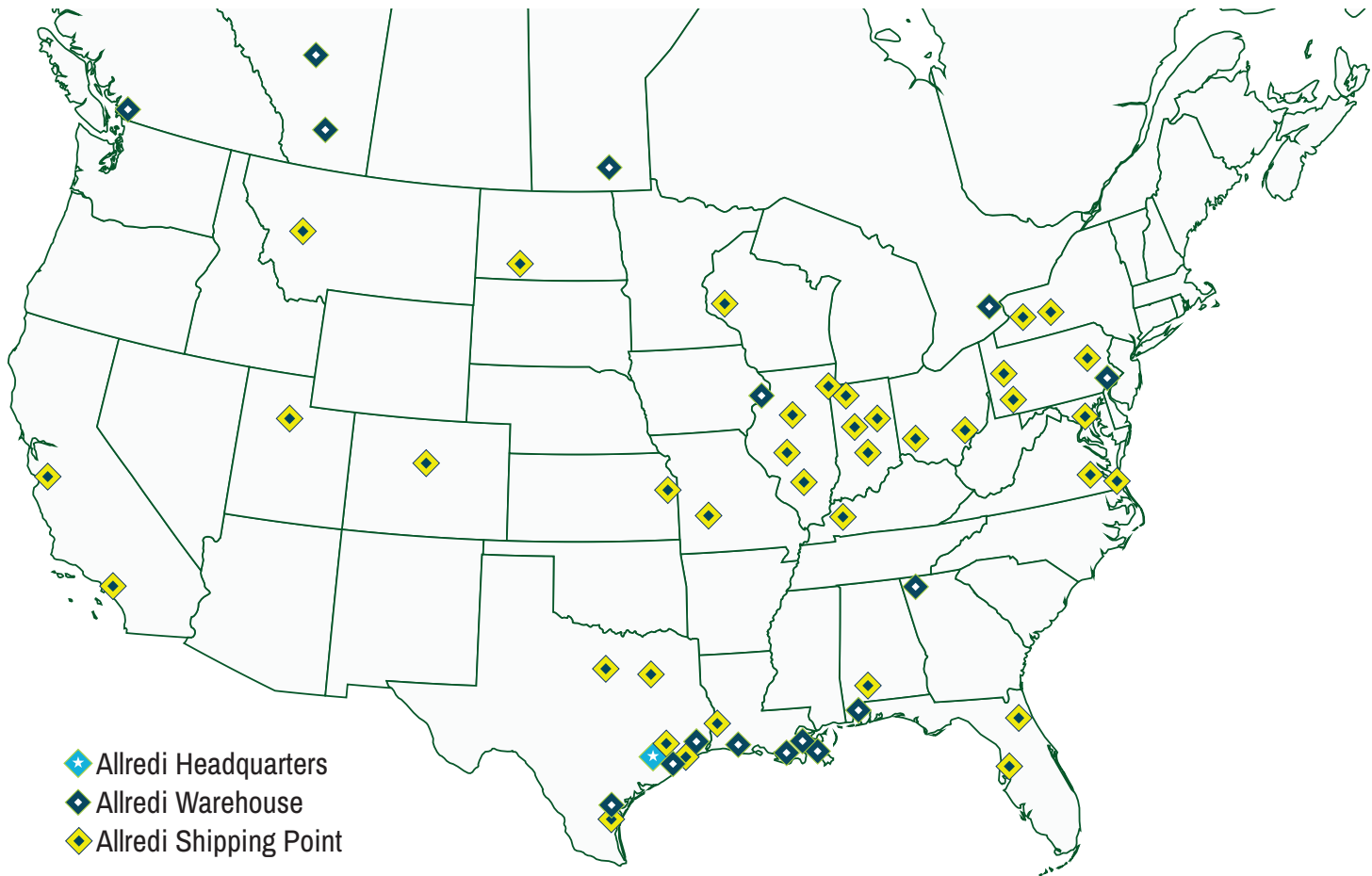

ALLREDI THERE

Serving these industries: Bridge, Pipeline, Tank & Tower, Concrete Services, Rail, Shipyard & Marine, Pools & Fountains, and Foundry

UNITED STATES

Pasadena, TX (*Headquarters*)
844.361.7038

Beaumont, TX
409.722.1284

Bristol, PA
215.826.8080

Corpus Christi, TX
361.887.2038

Davenport, IA
563.324.2519

Deer Park, TX
(*Service & Rental Location*)
281.930.0905

Duluth, GA
800.535.4564

Gonzales, LA
225.647.7575

Harvey, LA
504.367.8090

Houma, LA
985.580.4273

Lafayette, LA
337.267.1440

Theodore, AL
251.338.7525

CANADA

Calgary, Alberta
403.279.1924

Coquitlam, BC
604.464.6979

Edmonton, Alberta
780.468.2588 (Manus)
780.425.5510 (Mod-U-Blast)

Hamilton, Ontario
905.527.6000 / 888.794.5665

Mississauga, Ontario
905.890.5837

Winnipeg, Manitoba
204.256.3324

WWW.ALLREDI-US.COM / 800.252.7848

WWW.ALLREDI-CA.COM / 800.661.3842

Allredi™ and Marco® are registered trademarks of Allredi, LLC.
Mod-U-Blast® is a registered trademark of Allredi Blast & Abrasives Canada, Inc.
All other brand names or marks are used for identification purposes and are trademarks of their respective owners.

ALLREDI™

Literature #206M071_9/26/2024