



MARCO® 3.0 CU. FT. C-SERIES ABRASIVE BLASTING POT



Powered by **ALLREDI**.

PART NUMBERS AND SCHEMATICS GUIDE

Company Profile

Allredi was formed in the early 2020, when two of the largest distributors in the blasting, coating, safety, and environmental industry, APE Companies and Marco Group International, joined forces. While the qualities both companies are known for have not changed, a lot about our business is new. New abilities. New agilities. New ways to help you win. This calls for a new name, Allredi.

This name exemplifies what we have become. It is completely oriented to the needs of our customers. To your needs. It says that when you call us for anything – products, service, expert advice, anything – you can consider it done. Or even better, Allredi done.

We are your right-now supplier. From skills to SKUs, we deliver the goods fast. So you can be more agile every minute, every day. This is who we are. This is what our new name means. Go ahead and expect excellence, because we're bringing it.

Our Mission and Vision

To be the industry's preferred partner in surface preparation solutions through unrivaled technical expertise, customer experience, product availability, and tailored service offerings.

The Allredi Difference

- **Industry Experience** – With Allredi on your team, you have access to expertise which can only come from decades of industry leadership. We have organized our engineering department, production specialists, customer operations, and safety support into a "Center of Competence." As an Allredi customer, you have access to hundreds of years of cumulative experience related to your operations.
- **Manufacturing Excellence** – Allredi is a U.S. based manufacturer of equipment for the Surface Preparation and Protective Coatings industries. Allredi's engineers benchmark the industry to ensure that we design and manufacture superior products that set the "Gold Standard" for performance, safety, and quality.
- **Legendary Customer Service** – Allredi's legendary customer service team is staffed by friendly, highly-trained individuals who are focused on providing the highest level of product support, order accuracy, and customer satisfaction.
- **Product Availability** – We stock over 10,000 SKU's and have over 45 shipping locations to serve North American and International markets for all major brands of blasting, coating, environmental, and safety equipment. Allredi is your right-now supplier, so you can keep your projects moving. From our foundation of strong relationships, we have built a nationwide network that puts vast inventory and ready service close to our customers. We provide advanced expertise, and we deliver the goods fast – so you can easily access the products and services you need to me more agile every minute, every day.
- **Technology Leadership** – Our website provides: Operator's Manuals, Part Numbers and Schematics Guides, SDS information, and key product features and specifications, providing access to information 24/7.

TABLE OF CONTENTS

CONTENTS

Part Numbers	4
Part Numbers and Schematics	5
Inspection Door Assembly	5
Pop-up Valve Assembly	5
Marco® 3.0 Cu. Ft. C-Series Abrasive Blasting Pot – Pneumatic	6
Marco® 3.0 Cu. Ft. C-Series Abrasive Blasting Pot – Electric	8
Pusher Line Assembly	10
Exhaust Muffler Assembly	11
Marco® 125P Remote Control System	12
1-1/2" Inlet Valve	14
1" Outlet Valve	15
Abrasive Trap	16
120-Volt AC to 12-Volt AC Power Converter	17
12-Volt DC Marco® 125E Remote Control System ..	18
12-Volt DC 190 Electric Control Assembly	20
12-Volt DC 190 Electric Solenoid	21
120-Volt AC Marco® 125E Remote Control System .	22
12-Volt AC 190 Electric Control Assembly	24
12-Volt AC 190 Electric Solenoid	25
Marco® Regulator Abrasive Metering Valve	26
Optional Accessories	28
1-1/4" Junior Extracor Abrasive Blasting Pot Moisture Separator	28
Lid and Screen	29

PART NUMBERS

MARCO® 3.0 CU. FT. C-SERIES ABRASIVE BLASTING POT

Part Numbers	Power Source	Marco® Remote Control System	Marco® Remote Control Switch	Marco® Regulator Abrasive Metering Valve	1-1/4" Junior Extractor Abrasive Blasting Pot Moisture Separator
1003008	Pneumatic	125P	150P	X	
1003008PKA	Pneumatic	125P	150P	X	X
1003002	12-Volt DC	125E	151E	X	
1003002PKA	12-Volt DC	125E	151E	X	X
1003004	120-Volt AC	125E	151E	X	
1003004PKA	120-Volt AC	125E	151E	X	X

PART NUMBERS AND SCHEMATICS

Figure 1: Inspection Door Assembly

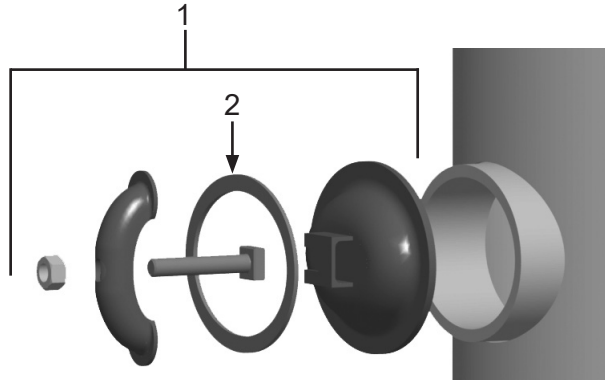

Item #	Part #	Description
Fig. 1		
1	1006200	6" x 8" Inspection Door Assembly
2	1006201	Gasket

Figure 2: Pop-up Valve Assembly

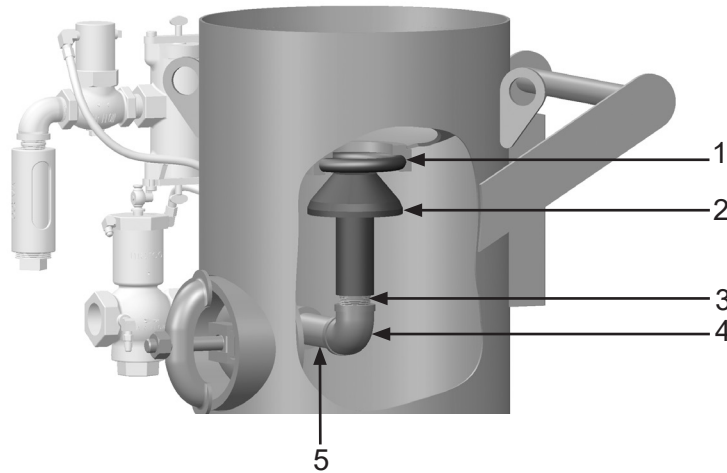

Item #	Part #	Description
Fig. 2		
1	1006050	Pop-Up Valve Seat
2	1006020	Pop-Up Valve – External Sleeve
3	1006206	1-1/4" NPT x 5" Toe Nipple
4	1006204	1-1/4" 90° Elbow
5	1011202	1-1/4" NPT x 6" Pipe Nipple

PART NUMBERS AND SCHEMATICS GUIDE

Marco® 3.0 Cu. Ft. C-Series Abrasive Blasting Pot – Pneumatic

Item #	Part #	Description
Fig. 3		
1	1012050	1" Outlet Valve (See Literature 106M014)
2	10CL18	18" Control Line
3	1011801	1" Galvanized Street Elbow
4	1011100	Abrasive Blasting Pot Muffler (See Fig. 6)
5	1012200	1-1/2" Inlet Valve (See Literature 106M014)
6	1011203	1-1/2" x 3" Galvanized Nipple (Two Required)
7	1014000	Marco® Regulator Abrasive Metering Valve (See Literature 106M021)
8	10SB1	1-1/4" Brass Tank Coupling
9	1011201	1-1/4" Galvanized Close Nipple (Two Required)
10	1011206	1-1/4" x 2-1/2" Galvanized Nipple
11	1011501	1-1/2" (M) x 1-1/4" (F) Galvanized Hex Bushing
12	1006211	3/4" Wheel Clip (Two Required) for units built after March 2021
	1006205	1" Wheel Clip (Four Required) for units built before March 2021
13	10106067	10" Wheel (Two Required) for units built after March 2021
	1006064	16" Wheel (Two Required) for units built before March 2021
14	1006312	1-1/2" I.D. Pusher Line Assembly (See Fig. 5)
15	1011603	1-1/2" Full Port Ball Valve
16	1014015	1-1/2" Galvanized Close Nipple
17	1011839	1-1/2" 90° Galvanized Street Elbow
18	1011833	1-1/4" x 1-1/2" x 1-1/2" Galvanized Pipe Tee
19	1012000	1" Abrasive Trap (See Literature 106M014)
20	1011901	1" Galvanized Square Head Pipe Plug
21	1011816	1" Galvanized Pipe Tee
22	1012151	1" Galvanized Close Nipple
—	106M071	Part Numbers & Schematics Guide – Marco® 3.0 Cu. Ft. C-Series Abrasive Blasting Pot
—	1090071	Operator's Manual – Marco® 3.0 Cu. Ft. C-Series Abrasive Blasting Pot
—	106M023	Part Numbers & Schematics Guide – Marco® 150P Remote Control Switch
—	1090023	Operator's Manual – Marco® 150P Remote Control Switch

PART NUMBERS AND SCHEMATICS GUIDE

Figure 3: Marco® 3.0 Cu. Ft. C-Series Abrasive Blasting Pot – Pneumatic

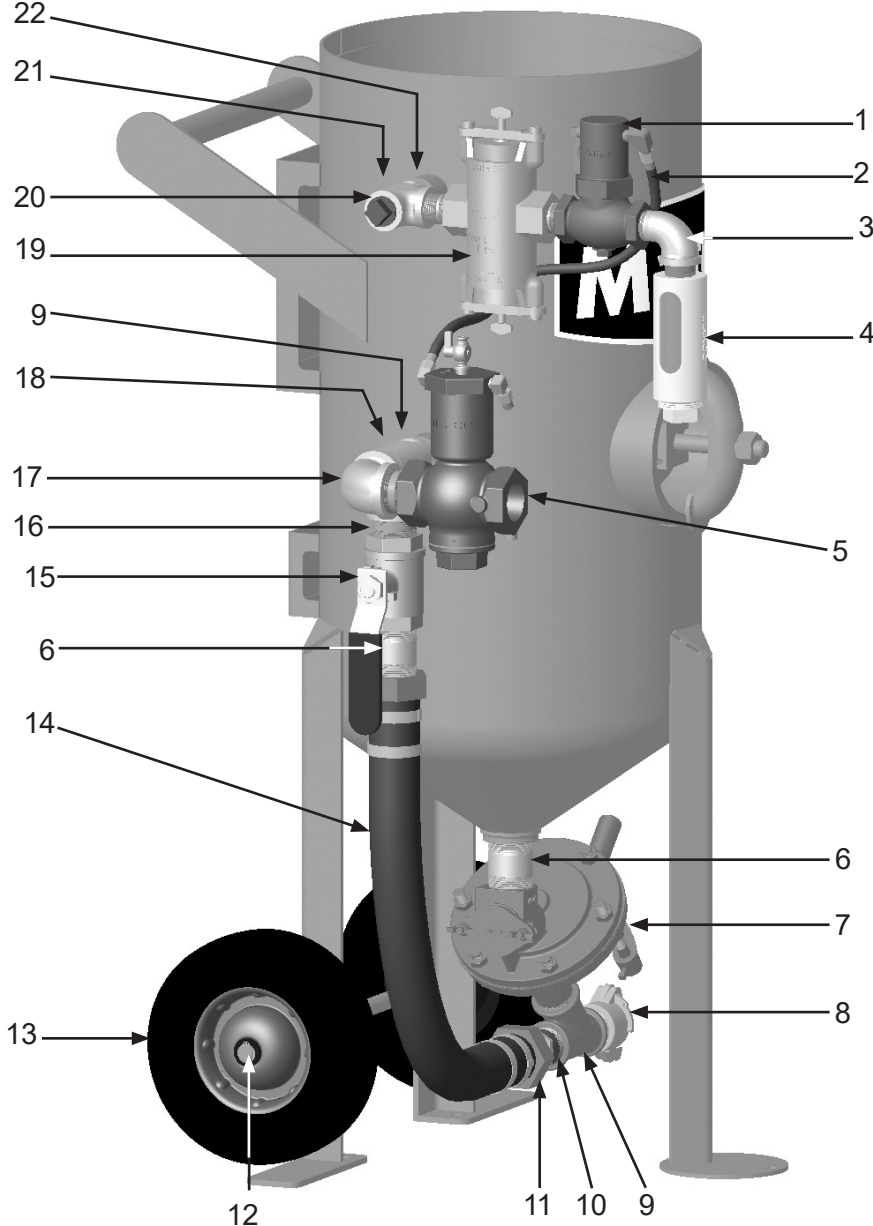

PART NUMBERS AND SCHEMATICS GUIDE

Marco® 3.0 Cu. Ft. C-Series Abrasive Blasting Pot – Electric

Item #	Part #	Description
Fig. 4		
1	1012050	1" Outlet Valve
2	10CL18	18" Control Line
3	1011801	1" Galvanized Street Elbow
4	1011100	Abrasive Blasting Pot Muffler (<i>See Fig. 6</i>)
5	10TL040	Coupled Pneumatic Control Line - 40" Twinline
6	1012200	1-1/2" Inlet Valve
7	1011203	1-1/2" x 3" Galvanized Nipple (<i>Two Required</i>)
8	1014000	Marco® Regulator Abrasive Metering Valve
9	10SB1	1-1/4" Brass Tank Coupling
10	1011201	1-1/4" Galvanized Close Nipple (<i>Two Required</i>)
11	1011206	1-1/4" x 2-1/2" Galvanized Nipple
12	1011501	1-1/2" (M) x 1-1/4" (F) Galvanized Hex Bushing
13	1006211	3/4" Wheel Clip (<i>Two Required</i>) for units built after March 2021
	1006205	1" Wheel Clip (<i>Four Required</i>) for units built before March 2021
14	10106067	10" Wheel (<i>Two Required</i>) for units built after March 2021
	1006064	16" Wheel (<i>Two Required</i>) for units built before March 2021
15	1006312	1-1/2" I.D. Pusher Line Assembly (<i>See Fig. 5</i>)
16	1011603	1-1/2" Full Port Ball Valve
17	1014015	1-1/2" Galvanized Close Nipple
18	1011839	1-1/2" 90° Galvanized Street Elbow
19	1011833	1-1/4" x 1-1/2" x 1-1/2" Galvanized Pipe Tee
20	1012000	1" Abrasive Trap
21	1019001	12-Volt DC 190 Electric Control Assembly
—	1019002	12-Volt AC 190 Electric Control Assembly
22	1011901	1" Galvanized Square Head Pipe Plug
23	1011816	1" Galvanized Pipe Tee
24	1012151	1" Galvanized Close Nipple
25	1019044	1/4-20 x 1-3/4" Zinc Bolt (<i>Two Required</i>)
26	1012323	1/4-20 Zinc Lock Nut with Nylon Insert (<i>Two Required</i>)
27	1030020	Marco® 120VAC-12VAC Converter (<i>Optional</i>)
28	1012154	1/4-20 x 1" Hex Bolt (<i>Four Required</i>)
29	1014017	1/4" Flat Washer (<i>Four Required</i>)
—	106M063	Part Numbers & Schematics Guide – Marco® 151E Remote Control Switch
—	106M071	Part Numbers & Schematics Guide – Marco® 3.0 Cu. Ft. C-Series Abrasive Blasting Pot
—	1090063	Operator's Manual – Marco® 151E Remote Control Switch
—	1090071	Operator's Manual – Marco® 3.0 Cu. Ft. C-Series Abrasive Blasting Pot

PART NUMBERS AND SCHEMATICS GUIDE

Figure 4: Marco® 3.0 Cu. Ft. C-Series Abrasive Blasting Pot – Electric

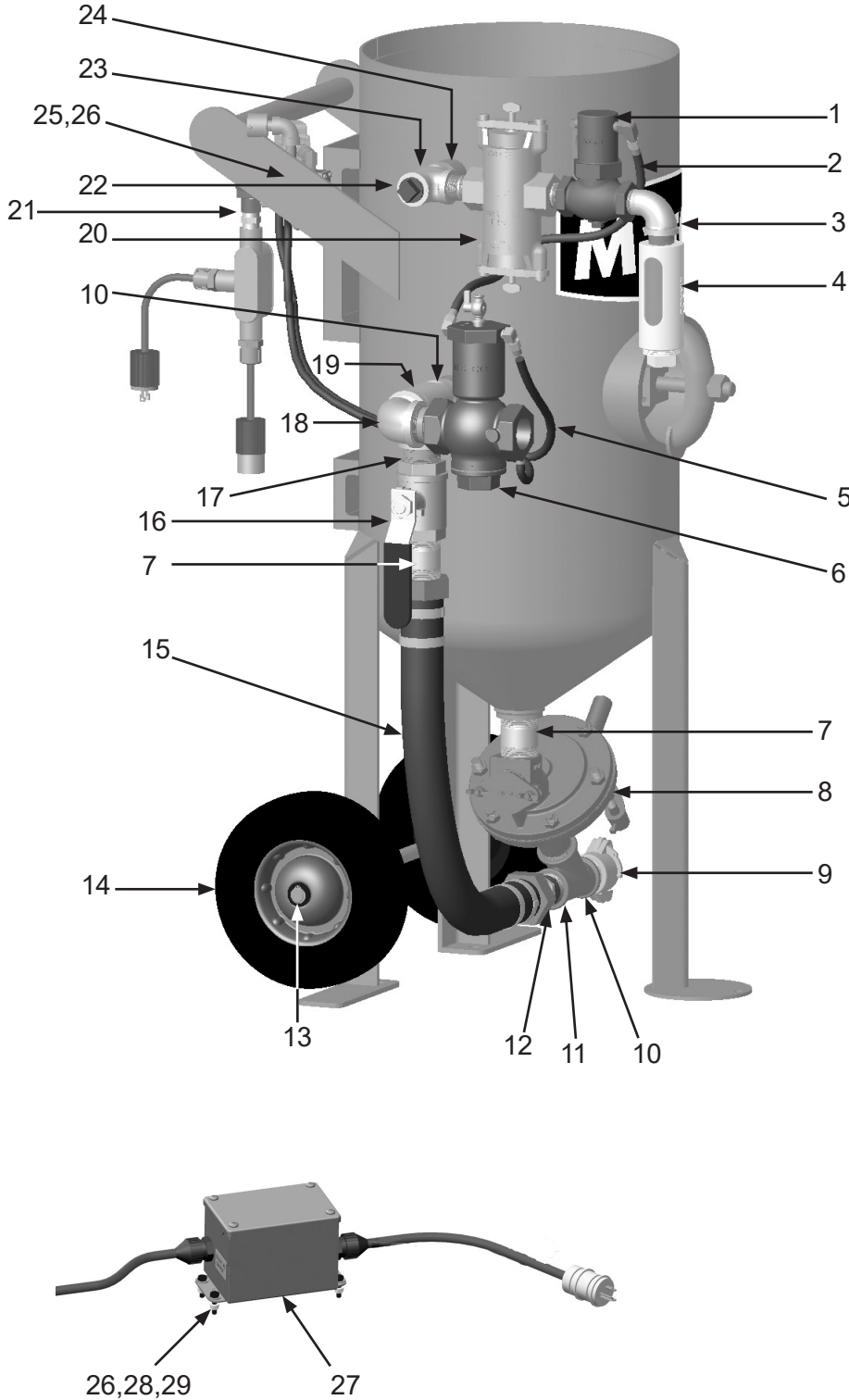

PART NUMBERS AND SCHEMATICS

Figure 5: Pusher Line Assembly

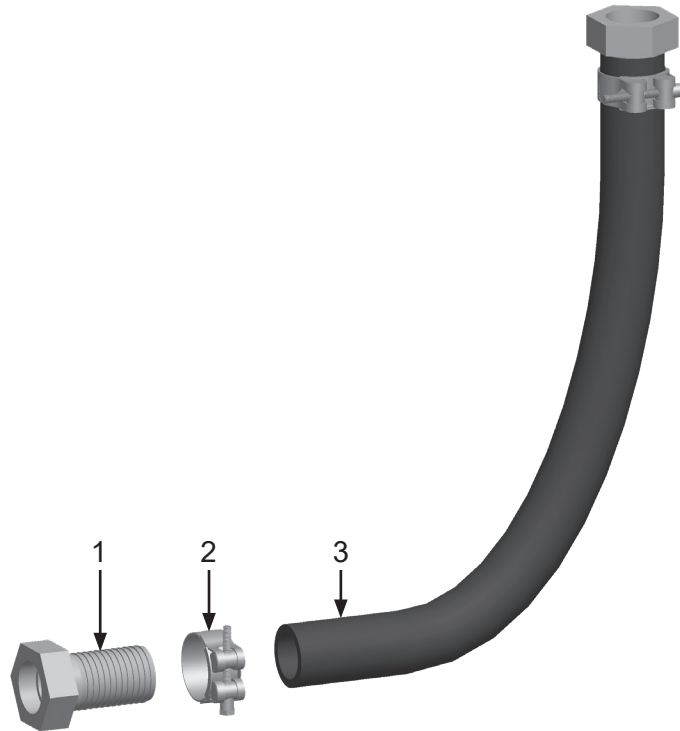

Item #	Part #	Description
—	1006312	1-1/2" I.D. Pusher Line Assembly <i>Includes Item #: 1, 2, and 3 (Quantity of Three Feet)</i>
1	10SFE4	1-1/2" Female Swivel Air Hose End <i>(Two Required)</i>
2	10103738	1-1/2" T-Bolt Hose Clamp <i>(Two Required)</i>
3	10AH112B	1-1/2" I.D. Air Hose
—	10SFE4G	Gasket for 10SFE4 Swivel Air Hose End <i>(Not Shown)</i>
—	1090059	Technical Data Sheet – Pusher Line Assemblies

PART NUMBERS AND SCHEMATICS

Figure 6: Exhaust Muffler Assembly

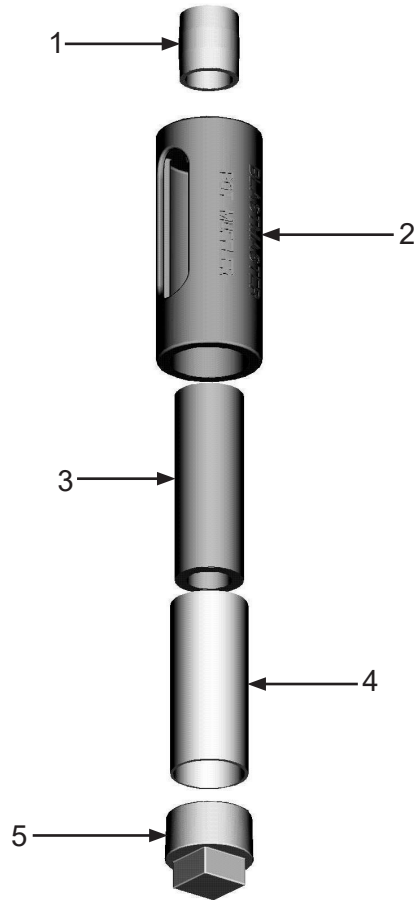

Item #	Part #	Description
Fig. 6		
—	1011100	Marco® Abrasive Blasting Pot Muffler – Complete
1	1012151	1" Close Nipple
2	1011102	Body
3	1011103	Filter Element
4	1011104	Screen
5	1011101	1-1/2" Pipe Plug
—	1011105	Marco® Abrasive Blasting Pot Muffler Service Kit <i>Includes Item #'s: 3 (Quantity of Three), 4, and 5</i>
—	105M347	Features and Specifications Guide – Marco® Abrasive Blasting Pot Mufflers
—	106M347	Part Numbers And Schematics Guide – Marco® Abrasive Blasting Pot Mufflers

PART NUMBERS AND SCHEMATICS

Marco® 125P Remote Control System

Item #	Part #	Description
Fig. 7		
—	1012500	Marco® 125P Remote Control System – Complete
1	1012000	Abrasive Trap – Complete (<i>see Figure 10</i>)
2	1012050	1" Outlet Valve – Complete (<i>see Figure 9</i>)
3	10CL18	Coupled Pneumatic Control Line – 18 Inches
4	10TL5	Coupled Pneumatic Control Line – 5 Feet
5	1017001	3/16" Control Line Union (<i>Two Required</i>)
6	10TL50	Coupled Pneumatic Control Line – 50 Feet
	10TL100	Coupled Pneumatic Control Line – 100 Feet (<i>optional</i>)
7	1015000	Marco® 150P Remote Control Switch – Complete
8	1012200	1-1/2" Inlet Valve – Complete (<i>see Figure 8</i>)
—	1011501	1-1/2" NPT (M) x 1-1/4" NPT (F) Bushing (<i>Not Shown</i>)

PART NUMBERS AND SCHEMATICS

Figure 7: Marco® 125P Remote Control System

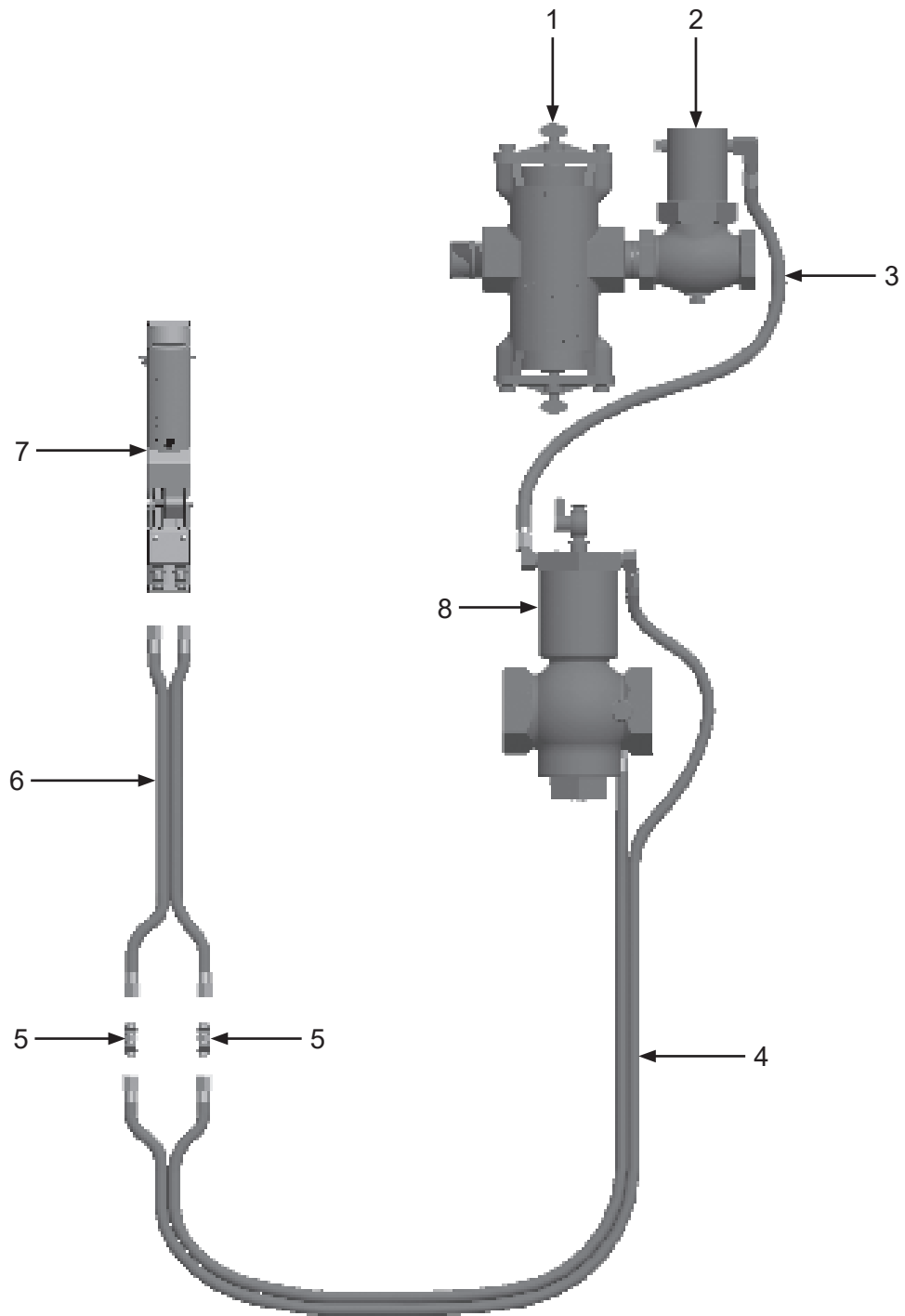

PART NUMBERS AND SCHEMATICS

Figure 8: 1-1/2" Inlet Valve

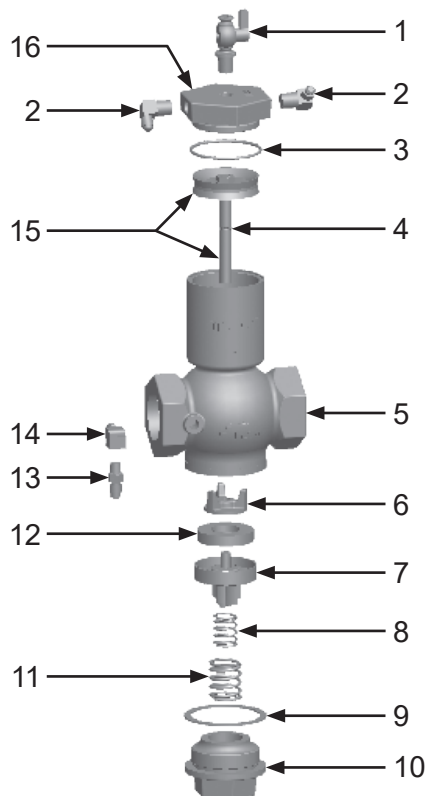

Item #	Part #	Description
Fig. 8		
—	1012200	1-1/2" Inlet Valve – Complete
1	1012101	1/4" NPT Petcock
2	1012051	1/4" NPT Brass Elbow (<i>Two Required</i>)
3	1012213	1/8" x 2-1/2" O-ring
4	1012208	1/16" x 7/16" O-ring
5	1012204	1-1/2" Body
6	1012207	1-1/2" Plug Washer Retainer
7	1012205	1-1/2" Plug
8	1012105	5/8" x 1-11/16" Inner Spring
9	1012202	1-1/2" Bottom Cap Gasket
10	1012201	1-1/2" Bottom Cap
11	1012203	7/8" x 2-1/16" Outer Spring
12	1012206	1-1/2" Plug Washer
13	1012103	1/8" Adapter with 1/16" Restrictor Port
14	1012113	1/8" Street Elbow
15	1012209	Piston and Rod Assembly
16	1012214	1-1/2" Cylinder Cap
—	1012215	1-1/2" Inlet Valve Repair Kit (Includes Item #'s: 3,4,8,9,11, and 12 (Quantity of Two))

PART NUMBERS AND SCHEMATICS

Figure 9: 1" Outlet Valve

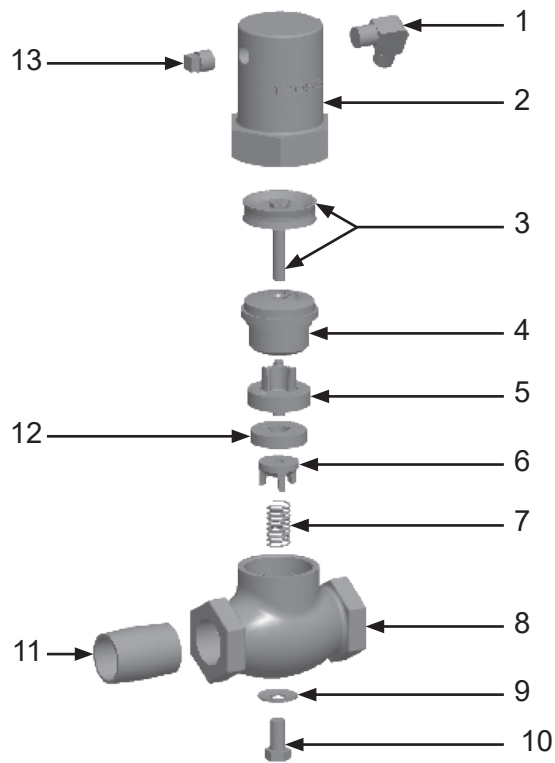

Item #	Part #	Description
Fig. 9		
—	1012050	1" Outlet Valve – Complete
1	1012051	1/4" x 1/4" Brass Elbow
2	1012053	Bonnet
3	1012054	Piston and Rod Assembly
4	1012058	Plug and Spindle Guide
5	1012059	Plug
6	1012061	Plug Washer Retainer
7	1012063	7/16" x 1-5/8" Spring
8	1012062	Body
9	1012064	3/8" Nylon Washer
10	1012065	3/8" x 3/4" Bolt
11	1012151	1" NPT Close Nipple
12	1012060	Plug Washer
13	1012052	1/4" NPT Pipe Plug
—	1012066	1" Outlet Valve Repair Kit (Includes Item #'s: 5,6,7,9,10, and 12 (Quantity of Two))

PART NUMBERS AND SCHEMATICS

Figure 10: Abrasive Trap

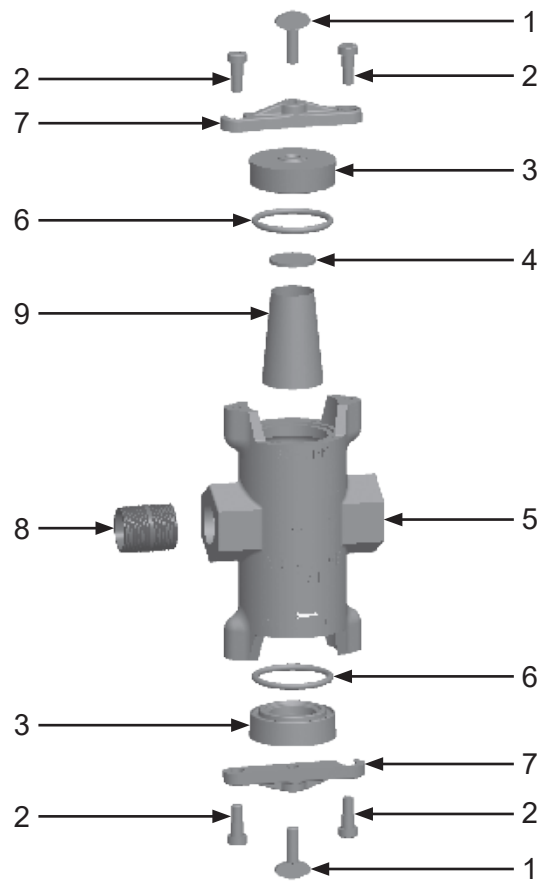

Item #	Part #	Description
Fig. 10		
—	1012000	Abrasive Trap – Complete
1	1012006	Thumb Screw (<i>Two Required</i>)
2	1012007	3/8" x 3/8" Shoulder Bolt (<i>Four Required</i>)
3	1012003	Abrasive Trap Cap (<i>Two Required</i>)
4	1012008	Abrasive Trap Screen Gasket
5	1012004	Abrasive Trap Body
6	1012002	Abrasive Trap O-ring (<i>Two Required</i>)
7	1012005	Cap Lock Bar (<i>Two Required</i>)
8	1012151	1" NPT Close Nipple
9	1012001	Abrasive Trap Screen
—	1012009	Abrasive Trap Repair Kit (Includes Item #'s: 4,6 (<i>Quantity of Two</i>), and 9 (<i>Quantity of Three</i>))

PART NUMBERS AND SCHEMATICS

Figure 11: 120-Volt AC to 12-Volt AC Power Converter

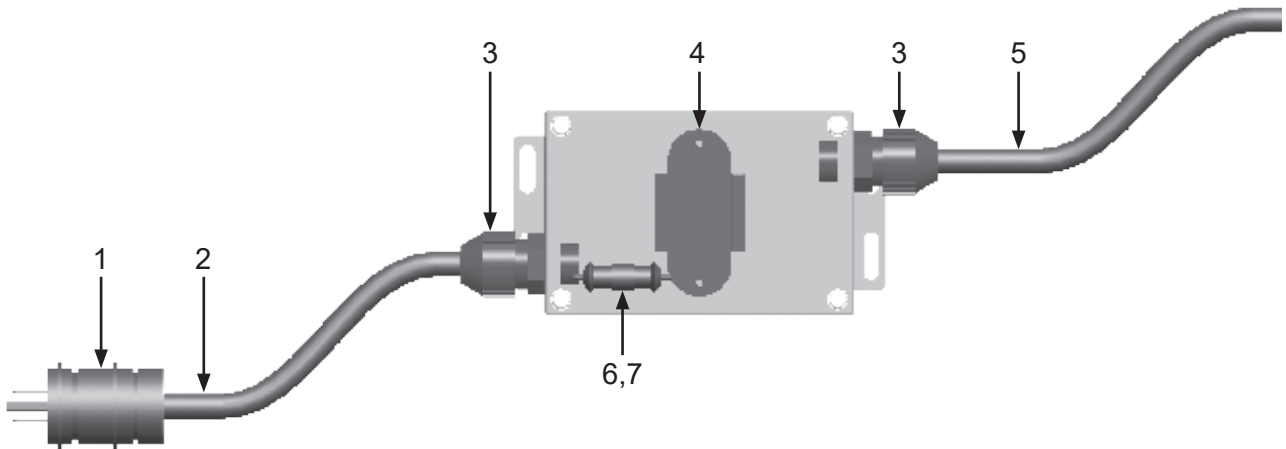

Item #	Part #	Description
Fig. 11		
—	1030020	Marco 120-Volt AC to 12-Volt AC Power Converter – Complete
1	1030026	3-prong, 120-Volt AC Plug – Male
2	1015550	14/3 SEOW Power Cord (<i>Per Foot</i>)
3	1030025	Strain Relief (<i>Two Required</i>)
4	1030022	Transformer – Marco 120-Volt AC to 12-Volt AC Power Converter
5	1030013	14/2 SEOW Power Cord (<i>Per Foot</i>)
6	1030024	2 Amp Fuse
7	1030023	In-Line Fuse Holder
—	1030021	Resistor (<i>Not Shown</i>)
—	1091063	Marco 120-Volt AC to 12-Volt AC Power Converter Hazard Identification Label
—	1091067	Power-Out Decal (<i>Not Shown</i>)
—	1092014	Power-In Decal (<i>Not Shown</i>)

PART NUMBERS AND SCHEMATICS

12-Volt DC Marco® 125E Remote Control System

Item #	Part #	Description
Fig. 12		
—	1012551	12-Volt DC Marco® 125E Remote Control System – Complete
1	1012326	1/4" NPT 90° Swivel Fitting
2	1017019	1/4" X 1/4" Hex Nipple
3	10WS	Watts Strainer
4	1012051	1/4" NPT Brass Elbow <i>(Two Required)</i>
5	1012000	Abrasive Trap – Complete <i>(see Figure 19)</i>
6	1012050	1" Outlet Valve – Complete <i>(see Figure 18)</i>
7	1011501	1-1/2" NPT (M) x 1-1/4" NPT (F) Bushing
8	10TL040	Coupled Pneumatic Twinline Hose – 40 Inches
9	1012200	1-1/2" Inlet Valve – Complete <i>(see Figure 17)</i>
10	10CL18	Coupled Pneumatic Control Line – 18 inches
11	1015542	50 Feet of Electric Control Line with Male and Female Twist-Lock Plugs <i>(Includes Item #'s: 12, 13, and 14 (Quantity of 50 Feet))</i>
12	1015551	2-prong Twist-Lock Plug – Male
13	1015552	2-prong Twist-Lock Plug – Female
14	1015540	16/2 Power Cord – per foot
15	1015600	Marco® 156E Remote Control Switch – Complete
16	1030718	Battery Clamps (pair)
17	1015541	Battery Clamp Kit <i>(Includes Item #'s: 13, 14 (Quantity of Two Feet), and 16)</i>
18	1015543	25 Feet of Electric Control Line with Male and Female Twist-Lock Plugs <i>(Includes Item #'s: 12, 13, and 14 (Quantity of 25 Feet))</i>
19	1019001	12-Volt DC 190 Electric Control Assembly <i>(See Figure 11)</i>

PART NUMBERS AND SCHEMATICS

Figure 12: 12-Volt DC Marco® 125E Remote Control System

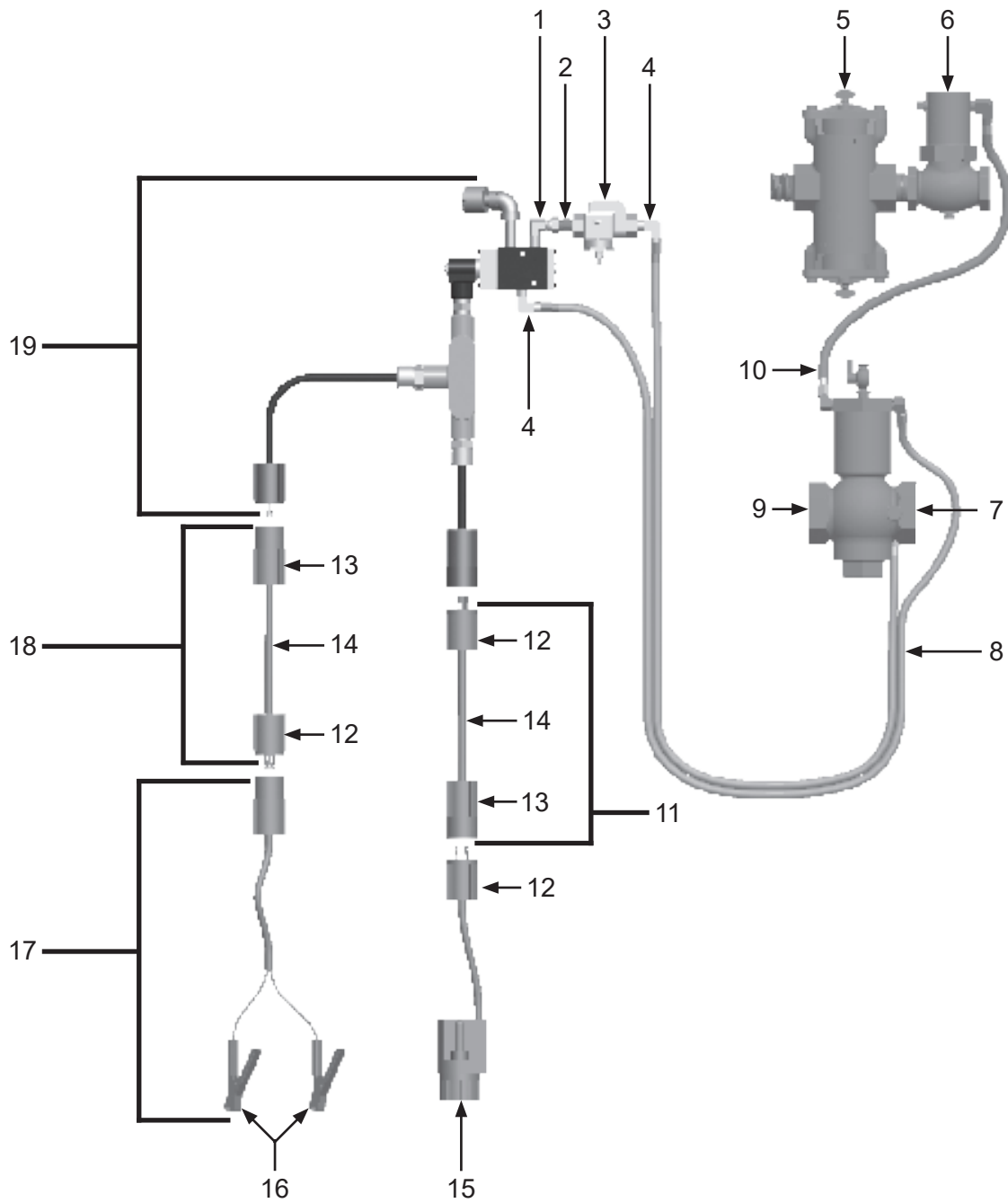

PART NUMBERS AND SCHEMATICS

Figure 13: 12-Volt DC 190 Electric Control Assembly

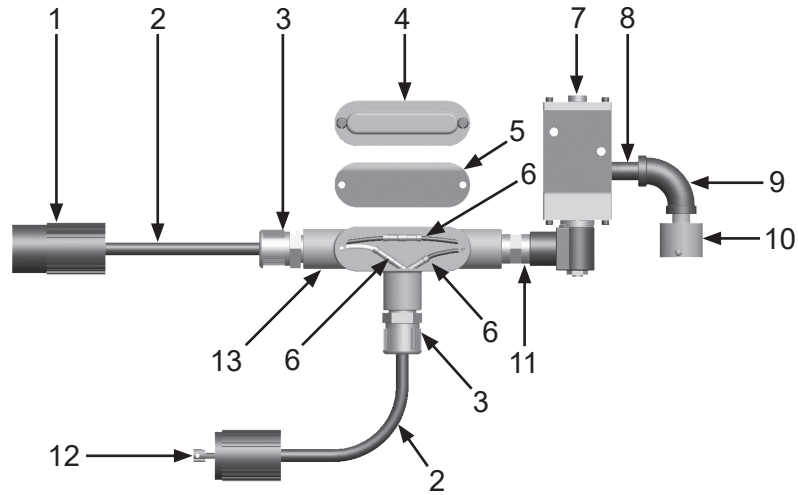

Item #	Part #	Description
Fig. 13		
—	1019001	12-Volt DC 190 Electric Control Assembly – Complete
1	1015552	2-prong Twist-Lock Plug – Female
2	1015540	16/2 Electric Cord – per foot
3	1019021	Cord Grip (<i>Two Required</i>)
4	1019022	Conduit Box Cover
5	1019023	Conduit Box Cover Gasket
6	1030028	Butt Splicer
7	1019010	12-Volt DC Electric Solenoid – Complete (<i>see Figure 12</i>)
8	1011217	1/4" x 2" Pipe Nipple
9	1011832	1/4" NPT 90° Pipe Nipple
10	10DE025	Dust Eliminator
11	20100677	1/2" x 1/2" NPT Hex Nipple
12	1015551	2-prong Twist-Lock Plug – Male
13	1090020	1/2" Tee Conduit Box

PART NUMBERS AND SCHEMATICS

Figure 14: 12-Volt DC 190 Electric Solenoid

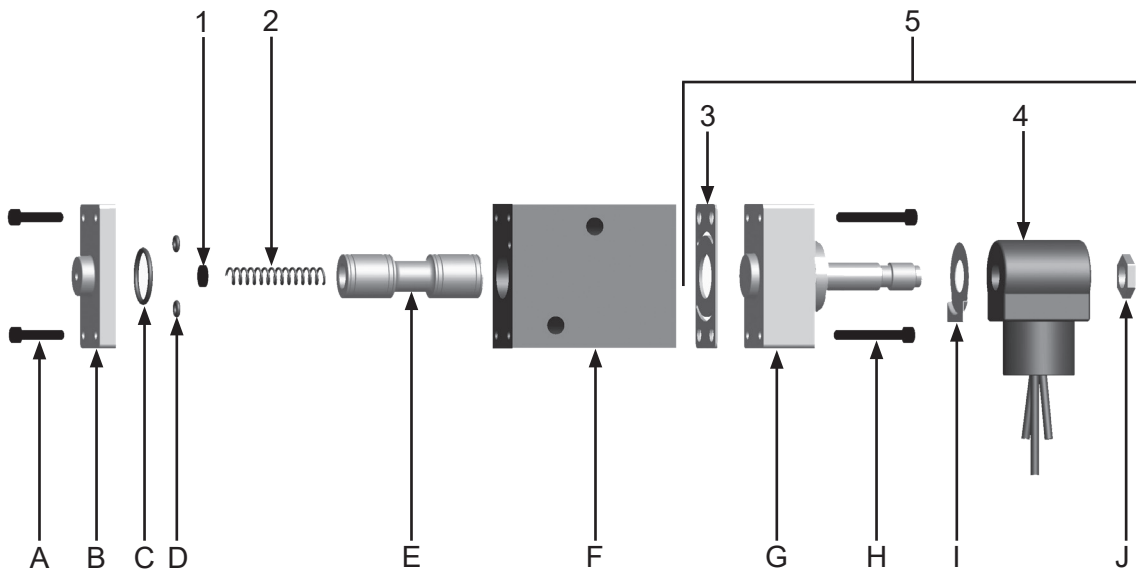

Item #	Part #	Description
--------	--------	-------------

Fig. 14

—	1019010	12-Volt DC 190 Electric Solenoid – Complete
---	----------------	--

1	1019029	Felt Filter
---	---------	-------------

2	1019032	Spring
---	---------	--------

3	1019033	Gasket
---	---------	--------

4	1019039	12-Volt DC Coil
---	---------	-----------------

5	1019034	12-Volt DC Operator Assembly (Includes Items: #3, #4, G, H, I, and J)
---	---------	--

—	1019030	Electric Solenoid Repair Kit (Includes Items: #1, #2, #3, C, D, and E)
---	---------	---

* Items A–J are not available individually

PART NUMBERS AND SCHEMATICS

120-Volt AC Marco® 125E Remote Control System

Item #	Part #	Description
Fig. 15		
—	1012552	120-Volt AC Marco® 125E Remote Control System – Complete
1	1012326	1/4" NPT 90° Swivel Fitting
2	1017019	1/4" X 1/4" Hex Nipple
3	10WS	Watts Strainer
4	1012051	1/4" NPT Brass Elbow <i>(Two Required)</i>
5	1012000	Abrasive Trap – Complete <i>(see Figure 19)</i>
6	1012050	1" Outlet Valve – Complete <i>(see Figure 18)</i>
7	1011501	1-1/2" NPT (M) x 1-1/4" NPT (F) Bushing
8	10TL040	Coupled Pneumatic Control Line – 40 Inches
9	1012200	1-1/2" Inlet Valve – Complete <i>(see Figure 17)</i>
10	10CL18	Coupled Pneumatic Control Line – 18 inches
11	1015542	50 Feet of Electric Control Line with Male and Female Twist-Lock Plugs <i>(Includes Item #'s: 12, 13, and 14 (Quantity of 50 Feet))</i>
12	1015551	2-prong Twist-Lock Plug – Male
13	1015552	2-prong Twist-Lock Plug – Female
14	1015540	16/2 Power Cord – per foot
15	1015600	Marco® 156E Remote Control Switch – Complete
16	1030020	Marco 120-Volt AC to 12-Volt AC Power Converter <i>(see Figure 16)</i>
17	1019002	12-Volt AC 190 Electric Control Assembly <i>(see Figure 14)</i>

PART NUMBERS AND SCHEMATICS

Figure 15: 120-Volt AC Marco® 125E Remote Control System

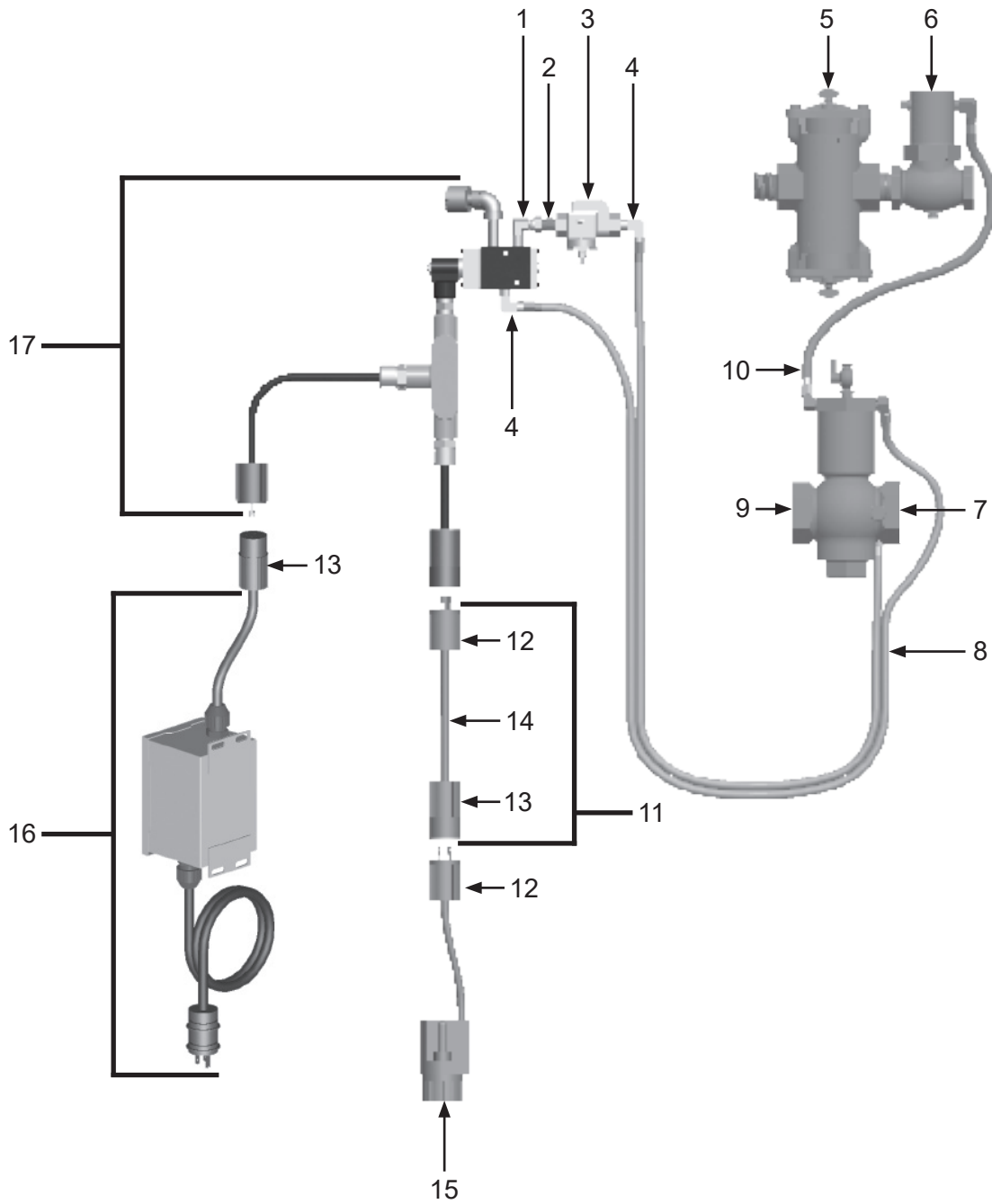

PART NUMBERS AND SCHEMATICS

Figure 16: 12-Volt AC 190 Electric Control Assembly

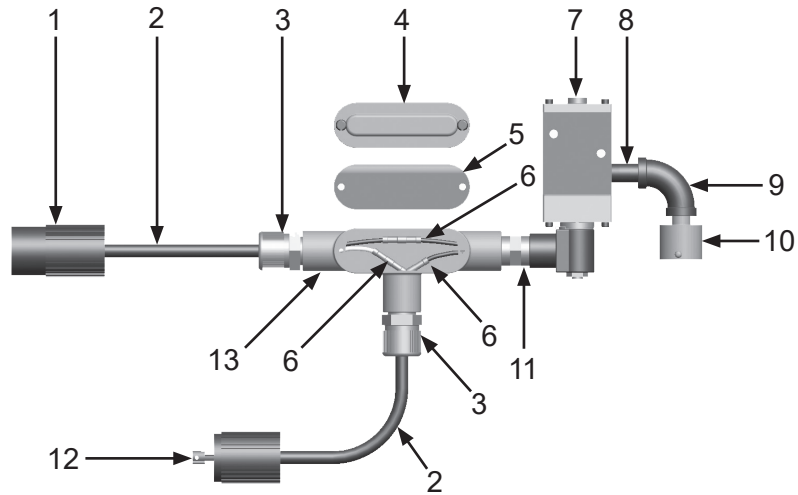

Item #	Part #	Description
Fig. 16		
—	1019002	12-Volt AC 190 Electric Control Assembly – Complete
1	1015552	2-prong Twist-Lock Plug – Female
2	1015540	16/2 Power Cord – per foot
3	1019021	Cord Grip (<i>Two Required</i>)
4	1019022	Conduit Box Cover
5	1019023	Conduit Box Cover Gasket
6	1030028	Butt Splicer
7	1019011	12-Volt AC Electric Solenoid – Complete (<i>see Figure 15</i>)
8	1011217	1/4" x 2" Pipe Nipple
9	1011832	1/4" NPT 90° Pipe Nipple
10	10DE025	Dust Eliminator
11	20100677	1/2" x 1/2" NPT Hex Nipple
12	1015551	2-prong Twist-Lock Plug – Male
13	1090020	1/2" Tee Conduit Box

PART NUMBERS AND SCHEMATICS

Figure 17: 12-Volt AC 190 Electric Solenoid

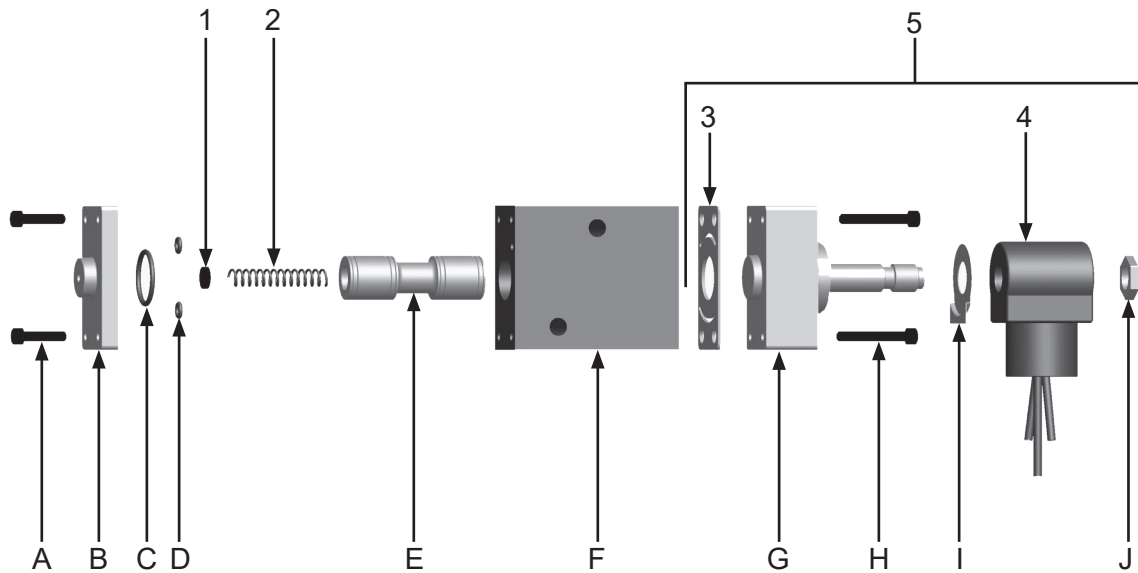

Item #	Part #	Description
Fig. 17		
—	1019011	12-Volt AC 190 Electric Solenoid – Complete
1	1019029	Felt Filter
2	1019032	Spring
3	1019033	Gasket
4	1019040	12-Volt AC Coil
5	1019035	12-Volt AC Electric Operator Assembly (Includes Items: #3, #4, G, H, I, and J)
—	1019030	12-Volt AC Electric Solenoid Repair Kit (Includes Items: #1, #2, #3, C, D, and E)
* Items A–J are not available individually		

PART NUMBERS AND SCHEMATICS

Marco® Regulator Abrasive Metering Valve

Item # Part #

Fig. 18

—	1014000	Marco® Regulator Abrasive Metering Valve – Complete
1	1014022	1/2" Hex Nut (<i>Eight Required</i>)
2	1014001	Upper Body
3	1014004	Body Gasket (<i>Two Required</i>)
4	1014003	Valve Core
5	1014005	Stainless Disc
6	1014012	Shaft Gasket
7	1014002	Lower Body
8	1014021	1/2" x 1-3/4" Hex Bolt (<i>Four Required</i>)
9	1014023	Packing Rope
10	1014011	Packing Gland
11	1012105	Spring (1-11/16" Long)
12	1014006	Heavy-Duty Handle
13	1014026	Pin
14	1014025	Pin Clip
15	1014024	1-1/4" "Y" Fitting
16	1011207	1-1/4" x 4" Nipple
17	1014010	Stud (<i>Two Required</i>)
18	1014016	1/4" Wing Nut
19	1014017	1/4" Flat Washer
20	1014008	Spacer
21	1012154	1/4" x 1" Hex Bolt
22	1014018	1/4" x 1/2" Set Screw (<i>Two Required</i>)
23	1014007	Gauge
24	1012112	2" O.D. x 1/8" O-ring
25	1014013	Inspection Plate
26	1014020	5/16" Wing Nut (<i>Two Required</i>)
27	1014019	5/16" x 1-1/4" Bolt (<i>Two Required</i>)
28	1014015	1-1/2" NPT Close Nipple
—	1091045	Hazard Identification Tag

PART NUMBERS AND SCHEMATICS

Figure 18: Marco® Regulator Abrasive Metering Valve

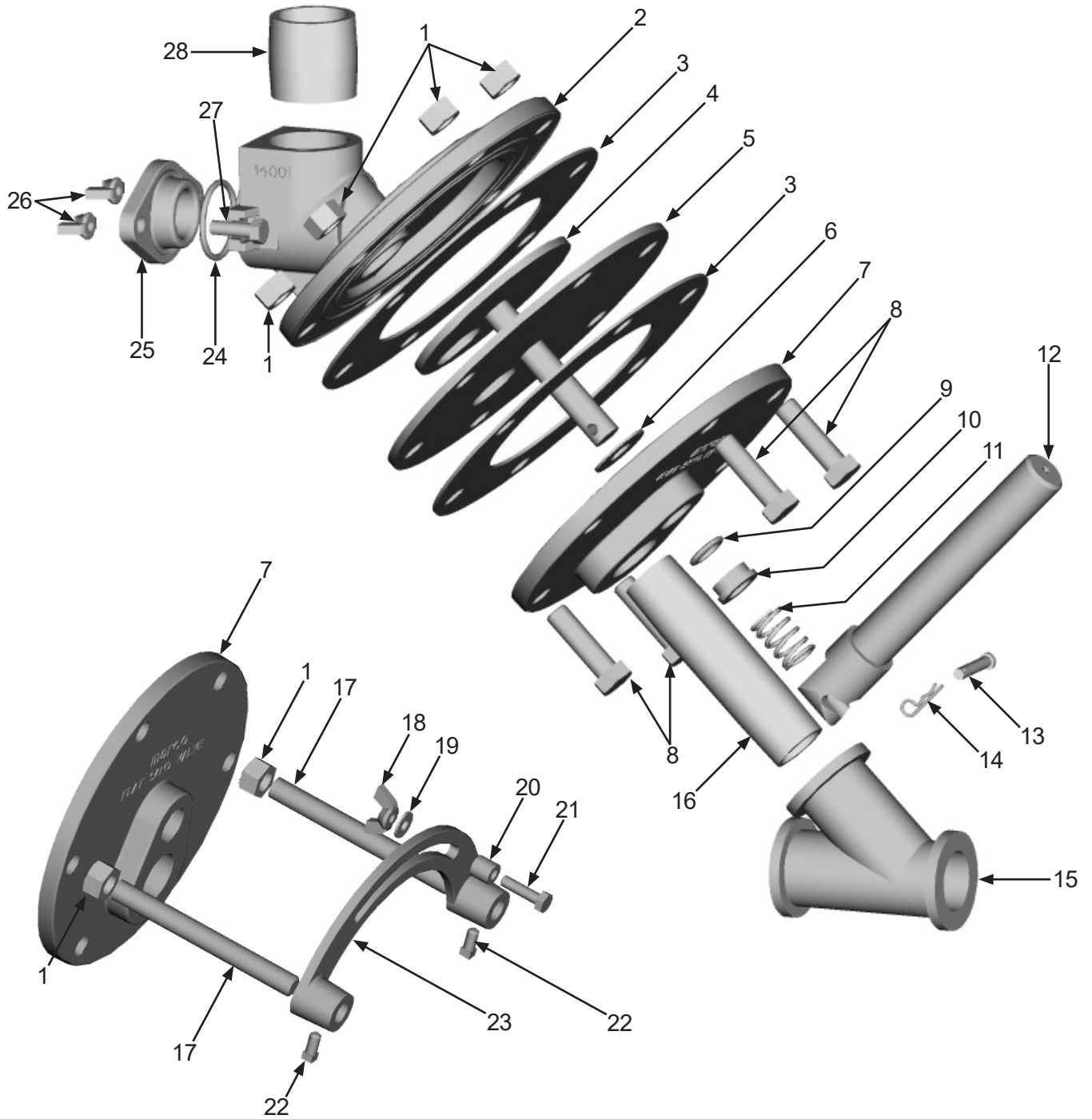

OPTIONAL ACCESSORIES

Figure 19: 1-1/4" Junior Extractor Abrasive Blasting Pot Moisture Separator

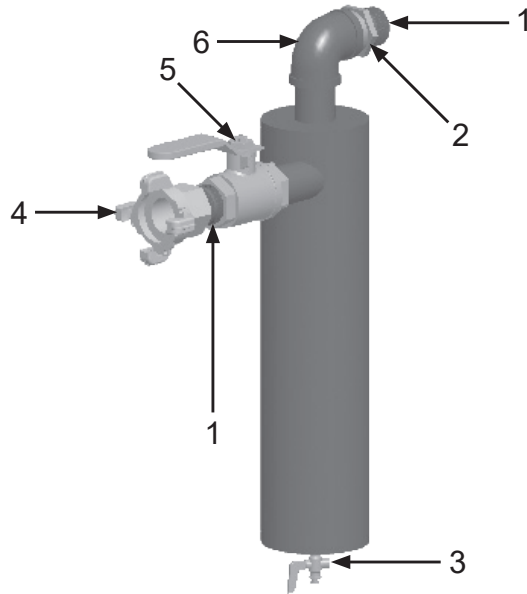

Item #	Part #	Description
Fig. 19		
—	10101314	1-1/4" Junior Extractor Abrasive Blasting Pot Moisture Separator
1	1011201	1-1/4" NPT Close Nipple (<i>Two Required</i>)
2	1011501	1-1/2" x 1-1/4" Bushing
3	1012101	1/4" NPT Brass Petcock
4	10ME3	4-Lug Air Hose End – 1-1/4" NPT (F)
5	1011602	1-1/4" NPT Full Port Ball Valve
6	1006204	1-1/4" NPT 90° Elbow
—	105M039	Features and Specifications Guide – Abrasive Blasting Pot Moisture Separators
—	106M039	Part Numbers and Schematics Guide – Abrasive Blasting Pot Moisture Separators

OPTIONAL ACCESSORIES

Figure 20: Lid and Screen

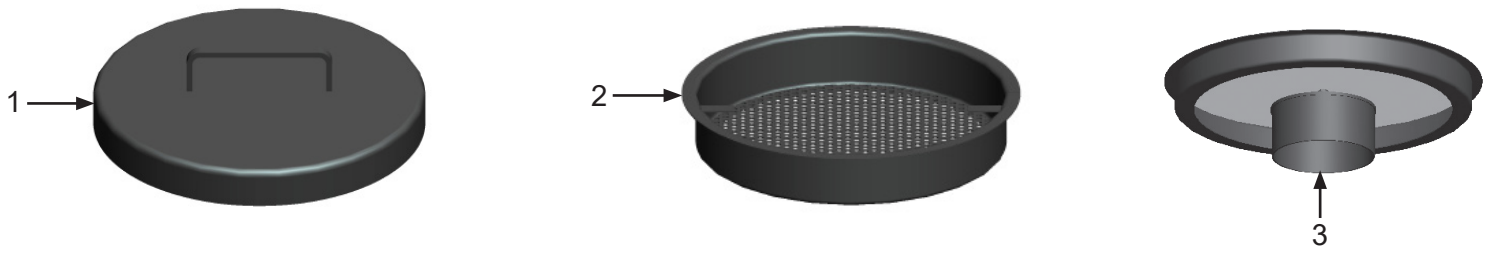

Item #	Part #	Description
1	1003101	16" Lid
2	1003102	16" Screen
3	10100732	Abrasive Umbrella (Screen Not Included)

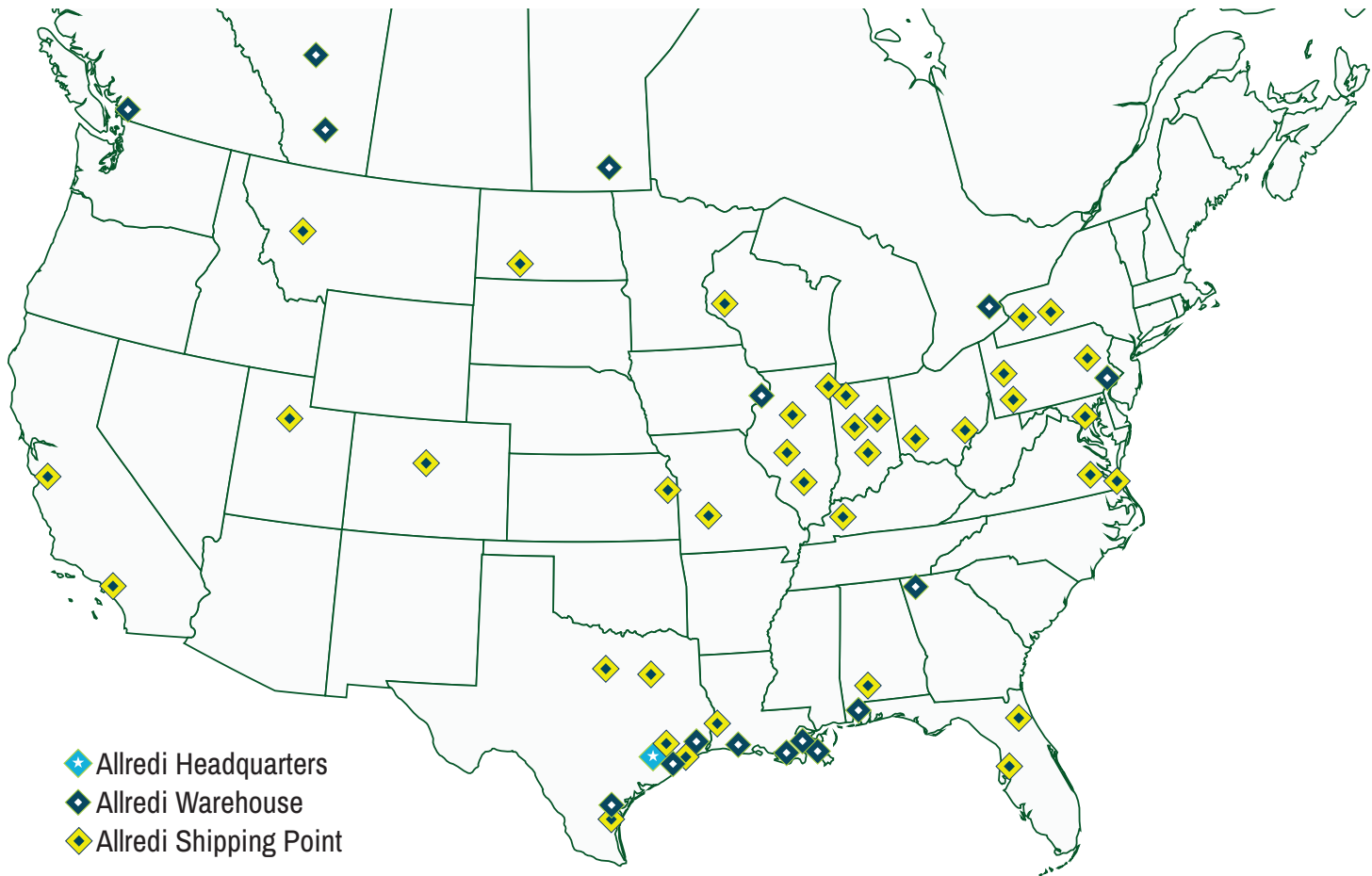

ALLREDI THERE

Serving these industries: Bridge, Pipeline, Tank & Tower, Concrete Services, Rail, Shipyard & Marine, Pools & Fountains, and Foundry

UNITED STATES

Pasadena, TX (*Headquarters*)
844.361.7038

Beaumont, TX
409.722.1284

Bristol, PA
215.826.8080

Corpus Christi, TX
361.887.2038

Davenport, IA
563.324.2519

Deer Park, TX
(*Service & Rental Location*)
281.930.0905

Duluth, GA
800.535.4564

Gonzales, LA
225.647.7575

Harvey, LA
504.367.8090

Houma, LA
985.580.4273

Lafayette, LA
337.267.1440

Theodore, AL
251.338.7525

CANADA

Calgary, Alberta
403.279.1924

Coquitlam, BC
604.464.6979

Edmonton, Alberta
780.468.2588 (Manus)
780.425.5510 (Mod-U-Blast)

Hamilton, Ontario
905.527.6000 / 888.794.5665

Mississauga, Ontario
905.890.5837

Winnipeg, Manitoba
204.256.3324

WWW.ALLREDI-US.COM / 800.252.7848

WWW.ALLREDI-CA.COM / 800.661.3842

Allredi™ and Marco® are registered trademarks of Allredi, LLC.
Mod-U-Blast® is a registered trademark of Allredi Blast & Abrasives Canada, Inc.
All other brand names or marks are used for identification purposes and are trademarks of their respective owners.

ALLREDI™

Literature #106M071_5/13/2024