



MARCO® 1600 CFM AIR DRYERS



Powered by **ALLREDI**.

PART NUMBERS AND SCHEMATICS GUIDE

Company Profile

Allredi was formed in the early 2020, when two of the largest distributors in the blasting, coating, safety, and environmental industry, APE Companies and Marco Group International, joined forces. While the qualities both companies are known for have not changed, a lot about our business is new. New abilities. New agilities. New ways to help you win. This calls for a new name, Allredi.

This name exemplifies what we have become. It is completely oriented to the needs of our customers. To your needs. It says that when you call us for anything – products, service, expert advice, anything – you can consider it done. Or even better, Allredi done.

We are your right-now supplier. From skills to SKUs, we deliver the goods fast. So you can be more agile every minute, every day. This is who we are. This is what our new name means. Go ahead and expect excellence, because we're bringing it.

Our Mission and Vision

To be the industry's preferred partner in surface preparation solutions through unrivaled technical expertise, customer experience, product availability, and tailored service offerings.

The Allredi Difference

- **Industry Experience** – With Allredi on your team, you have access to expertise which can only come from decades of industry leadership. We have organized our engineering department, production specialists, customer operations, and safety support into a “Center of Competence.” As an Allredi customer, you have access to hundreds of years of cumulative experience related to your operations.
- **Manufacturing Excellence** – Allredi is a U.S. based manufacturer of equipment for the Surface Preparation and Protective Coatings industries. Allredi's engineers benchmark the industry to ensure that we design and manufacture superior products that set the “Gold Standard” for performance, safety, and quality.
- **Legendary Customer Service** – Allredi's legendary customer service team is staffed by friendly, highly-trained individuals who are focused on providing the highest level of product support, order accuracy, and customer satisfaction.
- **Product Availability** – We stock over 10,000 SKU's and have over 45 shipping locations to serve North American and International markets for all major brands of blasting, coating, environmental, and safety equipment. Allredi is your right-now supplier, so you can keep your projects moving. From our foundation of strong relationships, we have built a nationwide network that puts vast inventory and ready service close to our customers. We provide advanced expertise, and we deliver the goods fast – so you can easily access the products and services you need to me more agile every minute, every day.
- **Technology Leadership** – Our website provides: Operator's Manuals, Part Numbers and Schematics Guides, SDS information, and key product features and specifications, providing access to information 24/7.

TABLE OF CONTENTS

Company Profile	2
Table of Contents	3
Part Numbers	4
Specifications	5
Part Numbers & Schematics	6-17
Marco® 1600 CFM Air Dryer—Pneumatic.....	6-7
Marco® 1600 CFM Air Dryer—Electric	8-9
Aftercooler Assembly—Pneumatic.....	10
Aftercooler Assembly—Electric	11
Transfer Hose Assembly.....	12
Inlet Filter Assembly	13
Air Regulator/Lubricator	14
Inspection Door Assembly	15
Outlet Filter.....	16
Desiccant Tablets and Spherical Tower Packing ...	17
Optional Accessories	17-19
Desiccant Tablets	17
Spherical Tower Packing	17
Airflow Shutoff Kits – Lug Fittings.....	18
Airflow Shutoff Kits – Hammerlock Fittings.....	18
Inlet/Outlet Bushing	19
Pipe Plugs	19
Lubrication	19

PART NUMBERS

MARCO® 1600 CFM AIR DRYER									
Part Numbers	Inlet			Outlet			Power Source	Filter, Regulator, and Lubricator	Electric Starter Box
	Inlet Quantity	Inlet Size	Fittings	Outlet Quantity	Outlet Size	Fittings			
10101670	1	3"	Not Included	5	(2) 3", (1) 1-1/4", (2) 1"	Not Included	Pneumatic	Included	Not Included
10101671	1	3"	Not Included	5	(2) 3", (1) 1-1/4", (2) 1"	Not Included	230-Volt AC	Not Included	Included

Dessicant tablets not included with Marco® 1600 CFM Air Dryers

SPECIFICATIONS

Lubrication: SAE 10 oil or Air Tool Anti-freeze Lubricant

Empty Weight: 1390 Pounds

Overall Dimensions: A: 91"
B: 35"
C: 72"

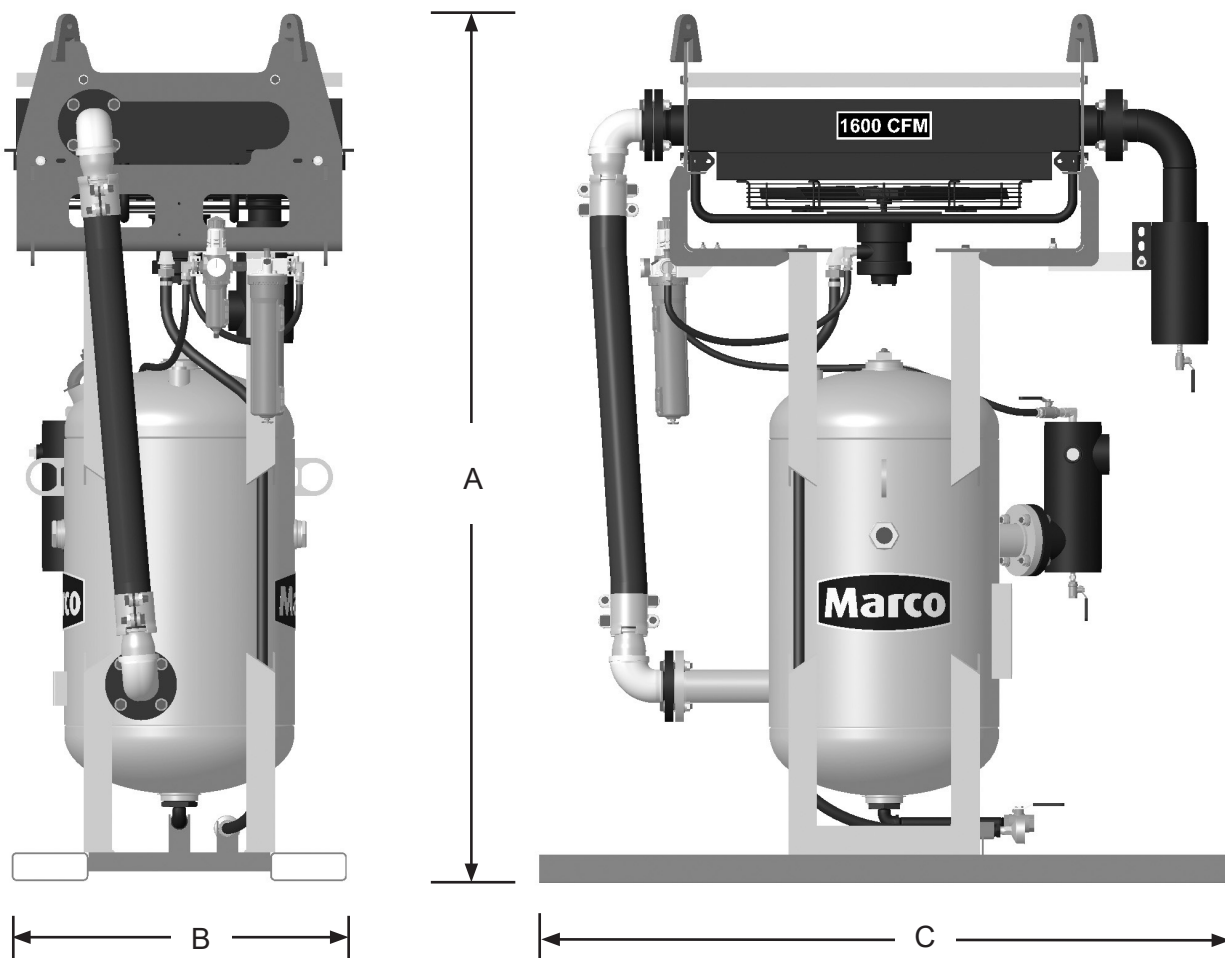

Pneumatic model shown. Electric model has same dimensions.

PART NUMBERS & SCHEMATICS

Marco® 1600 CFM Air Dryer—Pneumatic

Item #	Part #	Description	Item #	Part #	Description
Fig. 1			25	10AHCL1	Band Clamp <i>(Two Required)</i>
—	10101670	Marco® 1600 CFM Air Dryer – Pneumatic	26	—	Outlet Filter Assembly <i>(See Fig.9)</i>
1	10101033	950-1600 CFM Heat Exchanger Mounting Bracket <i>(Two Required)</i>	27	10SAP1290	1/2" 90° Swivel <i>(Four Required)</i>
2	10101943	1/2-13 x 1-1/2" Bolt Galvanized <i>(10 Required)</i>	28	20100677	1/2" x 1/2" Nipple <i>(Two Required)</i>
3	10100674	1/2" Flat Washer Galvanized <i>(16 Required)</i>	29	10AH012	1/2" I.D. Air Hose <i>(Per Foot)</i>
4	10100675	1/2" Split Lock Washer Galvanized <i>(10 Required)</i>	30	10L363	Ball Valve
5	10101941	1/2-13 Hex Nut Galvanized <i>(10 Required)</i>	31	10101034	3" NPT Galvanized Pipe Plug
6	10101166	Heat Exchanger Protective Grate	32	10105890	Filter/Regulator/Lubricator with Pressure Gauge <i>(See Fig.7)</i>
7	—	Aftercooler Core Assembly - Complete <i>(See Fig.3)</i>	33	10101170	Moisture Separator Brace
8	10101059	3/8-16 x 1-1/4" Bolt Galvanized <i>(Four Required)</i>	34	—	Inlet Filter Assembly <i>(See Fig.6)</i>
9	10101942	3/8" Flat Washer Galvanized <i>(Eight Required)</i>	35	—	Desiccant Tablets - <i>Not Included (See Fig.10)</i>
10	10L805015	3/8" Lock Washer Galvanized <i>(Four Required)</i>	36	10103922	Spherical Tower Packing <i>(See Fig.10)</i>
11	10101938	3/8-16 Hex Nut Galvanized <i>(Four Required)</i>	37	10101844	3" NPTM x 1" NPTF Bushing
12	—	Transfer Hose Assembly <i>(See Fig.5)</i>	38	10107495	1/2-13 x 1-5/8" Grade 8 Hex Bolt Zinc <i>(Four Required)</i>
13	10101002	1/2" x 1" NPT Reducing Elbow	39	10107496	1/2-13 Grade 8 Lock Nut Zinc <i>(Four Required)</i>
14	10AH100	1" I.D. Air Hose <i>(Per Foot)</i>	40	10104711	1/2" Grade 8 Flat Washer Zinc <i>(Eight Required)</i>
15	1011902	1-1/4" NPT Plug	41	10PAF050	1/2" Push-on Hose Fitting <i>(Four Required)</i>
16	—	Inspection Door Assembly <i>(See Fig.8)</i>	42	10101024	Skid Weldment
17	10101688	2" NPT Sight Glass	43	10109052	U-Bolt <i>(Two Required)</i>
18	1011801	1" NPT Street Elbow	44	10101940	1/4" Flat Washer <i>(12 Required)</i>
19	10101064	1" x 12" NPT Pipe Nipple	45	10108281	Mounting Bracket
20	1011601	1" NPT Full Port Ball Valve	46	10105903	1/4-20 x 1-1/4" Hex Bolt <i>(Four Required)</i>
21	10101800	Aftercooler Exhaust Muffler – 950 CFM–1600 CFM	47	10101939	1/4-20 Stainless Steel Lock Nut with Nylon Insert <i>(Four Required)</i>
22	1011812	1" Male x 1/2" Female Bushing	48	1094538	1600 CFM Product Sticker
23	1012151	1" Galvanized Close Nipple	—	106M117	Part Numbers and Schematics Guide – Marco® 1600 CFM Air Dryer
24	10SFE2	1" Female Swivel <i>(Two Required)</i>	—	1090117	Operator's Manual – Marco® 1600 CFM Air Dryer
			—	1094045	Hazard Identification Tag
			—	1070517	Pneumatic Tool Oil — 32 oz.

PART NUMBERS AND SCHEMATICS

Figure 1: Marco® 1600 CFM Air Dryer—Pneumatic

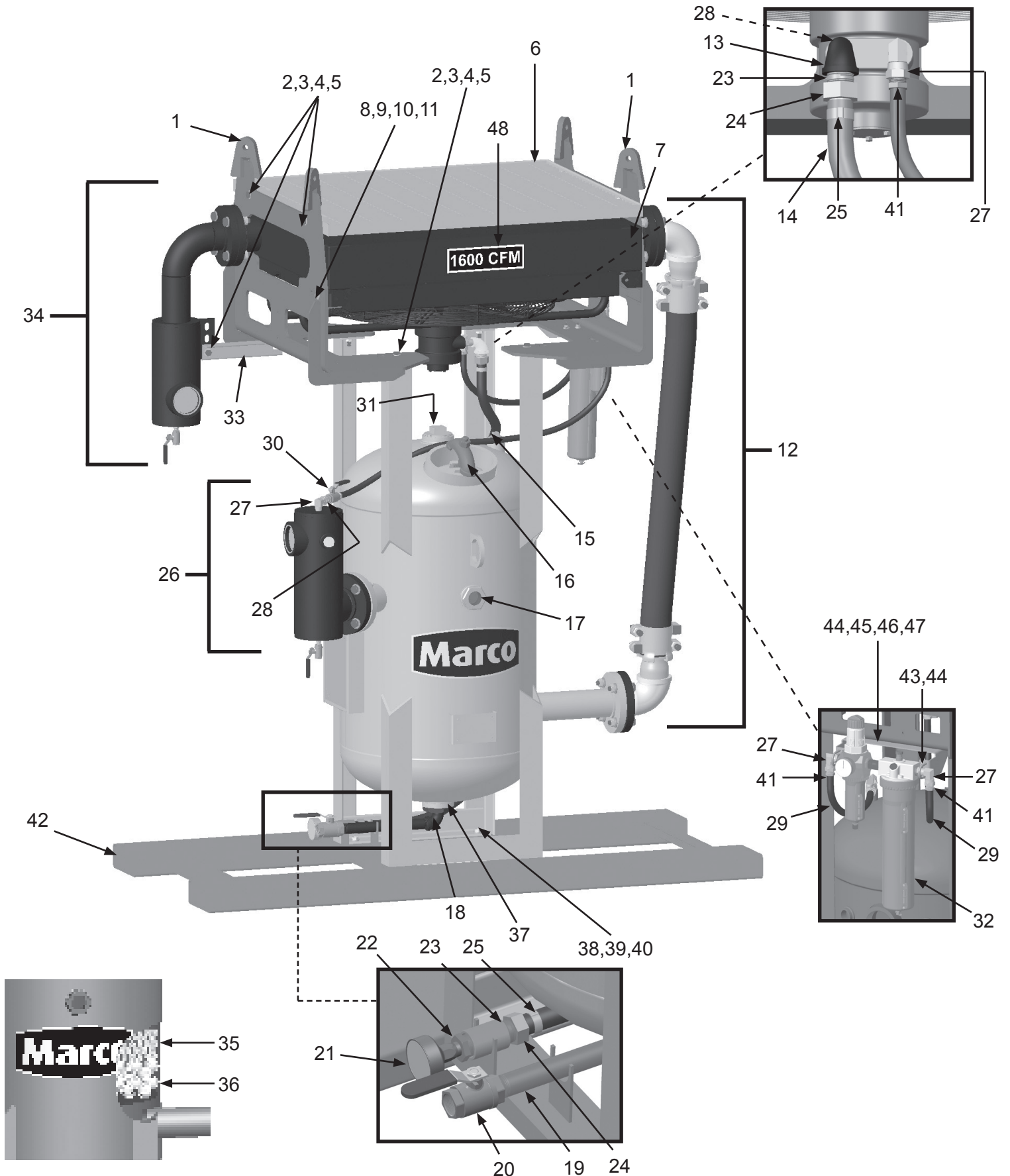

PART NUMBERS AND SCHEMATICS

Marco® 1600 CFM Air Dryer—Electric

Item #	Part #	Description	Item #	Part #	Description
Fig. 2			24	—	Inlet Filter Assembly (See Fig. 6)
—	10101671	Marco® 1600 CFM Air Dryer – Electric	25	—	Desiccant Tablets - <i>Not Included</i> (See Fig.10)
1	10101033	950-1600 CFM Heat Exchanger Mounting Bracket (<i>Two Required</i>)	26	10103922	Spherical Tower Packing (See Fig.10)
2	10101943	1/2-13 x 1-1/2" Bolt Galvanized (<i>Six Required</i>)	27	10101844	3" NPTM x 1" NPTF Bushing
3	10100674	1/2" Flat Washer Galvanized (<i>16 Required</i>)	28	10107495	1/2-13 x 1-5/8" Grade 8 Hex Bolt Zinc (<i>Four Required</i>)
4	10100675	1/2" Split Lock Washer Galvanized (<i>10 Required</i>)	29	10107496	1/2-13 Grade 8 Lock Nut Zinc (<i>Four Required</i>)
5	10101941	1/2-13 Hex Nut Galvanized (<i>Six Required</i>)	30	10104711	1/2" Grade 8 Flat Washer Zinc (<i>Eight Required</i>)
6	10101166	Heat Exchanger Protective Grate	31	20101197	3/4" NPT Cord Grip
7	—	1600 CFM Aftercooler Core Assembly - Complete (See Fig.4)	32	10103304	3/4" Flexible Conduit
8	10101059	3/8-16 x 1-1/4" Bolt Galvanized (<i>Six Required</i>)	33	10103303	3/4" Conduit Hub (<i>Two Required</i>)
9	10101942	3/8" Flat Washer Galvanized (<i>12 Required</i>)	34	1012154	1/4-20 x 1" Hex Bolt Zinc (<i>Four Required</i>)
10	10L805015	3/8" Lock Washer Galvanized (<i>Six Required</i>)	35	1014017	1/4" Flat Washer Zinc (<i>Eight Required</i>)
11	10101938	3/8-16 Hex Nut Galvanized (<i>Six Required</i>)	36	1012323	1/4"-20 Lock Nut Zinc (<i>Four Required</i>)
12	—	Transfer Hose Assembly (See Fig.5)	37	10108830	Motor Starter Bracket
13	10108792	Electric Motor Starter Box – Single Phase	38	20100160	1/2-13 x 4-1/2" Bolt Galvanized (<i>Four Required</i>)
14	1011902	1-1/4" NPT Plug	39	1094538	1600 CFM Product Sticker
15	—	Inspection Door Assembly (See Fig.8)	—	10108799	Thermal Unit - Full Load Current 23.2 - 27.1 Amps
16	10101688	2" NPT Sight Glass	—	106M117	Part Numbers and Schematics Guide – Marco® 1600 CFM Air Dryer
17	1011801	1" NPT Street Elbow	—	1090117	Operator's Manual – Marco® 1600 CFM Air Dryer
18	10101064	1" x 12" NPT Pipe Nipple	—	1091017	Hazard Identification Tag
19	1011601	1" NPT Full Port Ball Valve			
20	—	Outlet Filter Assembly (See Fig.9)			
21	20PFHA24ST08	1/2" NPT Pipe Plug			
22	10101034	3" NPT Galvanized Pipe Plug			
23	10101170	Moisture Separator Brace			

PART NUMBERS AND SCHEMATICS

Figure 2: Marco® 1600 CFM Air Dryer—Electric

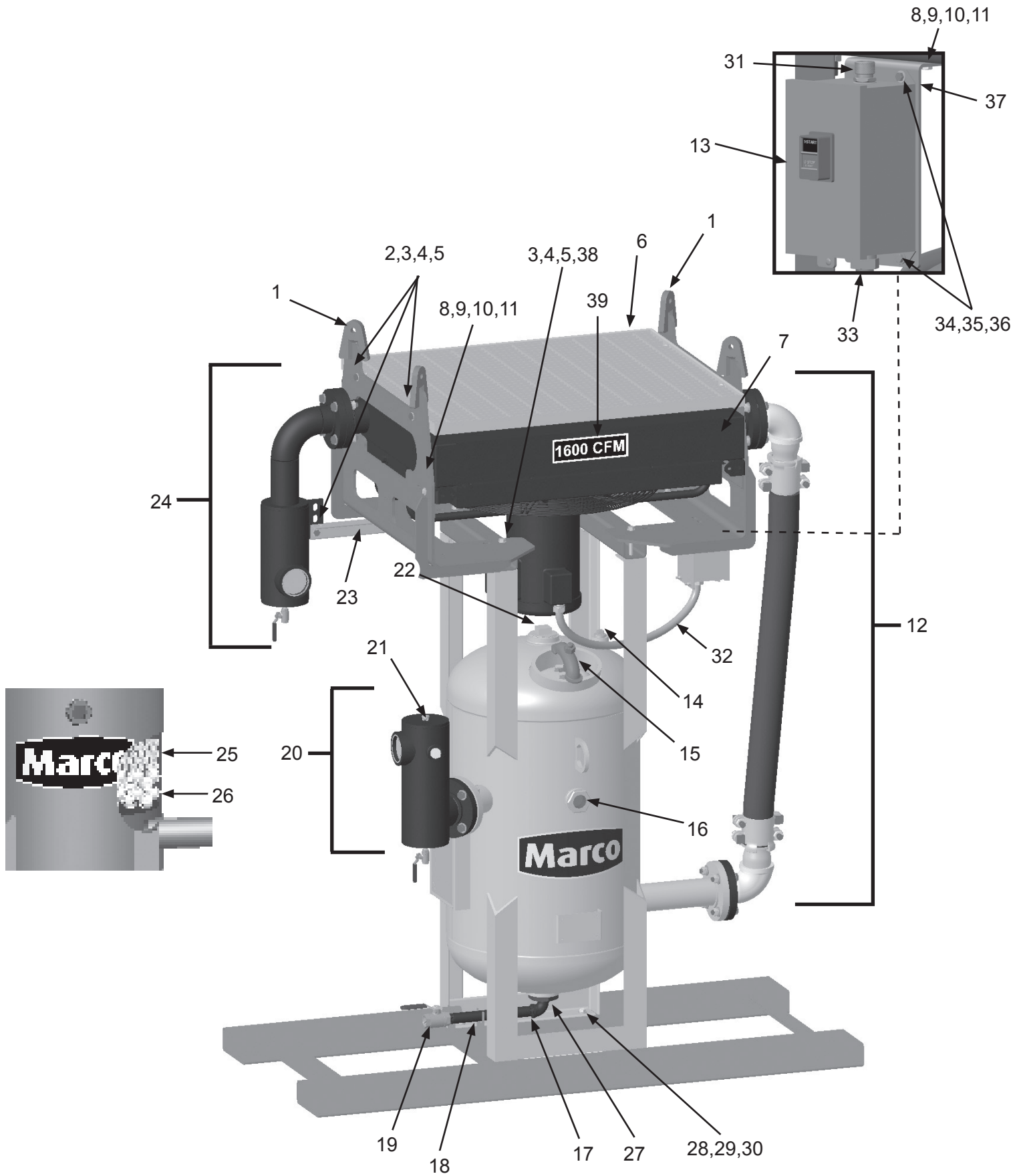

PART NUMBERS AND SCHEMATICS

Figure 3: Aftercooler Assembly—Pneumatic

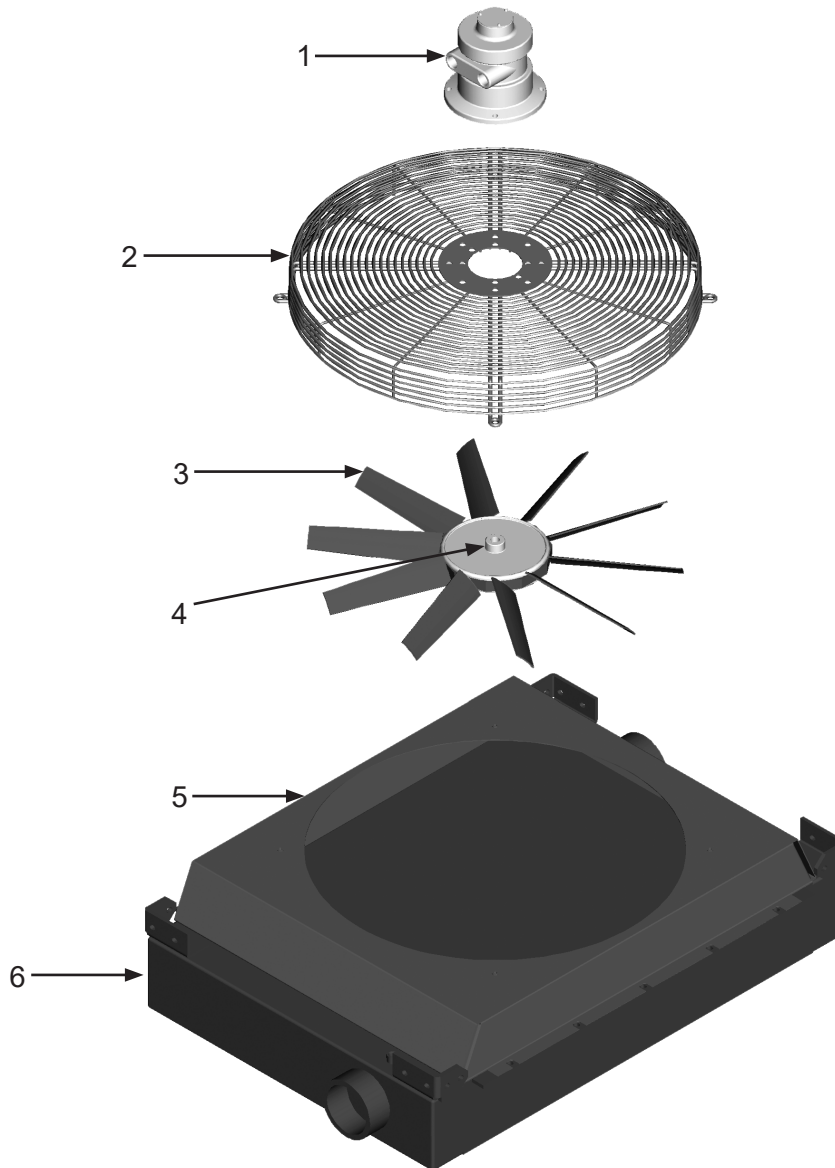

Item #	Part #	Description
--------	--------	-------------

Fig. 3

—	10TTAHP16005	1600 CFM Aftercooler Core Assembly – Complete
---	---------------------	--

1	10101804	Air Motor
---	----------	-----------

2	10101808	Fan Guard
---	----------	-----------

3	10101806	Fan Blades (Includes Blades and Hub)
---	----------	--------------------------------------

4	10101807	Fan Bushing
---	----------	-------------

5	1014172	Fan Shroud
---	---------	------------

6	10101803	Aftercooler Core
---	----------	------------------

—	1070517	Pneumatic Tool Oil - 32 oz.
---	---------	-----------------------------

—	10101805	Air Motor Service Kit (Includes: shaft seal, drive end bearing, dead end bearing, four vanes, four push pins, four vane springs, shim, end cap gasket, muffler cartridge, and muffler felt)
---	----------	--

PART NUMBERS AND SCHEMATICS

Figure 4: Aftercooler Assembly—Electric

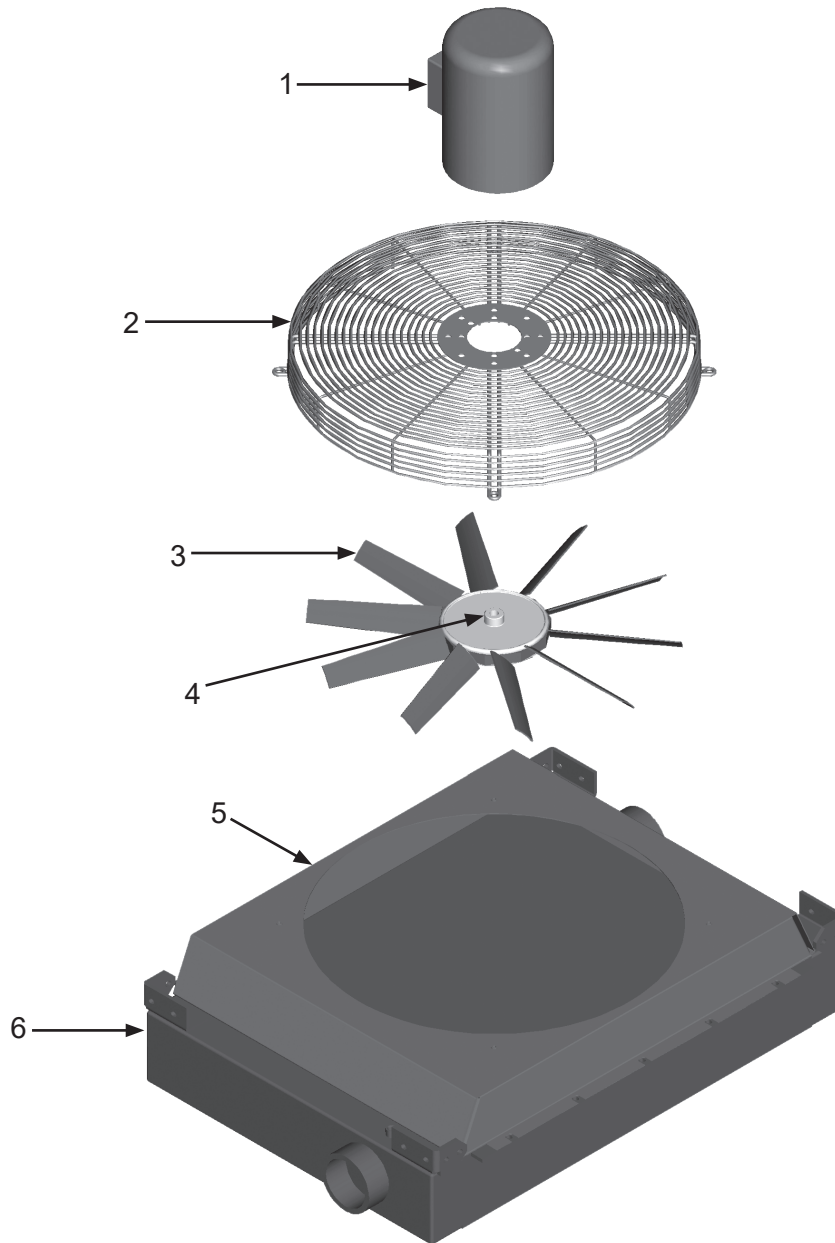

Item #	Part #	Description
--------	--------	-------------

Fig. 4

—	10TTAHP16002	1600 CFM Aftercooler Core Assembly - Complete
---	---------------------	--

1	10101809	Electric Motor – (115V/208-230V) – Single Phase
---	----------	---

2	10101808	Fan Guard
---	----------	-----------

3	10101806	Fan Blades (Includes Blades and Hub)
---	----------	--------------------------------------

4	10101807	Fan Bushing
---	----------	-------------

5	1014172	Fan Shroud
---	---------	------------

6	10101803	Aftercooler Core
---	----------	------------------

—	1070517	Pneumatic Tool Oil - 32 oz.
---	---------	-----------------------------

PART NUMBERS AND SCHEMATICS

Figure 5: Transfer Hose Assembly

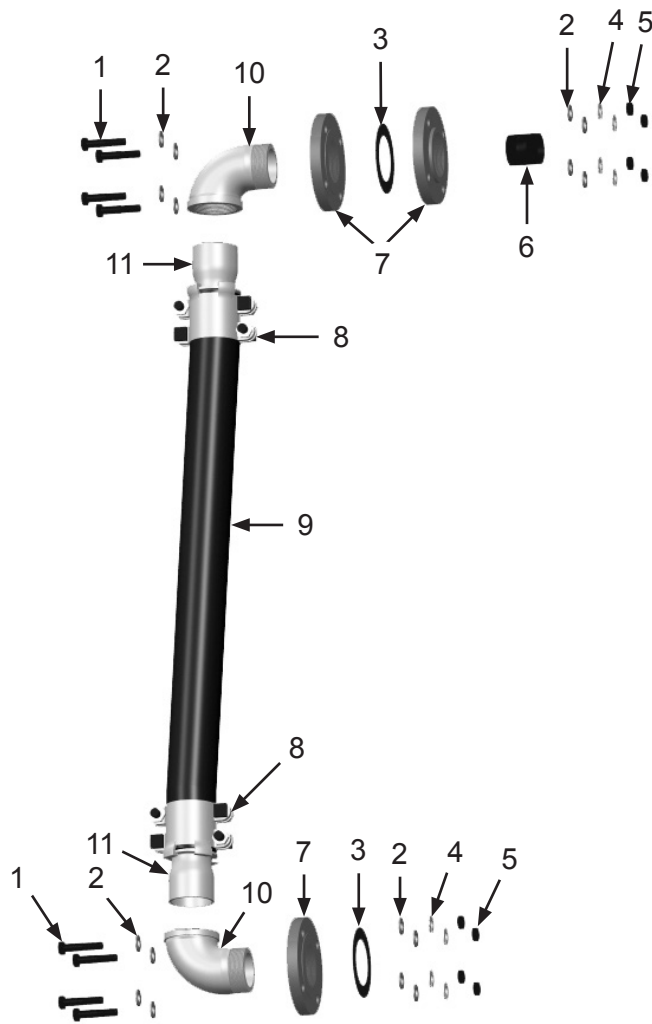

Item #	Part #	Description
Fig. 5		
1	10101058	5/8-11 x 3" Grade 8 Bolt (Eight Required)
2	10101060	5/8" Flat Washer (16 Required)
3	10101047	Flange Gasket (Two Required)
4	10103399	5/8" Grade 8 Split Lock Washer (Eight Required)
5	10103393	5/8-11 Grade 8 Hex Nut (Eight Required)
6	10101040	3" NPT Close Nipple
7	10101041	3" NPT Threaded Flange (Three Required)
8	10BU35	3" Boss Clamp (Two Required)
9	10101045	3" x 2-1/2' Steel Reinforced Air Hose (Per Foot)
10	10101148	3" NPT Street Elbow (Two Required)
11	10101754	3" NPT Hose Stem (Two Required)

PART NUMBERS AND SCHEMATICS

Figure 6: Inlet Filter Assembly

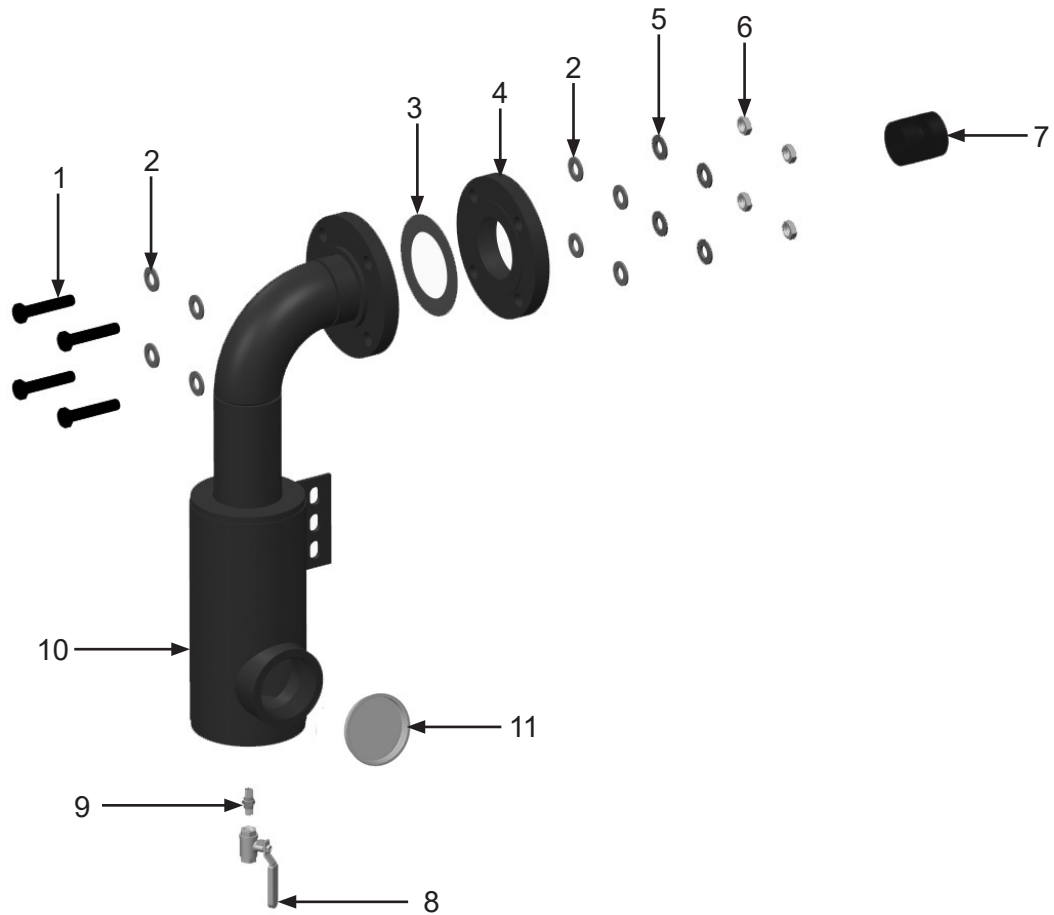

Item #	Part #	Description
--------	--------	-------------

Fig. 6

1	10101058	5/8-11 x 3" Grade 8 Bolt (<i>Four Required</i>)
2	10101060	5/8" Flat Washer (<i>Eight Required</i>)
3	10101047	Flange Gasket
4	10101041	3" NPT Threaded Flange
5	10103399	5/8" Grade 8 Split Lock Washer (<i>Four Required</i>)
6	10103393	5/8-11 Grade 8 Hex Nut (<i>Four Required</i>)
7	10101040	3" NPT Close Nipple
8	1080050	1/4" NPT Full Port Ball Valve
9	1017019	1/4" NPT Hex Nipple
10	10101049	Inlet Moisture Separator
11	10101238	3" NPT Transport Plug

PART NUMBERS AND SCHEMATICS

Figure 7: Air Filter/Regulator/Lubricator

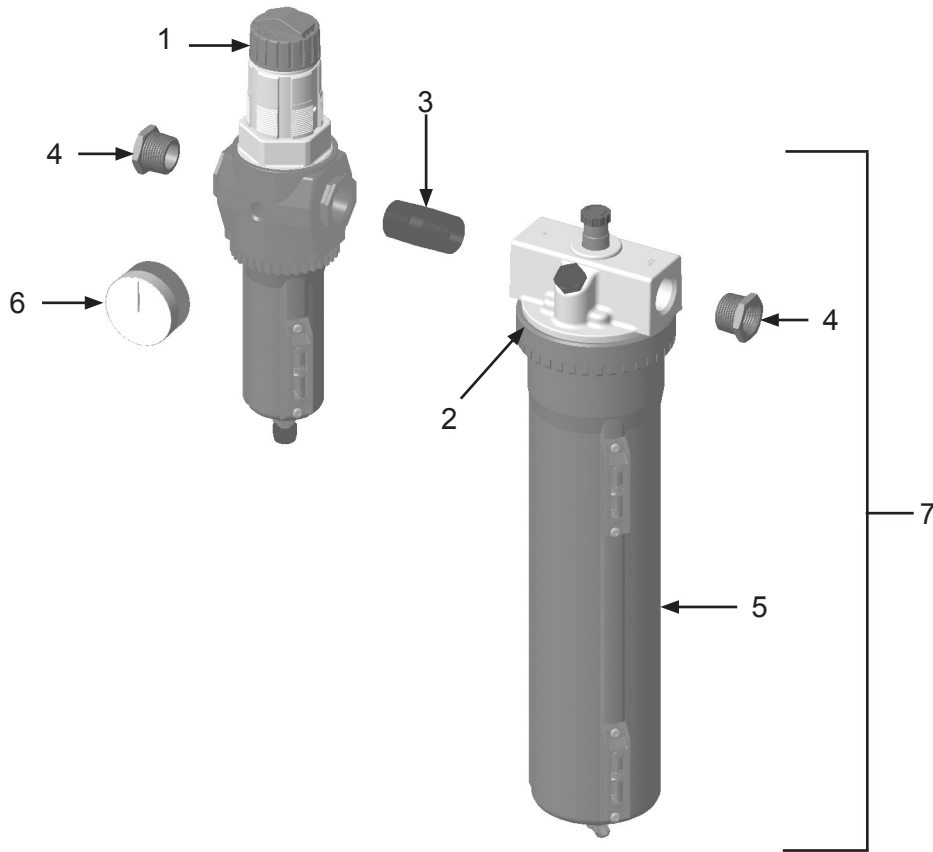

Item #	Part #	Description
Fig. 7		
	10105890	Air Filter/Regulator/Lubricator with Pressure Gauge—Pneumatic—Complete
1	10105891	Filter/Regulator
2	10106432	Large O-ring - Lubricator
3	10105894	3/4" x 2" Pipe Nipple
4	10105895	Coupler with 3/4" x 1/2" Reducing Bushing <i>(Two Required)</i>
5	10106507	Lubricator Bowl
6	1028606	Pressure Gauge – 0-160 PSI 1/4" – Back Mount
7	10110133	Lubricator <i>Includes #s: 2 and 5</i>
—	1070517	Pneumatic Tool Oil - 32 oz.
—	10106504	Diaphragm Kit for Filter/Regulator
—	10106505	Bowl, O-Ring and Site Gauge Kit for Filter/Regulator
—	10106506	Cartridge Kit for Lubricator

PART NUMBERS AND SCHEMATICS

Figure 8: Inspection Door Assembly

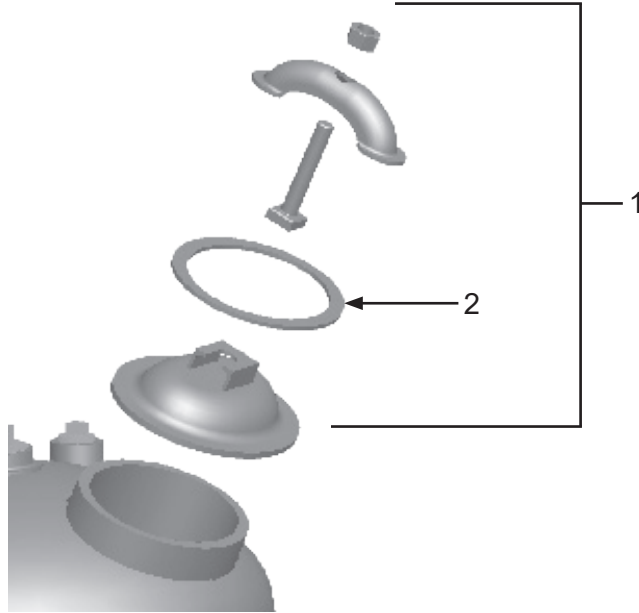

Item #	Part #	Description
Fig. 8		
1	10106105	Air Dryer Inspection Door Assembly – Complete <i>Includes Item #2</i>
2	1006201	Inspection Door Gasket

PART NUMBERS AND SCHEMATICS

Figure 9: Outlet Filter

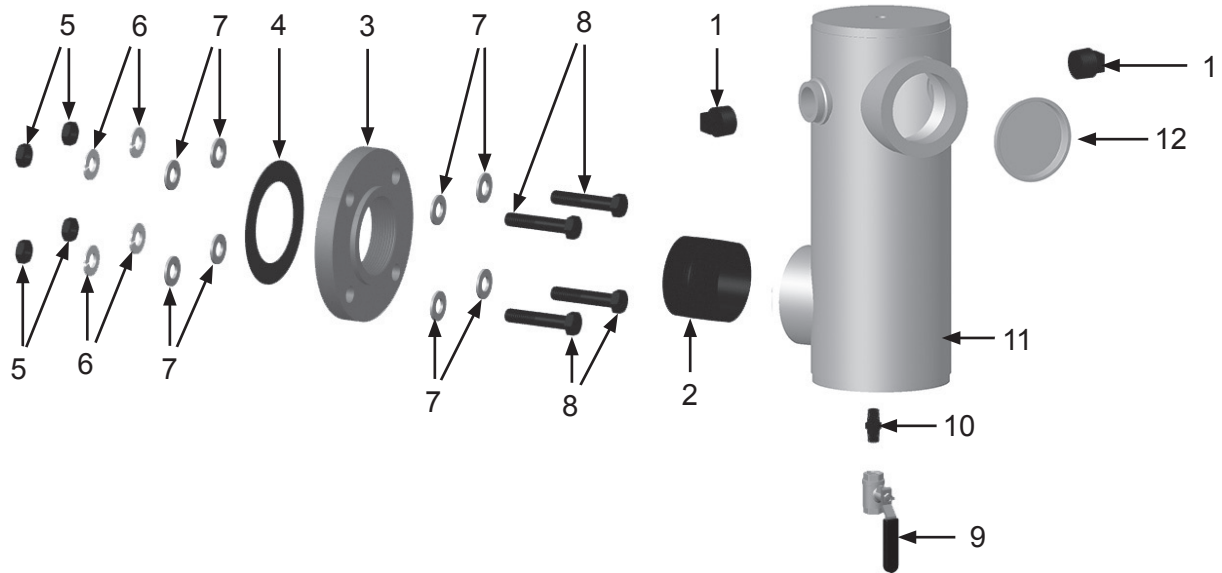

Item #	Part #	Description
--------	--------	-------------

Fig. 9

1	1011901	1" NPT Galvanized Square Head Pipe Plug <i>(Two Required)</i>
2	10101040	3" NPT Galvanized Close Nipple
3	10101041	3" NPT Threaded Flange
4	10101047	Flange Gasket
5	10103393	5/8-11 Grade 8 Hex Nut <i>(Four Required)</i>
6	10103399	5/8" Lock Washer <i>(Four Required)</i>
7	10101060	5/8" Flat Washer <i>(Eight Required)</i>
8	10101058	5/8-11 x 3" Grade 8 Hex Bolt <i>(Four Required)</i>
9	1080050	1/4" Ball Valve
10	1017019	1/4" Hex Nipple
11	10101686	Outlet Filter Body
12	10101238	3" NPT Transport Plug

OPTIONAL ACCESSORIES

Figure 10: Desiccant Tablets and Spherical Tower Packing

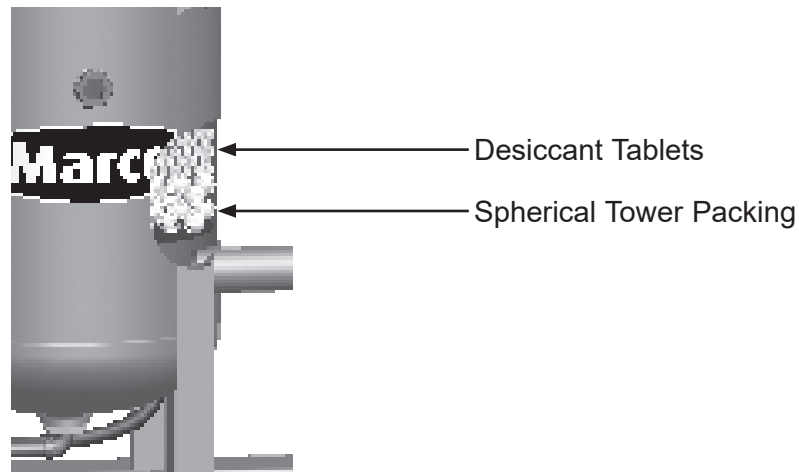









Part Numbers	DESICCANT TABLETS	
	Package Weight	Packaging
10V330311	50 pounds	Bag
15V330313	50 pounds	Pail
15V330203	506 pounds	Steel Drum
15V330284	2000 pounds	Bulk Bag

Van Air Systems Dry-O-Lite® – SDS – 108V116

Part Numbers	SPHERICAL TOWER PACKING	
	Unit of Measure	
10103922	1 Cubic Foot	





OPTIONAL ACCESSORIES

AIRFLOW SHUTOFF KITS – LUG FITTINGS					
	Part Numbers	Pipe String I.D.	Close Nipple	Full Port Ball Valve	Coupling
	10103731	1"	1012151	1011601	10ME2
	10103732	1-1/4"	1011201 <i>(Quantity of Two)</i>	1011602	10ME3
	10103733	1-1/2"	1014015 <i>(Quantity of Two)</i>	1011603	10ME4
	10103734	2"	1001806 <i>(Quantity of Two)</i>	1011604	10ME5

AIRFLOW SHUTOFF KITS – HAMMERLOCK FITTINGS					
	Part Numbers	Pipe String I.D.	Close Nipple	Full Port Ball Valve	Coupling Spud
	10103830	1"	10102151 <i>(Quantity of Two)</i>	1011601	10DXGB13
	10103831	1-1/4"	1011201 <i>(Quantity of Two)</i>	1011602	10DXGB18
	10103832	1-1/2"	1014015 <i>(Quantity of Two)</i>	1011603	10DXGB23
	10103833	2"	1001806 <i>(Quantity of Two)</i>	1011604	10DXGB28
	10103934	3"	10101040 <i>(Quantity of Two)</i>	1011608	10GB38

OPTIONAL ACCESSORIES

Part Numbers		INLET/OUTLET BUSHING
		Size
	10101183	Galvanized 3" MNPT x 2" FNPT Bushing

Part Numbers		GALVANIZED SQUARE HEAD PIPE PLUGS
		Size
	1011901	1"
	1011902	1-1/4"
	1011101	1-1/2"
	1011823	2"
	10101034	3"

Part Numbers	LUBRICATION
1070517	Pneumatic Air Tool Oil - 32 oz. bottle

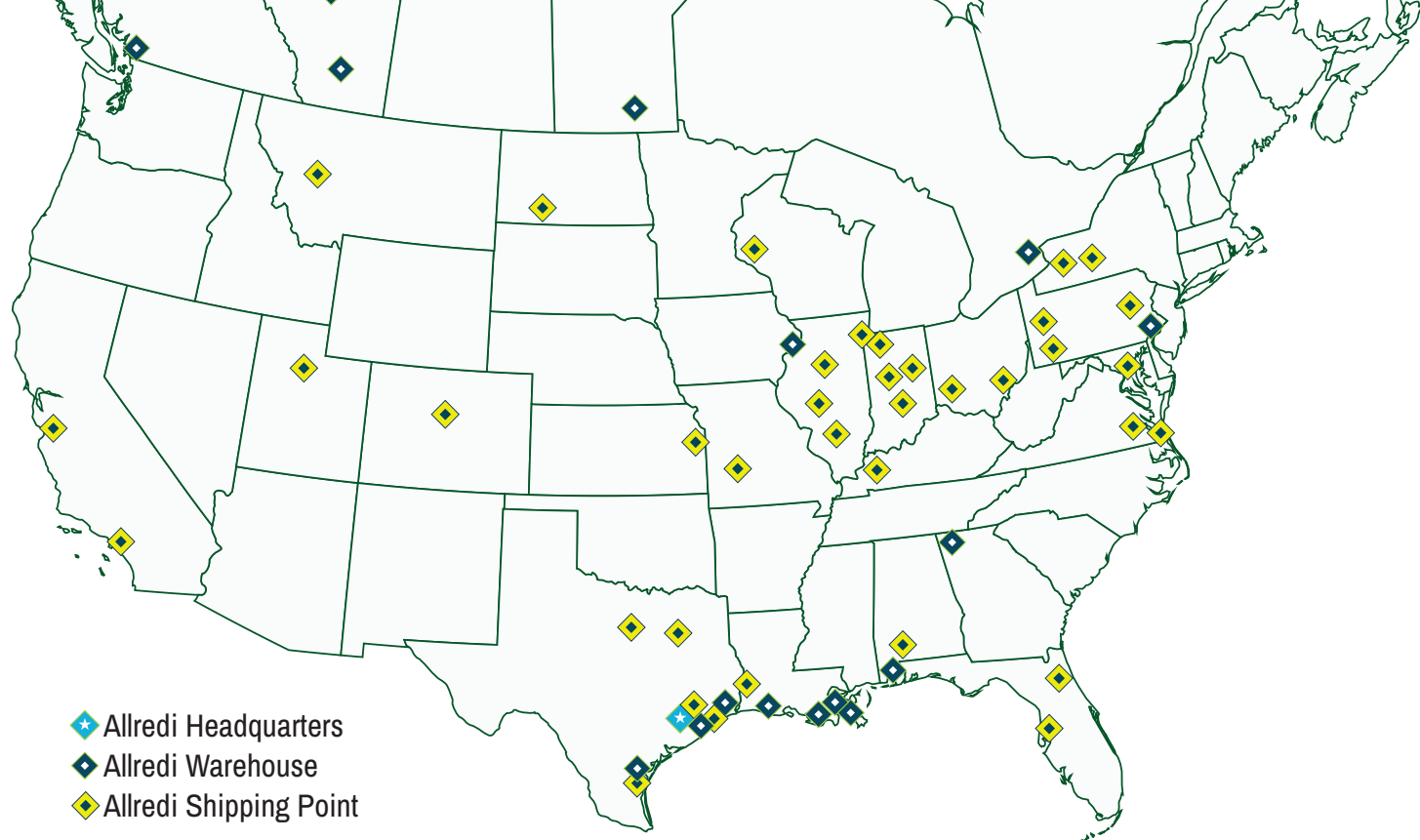

ALLREDI THERE

Serving these industries: Bridge, Pipeline, Tank & Tower, Concrete Services, Rail, Shipyard & Marine, Pools & Fountains, and Foundry

UNITED STATES

Pasadena, TX (*Headquarters*)
844.361.7038

Beaumont, TX
409.722.1284

Bristol, PA
215.826.8080

Corpus Christi, TX
361.887.2038

Davenport, IA
563.324.2519

Deer Park, TX
(*Service & Rental Location*)
281.930.0905

Duluth, GA
800.535.4564

Gonzales, LA
225.647.7575

Harvey, LA
504.367.8090

Houma, LA
985.580.4273

Lafayette, LA
337.267.1440

Theodore, AL
251.338.7525

CANADA

Calgary, Alberta
403.279.1924

Coquitlam, BC
604.464.6979

Edmonton, Alberta
780.468.2588 (Manus)
780.425.5510 (Mod-U-Blast)

Hamilton, Ontario
905.527.6000 / 888.794.5665

Mississauga, Ontario
905.890.5837

Winnipeg, Manitoba
204.256.3324

WWW.ALLREDI-US.COM / 800.252.7848

WWW.ALLREDI-CA.COM / 800.661.3842

Allredi™ and Marco® are registered trademarks of Allredi, LLC.
Mod-U-Blast® is a registered trademark of Allredi Blast & Abrasives Canada, Inc.
All other brand names or marks are used for identification purposes and are trademarks of their respective owners.

ALLREDI™

Literature #106M117_5/13/2024