



GRACO® XTR™ 7 AIRLESS SPRAY GUNS



PART NUMBERS AND SCHEMATICS GUIDE

Company Profile

Allredi was formed in the early 2020, when two of the largest distributors in the blasting, coating, safety, and environmental industry, APE Companies and Marco Group International, joined forces. While the qualities both companies are known for have not changed, a lot about our business is new. New abilities. New agilities. New ways to help you win. This calls for a new name, Allredi.

This name exemplifies what we have become. It is completely oriented to the needs of our customers. To your needs. It says that when you call us for anything – products, service, expert advice, anything – you can consider it done. Or even better, Allredi done.

We are your right-now supplier. From skills to SKUs, we deliver the goods fast. So you can be more agile every minute, every day. This is who we are. This is what our new name means. Go ahead and expect excellence, because we're bringing it.

Our Mission and Vision

To be the industry's preferred partner in surface preparation solutions through unrivaled technical expertise, customer experience, product availability, and tailored service offerings.

The Allredi Difference







- **Industry Experience** – With Allredi on your team, you have access to expertise which can only come from decades of industry leadership. We have organized our engineering department, production specialists, customer operations, and safety support into a "Center of Competence." As an Allredi customer, you have access to hundreds of years of cumulative experience related to your operations.
- **Manufacturing Excellence** – Allredi is a U.S. based manufacturer of equipment for the Surface Preparation and Protective Coatings industries. Allredi's engineers benchmark the industry to ensure that we design and manufacture superior products that set the "Gold Standard" for performance, safety, and quality.
- **Legendary Customer Service** – Allredi's legendary customer service team is staffed by friendly, highly-trained individuals who are focused on providing the highest level of product support, order accuracy, and customer satisfaction.
- **Product Availability** – We stock over 10,000 SKU's and have over 45 shipping locations to serve North American and International markets for all major brands of blasting, coating, environmental, and safety equipment. Allredi is your right-now supplier, so you can keep your projects moving. From our foundation of strong relationships, we have built a nationwide network that puts vast inventory and ready service close to our customers. We provide advanced expertise, and we deliver the goods fast – so you can easily access the products and services you need to me more agile every minute, every day.
- **Technology Leadership** – Our website provides: Operator's Manuals, Part Numbers and Schematics Guides, SDS information, and key product features and specifications, providing access to information 24/7.

TABLE OF CONTENTS





Company Profile	2
Part Numbers	4
Graco® XTR™ 7 Airless Spray Guns	4
Tip Guard Summary	5
Tip Specification Summary	5
XHD™ RAC® Switchtip Specifications	6
Silver Flat Tip Specifications	7
Tip Brushes	7
Tip Gaskets	8
Tip Extensions	8
Mesh Gun Filters	9
Tip Filters	9
Part Numbers And Schematics Guide	10
Graco® Xtr™ 7 Airless Spray Gun	10



PART NUMBERS

GRACO® XTR™ 7 AIRLESS SPRAY GUNS

	Part Numbers	Trigger Style	Tip	Handle Style	Tip Guard	Maximum Working Pressure
	20GXTR723	2-Finger	XHD™ 519 RAC® Tip	Oval	XHD™ RAC®	7,250 psi
	20GXTR725	2-Finger	XHD™ 519 RAC® Tip	Round	XHD™ RAC®	7,250 psi
	20GXTR720	4-Finger	None	Round	7/8" Flat Guard	7,250 psi
	20GXTR722	4-Finger	XHD™ 519 RAC® Tip	Oval	XHD™ RAC®	7,250 psi
	20GXTR724	4-Finger	XHD™ 519 RAC® Tip	Round	XHD™ RAC®	7,250 psi
	20GXTR721	4-Finger	519 Silver Flat Tip	Round	7/8" Flat Guard	7,250 psi

PART NUMBERS

		TIP GUARD SUMMARY		
	Part Numbers	Tip Style	Thread Size	Color
	20GXHD001	XHD™ RAC®	7/8 Inch	Gray
	20GXHD003	XHD™ RAC®	7/8 Inch	Gray
	20G220251	Flat	7/8 Inch	Orange
	20G220255	Flat	11/16 Inch	Orange
	20GXHD005	XHD™ RAC™	11/16 Inch	Gray

		TIP SPECIFICATION SUMMARY				
	Part Numbers	Tip Guard	Maximum Working Pressure	Color	Typical Applications	Typical Materials
	XHD RAC® SwitchTip™ (20GXHDxxx)	XHD™ RAC® 20GXHD001 20GXHD003	7250 psi	Gray	Bridges, Tanks, Farms, Structural Steel, or Roofing	Virtually all Paints and Coatings – Solvent and Water-base
	Silver Flat Tip (20G163xxx)	Flat 20G220251 20G220255	5000 psi	N/A	Residential, Commercial, or Industrial	Architectural Coatings

PART NUMBERS

		XHD™ RAC® SWITCHTIP SPECIFICATIONS					
Part Numbers		Tip Guard	Maximum Working Pressure	Color	Typical Applications	Typical Materials	
	XHD™ RAC® SwitchTip™ (20GXHDxxx)	XHD™ RAC 20GXHD001 20GXHD003	7250 psi	Gray	Bridges, Tanks, Farms, Structural Steel, or Roofing	Virtually all Paints and Coatings – Solvent and Water-base	

XHD™ RAC® SwitchTips™ (20GXHDxxx)

		ORIFICE SIZE – INCHES																		
FAN WIDTH		IN	.007	.009	.011	.013	.015	.017	.019	.021	.023	.025	.027	.029	.031	.033	.035	.037	.039	.041
	2-4		107	109	111	113	115	117	119	121									139	
	4-6			209	211	213	215	217	219	221		225	227	229	231		235		239	
	6-8		307	309	311	313	315	317	319	321	323	325	327	329	331	333	335	337	339	341
	8-10			409	411	413	415	417	419	421	423	425	427	429	431	433	435	437	439	441
	10-12			509	511	513	515	517	519	521	523	525	527	529	531	533	535	537	539	541
	12-14			609	611	613	615	617	619	621	623	625	627	629	631	633	635	637	639	641
	14-16				711	713	715	717	719	721	723	725	727	729	731	733	735	737	739	741
	16-18					813	815	817	819	821	823	825	827	829	831	833	835	837	839	841
	18-20										923		927		931	933	935	937	939	
	Flow Rate (gpm)		.05	.09	.12	.18	.24	.31	.38	.47	.57	.67	.77	.90	1.03	1.17	1.31	1.47	1.63	1.8

XHD™ RAC® SwitchTips™ (20GXHDxxx) continued

		ORIFICE SIZE – INCHES																		
FAN WIDTH		IN	.043	.045	.047	.047	.051	.053	.055	.057	.059	.061	.063	.065	.067	.069	.071	.075	.081	
	2-4																			
	4-6																			
	6-8		343	345	347		351		355											
	8-10		443	445	447	449	451		455		459	461	463	465	467		471	475	481	
	10-12		543	545	547	549	551	553	555	557		561		565	567		571	575		
	12-14		643	645	647	649	651		655	657	659	661	663	665	667	669	671	675		
	14-16		743		747	749	751	753	755			761			767		771			
	16-18		843		847		851		855			861	863		867					
	18-20																			
	Flow Rate (gpm)		1.98	2.17	2.37	2.58	2.79	3.05	3.25	3.49	3.74	4.0	4.26	4.53	4.82	5.11	5.41	6.04	7.04	

PART NUMBERS



SILVER FLAT TIP SPECIFICATIONS

	Part Numbers	Tip Guard	Maximum Working Pressure	Color	Typical Applications	Typical Materials
	Silver Flat Tip (20G163xxx)	Flat 20G220251 20G220255	5000 psi	N/A	Residential, Commercial, or Industrial	Architectural Coatings





Silver Flat Tips (20G163xxx)





		ORIFICE SIZE – INCHES												
		IN	.011	.013	.015	.017	.019	.021	.023	.025	.027	.029	.031	.035
FAN WIDTH	4-6	211	213	215	217	219				225	227			
	6-8	311	313	315	317	319	321	323	325	327				
	8-10	411	413	415	417	419	421	423	425	427				435
	10-12	511	513	515	517	519	521	523	525	527			531	
	12-14		613	615	617	619	621	623	625	627			631	635
	14-16			715	717	719	721		725					
	16-18			815		819	821				827	829	831	
	18-20									925				
	Flow Rate (gpm)		.12	.18	.24	.31	.38	.47	.57	.67	.74	.90	1.03	1.31

TIP BRUSHES





	Part Numbers	Size	Bristle Material
	20G101891	3/8 x 2-1/4 Inches	Nylon
	20G101892	5/8 x 2-1/4 Inches	Nylon
	20G119799	3/8 x 1 Inch	Nylon



PART NUMBERS

		TIP GASKETS		
Part Numbers		Description	Material	Package Quantity
	20G166969	1/16 Inch Thin Tip Gasket	Nylon	One Each
	20G223373	1/16 Inch Thin Tip Gaskets	Nylon	25/Package
	20G162863	5/32 Inch Thick Tip Gasket	Nylon	One Each
	20G223374	5/32 Inch Thick Tip Gaskets	Nylon	25/Package

		TIP EXTENSIONS		
Part Numbers		Description		Package Quantity
	20G246294	Heavy-Duty 10 Inch Tip Extension		One Each
	20G246295	Heavy-Duty 15 Inch Tip Extension		One Each
	20G246296	Heavy-Duty 18 Inch Tip Extension		One Each
	20G246297	High Pressure 180° Swivel		One Each

PART NUMBERS

		MESH GUN FILTERS		
Part Numbers		Mesh Size	Color	Package Quantity
	20G287032	60 Mesh	Black	1/Package
	20G287033	100 Mesh	Blue	1/Package
	20G287034	60 Mesh and 100 Mesh	Black and Blue	1 Each/Package
	20G224455	100 Mesh	Silver	2/Package
	20G224456	50 Mesh	Silver	2/Package

		TIP FILTERS	
Part Numbers		Mesh Size	Package Quantity
	20G224453	60 Mesh	5/Package
	20G224454	100 Mesh	5/Package

PART NUMBERS AND SCHEMATICS GUIDE

Graco® XTR™ 7 Airless Spray Gun

Item #	Part #	Description	XTR720	XTR721	XTR722	XTR723	XTR724	XTR725
Fig. 1								
1	20G15E178	Body, Gun	X	X	X	X	X	X
2*	20G245881	Seal, Retainer Assembly	X	X	X	X	X	X
3*	---	Gasket	X	X	X	X	X	X
4	20G15A864	Cap, end	X	X	X	X	X	X
5	20G117350	Spring	X	X	X	X	X	X
6	20G15E088	Retainer, needle	X	X	X	X	X	X
7	20G15E085	Pin, acuator	X	X	X	X	X	X
8*	20G248591	Needle	X	X	X	X	X	X
9*	20G156766	Gasket	X	X	X	X	X	X
10*	20G245858	Seat, Valve	X	X	X	X	X	X
14	20G248952	Handle, Kit	X	X			X	X
15	20G276997	Handle Sleeve, oval, insulated			X	X		
	20G15E083	Handle Sleeve, round	X	X			X	X
16	20G287449	Trigger Kit, (4-Finger, straight, includes 16b)	X	X			X	
	20G287451	Trigger Kit, (4-Finger, curved, includes 16b)			X			
	20G287450	Trigger Kit, (2-Finger, includes 16a and 16b)				X		X
16a	20G192272	Pin, pivot	X	X	X	X	X	X
16b	20G203953	Screw, cap, #10-24	X	X	X	X	X	X
19	20GXHD001	Guard, RAC Tip	X		X	X	X	X
20	20GXHDxxx	Switch, RAC tip; 519 size included			X	X	X	X
	20GXHDxxx	Switch, RAC tip; 519 size						
20a	---	Seal, fluid			X	X	X	X
20b	---	Gasket			X	X	X	X
20c	---	Tip, Spray, XHD RAC			X	X	X	X
21*	20G179733	Seal, sleeve	X	X	X	X	X	X
24	20G119740	O-Ring			X	X		
26	20G287032	Filter, 60 mesh included with gun	X	X	X	X	X	X
	20G287034	Filter, 60 mesh and 100 mesh combo	X	X	X	X	X	X
29	20G222385	Tag, warning (<i>not shown</i>)	X	X	X	X	X	X
30	20G166969	Gasket		X				
31	20G220251	Guard, Flat Tip		X				
32	20G163519	Tip, Flat		X				
36*	20G194744	Tool, repair, packing	X	X	X	X	X	X
—	206M511	Part Numbers & Schematics Guide – Graco XTR™ 7 Airless Spray Guns						
—	209V511	Operators Manual – Graco XTR™ 7 Airless Spray Guns						

--- Item not available for individual sale

* Parts included in Repair Kit 20G248837 purchased separately

PART NUMBERS AND SCHEMATICS GUIDE

Figure 1: Graco® XTR™ 7 Airless Spray Gun

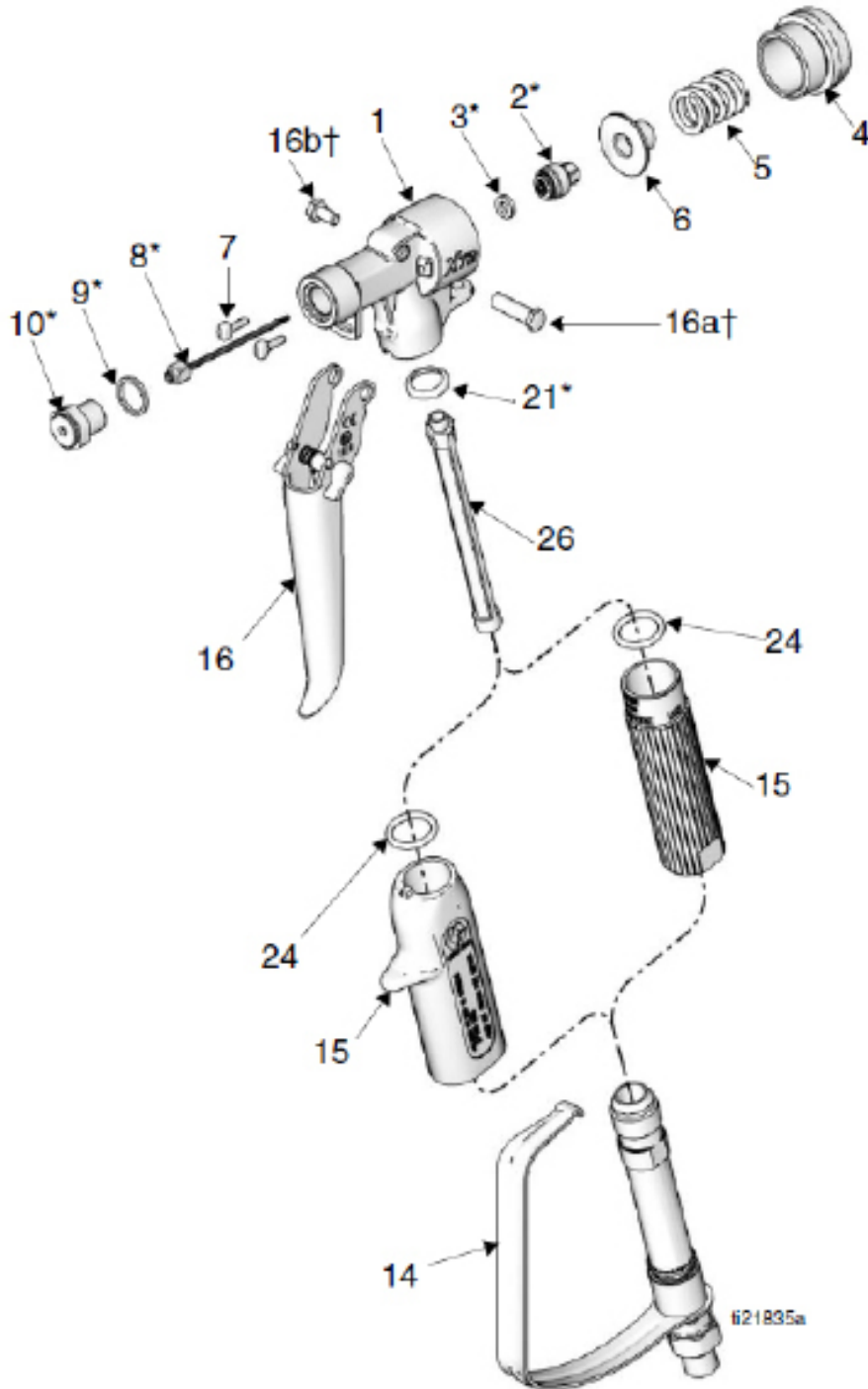



ALLREDI THERE

Serving these industries: Bridge, Pipeline, Tank & Tower, Concrete Services, Rail, Shipyard & Marine, Pools & Fountains and Foundry

UNITED STATES

Pasadena, TX (*Headquarters*)
844.361.7038

Beaumont, TX
409.722.1284

Bristol, PA
215.826.8080

Corpus Christi, TX
361.887.2038

Davenport, IA
563.324.2519

Deer Park, TX
(*Service & Rental Location*)
281.930.0905

Duluth, GA
800.535.4564

Gonzales, LA
225.647.7575

Harvey, LA
504.367.8090

Houma, LA
985.580.4273

Jacksonville, FL
904.262.2120

Lafayette, LA
337.267.1440

Theodore, AL
251.338.7525

Youngstown, OH
330.448.6267

CANADA

Calgary, Alberta
403.279.1924

Coquitlam, BC
604.464.6979

Edmonton, Alberta
780.468.2588 (Manus)
780.425.5510 (Mod-U-Blast)

Hamilton, Ontario
905.527.6000 / 888.794.5665

Mississauga, Ontario
905.890.5837

Winnipeg, Manitoba
204.256.3324

800-252-7848 / WWW.ALLREDI-US.COM

Allredi™ and Marco® are registered trademarks of Allredi, LLC.
All other brand names or marks are used for identification purposes and are trademarks of their respective owners.

ALLREDI™
Literature #206M511_6/23/2022