

Xtreme™ Lowers

311762W

EN

High volume lowers for protective coatings. For professional use only.

See page 3 for model information, see page 33 for maximum working pressure.



Important Safety Instructions

Read all warnings and instructions in this manual.
Save these instructions.

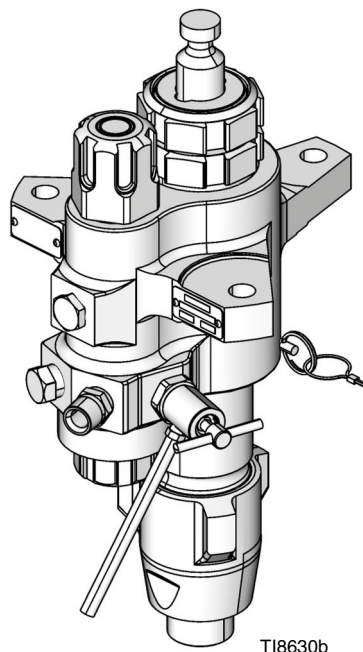

T18630b

Model L220C2 Lower with Built-in Filter

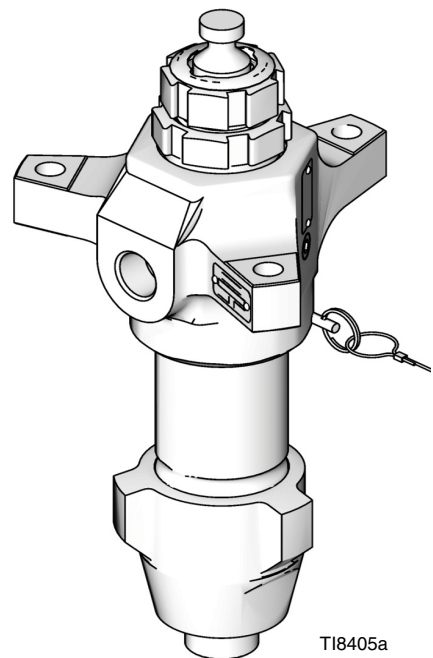

T18405a

Model L220C1 Lower without Filter

Contents

Related Manuals 2

Models 3

Warnings 4

Component Identification 6

Repair 7

 Disassembly 7

 Service Built-in Filter 14

Parts 16

Repair Kits 26

 Xtreme Seals™ Repair Kits 26

 Tuff-Stack™ Repair Kits 27

 X-Tuff® Repair Kits 28

Kits 29

Dimensions 31

Outlet Housing Mounting Hole Layout 32

Technical Data 33

Graco Standard Warranty 36

Graco Information 36

Related Manuals

Component Manuals in English:

Manual	Description
311164	Xtreme Packages Instructions and Parts
3A0420	XP Sprayer Operation
311238	NXT® Air Motor Instructions and Parts
311239	Air Control Modules for NXT Air Motors Instructions and Parts
Xtreme Lower Repair Kits	
406882	Filter Seal and Cap Conversion Kit, Instructions-Parts
406879	XP 36cc Lower, Repair-Parts
406880	XP 48cc Lower, Repair-Parts
406990	XP 54cc Lower, Repair-Parts
406881	XP 58cc Lower, Repair-Parts
406991	XP 72cc Lower, Repair-Parts
406888	XP/Xtreme 85cc Lower, Repair-Parts
406992	XP 90cc Lower, Repair-Parts
406993	XP 97cc Lower, Repair-Parts
406889	XP/Xtreme 115cc Lower, Repair-Parts
406890	XP/Xtreme 145cc Lower, Repair-Parts
406891	XP/Xtreme 180c Lower, Repair-Parts
406892	XP/Xtreme 220cc Lower, Repair-Parts
406893	XP/Xtreme 250cc Lower, Repair-Parts
406894	XP/Xtreme 290cc Lower, Repair-Parts

Models

Check the identification plate (ID) on your lower for the 6-digit part number of your lower. Use the following matrix to define the construction of your lower, based on the six digits. For example, Lower Part Number **L180C1** represents the lower (**L**), output volume (**180**), carbon steel construction (**C**), and no filter with Xtreme Seal™ packing stack (**1**).

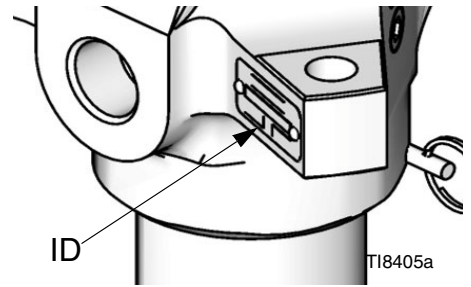

To order replacement parts, see **Parts**, starting on page 16.

 For maximum fluid working pressures, see **Technical Data** section starting on page 33.

L	180	C	1					
First Digit	Second, Third, and Fourth Digits	Fifth Digit		Sixth Digit				
	Lower Volume (cc)		Material	Integrated Filter	Xtreme Seal™ Packing Set*	Tuff Stack™ Packing Set*	X-Tuff® Packing Set*	
L (lower)	36★	C	Carbon Steel	0☼	✓			✓
	48★			1		✓		
	54★			2	✓	✓		
	58★			3			✓	
	72★			4	✓		✓	
	85★			7				✓
	90★			8†		✓		
	97★			9†				✓
	115★							
	145							
	14A★							
	180							
	18A★							
	220							
	22A★							
	250							
	25A★							
	290							
	29A★							





- ★ Models with a 5.9 in. bolt pattern; see page 32.
- ☼ XP proportioner models with inlet spring and no purge valve.
- * See **Repair Kits**, page 26, for packing material details.
- † Includes rupture disc.





Part No.	Description	Packings
24N942	290 Xtreme carbon steel, with hard chrome rod	X-Tuff Packing Set

 Not all options are available in all sizes.

Warnings

The following warnings are for the setup, use, grounding, maintenance, and repair of this equipment. The exclamation point symbol alerts you to a general warning and the hazard symbol refers to procedure-specific risk. Refer back to these warnings. Additional, product-specific warnings may be found throughout the body of this manual where applicable.

 WARNING	
	<p>FIRE AND EXPLOSION HAZARD</p> <p>Flammable fumes, such as solvent and paint fumes, in work area can ignite or explode. To help prevent fire and explosion:</p> <ul style="list-style-type: none"> • Use equipment only in well ventilated area. • Eliminate all ignition sources; such as pilot lights, cigarettes, portable electric lamps, and plastic drop cloths (potential static arc). • Keep work area free of debris, including solvent, rags and gasoline. • Do not plug or unplug power cords, or turn power or light switches on or off when flammable fumes are present. • Ground all equipment in the work area. See Grounding instructions. • Use only grounded hoses. • Hold gun firmly to side of grounded pail when triggering into pail. • If there is static sparking or you feel a shock, stop operation immediately. Do not use equipment until you identify and correct the problem. • Keep a working fire extinguisher in the work area.
	<p>SKIN INJECTION HAZARD</p> <p>High-pressure fluid from gun, hose leaks, or ruptured components will pierce skin. This may look like just a cut, but it is a serious injury that can result in amputation. Get immediate surgical treatment.</p> <ul style="list-style-type: none"> • Do not point gun at anyone or at any part of the body. • Do not put your hand over the spray tip. • Do not stop or deflect leaks with your hand, body, glove, or rag. • Do not spray without tip guard and trigger guard installed. • Engage trigger lock when not spraying. • Follow Pressure Relief Procedure in manual 311164, when you stop spraying and before cleaning, checking, or servicing equipment.
	<p>EQUIPMENT MISUSE HAZARD</p> <p>Misuse can cause death or serious injury.</p> <ul style="list-style-type: none"> • Do not operate the unit when fatigued or under the influence of drugs or alcohol. • Do not exceed the maximum working pressure or temperature rating of the lowest rated system component. See Technical Data in all equipment manuals. • Use fluids and solvents that are compatible with equipment wetted parts. See Technical Data in all equipment manuals. Read fluid and solvent manufacturer's warnings. For complete information about your material, request MSDS forms from distributor or retailer. • Check equipment daily. Repair or replace worn or damaged parts immediately with genuine manufacturer's replacement parts only. • Do not alter or modify equipment. • Use equipment only for its intended purpose. Call your distributor for information. • Route hoses and cables away from traffic areas, sharp edges, moving parts, and hot surfaces. • Do not kink or over bend hoses or use hoses to pull equipment. • Keep children and animals away from work area. • Comply with all applicable safety regulations.

 WARNING	
 	<p>MOVING PARTS HAZARD</p> <p>Moving parts can pinch or amputate fingers and other body parts.</p> <ul style="list-style-type: none"> • Keep clear of moving parts. • Do not operate equipment with protective guards or covers removed. • Pressurized equipment can start without warning. Before checking, moving, or servicing equipment, follow the Pressure Relief Procedure in manual 311164. Disconnect power or air supply.
	<p>TOXIC FLUID OR FUMES HAZARD</p> <p>Toxic fluids or fumes can cause serious injury or death if splashed in the eyes or on skin, inhaled, or swallowed.</p> <ul style="list-style-type: none"> • Read MSDS's to know the specific hazards of the fluids you are using. • Store hazardous fluid in approved containers, and dispose of it according to applicable guidelines. • Always wear impervious gloves when spraying or cleaning equipment.
	<p>PERSONAL PROTECTIVE EQUIPMENT</p> <p>You must wear appropriate protective equipment when operating, servicing, or when in the operating area of the equipment to help protect you from serious injury, including eye injury, inhalation of toxic fumes, burns, and hearing loss. This equipment includes but is not limited to:</p> <ul style="list-style-type: none"> • Protective eyewear • Clothing and respirator as recommended by the fluid and solvent manufacturer • Gloves • Hearing protection

Component Identification

(Shown with Built-in Filter)

XP Sprayer Xtreme Lowers

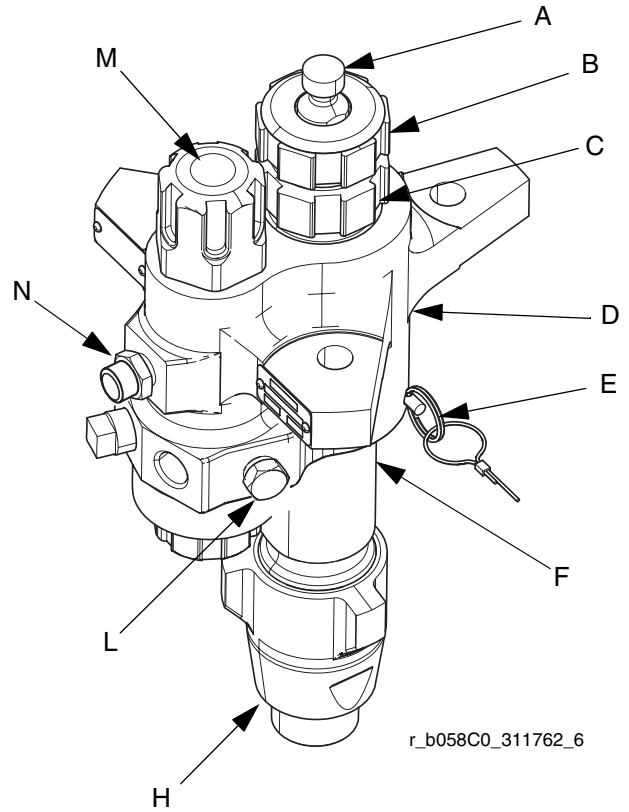
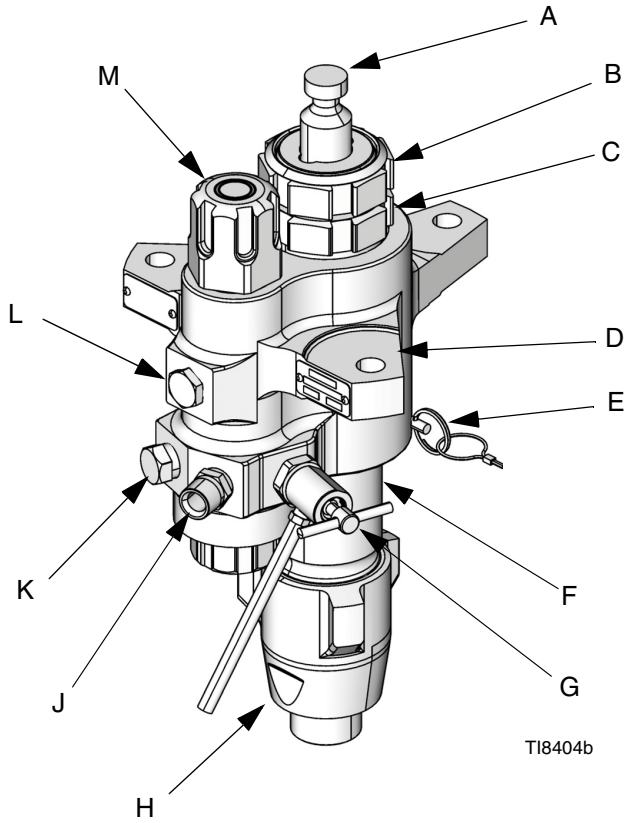

Key:

- A Displacement Rod
- B Packing Nut
- C Throat Cartridge
- D Outlet Housing
- E Locking Pin
- F Cylinder
- G Drain/Purge Valve (not on XP Lowers)

- H Inlet Housing
- J Fluid Outlet
- K Optional Fluid Outlet (for second spray gun; not on XP Lowers)
- L Pipe Plug (non-filtered outlet)
- M Fluid Filter
- N Over Pressure Rupture Disc (for 36cc, 48cc, 54cc, 58 cc, and 72cc only)

Repair

Required Tools

- Set of adjustable wrenches
- Torque wrench
- Rubber mallet
- Arbor press
- Soft wooden block (approx. 1 square ft in size)
- Large vise with soft jaws
- Thread lubricant
- Petroleum jelly
- Anti-seize lubricant

Disassembly

Layout all removed parts in sequence to ease reassembly. Clean all parts with a compatible solvent and inspect them for wear or damage.

 Repair kits are available to replace the throat (3) and piston (4) packings, and to replace the o-rings and cylinder seals. For best results, use all new parts in the kit. Kit parts are marked with an asterisk, for example (25*). These kits can also be used to convert the lower to different packing materials. See the Packing Kits sections.

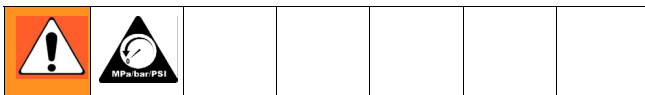

1. Relieve pressure. See your Xtreme Packages manual (311164) for instructions.
2. Disconnect lower from motor as illustrated in your Xtreme Packages manual (311164). Or, if you have a cart mounted system, tip cart up to service lower on cart.

3. For lowers with built-in filters, loosen and remove both top filter cap (20) and bottom filter cap (26). See **Service Built-in Filter**, page 14.

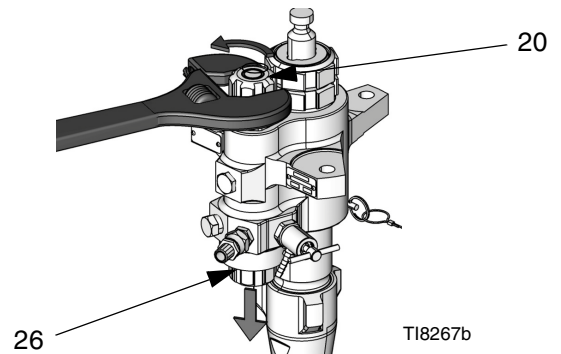

4. Loosen and remove inlet housing (14) from lower cylinder (11).

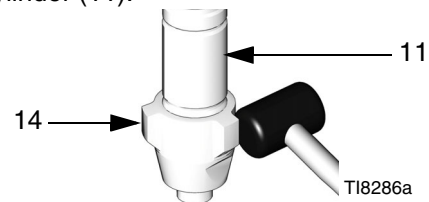

5. Press inlet ball (16) out from bottom of inlet housing (14) (take care not to damage seat (18) to remove entire inlet ball guide assembly).

 On model L180C7 only, shims (17) will be below inlet ball guide (15).

- a. *For Xtreme Lowers:* Remove inlet ball, bottom o-ring (27*), and seat. Then remove remaining o-rings from top and bottom grooves of inlet ball guide (15).

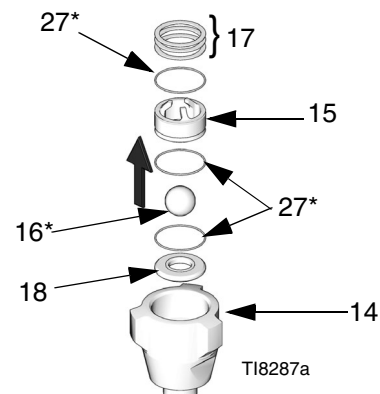

FIG. 1:

- b. For 115 and smaller XP Lowers: Remove spring, inlet ball, bottom o-ring, and shims. Then remove remaining o-rings from top and bottom grooves of inlet ball guide (15).

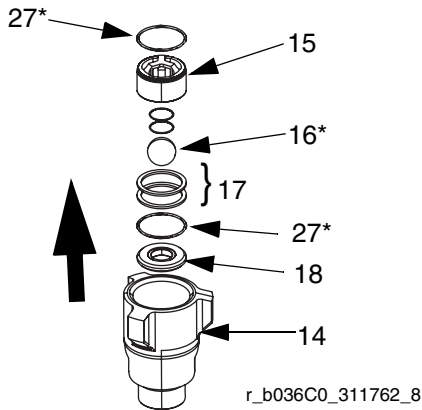

FIG. 2

- c. For 145cc and larger XP Lowers: Remove inlet ball, bottom o-ring, and shim. Then remove remaining o-rings from top and bottom grooves of inlet ball guide (15).

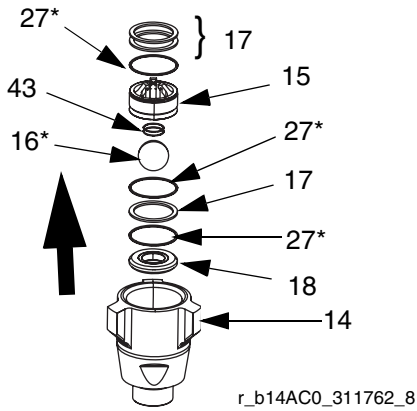
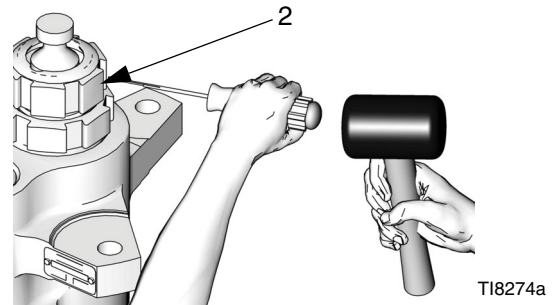
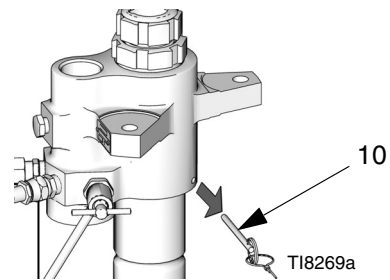

FIG. 3

6. Stand lower upright in large vise. Using a rubber mallet, loosen, but do not remove packing nut (2).



7. Remove locking pin (10) from lower cylinder (11).



8. Unscrew and lift outlet housing (8) straight up off cylinder. Be careful not to scratch displacement rod (1).

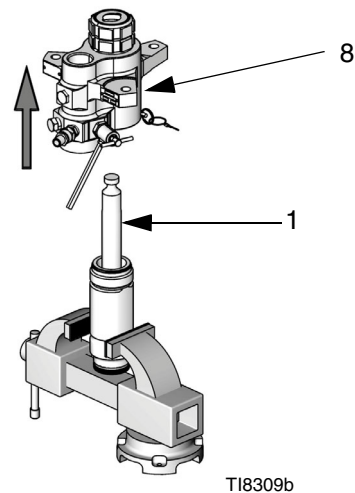

9. Remove cartridge assembly. Remove o-ring (27* or 29*) from bottom of outlet housing (8), and then unscrew packing nut (2) from packing cartridge (7). Remove female gland, male gland, and v-packings (3) from packing cartridge (7).

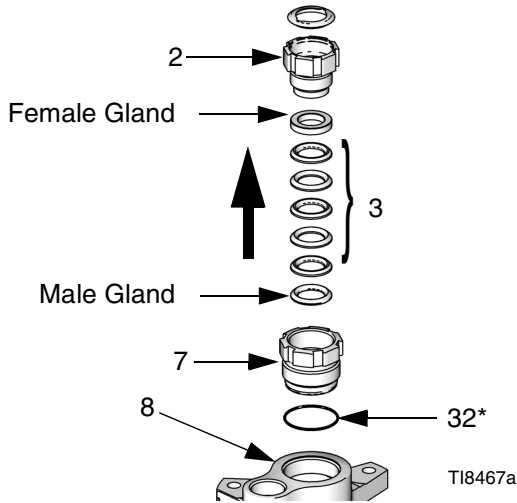

NOTICE

To reduce the possibility of costly damage to displacement rod (1) and lower cylinder (11), first place lower cylinder on a soft block of wood. Always use a rubber mallet or an arbor press to drive the displacement rod out of the lower cylinder. Never use a hammer to drive the rod out. Damage to the rod end will shorten pump life.

10. Stand lower cylinder (11) upright on a wooden block. Using a rubber mallet or an arbor press, drive displacement rod (1) out of the bottom until the piston comes free. Pull the rod and piston from the cylinder, being careful not to scratch the rod or cylinder.

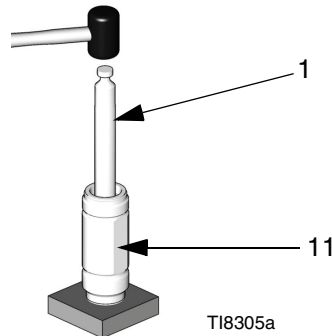

11. Inspect outer surface of displacement rod (1) and inner surface of lower cylinder (11) for scoring or wear; replace if damaged.

12. Put flats of piston valve (13) in a vise. Use a wrench to loosen displacement rod (1) from piston valve.

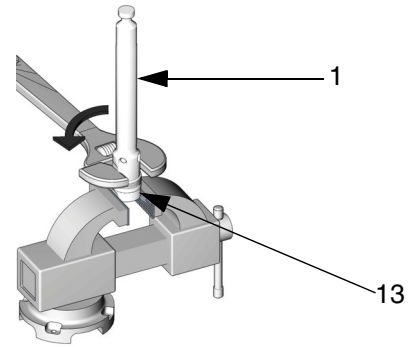

T18298a

13. Remove displacement rod from piston valve. Be careful that piston ball (12*) does not fall as you separate piston valve and rod.

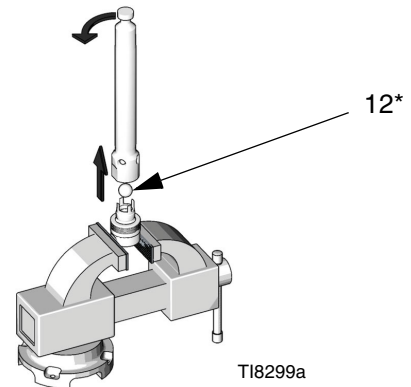

T18299a

14. Remove glands and v-packings (4) from piston valve (13). Inspect piston ball (12*) and piston valve for wear or damage.

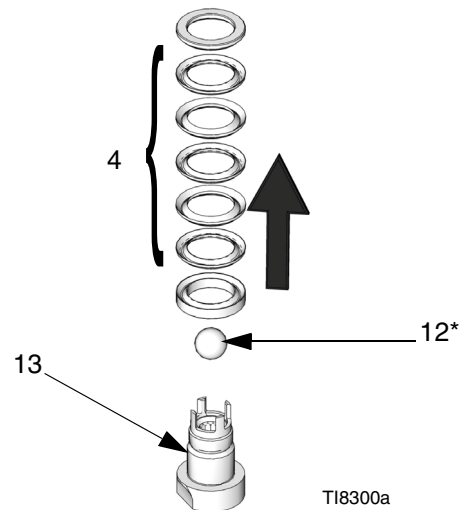



T18300a

15. Clean all parts with a compatible solvent.

Reassembly

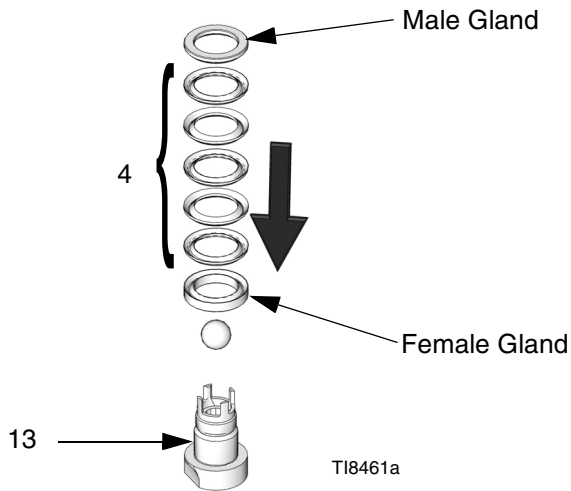
1. Replace female gland on piston valve (13). Install the five v-packings (4) one at a time with lips facing up. Refer to the Packing Kits sections for the correct packing order for your lower. Install the male gland.



 To convert the lower to a different packing material, see the Packing Kits sections.

For best results, soak leather packings in oil before reassembly.

2. Ensure there are no burrs or debris on mating threads of displacement rod (1) and piston valve (13). Apply anti-seize lubricant to threads and mating surfaces of displacement rod and piston valve.

3. Place flats of piston valve in a vise. Place piston ball (12*) on piston valve.

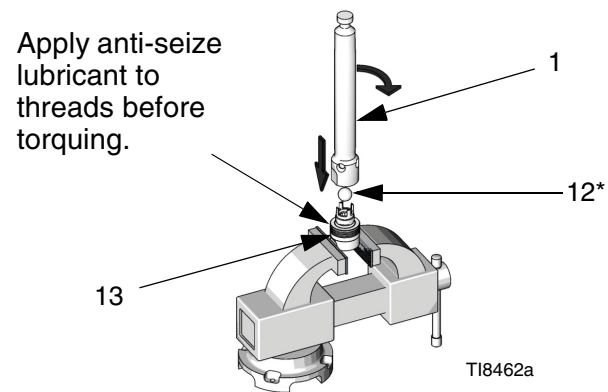

4. Screw displacement rod (1) onto piston valve (13), and hand tight. Then torque per table on page 13.

 Orient crowfoot of torque wrench at a 90° angle to ensure accurate torque values.

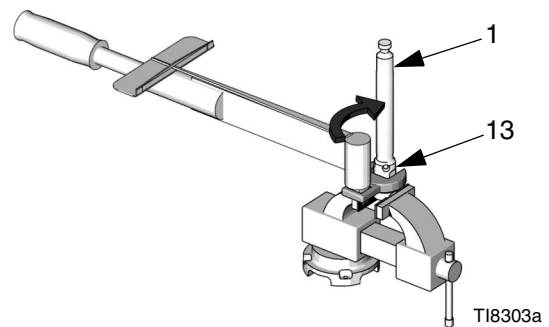

NOTICE

To reduce the possibility of costly damage to displacement rod (1) and lower cylinder (11), first place lower cylinder on a soft block of wood. Always use a rubber mallet or an arbor press to drive the displacement rod into the lower cylinder. Never use a hammer to drive the rod.

- To reinstall displacement rod (1) into lower cylinder (11), first lubricate piston packings (4). Then, with piston end facing down, lower rod into cylinder. Start piston into cylinder as much as possible, then drive rod and piston the rest of the way into the cylinder with an arbor press or rubber mallet.

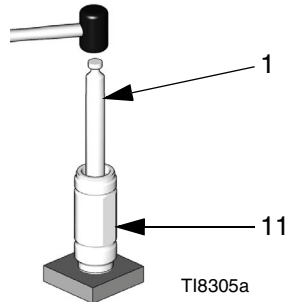

- Lubricate inside of packing cartridge (7), outside threads of packing nut (2), and throat packings (3). Install packing cartridge into housing. Place male gland in packing cartridge. Install the five v-packings one at a time with lips facing down. Refer to the Packing Kits sections for the correct packing order for your lower. Install female gland. Then, reassemble packing nut (2), but do not tighten.

 To convert lower to a different packing material, see Packing Kits sections. For best results, soak leather packings in oil before reassembly.

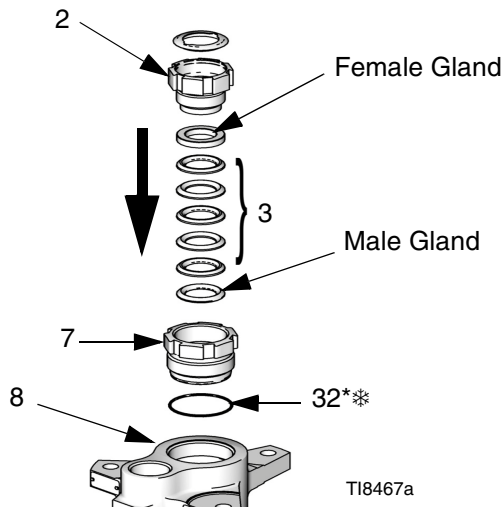

*Blue o-ring for 220cc, 250cc, 290cc lowers.

- Screw lower cylinder (11) onto outlet housing (8) until it bottoms out. Use a wrench to tighten lower cylinder. Back off as little as possible until hole in housing lines up with flat on cylinder. Insert locking pin (10) into cylinder.

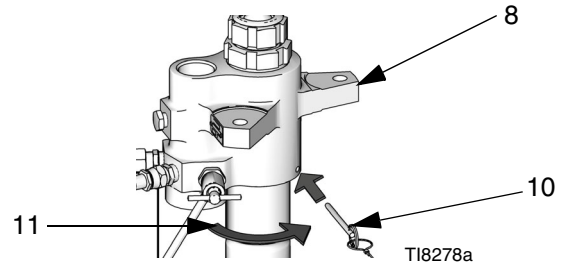

- Assemble inlet housing.

- For 115cc and smaller XP Lowers: Install seat (18), two shims (17), inlet ball (16), spring (43), and one o-ring (27) into inlet housing (14).

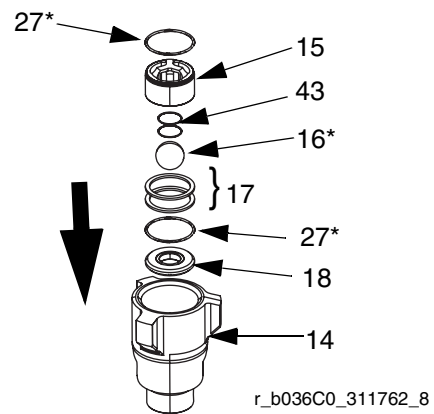

- For 145cc and larger XP Lowers: Install seat (18), shim (17), inlet ball (16), spring (43), and one o-ring (27) into inlet housing (14).

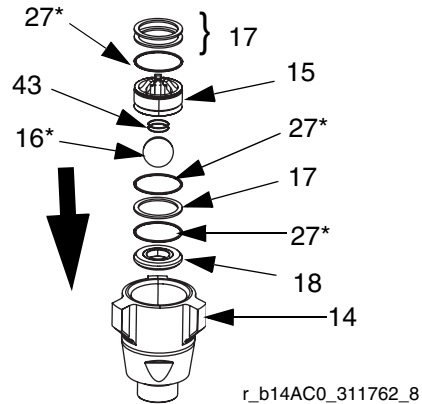

- c. For Xtreme Lowers: Install inlet seat (18), inlet ball (16), and one o-ring (27*) into inlet housing (14).

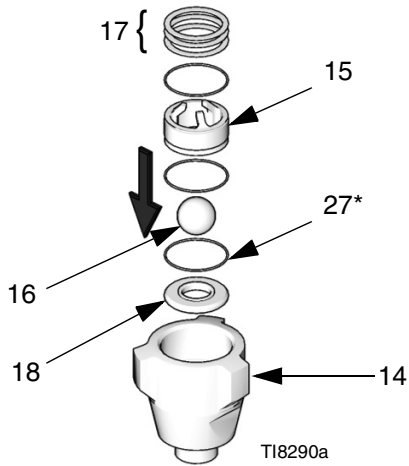

12. Thread inlet housing (14) onto lower cylinder (11). Torque to 140-150 ft-lb (189-203 N•m).

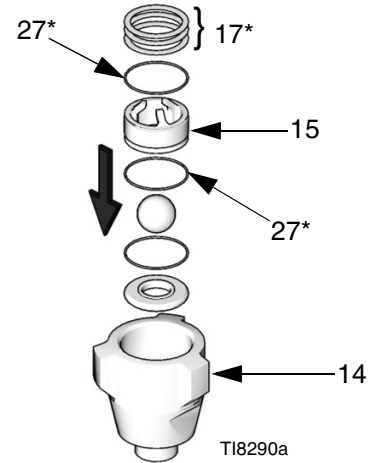

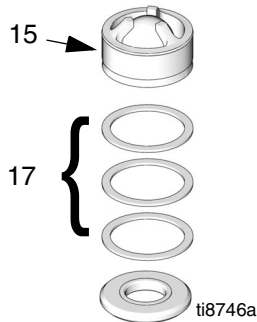

9. Lubricate and install o-rings (27*) in top and bottom grooves of inlet ball guide (15).

10. On model L180C7 only, install shims (17) into inlet housing (14), then press inlet ball guide (15) into inlet housing (14).

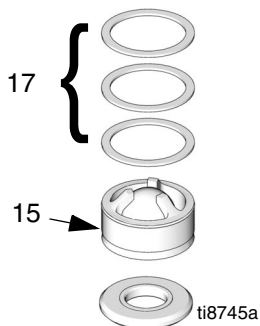

11. On all models except L180C7, press inlet ball guide (15) into inlet housing (14) and install shims (17).



 Shims (three maximum) can be assembled either for short ball travel or long ball travel. See FIG. 4 for an example of each.

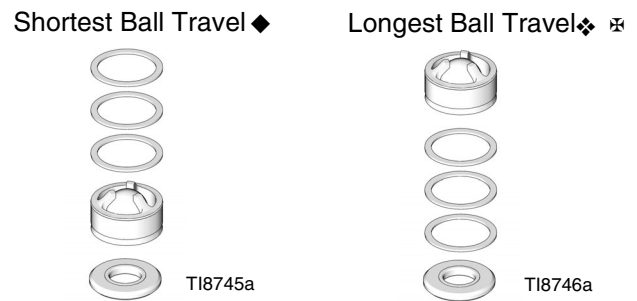

◆ Factory set configuration for optimum pump change over.

❖ Shims can be configured to change ball travel length. Use longer ball travel length for higher viscosity fluids.

⊠ Optional inlet ball spring kit available. Use to improve change over rate with longer ball travel configurations. See **Kits**, page 29, for more information.

FIG. 4: Shim Configuration for lowers without inlet spring

13. Using torque wrench, torque packing cartridge (7) to outlet housing (8). Torque to 140-150 ft-lb (189-203 N•m).
14. Insert packings in correct orientation; see **Parts**, page 16. Install packing nut (2) and torque to the value in the table below.

Required Torque

Pump	Throat Packing (2)	Piston Valve (13)	
L036C0 L048C0 L054C0 L058C0	25-30 ft-lb (34 N•m)	85 ft-lb (114 N•m)	
L072C0 L085C0 L085C1 L085C2	25-30 ft-lb (34 N•m)	125 ft-lb (168 N•m)	
L085C3 L085C4	125 ft-lb (168 N•m)		
L090C0 L097C0 L115C0 L115C1 L115C2	25 ft-lb (34 N•m)		
L115C3 L115C4	125 ft-lb (168 N•m)		
L145C0 L145C1 L145C2 L145C8 L14AC1	25 ft-lb (34 N•m)		
L145C3 L145C4	125 ft-lb (168 N•m)		
L180C0 L180C1 L180C2 L18AC1	25 ft-lb (34 N•m)		
L180C3 L180C4 L180C7 L180C9	125 (168 N•m)		
L220C0 L220C1 L220C2 L22AC1	25 ft-lb (34 N•m)		200 ft-lb (269 N•m)
L220C3 L220C4 L220C9	125 ft-lb (168 N•m)		
L250C0 L250C1 L250C2 L250C8	25 ft-lb (34 N•m)		
L250C3 L250C4 L25AC4	125 ft-lb (168 N•m)		
L290C0 L290C1 L290C2 L29AC1 24N942	25 ft-lb (34 N•m)		
L290C3 L290C4	125 ft-lb (168 N•m)		

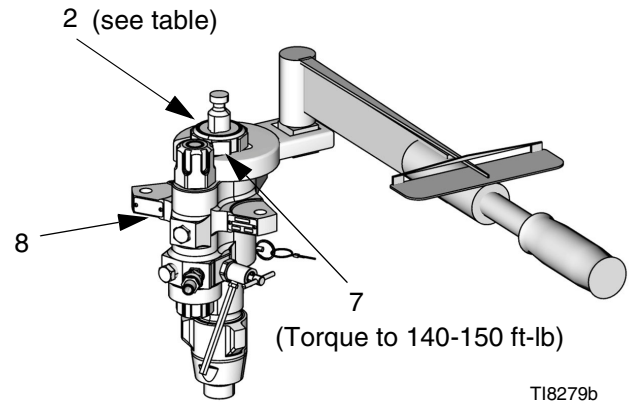

15. For lowers with built-in filter, see **Service Built-in Filter**, page 14, if filter needs service. Then reinstall both top filter cap (20) and bottom filter cap (26).

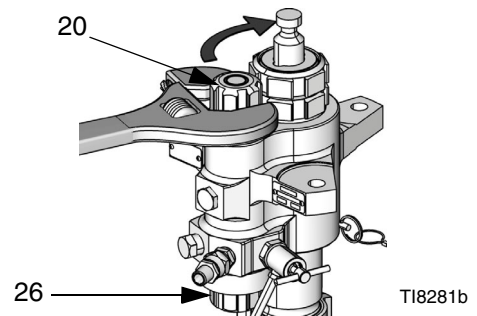

16. Reconnect lower to air motor. See Xtreme Pack-ages manual (311164).

Service Built-in Filter

Select models have a built-in filter in the lower housing.

Disassembly

To remove and clean the built-in filter:

1. Relieve fluid pressure.
 - a. Turn off sprayer motor and any feed pumps.
 - b. Drain all fluid pressure from sprayer. See sprayer manual for detailed instructions.

2. Use wrench to loosen and remove top filter cap (20).

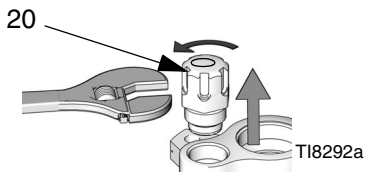

3. Remove o-ring (59*), strainer (23), and filter support (24).

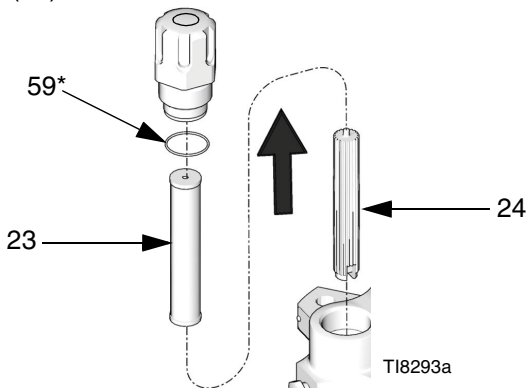

4. Use wrench to loosen and remove bottom filter cap (26). Remove o-rings (22*, 25*).

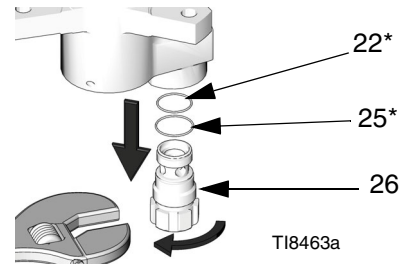

5. Replace o-rings (22*, 25*), strainer (23), and filter support (24).

 O-rings take a set at high pressures. Always replace the o-rings once the filter caps have been removed.

6. Remove pipe plug (49), and use brush or drill to clean port as necessary.

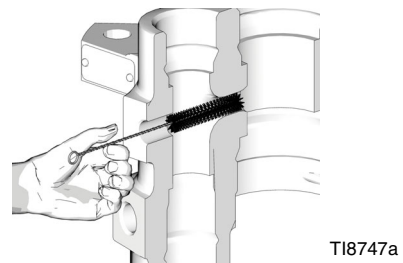

Reassembly

NOTICE

To prevent leaking, ensure that the proper repair components are used for the appropriate series pump. See **Filter Cap Repair Kit, 24F975**, page 30, for more information.

To reassemble the built-in filter:

 Lubricate all o-rings with before installation.

1. Install o-rings (22*, 25*) onto bottom filter cap (26). Then use wrench to reassemble and tighten bottom filter cap. Torque to 40-60 ft-lb (52-82 N•m).

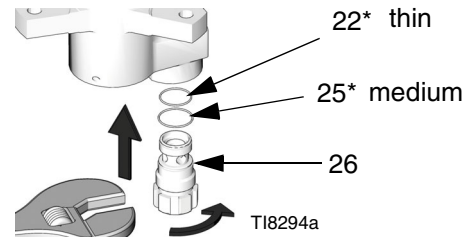

2. Reassemble o-ring (59*) onto top filter cap (20). Install strainer (23), and filter support (24) in top filter cap. Then use wrench to install and tighten top filter cap. Torque to 40-60 ft-lb (52-82 N•m).

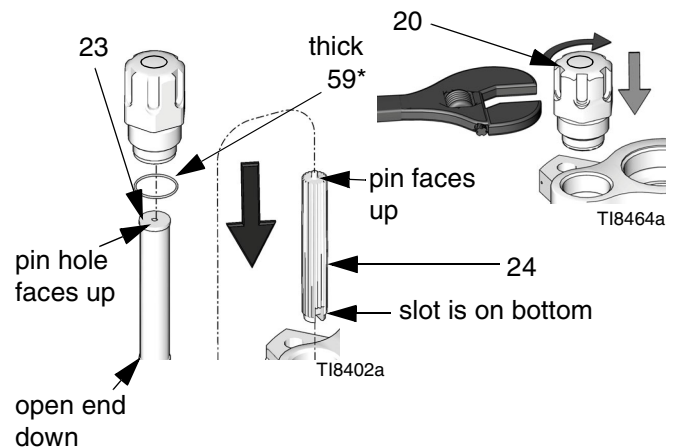

NOTE: 36cc through 115cc Xtreme pump lowers no longer use the short filter screens (23) or supports (24). See page 30 for details.

36cc, 48cc, 54cc, 58cc, and 72cc XP Models

Ref.	Descriptions	36cc	48cc	54cc	58cc	72cc	Qty.
		L036C0	L048C0	L054C0	L058C0	L072C0	
1	ROD, displacement	16D458	16D459	16J900	16D460	16J901	1
2	NUT, packing	16D468	16D468	16D468	16D468	15K029	1
3*	PACKINGS, stack; throat	See Repair Kits on page 26.					1
4*	PACKINGS, stack; piston	See Repair Kits on page 26.					1
7	CARTRIDGE, packing, throat	16D467	16D467	16D467	16D467	16K490	1
8	HOUSING, outlet	15F659	15F659	15F659	15F659	15F659	1
9*	O-RING, top cylinder; PTFE, medium (10 pack)	288067	288067	288067	288067	288067	1
10	PIN, self-locking	244826	244826	244826	244826	244826	1
11	CYLINDER, lower	16D469	16D470	16J906	16D471	16J907	1
12	BALL, piston (pack of 3)	262485	262485	262485	262485	262741	1
13	VALVE, piston	16D464	16D464	16D464	16D464	16K068	1
14	HOUSING, inlet	15F667	15F667	15F667	15F667	15F667	1
15	GUIDE, ball, inlet	16D472	16D472	16D472	16D472	16D472	1
16*	BALL, inlet (pack of 3)	244899	244899	244899	244899	244899	1
17	SHIM, inlet, ball guide (pack of 9)	288064	288064	288064	288064	288064	2
18	SEAT, inlet	15F665	15F665	15F665	15F665	15F665	1
19*	PLUG, throat seal (pack of 10)	247393	247393	247393	247393	247393	1
20 †	CAP, filter, top	16M461	16M461	16M461	16M461	16M461	1
21	SPRING, compression	171941	171941	171941	171941	171941	1
22* †	O-RING, filter; thin, PTFE (10 pack)	244895	244895	244895	244895	244895	1
23	STRAINER, 30 mesh screen; see page 29 for more options	224458	224458	224458	224458	224458	1
24	SUPPORT, filter	186075	186075	186075	186075	186075	1
25* †	O-RING, filter; medium, PTFE (10 pack)	262484	262484	262484	262484	262484	1
26 †	CAP, filter	16M462	16M462	16M462	16M462	16M462	1
27*	O-RING; foot valve, PTFE, thin (pack of 10)	288068	288068	288068	288068	288068	2
29*	O-RING; cylinder bottom, PTFE, medium (pack of 10)	262512	262512	262512	262512	262512	1
30▲	TAG, warning	172479	172479	172479	172479	172479	1
32*	O-RING, PTFE, throat cartridge, medium (10 pack)	262512	262512	262512	262512	262512	1
43	SPRING, foot valve	124007	124007	124007	124007	124007	1
49	PLUG, pipe; 3/8 npt	198292	198292	198292	198292	198292	1
54	PLUG, pipe; 1/2 in.	100737	100737	100737	100737	100737	1
55	HOUSING, rupture disc assy	258962	258962	258962	258962	258962	1
56	ADAPTER, rod	15Y399	15Y399	15Y399	15Y399	15Y399	1
59* †	O-RING, filter; thick, PTFE (10 pack)	262483	262483	262483	262483	262483	1
61	COUPLER, assembly	247167	247167	247167	247167	247167	1

▲ Replacement Danger and Warning labels, tags, and cards are available at no cost.

* Parts included in repair kits (purchase separately).

† See page 30 to verify correct part numbers.

Part numbers listed are for bulk quantities. Individual quantities are included in repair kits. See **Repair Kits** on page 26.

85cc, 90cc, 97cc, and 115cc XP Models

Ref.	Descriptions	85cc	90cc	97cc	115cc	Qty.
		L085C0	L090C0	L097C0	L115C0	
1	ROD, displacement	24B819	16J902	16J903	24B820	1
2	NUT, packing	15K029	15K029	15K029	15K029	1
3*	PACKINGS, stack; throat	See Repair Kits on page 26.				1
4*	PACKINGS, stack; piston	See Repair Kits on page 26.				1
7	CARTRIDGE, packing, throat	15F660	16K490	16K490	15F661	1
8	HOUSING, outlet	15F659	15F659	15F659	15F659	1
9*	O-RING, top cylinder; PTFE, medium (10 pack)	288067	288067	288067	288067	1
10	PIN, self-locking	244826	244826	244826	244826	1
11	CYLINDER, lower	15F682	16J908	16J909	15F656	1
12	BALL, piston (pack of 3)	288065	288065	288065	288065	1
13	VALVE, piston	24B818	24B818	24B818	24B817	1
14	HOUSING, inlet	15F667	15F667	15F667	15F667	1
15	GUIDE, ball, inlet	16D472	16D472	16D472	16D472	1
16*	BALL, inlet (pack of 3)	244899	244899	244899	244899	1
17	SHIM, inlet, ball guide (pack of 9)	288064	288064	288064	288064	2
18	SEAT, inlet	15F665	15F665	15F665	15F665	1
19*	PLUG, throat seal (pack of 10)	247393	247393	247393	247393	1
20†	CAP, filter, top	16M461	16M461	16M461	16M461	1
21	SPRING, compression	171941	171941	171941	171941	1
22*†	O-RING, filter; thin, PTFE (10 pack)	244895	244895	244895	244895	1
23	STRAINER, 30 mesh screen; see page 29 for more options	224458	224458	224458	224458	1
24	SUPPORT, filter	186075	186075	186075	186075	1
25*†	O-RING, filter; medium, PTFE (10 pack)	262484	262484	262484	262484	1
26†	CAP, filter	16M462	16M462	16M462	16M462	1
27*	O-RING; foot valve, PTFE, thin (pack of 10)	288068	288068	288068	288068	2
29*	O-RING; cylinder bottom, PTFE (pack of 10) 256512 medium, 288068 thin	288068	262512	262512	288068	1
30▲	TAG, warning	172479	172479	172479	172479	1
32*	O-RING, PTFE, throat cartridge (10 pack) 256512 medium, 288068 thin	288068	262512	262512	288068	1
43	SPRING, foot valve	124007	124007	124007	124007	1
49	PLUG, pipe; 3/8 npt	198292	198292	198292	198292	1
54	PLUG, pipe; 1/2 in.	100737	100737	100737	100737	1
55	PLUG, pipe, 3/8 npt, hex hd	198292	198292	198292	198292	1
56	ADAPTER, rod					1
59*†	O-RING, filter; thick, PTFE (10 pack)	262483	262483	262483	262483	1
61	COUPLER, assembly	247167	247167	247167	247167	1

▲ Replacement Danger and Warning labels, tags, and cards are available at no cost.

* Parts included in repair kits (purchase separately).

† See page 30 to verify correct part numbers.

Part numbers listed are for bulk quantities. Individual quantities are included in repair kits. See **Repair Kits** on page 26.

145cc, 180cc, 220cc, 250cc, and 290cc XP Models

Ref.	Descriptions	145cc	180cc	220cc	250cc	290cc	Qty.
		L14AC0	L18AC0	L22AC0	L25AC0	L29AC0	
1	ROD, displacement	24B821	24B822	24B823	24B824	24B825	1
2	NUT, packing	15K030	15K031	15K031	15K031	15K031	1
3*	PACKINGS, stack; throat	See Repair Kits on page 26.					1
4*	PACKINGS, stack; piston	See Repair Kits on page 26.					1
7	CARTRIDGE, packing, throat	197325	197326	197327	197328	197327	1
8	HOUSING, outlet	16E151	16E151	16A763	16A763	16A763	1
9*	O-RING, top cylinder; PTFE, medium (10 pack)	244892	244892	244893	244893	244893	1
10	PIN, self-locking	244826	244826	244826	244826	244826	1
11	CYLINDER, lower	197315	197316	197317	197318	197319	1
12	BALL, piston (pack of 3)	253029	253029	244898	244898	244899	1
13	VALVE, piston	24B826	24B827	24B828	24B829	24B830	1
14	HOUSING, inlet	197303	197303	197304	197304	197304	1
15	GUIDE, ball, inlet	198646	198646	198647	198647	198647	1
16*	BALL, inlet (pack of 3)	245128	245128	253030	253030	253030	1
17	SHIM, inlet, ball guide (pack of 9)	244855	244855	244856	244856	244856	3
18	SEAT, inlet	196358	196358	197344	197344	197344	1
19*	PLUG, throat seal (pack of 10)	247394	247394	247395	247395	247395	1
20†	CAP, filter, top	16M461	16M461	16M461	16M461	16M461	1
21	SPRING, compression	171941	171941	171941	171941	171941	1
22*†	O-RING, filter; thin, PTFE (10 pack)	244895	244895	244895	244895	244895	1
23	STRAINER, 30 mesh screen; see page 29 for more options	224458	224458	224458	224458	224458	1
24	SUPPORT, filter	186075	186075	186075	186075	186075	1
25*†	O-RING, filter; medium, PTFE (10 pack)	262484	262484	262484	262484	262484	1
26†	CAP, filter	16M462	16M462	16M462	16M462	16M462	1
27*	O-RING; foot valve, PTFE, thin (pack of 10)	244890	244890	244894	244894	244894	3
29*	O-RING; cylinder bottom, PTFE, thin (pack of 10)	244890	244890	244894	244894	244894	1
30▲	TAG, warning	172479	172479	172479	172479	172479	1
32*	O-RING, PTFE, throat cartridge, thin (10 pack)	244890	244890	244891	244891	244891	1
43	SPRING, foot valve	116801	116801	116802	116802	116802	1
49	PLUG, pipe; 3/8 npt	198292	198292	198292	198292	198292	1
54	PLUG, pipe; 1/2 in.	100737	100737	100737	100737	100737	1
55	PLUG, pipe; 3/8 npt	198292	198292	198292	198292	198292	1
59*†	O-RING, filter; thick, PTFE (10 pack)	262483	262483	262483	262483	262483	1
61	COUPLER, assembly	244819	244819	244819	244819	244819	1

▲ Replacement Danger and Warning labels, tags, and cards are available at no cost.

* Parts included in repair kits (purchase separately).

† See page 30 to verify correct part numbers. Part numbers listed are for bulk quantities. Individual quantities are included in repair kits. See **Repair Kits** on page 26.

Xtreme Sprayer Lower Models

85cc 115cc, 145cc, 180cc, 220cc, 250cc, and 290cc

⚠️ Torque per table on page 13.

⚠️ Torque to 140-150 ft-lb (189-203 N•m).

⚠️ Torque to 40-60 ft-lb (52-82 N•m).

⚠️ Apply lubricant to threads before assembly.

7. Thick, medium, and thin refers to the relative cross-section thickness of the o-ring seals.

⚠️ On model L180C7 only, all 3 shims (17) are installed together between inlet seat (18) and inlet ball guide (15).

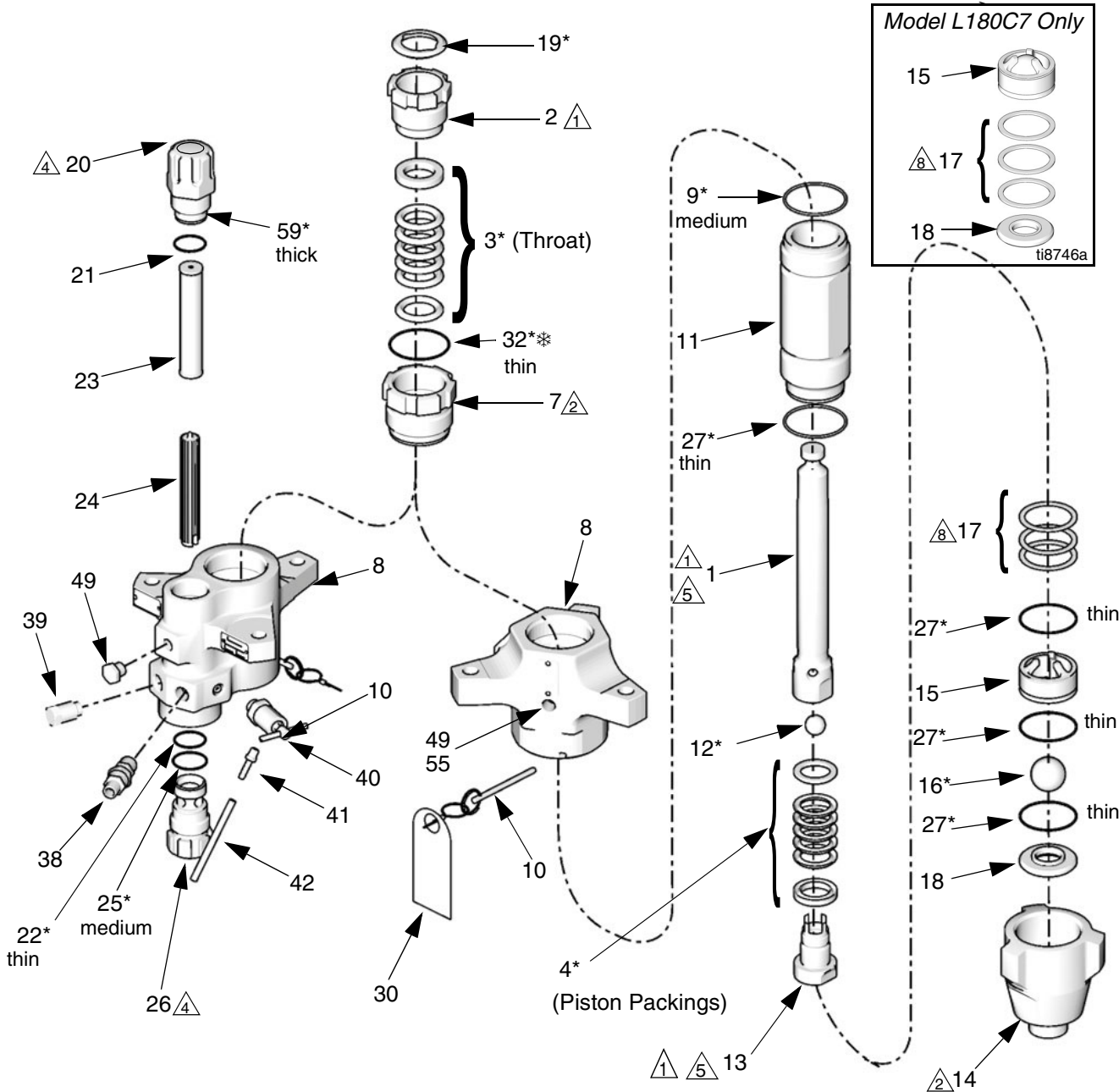

* Blue o-ring for 220, 250, and 290 lowers.

* Parts included in repair kits (purchase separately).
See Repair Kits sections.

T18403a

85cc and 115cc Models

Ref.	Descriptions	85cc		115cc		Qty.
		L085C1 L085C3	L085C2 L085C4	L115C1 L115C3	L115C2 L115C4	
1	ROD, displacement	24B819	24B819	24B820	24B820	1
2	NUT, packing	15K029	15K029	15K029	15K029	1
3*	PACKINGS, stack; throat	See Repair Kits on page 26.				1
4*	PACKINGS, stack; piston	See Repair Kits on page 26.				1
7	CARTRIDGE, packing, throat	15F660	15F660	15F661	15F661	1
8	HOUSING, outlet	15F654	15F659	15F654	15F659	1
9* †	O-RING, top cylinder; PTFE, medium (pack of 10)	288067	288067	288067	288067	1
10	PIN, self-locking	244826	244826	244826	244826	1
11	CYLINDER, lower	15F682	15F682	15F656	15F656	1
12*	BALL, piston; (pack of 3)	288065	288065	288065	288065	1
13	VALVE, piston	24B818	24B818	24B817	24B817	1
14	HOUSING, inlet	15F667	15F667	15F667	15F667	1
15	GUIDE, ball, inlet	15F664	15F664	15F664	15F664	1
16*	BALL, inlet; (pack of 3)	244899	244899	244899	244899	1
17	SHIM, inlet, ball guide (pack of 9)	288064	288064	288064	288064	3
18	SEAT, inlet	15F665	15F665	15F665	15F665	1
19*	PLUG, throat seal (pack of 10)	247393	247393	247393	247393	1
20 †	CAP, filter, top		16M461		16M461	1
21	SPRING, compression		171941		171941	1
22* †	O-RING, filter; thin, PTFE (10 pack)		244895		244895	1
23	STRAINER, 60 mesh screen; see page 29 for more options		224459		224459	1
24	SUPPORT, filter		186075		186075	1
25* †	O-RING, filter; medium, PTFE (10 pack)		262484		262484	1
26 †	CAP, filter, lower		16M462		16M462	1
27*	O-RING; foot valve and cylinder bottom, PTFE, thin (pack of 10)	288068	288068	288068	288068	4
30▲	TAG, warning	172479	172479	172479	172479	1
32*	O-RING, PTFE, throat cartridge, thin (10 pack)	288068	288068	288068	288068	1
38	FITTING, nipple, outlet 1/2 in.		158491		158491	1
39	PLUG, packless; 1/2 in.		24N518		24N518	1
40	VALVE, pressure dump		245143		245143	1
41	FITTING, barbed, plated		116746		116746	1
42	TUBE, nylon		116750		116750	1
49	PLUG, pipe	101754	198292	101754	198292	1
59 †	O-RING, filter; thick, PTFE (10 pack)		262483		262483	1

▲ Replacement Danger and Warning labels, tags, and cards are available at no cost.

* Parts included in repair kits (purchase separately).

† See page 30 to verify correct part numbers.

Part numbers listed are for bulk quantities. Individual quantities are included in repair kits. See **Repair Kits** on page 26.

145cc and 180cc Models

Ref.	Descriptions	145cc				180cc				Qty.
		L145C1 L145C3	L145C2 L145C4	L145C8	L14AC1	L180C1 L180C3 L180C7	L180C9	L180C2 L180C4	L18AC1	
1	ROD, displacement	24B821	24B821	24B821	24B821	24B822	24B822	24B822	24B822	1
2	NUT, packing	15K030	15K030	15K030	15K030	15K030	15K030	15K030	15K030	1
3*	PACKINGS, stack; throat	See Repair Kits on page 26.								1
4*	PACKINGS, stack; piston	See Repair Kits on page 26.								1
7	CARTRIDGE, packing, throat	197325	197325	197325	197325	197326	197326	197326	197326	1
8	HOUSING, outlet	197334	197336	197334	15J673	197334	197334	197336	15J673	1
9*†	O-RING, top cylinder; PTFE, medium (pack of 10)	244892	244892	244892	244892	244892	244892	244892	244892	1
10	PIN, self-locking	244826	244826	244826	244826	244826	244826	244826	244826	1
11	CYLINDER, lower	197315	197315	197315	197315	197316	197316	197316	197316	1
12*	BALL, piston; (pack of 3)	253029	253029	253029	253029	253029	253029	253029	253029	1
13	VALVE, piston	24B826	24B826	24B826	24B826	24B827	24B827	24B827	24B827	1
14	HOUSING, inlet	197303	197303	197303	197303	197303	197303	197303	197303	1
15	GUIDE, ball, inlet	197307	197307	197307	197307	197307	197307	197307	197307	1
16*	BALL, inlet; (pack of 3)	245128	245128	245128	245128	245128	245128	245128	245128	1
17	SHIM, inlet, ball guide (pack of 9)	244855	244855	244855	244855	244855	244855	244855	244855	3
18	SEAT, inlet	196358	196358	196358	196358	196358	196358	196358	196358	1
19*	PLUG, throat seal (pack of 10)	247394	247394	247394	247394	247394	247394	247394	247394	1
20†	CAP, filter, top		16M461					16M461		1
21	SPRING, compression		171941					171941		1
22*	O-RING, filter; thin, PTFE (10 pack)		244895					244895		1
23	STRAINER, 60 mesh screen; (2 pack) see page 29 for more options		224459					224459		1
24	SUPPORT, filter		186075					186075		1
25*†	O-RING, filter; medium, PTFE (10 pack)		262484					262484		1
26†	CAP, filter		16M462					16M462		1
27*	O-RING; foot valve and cylinder bottom, PTFE, thin (pack of 10)	244890	244890	244890	244890	244890	244890	244890	244890	4
30▲	TAG, warning	172479	172479	172479	172479	172479	172479	172479	172479	1
32*	O-RING, PTFE, throat cartridge, thin (10 pack)	244890	244890	244890	244890	244890	244890	244890	244890	1
38	FITTING, nipple, outlet 1/2 in.		158491					158491		1
39	PLUG, packless; 1/2 in.		24N518					24N518		1
40	VALVE, pressure dump		245143					245143		1
41	FITTING, barbed, plated		116746					116746		1
42	TUBE, nylon		116750					116750		1
49	PLUG, pipe	101754	198292		101754	101754		198292	101754	1
55	HOUSING, rupture disc			127628			258962			1
59†	O-RING, filter; thick, PTFE (10 pack)		262483					262483		1

▲ Replacement Danger and Warning labels, tags, and cards are available at no cost.

* Parts included in repair kits (purchase separately).

† See page 30 to verify correct part numbers.

Part numbers listed are for bulk quantities. Individual quantities are included in repair kits. See **Repair Kits** on page 26.

220cc and 250cc Models

Ref.	Descriptions	220cc				250cc			Qty.
		L220C1 L220C3	L220C9	L220C2 L220C4	L22AC1	L250C1 L250C3	L250C2 L250C4	L250C8	
1	ROD, displacement	24B823	24B823	24B823	24B823	24B824	24B824	24B824	1
2	NUT, packing	15K031	15K031	15K031	15K031	15K031	15K031	15K031	1
3*	PACKINGS, stack; throat	See Repair Kits on page 26.							1
4*	PACKINGS, stack; packing	See Repair Kits on page 26.							1
7	CARTRIDGE, packing, throat	197327	197327	197327	197327	197328	197328	197328	1
8	HOUSING, outlet	197335	197335	197337	15H722	197335	197337	197335	1
9†	O-RING, top cylinder; PTFE, medium (pack of 10)	244893	244893	244893	244893	244893	244893	244893	1
10	PIN, self-locking	244826	244826	244826	244826	244826	244826	244826	1
11	CYLINDER, lower	197317	197317	197317	197317	197318	197318	197318	1
12	BALL, piston; (pack of 3)	244898	244898	244898	244898	244898	244898	244898	1
13	VALVE, piston	24B828	24B828	24B828	24B828	24B829	24B829	24B829	1
14	HOUSING, inlet	197304	197304	197304	197304	197304	197304	197304	1
15	GUIDE, ball, inlet	198647	198647	198647	198647	198647	198647	198647	1
16*	BALL, inlet; (pack of 3)	253030	253030	253030	253030	253030	253030	253030	1
17	SHIM, inlet, ball guide (pack of 9)	244856	244856	244856	244856	244856	244856	244856	3
18	SEAT, inlet	197344	197344	197344	197344	197344	197344	197344	1
19*	PLUG, throat seal (pack of 10)	247395	247395	247395	247395	247395	247395	247395	1
20†	CAP, filter, top			16M461			16M461		1
21	SPRING, compression			171941			171941		1
22*†	O-RING, filter; thin, PTFE (10 pack)			244895			244895		1
23	STRAINER, 60 mesh screen (2 pack); see page 29 for more options			224459			224459		1
24	SUPPORT, filter			186075			186075		1
25*†	O-RING, filter; medium, PTFE (10 pack)			262484			262484		1
26†	CAP, filter			16M462			16M462		1
27*†	O-RING; foot valve and cylinder bottom, PTFE, thin (pack of 10)	244894	244894	244894	244894	244894	244894	244894	4
30▲	TAG, warning	172479	172479	172479	172479	172479	172479	172479	1
32*†	O-RING, PTFE, throat cartridge, blue, thin (10 pack)	244891	244891	244891	244891	244891	244891	244891	1
38	FITTING, nipple, outlet 1/2 in.			158491			158491		1
39	PLUG, packless; 1/2 in.			24N518			24N518		1
40	VALVE, pressure dump			245143			245143		1
41	FITTING, barbed, plated			116746			116746		1
42	TUBE, nylon			116750			116750		1
49	PLUG, pipe	101754		198292	101754	101754	198292		1
55	HOUSING, rupture disc		258962					258962	1
59*†	O-RING, filter; thick, PTFE (10 pack)			262483			262483		1

▲ Replacement Danger and Warning labels, tags, and cards are available at no cost.

* Parts included in repair kits (purchase separately).

† See page 30 to verify correct part numbers.

Part numbers listed are for bulk quantities. Individual quantities are included in repair kits. See **Repair Kits** on page 26.

290cc Models

Ref.	Descriptions	290cc				Qty.
		24N942	L290C1 L290C3	L290C2 L290C4	L29AC1	
1	ROD, displacement	16R994	24B825	24B825	24B825	1
2	NUT, packing	15K031	15K031	15K031	15K031	1
3*	PACKINGS, stack, throat	See Repair Kits , page 26.				1
4*	PACKINGS, stack; piston	See Repair Kits , page 26.				1
7	CARTRIDGE, packing, throat	197327	197327	197327	197327	1
8	HOUSING, outlet	197335	197335	197337	15H722	1
9* †	O-RING, top cylinder; PTFE, medium (pack of 10)	244893	244893	244893	244893	1
10	PIN, self-locking	244826	244826	244826	244826	1
11	CYLINDER, lower	197319	197319	197319	197319	1
12	BALL, piston; (pack of 3)	244899	244899	244899	244899	1
13	VALVE, piston	24B830	24B830	24B830	24B830	1
14	HOUSING, inlet	197304	197304	197304	197304	1
15	GUIDE, ball, inlet	198647	198647	198647	198647	1
16*	BALL, inlet; (pack of 3)	253030	253030	253030	253030	1
17	SHIM, inlet, ball guide (pack of 9)	244856	244856	244856	244856	3
18	SEAT, inlet	197344	197344	197344	197344	1
19*	PLUG, throat seal (pack of 10)	247395	247395	247395	247395	1
20 †	CAP, filter, top			16M461		1
21	SPRING, compression			171941		1
22* †	O-RING, filter; thin, PTFE (10 pack)			244895		1
23	STRAINER, 60 mesh screen; (2 pack) see page 29 for more options			224459		1
24	SUPPORT, filter			186075		1
25* †	O-RING, filter; medium, PTFE (10 pack)			262484		1
26 †	CAP, filter			16M462		1
27*	O-RING; foot valve and cylinder bottom, PTFE, thin (pack of 10)	244894	244894	244894	244894	4
30▲	TAG, warning	172479	172479	172479	172479	1
32*	O-RING, PTFE, throat cartridge, blue, thin (10 pack)	244891	244891	244891	244891	1
38	FITTING, nipple, outlet 1/2 in.			158491		1
39	PLUG, packless; 1/2 in.			24N518		1
40	VALVE, pressure dump			245143		1
41	FITTING, barbed, plated			116746		1
42	TUBE, nylon			116750		1
49	PLUG, pipe	101754	101754	198292	101754	1
59* †	O-RING, filter; thick, PTFE (10 pack)			262483		1

▲ Replacement Danger and Warning labels, tags, and cards are available at no cost.

* Parts included in repair kits (purchase separately).

† See page 30 to verify correct part numbers.

Part numbers listed are for bulk quantities. Individual quantities are included in repair kits. See **Repair Kits** on page 26.

Repair Kits

Xtreme Seals™ Repair Kits

Repair kits contain a set of three UHMWPE and two leather packings that are ideal for abrasive applications. Xtreme Seal packing sets are standard in Xtreme NXT Spray Packages and are used with models L___ C1, L___ C2, L___ C8, and some 5.9 in.bolt pattern models. Kits also include items 9, 12, 16, 19, 22, 25, 27, 32, and 59. See parts list for your lower model.

Throat Packing (3) Detail

Ref.	Description	Qty.
3a	GLAND, packing, male (4 pack)	1
3b	GLAND, packing, female (4 pack)1	1
3c	V-PACKING, leather (10 pack)	2
3d	V-PACKING, UHMWPE (10 pack)	3

Piston Packing (4) Detail

Ref.	Description	Qty.
4a	GLAND, packing, male (4 pack)	1
4b	GLAND, packing, female (4 pack)1	1
4c	V-PACKING, leather (10 pack)	2
4d	V-PACKING, UHMWPE (10 pack)	3

Lower Size	Kit	Descriptions, Reference Numbers, and Quantity							
		Throat Packing (3)				Piston Packing (4)			
		3a (male)	3b (female)	3c (leather)	3d (UHMWPE)	4a male	4b (female)	4c (leather)	4d (UHMWPE)
85cc	24F973	288070	288069	288078	288077	288072	288071	288081	288080
115cc	24F972	288074	288073	288076	288075	288074	288073	288076	288075
145cc	24F971	244881	244875	244869	244863	244881	244875	244869	244863
180cc	24F969	244882	244876	244870	244864	244882	244876	244870	244864
220cc	24F967	244883	244877	244871	244865	244884	244878	244872	244866
250cc	24F965	245232	245233	245230	245231	245232	245233	245230	245231
290cc	24F963	244885	244879	244873	244867	244886	244880	244874	244868
Qty:		1	1	2	3	1	1	2	3

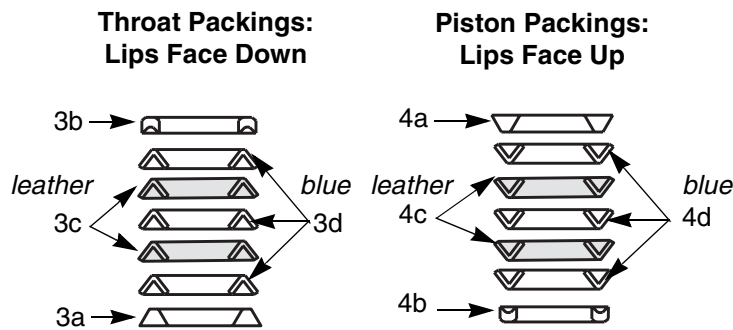

Lubricate packings; soak leather packings in oil for one hour before assembly.

FIG. 5: Xtreme Seals™ Repair Kits

Tuff-Stack™ Repair Kits

Repair kits contain a set of five carbon-filled PTFE packings that are ideal for chemical resistance and higher temperatures. Not ideal for abrasive applications. These kits are for models L___ C3, L___ C4, and some 5.9 in.bolt pattern models. Kits also include items 9, 12, 16, 19, 22, 25, 27, 32, and 59. See parts list for your lower model.

Throat Packing (3) Detail

Ref.	Description	Qty.
3a	GLAND, packing, male (4 pack)	1
3b	GLAND, packing, female (4 pack)	1
3e	V-PACKING, carbon-filled PTFE (10 pack)	5

Piston Packing (4) Detail

Ref.	Description	Qty.
4a	GLAND, packing, male (4 pack)	1
4b	GLAND, packing, female (4 pack)	1
4e	V-PACKING, carbon-filled PTFE (10 pack)	5

Lower Size	Kit	Descriptions, Reference Numbers, and Quantity					
		Throat Packings (3)			Piston Packings (4)		
		3a (male)	3b (female)	3e (Carbon-filled PTFE)	4a (male)	4b (female)	4e (Carbon-filled PTFE)
36cc	262504	262487	262486	262490	262489	262488	262491
48cc	262505	262493	262492	262496	262495	262494	262497
58cc	262506	262499	262498	262502	262501	262500	262503
85cc	262507	288070	288069	288079	288072	288071	288082
115cc	262508	288074	288073	288066	288074	288073	288066
145cc	262510	244881	244875	244857	244881	244875	244857
180cc	24F970	244882	244876	244858	244882	244876	244858
220cc	24F968	244883	244877	244859	244884	244878	244860
250cc	24F966	245232	246530	245229	245232	246530	245229
290cc	24F964	244885	244879	244861	244886	244880	244862
Qty:		1	1	5	1	1	5

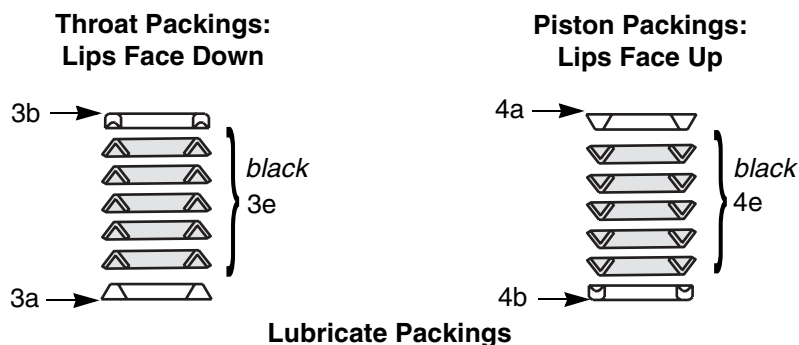

FIG. 6: Tuff-Stack™ Seals Repair Kits

X-Tuff[®] Repair Kits

Repair kits contain a set of three UHMWPE and two carbon-filled PTFE packings that are for chemical resistance and durability in applications below 140°F (60°C). X-Tuff packing sets are standard in XP Proportioners and are used with L___ C0, L___ C7, and L___ C9 models and some 5.9 in. bolt pattern models. Kits also include items 9, 12, 16, 19, 22, 25, 27, 29, 32, 43, and 59. See parts list for your lower model.

NOTE: All L___ C0 XP lowers built prior to April 2012 came with Tuff-Stack packing sets.

Throat Packing (3) Detail

Piston Packing (4) Detail

Ref.	Description	Qty.	Ref.	Description	Qty.
3a	GLAND, packing, male (4 pack)	1	4a	GLAND, packing, male (4 pack)	1
3b	GLAND, packing, female (4 pack)	1	4b	GLAND, packing, female (4 pack)	1
3c	V-PACKING, carbon-filled PTFE (10 pack)	2	4c	V-PACKING, carbon-filled PTFE (10 pack)	2
3d	V-PACKING, UHMWPE (10 pack)	3	4d	V-PACKING, UHMWPE (10 pack)	3

Lower Size	Kit	Descriptions, Reference Numbers, and Quantity							
		Throat Packing (3)				Piston Packing (4)			
		3a (male)	3b (female)	3c (Carbon-filled PTFE)	3d (UHMWPE)	4a (male)	4b (female)	4c (Carbon-filled PTFE)	4d (UHMWPE)
36cc	262786	262487	262486	262490	262796	262489	262488	262491	262797
48cc	262787	262493	262492	262496	262798	262495	262494	262497	262799
54cc	262774	262743	262742	262747	262746	262745	262744	262749	262748
58cc	262788	262499	262498	262502	262801	262501	262500	262503	262802
72cc	262775	262751	262750	262755	262754	262753	262752	262757	262756
85cc	262789	288070	288069	288079	288077	288072	288071	288082	288080
90cc	262776	262759	262758	262763	262762	262761	262760	262765	262764
97cc	262777	262767	262766	262771	262770	262769	262768	262773	262772
115cc	262790	288074	288073	288066	288075	288074	288073	288066	288075
145cc	262791	244881	244875	244857	244863	244881	244875	244857	244863
180cc	262792	244882	244876	244858	244864	244882	244876	244858	244864
220cc	262793	244883	244877	244859	244865	244884	244878	244860	244866
250cc	262794	245232	245233	245229	245231	245232	245233	245229	245231
290cc	262795	244885	244879	244861	244867	245866	244880	244862	244868
Qty:		1	1	2	3	1	1	3	3

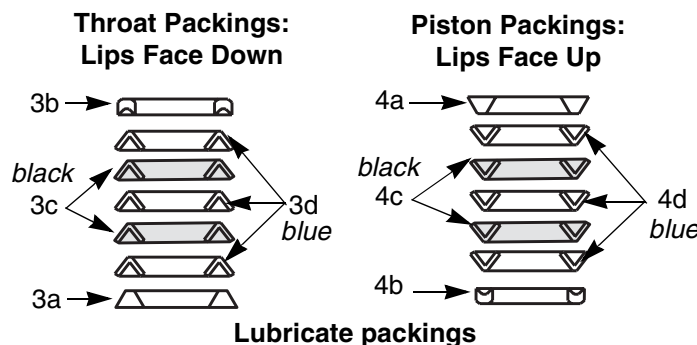



FIG. 7: X-Tuff[®] Repair Kits

Kits

Inlet Ball Spring Kits

Use to improve change over rates in longer ball travel configurations. Order kit that corresponds with your lower model. See manual 406527.

 All XP Xtreme pumps include inlet springs.

Kit	Lower Models
245190	145cc, 180cc sizes
245191	220cc, 250cc, 290cc sizes

Fluid Drain Valve Repair Kit 245145

 Not for use with XP lowers.

Ref.	Description	Qty.
1	BALL, carbide	1
2	RING, retaining	1
3	O-RING, PTFE	2
4	SEAT, valve	1
5	GASKET	1

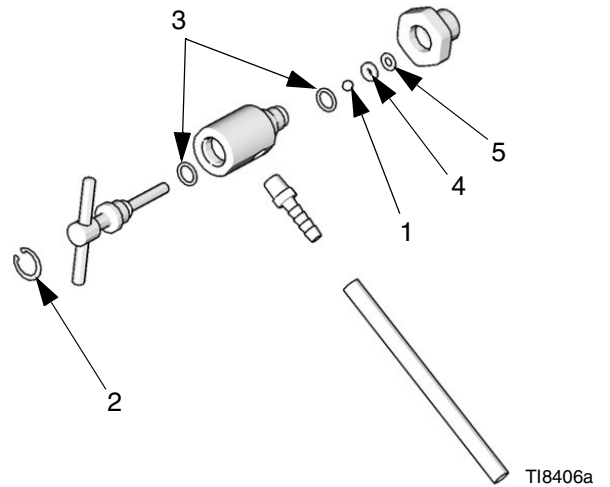

Replacement Strainers (Ref. 23)

For models with built-in filters, Series A and B pumps used 3 in. (76.2 mm) strainers 236495 in pump sizes 36-115cc. All Xtreme pumps now use 5.65 in. (143.5 mm) strainers listed below. See page 30 for conversion kit.

 Standard Xtreme filter pumps come with 60 mesh
 XP Xtreme filter pumps comes with 30 mesh.

Lower Size	2 Pack		
	30 mesh	60 mesh	100 mesh
All	224458	224459	224468

Lower Size	25 Pack		
	30 mesh	60 mesh	100 mesh
All	238436	238438	238440

Filter Cap Repair Kit, 24F975

Use to improve sealing of Series A filters. See manual 406882 for more information.

Ref.	Description	Qty.
20	CAP, filter, top; all pumps	1
21	SPRING	1
22	O-RING; white, thin	1
23a	STRAINER, 30 mesh, 5.65 in. (143.5 mm)	1
23b	STRAINER, 60 mesh, 5.65 in. (143.5 mm)	1
24	SUPPORT, filter	1
25	O-RING; white, medium	1
26	CAP, filter	1
59	O-RING, PTFE; white, thick	1

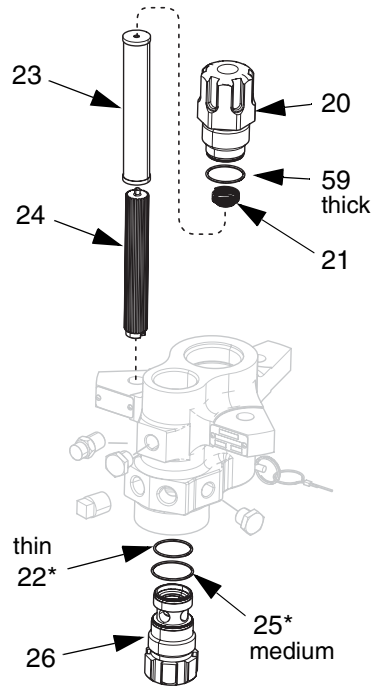

Series Change

The original filter cap seals were changed in 2010 for improved sealing. The o-rings are not interchangeable between different series filter caps.

The pump series for all Xtreme and XP lowers are identified by the circular grooves on the top filter cap (20).

Benefits of the new filter cap repair kit include:

- Compatible with all pump sizes
- Improves sealing
- Ensures filters are installed correctly

Series A

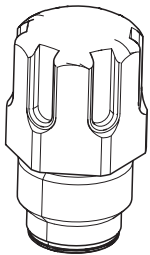

Series B

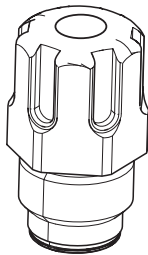

Series C

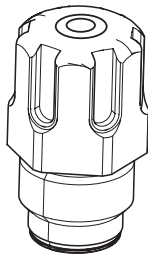

Series	Change Description
B	Uses thick, medium, and thin cross-section o-rings.
	Filter caps changed to accept new o-rings
C	Uses 5.65 in. (143.5 mm) strainers and supports all sizes.

Dimensions

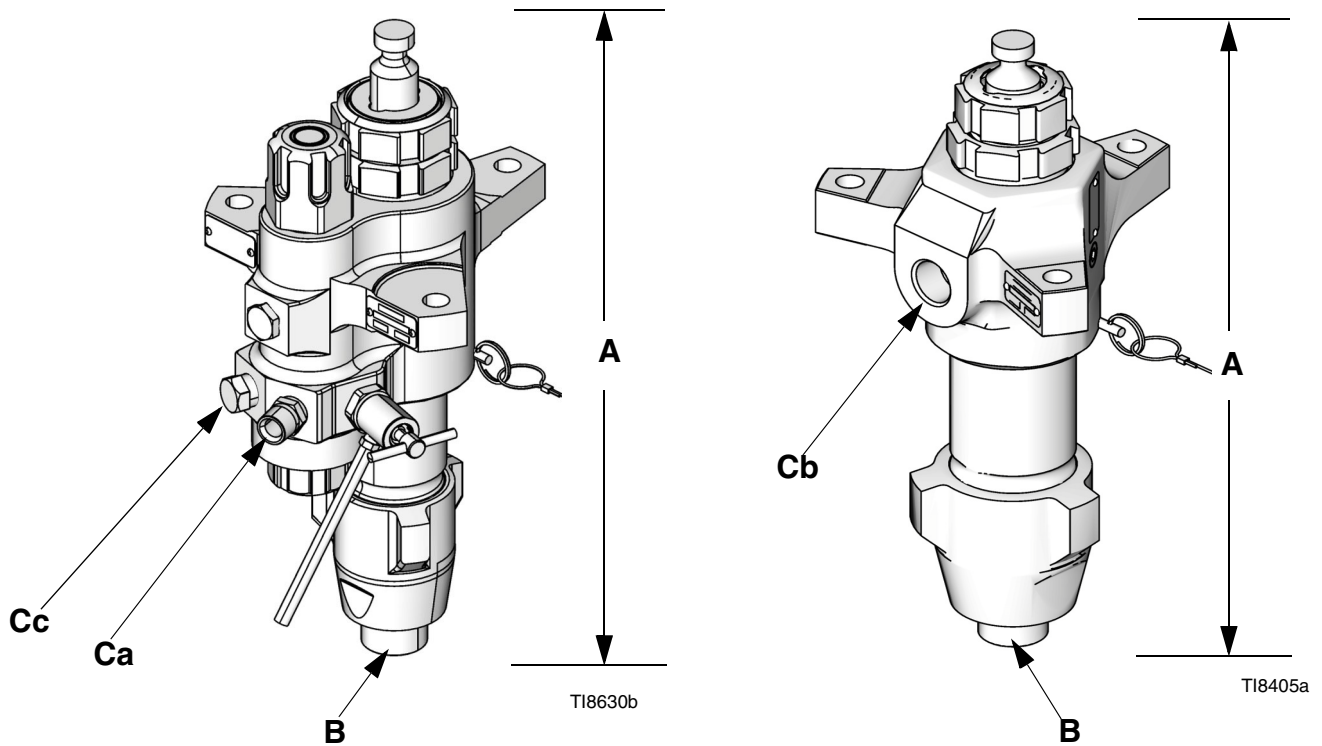

Lowers with Built-in Filters

Lowers without Built-in Filters

Lower Dimensions

Lower	A (Height) in. (mm)	B (Inlet) in. npt(m)	Ca (Outlet) in. npt(m)	Cb (Outlet) in. npt(f)	Cc (Outlet) in. npt(f)	Weight lbs (kg)	
						Without Filter	With Filter
36cc	17.0 (432)	1-1/4	1/2	NA	1/2	NA	36 (16.3)
48cc	17.0 (432)	1-1/4	1/2	NA	1/2	NA	36 (16.3)
54cc	17.0 (432)	1-1/4	1/2	NA	1/2	NA	36 (16.3)
58cc	17.0 (432)	1-1/4	1/2	NA	1/2	NA	36 (16.3)
72cc	17.0 (432)	1-1/4	1/2	NA	1/2	NA	36 (16.3)
85cc	17.0 (432)	1-1/4	1/2	1/2	1/2	28 (12.7)	36 (16.3)
90cc	17.0 (432)	1-1/4	1/2	NA	1/2	NA	36 (16.3)
97cc	17.0 (432)	1-1/4	1/2	NA	1/2	NA	36 (16.3)
115cc	17.0 (432)	1-1/4	1/2	1/2	1/2	28 (12.7)	36 (16.3)
145cc	17.0 (432)	1-1/4	1/2	3/4	1/2	38 (17.3)	48 (21.8)
14Acc	17.0 (432)	1-1/4	1/2	3/4	1/2	38 (17.3)	48 (21.8)
180cc	17.0 (432)	1-1/4	1/2	3/4	1/2	38 (17.3)	48 (21.8)
18Acc	17.0 (432)	1-1/4	1/2	3/4	1/2	38 (17.3)	48 (21.8)
220cc	17.0 (432)	1-1/4	1/2	1	1/2	42 (19.1)	52 (23.6)
22Acc	17.0 (432)	1-1/4	1/2	1	1/2	42 (19.1)	52 (23.6)
250cc	17.0 (432)	1-1/4	1/2	1	1/2	42 (19.1)	52 (23.6)
290cc	17.0 (432)	1-1/4	1/2	1	1/2	43 (19.5)	53 (24.1)
29Acc	17.0 (432)	1-1/4	1/2	1	1/2	43 (19.5)	53 (24.1)

Outlet Housing Mounting Hole Layout

5.9 in. (150 mm) Outlet Housing (example) Shown

Applies to 36, 48, 54, 58, 72, 85, 90, 97, 115, 14A, 18A, 22A, and 29Acc Lowers

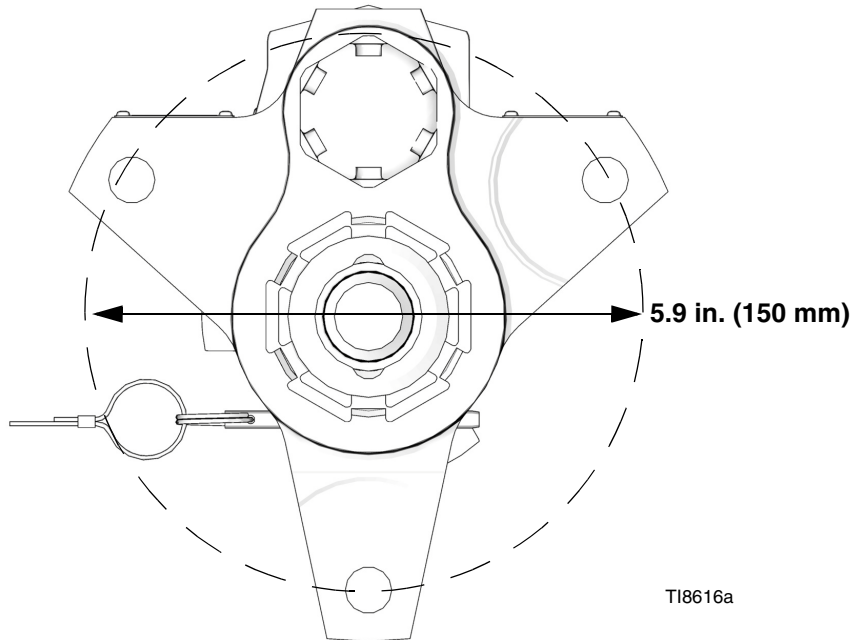

8.0 in. (203 mm) Outlet Housing (example) Shown

Applies to 145, 180, 220, 250, and 290cc Lowers

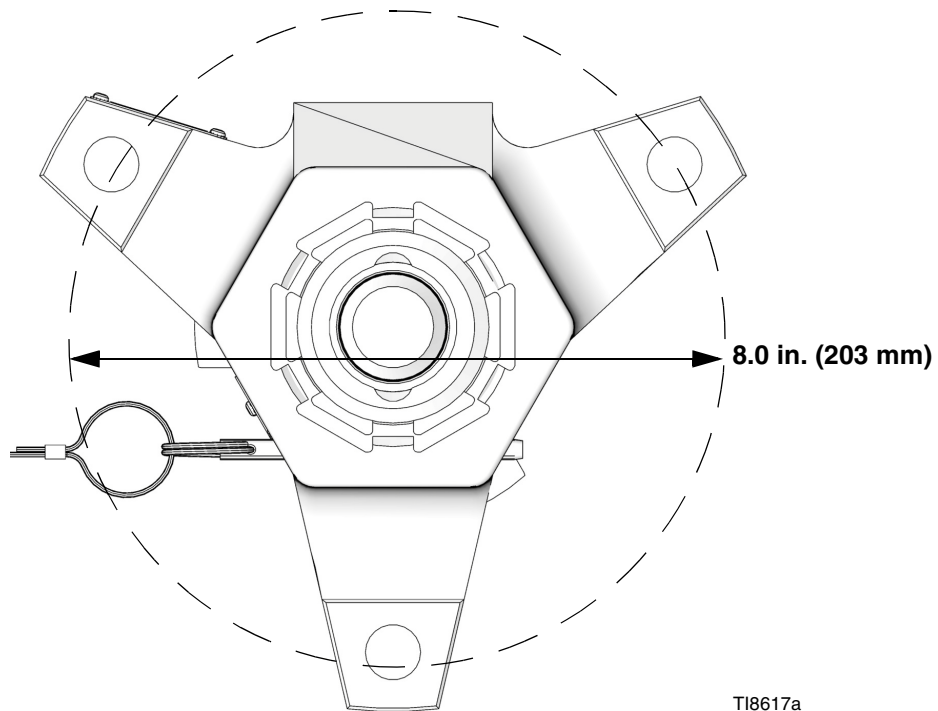

Technical Data

Xtreme Lowers		
	US	Metric
Maximum operating temperature	180° F	82° C
Wetted Parts	Carbon Steel; Alloy Steel; 304, 440 and 17-4 PH Grades of Stainless Steel; Zinc and Nickel Plating; Ductile Iron; Tungsten Carbide; PTFE; Leather	
Stroke length	4.75 in.	12.06 cm
Maximum fluid working pressure		
L036C0	7250 psi	50 MPa, 500 bar
L046C0	7250 psi	50 MPa, 500 bar
L054C0	7250 psi	50 MPa, 500 bar
L058C0	7250 psi	50 MPa, 500 bar
L072C0	7250 psi	50 MPa, 500 bar
L085C0, L085C1, L085C2, L085C3, L085C4	7250 psi	50 MPa, 500 bar
L090C0	7250 psi	50 MPa, 500 bar
L097C0	7250 psi	50 MPa, 500 bar
L115C0, L115C1, L115C2, L115C3, L115C4	7250 psi	50 MPa, 500 bar
L145C0, L145C1, L145C2, L145C3, L145C4, L14AC1	7400 psi	51 MPa, 511 bar
L145C8	4500 psi	31 MPa, 310 bar
L180C0, L180C1, L180C2, L180C3, L180C4, L180C7, L180C9, L18AC1	7400 psi	51 MPa, 511 bar
L220C0, L220C1, L220C2, L220C3, L220C4, L220C9, L22AC1	6000 psi	41 MPa, 414 bar
L250C0, L250C1, L250C2, L250C3, L250C4	5600 psi	39 MPa, 386 bar
L250C8	2600 psi	18 MPa, 179 bar
L290C0, L290C1, L290C2, L290C3, L290C4, L29AC1, 24N942	5600 psi	39 MPa, 386 bar
Nominal displacement per cycle		
L036C0	36cc	
L046C0	46cc	
L054C0	54cc	
L058C0	58cc	
L072C0	72cc	
L085C0, L085C1, L085C2, L085C3, L085C4	85cc	
L090C0	90cc	
L097C0	97cc	
L115C0, L115C1, L115C2, L115C3, L115C4	115cc	
L145C0, L145C1, L145C2, L145C3, L145C4, L145C8, L14AC1	145cc	
L180C0, L180C1, L180C2, L180C3, L180C4, L180C7, L180C9, L18AC1	185cc	
L220C0, L220C1, L220C2, L220C3, L220C4, L220C9, L22AC1	220cc	
L250C0, L250C1, L250C2, L250C3, L250C4	250cc	
L290C0, L290C1, L290C2, L290C3, L290C4, L29AC1, 24N942	290cc	

Technical Data

Xtreme Lowers		
	US	Metric
Effective Area		
L036C0	0.2325 in.	1.500 cm
L046C0	0.3100 in.	2.000 cm
L054C0	0.349 in.	2.250 cm
L058C0	0.3715 in.	2.397 cm
L072C0	0.465 in.	3.000 cm
L085C0, L085C1, L085C2, L085C3, L085C4	0.5542 in.	3.575 cm
L090C0	0.581 in.	3.750 cm
L097C0	0.620 in.	4.000 cm
L115C0, L115C1, L115C2, L115C3, L115C4	0.7430 in.	4.793 cm
L145C0, L145C1, L145C2, L145C3, L145C4, L145C8, L14AC1	0.9300 in.	6.000 cm
L180C0, L180C1, L180C2, L180C3, L180C4, L180C7, L180C9, L18AC1	1.1624 in.	7.500 cm
L220C0, L220C1, L220C2, L220C3, L220C4, L220C9, L22AC1	1.395 in.	9.000 cm
L250C0, L250C1, L250C2, L250C3, L250C4, L250C8	1.620 in.	10.452 cm
L290C0, L290C1, L290C2, L290C3, L290C4, L29AC1, 24N942	1.860 in.	12.000 cm

Graco Standard Warranty

Graco warrants all equipment referenced in this document which is manufactured by Graco and bearing its name to be free from defects in material and workmanship on the date of sale to the original purchaser for use. With the exception of any special, extended, or limited warranty published by Graco, Graco will, for a period of twelve months from the date of sale, repair or replace any part of the equipment determined by Graco to be defective. This warranty applies only when the equipment is installed, operated and maintained in accordance with Graco's written recommendations.

This warranty does not cover, and Graco shall not be liable for general wear and tear, or any malfunction, damage or wear caused by faulty installation, misapplication, abrasion, corrosion, inadequate or improper maintenance, negligence, accident, tampering, or substitution of non-Graco component parts. Nor shall Graco be liable for malfunction, damage or wear caused by the incompatibility of Graco equipment with structures, accessories, equipment or materials not supplied by Graco, or the improper design, manufacture, installation, operation or maintenance of structures, accessories, equipment or materials not supplied by Graco.

This warranty is conditioned upon the prepaid return of the equipment claimed to be defective to an authorized Graco distributor for verification of the claimed defect. If the claimed defect is verified, Graco will repair or replace free of charge any defective parts. The equipment will be returned to the original purchaser transportation prepaid. If inspection of the equipment does not disclose any defect in material or workmanship, repairs will be made at a reasonable charge, which charges may include the costs of parts, labor, and transportation.

THIS WARRANTY IS EXCLUSIVE, AND IS IN LIEU OF ANY OTHER WARRANTIES, EXPRESS OR IMPLIED, INCLUDING BUT NOT LIMITED TO WARRANTY OF MERCHANTABILITY OR WARRANTY OF FITNESS FOR A PARTICULAR PURPOSE.

Graco's sole obligation and buyer's sole remedy for any breach of warranty shall be as set forth above. The buyer agrees that no other remedy (including, but not limited to, incidental or consequential damages for lost profits, lost sales, injury to person or property, or any other incidental or consequential loss) shall be available. Any action for breach of warranty must be brought within two (2) years of the date of sale.

GRACO MAKES NO WARRANTY, AND DISCLAIMS ALL IMPLIED WARRANTIES OF MERCHANTABILITY AND FITNESS FOR A PARTICULAR PURPOSE, IN CONNECTION WITH ACCESSORIES, EQUIPMENT, MATERIALS OR COMPONENTS SOLD BUT NOT MANUFACTURED BY GRACO. These items sold, but not manufactured by Graco (such as electric motors, switches, hose, etc.), are subject to the warranty, if any, of their manufacturer. Graco will provide purchaser with reasonable assistance in making any claim for breach of these warranties.

In no event will Graco be liable for indirect, incidental, special or consequential damages resulting from Graco supplying equipment hereunder, or the furnishing, performance, or use of any products or other goods sold hereto, whether due to a breach of contract, breach of warranty, the negligence of Graco, or otherwise.

FOR GRACO CANADA CUSTOMERS

The Parties acknowledge that they have required that the present document, as well as all documents, notices and legal proceedings entered into, given or instituted pursuant hereto or relating directly or indirectly hereto, be drawn up in English. Les parties reconnaissent avoir convenu que la rédaction du présente document sera en Anglais, ainsi que tous documents, avis et procédures judiciaires exécutés, donnés ou intentés, à la suite de ou en rapport, directement ou indirectement, avec les procédures concernées.

Graco Information

For the latest information about Graco products, visit www.graco.com.

TO PLACE AN ORDER, contact your Graco distributor or call to identify the nearest distributor.

Phone: 612-623-6921 **or Toll Free:** 1-800-328-0211 **Fax:** 612-378-3505

All written and visual data contained in this document reflects the latest product information available at the time of publication. Graco reserves the right to make changes at any time without notice.

For patent information, see www.graco.com/patents.

Original instructions. This manual contains English. MM 311762

Graco Headquarters: Minneapolis
International Offices: Belgium, China, Japan, Korea

GRACO INC. AND SUBSIDIARIES • P.O. BOX 1441 • MINNEAPOLIS MN 55440-1441 • USA
Copyright 2006, Graco Inc. All Graco manufacturing locations are registered to ISO 9001.

www.graco.com

Revision W - August 2014