



GRACO® XTREME® NXT® PASSIVE FIRE PROTECTION SINGLE COMPONENT SPRAYER



PART NUMBERS AND SCHEMATICS GUIDE

Company Profile

Since 1944, Marco has developed a strong tradition of providing innovative and reliable products and services to the surface preparation and protective coatings industries. We are the world's premier provider of Abrasives, Blasting Equipment, Coating Equipment, Engineered Systems, Rental Equipment, Safety Equipment, Service, and Repair.

Through innovative designs and a total commitment to quality, Marco manufactures products that increase production rates, create a safer workplace, and reduce maintenance costs. Marco's industry experience, manufacturing capabilities, legendary customer service, product availability, logistics services, and technology leadership is your assurance that we deliver high quality products and services, providing the best value to you, our customer.

The Marco Difference

- **Industry Experience** – With Marco on your team, you have access to expertise which can only come from over 65 years of industry leadership. We have organized our engineering department, production specialists, customer operations, and safety support into a "Center of Competence." As a Marco customer, you have access to hundreds of years of cumulative experience related to your operations.
- **Manufacturing Excellence** – Marco is a U.S. based, ISO 9001:2008 certified manufacturer of equipment for the Surface Preparation and Protective Coatings industries. Marco's engineers benchmark the industry to ensure that we design and manufacture superior products that set the "Gold Standard" for performance, safety, and quality.
- **Legendary Customer Service** – Marco's legendary customer service team is staffed by friendly, highly-trained individuals who are focused on providing the highest level of product support, order accuracy, and customer satisfaction.
- **Product Availability** – We stock over 10,000 SKU's and have over 45 shipping locations to serve North American and International markets for all major brands of blasting and painting equipment. As the largest provider of surface preparation and protective coatings equipment in the world, our inventory levels and product availability are unmatched.
- **Logistics Services** – Marco's in-house logistics team is dedicated to moving your shipment anywhere in the world. We move over 14,000 truckloads every year, allowing you to save on freight costs by leveraging our buying power. Lower your process costs with a single invoice, which includes product and freight.
- **Technology Leadership** – Our website provides: Operator's Manuals, Part Numbers and Schematics Guides, MSDS information, and Features, Advantages, and Benefits Guides, providing access to information 24/7. Our Extranet application allows you to receive quotes and place orders online. Our Intranet maintains a complete record of your purchase history to assist with ongoing support of your existing equipment and future purchasing decisions.

Vision Statement

Marco is the world's premier provider of Abrasives, Blasting Equipment, Coating Equipment, Engineered Systems, Rental Equipment, Safety Equipment, Service, and Repair.

Mission Statement

Marco provides strong leadership and innovation to the surface preparation and protective coatings industries. We dedicate our efforts to the continuous improvement of our products, services, processes, people, and most importantly, the quality of our customer's experience.

Quality Policy

Marco is committed to providing superior quality in the design, manufacturing, distribution, rental, service, and repair of our products. Our ISO 9001:2008 certification extends throughout all operations in all locations. Continuous improvement of our processes and supply chain Integration comprise the core of our business strategy for delivering exceptional quality and value in all Marco products and services.

Management Philosophy

We are a company dedicated to the success of every customer and associate. We discuss, debate, challenge, measure, and test our ideas. We will be boundless and limitless in our passion to improve. Through sound leadership and dedicated associates, we will ensure a long term, profitable future for Marco, our associates, customers, and suppliers.

TABLE OF CONTENTS

Company Profile	2
Table of Contents	3
Graco® Xtreme® NXT® Passive Fire Protection Single Component Sprayer 4-17	
Part Numbers	4-5
Graco® Xtreme® NXT® Passive Fire Protection Spray Systems	6-7
Cart.	8
Pumpline.	9
Ram Frame.	10-11
20L Platen.	12
Check Valve	13
Static Mixer.	14
Airless Spray Hose	15
Graco® XHF™ Spray Gun	16-17
Maintenance Notes	18-19

PART NUMBERS AND SCHEMATICS GUIDE

Part Numbers	GRACO® XTREME® NXT® PFP SPRAYERS				
	Model	Air Motor	Hoses	Gun	Mount
20G16T311	Xtreme® PFP	NXT®	75 Ft.	XHF™ Gun with 429 Tip	Cart
20G16P957	Xtreme® PFP	NXT®	75 Ft.	XHF™ Gun with 429 Tip	Floor

GRACO® XTREME® NXT® PFP SPRAYERS – SPECIFICATIONS	
Max Fluid Working Pressure	6,500 psi
Pump Lower Output	185cc
Motor	6500 NXT
Max Air Pressure	90 psi
Max Inlet Pressure	100 psi

PART NUMBERS AND SCHEMATICS GUIDE



PART NUMBERS AND SCHEMATICS GUIDE

Graco® Xtreme® NXT® Passive Fire Protection Sprayers

Item #	Part #	Description
Fig. 1		
1	—	Ram, Dual Post Motor Regulator
2	20G100133	3/8" Lock Washer
3	—	Hex Head Cap Screw
4	—	Pump, Xtreme PFP
5	20G160032	Fitting, Nipple
6	20G16T481	Valve, Check
7	20G160327	Fitting, Union Adapter, 90°
11	20GH67550	Hose, Coupled, 3/4" ID, 6500 PSI
12	20G16R883	Fitting, Nipple, Reducing, 3/4" x 1/2"
13	20GH75025	Hose, Coupled, 7250 PSI, 0.50" ID, 25 Ft.
14	20G158491	Fitting, Nipple
15	20G24P834	Swivel, Straight
16	20G262854	Gun, Spray, XHF
18	20G113429	Coupling, Universal, 3/4-14 NPT, Male
19	20G117628	Filter, Air, 3/4 Auto Drain
20	20G157785	Fitting, Swivel
21	20G295847	Fitting, Elbow, 90 Degree, 3/4 MPT
22	—	Adapter, Platen
24	—	Label, Identification
25	20G16P434	Cart, Ram
26	20G113430	3/4-14 NPT (F) Coupling
27	20G238909	Wire, Grounding
—	20G206994	Fluid, TSL, 8 oz bottle (<i>Not Shown</i>)

**Item not available for individual sale*

PART NUMBERS AND SCHEMATICS GUIDE

Figure 1: Graco® Xtreme® NXT® Passive Fire Protection Sprayers

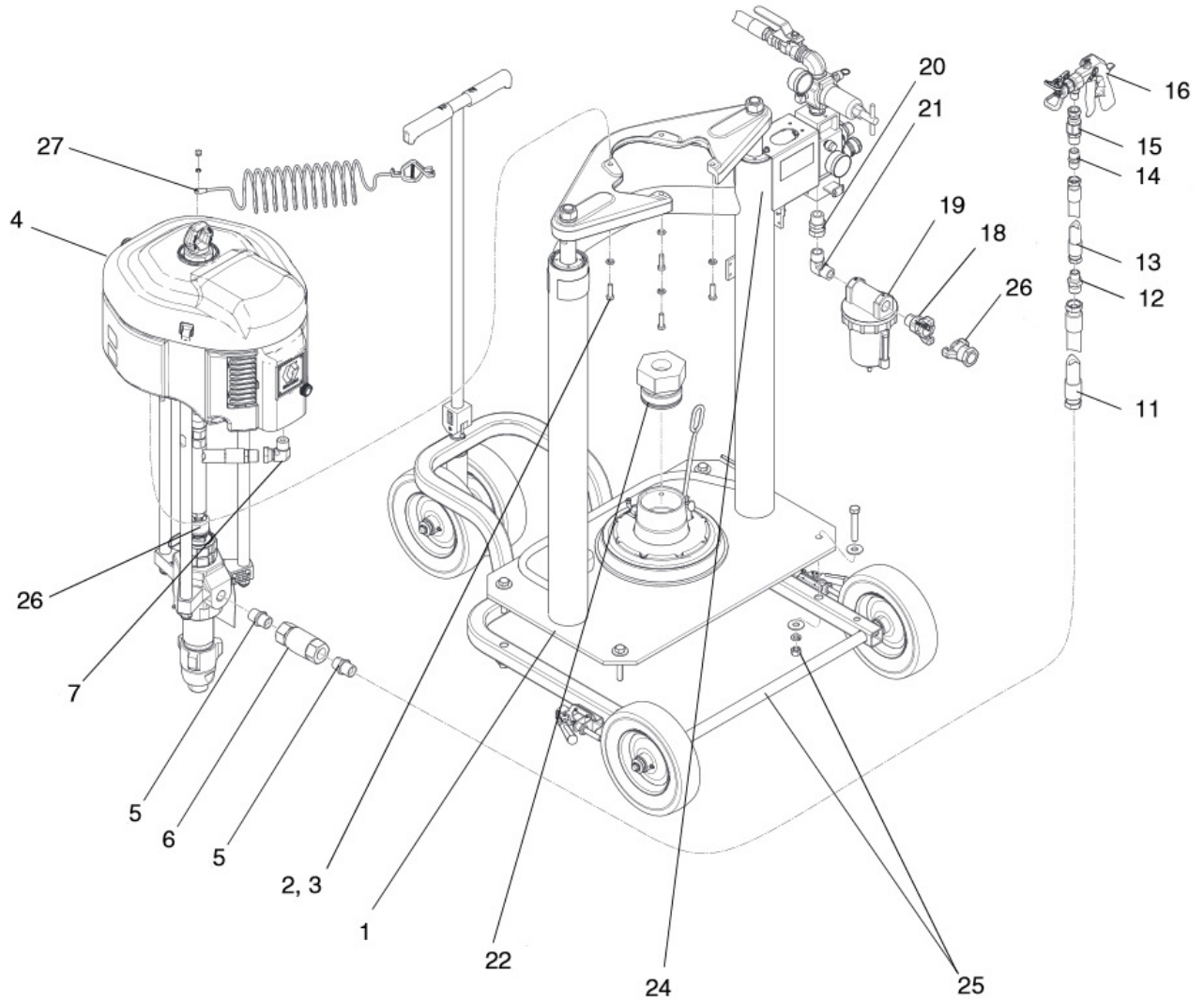

PART NUMBERS AND SCHEMATICS GUIDE

Figure 2: Cart

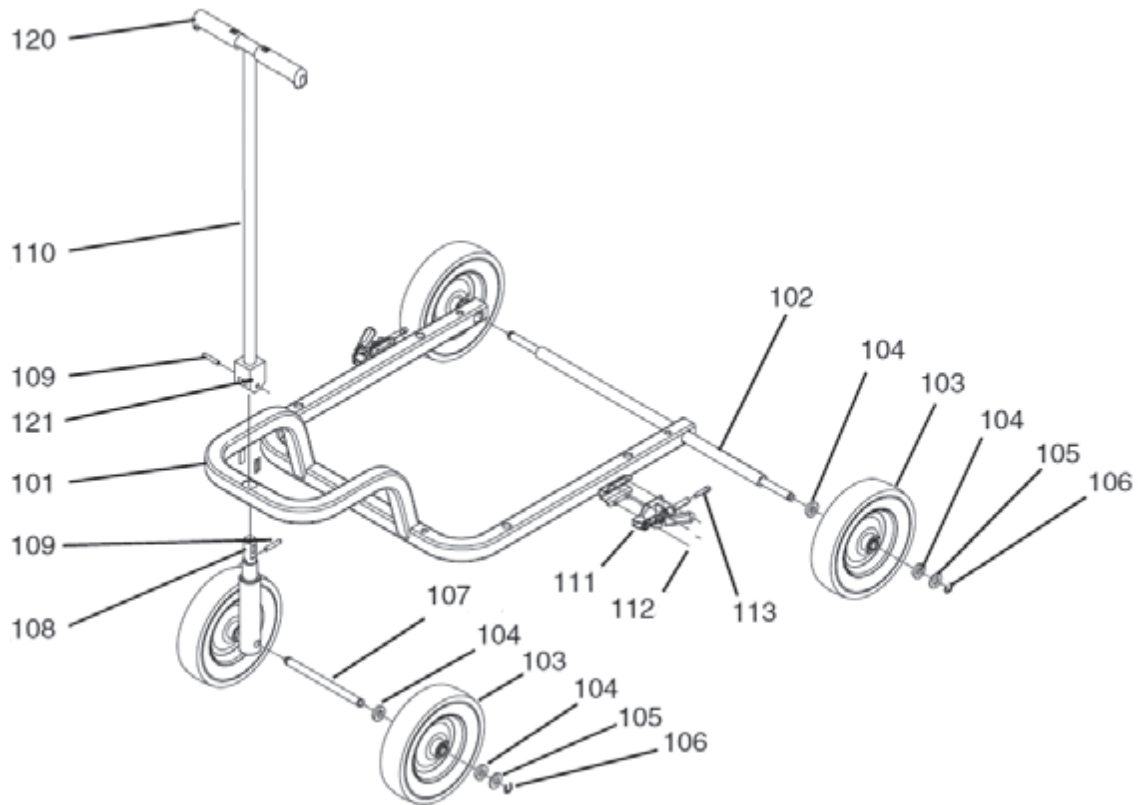

Item #	Part #	Description
Fig. 2		
101	—	Cart
102	—	Axle
103	20G113807	Urethane Wheel, Flat Free
104	20G191824	Space Washer
105	20G111841	5/8" Plain Washer
106	20G101242	External Retaining Ring
107	20G15A913	Axle
108	—	Axle
109	20G124291	Spring Pin
110	20G258982	Cart Handle
111	—	Brake
112	20G112788	Socket Head Cap Screw
113	20G102962	Socket Head Cap Screw
120	20G116139	Handle Grip
121	—	Arrow Label

— Not Available for Individual Sale

PART NUMBERS AND SCHEMATICS GUIDE

Figure 3: Pumpline

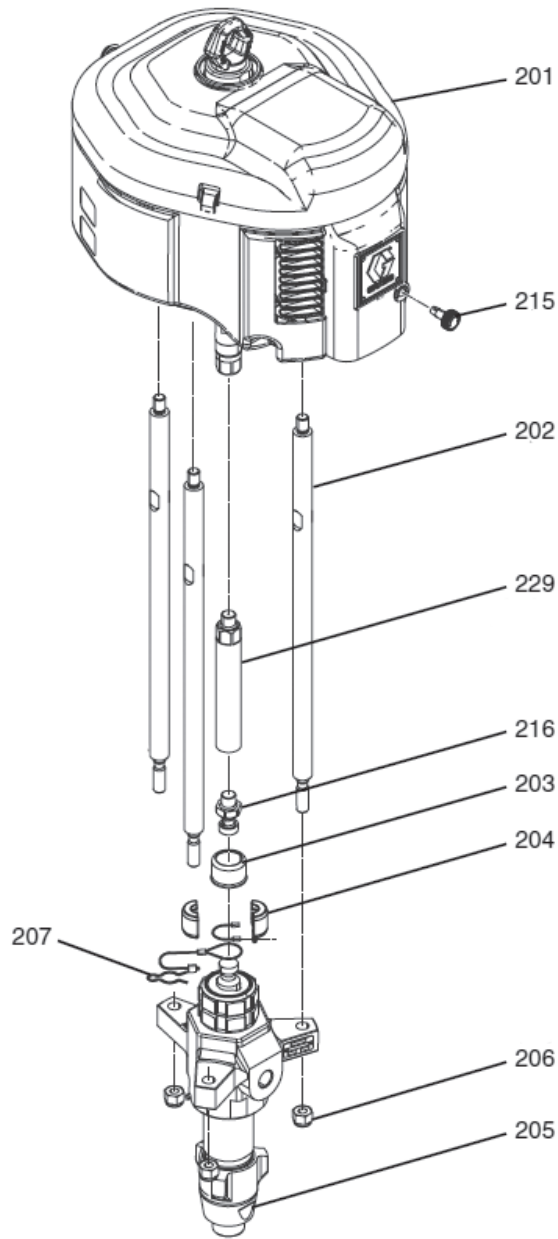

Item #	Part #	Description
Fig. 3		
201	20GN65DN0	6500 NXT® Air Motor
202	—	Tie Rod
203	20G197340	Coupler Cover
204	20G244819	Assembly Coupling
205	20GL180C7	Xtreme Lower
206	20G101712	Lock Nut
207	20G244820	Hairpin Clip with Lanyard
215	20G15J277	De-Ice Control
216	20G15H392	Xtreme Adapter Rod

— Not Available for Individual Sale

PART NUMBERS AND SCHEMATICS GUIDE

Ram Frame

Item #	Part #	Description
Fig. 4		
301	—	Ram Weldment
302	—	Ram Piston Subassembly <i>(Includes Item #'s: 302a – 302p)</i>
302a	—	Ram Piston Rod
302b	20G15M295	Ram End Cap Bearing
302c	20G15U979	Spring Straight Pin
302d	20G160258	O-ring Packing, Buna-n
302e	20G156698	O-ring Packing
302f	20G183943	Piston
302g	20G101535	Full Hex Nut
302h	20H101533	Spring Lock Washer
302j	20G156401	O-ring Packing
302k	—	Ram End Cap Bearing
302l	20G15F453	Retaining Ring Retainer
302m	20G160138	Compression Spring
302n	—	Lubricant, grease
302p	—	Thread Sealant
303	—	Retaining Ring
304	20G255296	Mounted Bracket
305	20G100016	Lock Washer
306	20G101682	Cap Head Socket Screw
307	20G24C824	Ram Air Control, Hydraulic
308	20G297151	Elbow Fitting
310	—	Crush/Pinch Safety Label
312	—	Shutoff Valve Label
313	20GC32467	Drum Stop
314	20GC38185	Lock Washer
315	20GC19853	Socket Head Cap Screw
318	20G16F014	Air Regulator, T-handle
319	20G157785	Swivel Fitting
320	20G100960	Air Pressure Gauge
321	20G103347	Safety Valve, 100 psi
322	—	3/4-14 Street Elbow
323	20G113218	Vented Ball Valve, 0.750
324	20G101689	Air Pressure Gauge
326	20GC20487	Hex Nipple
327	20G100840	Street Elbow
328	20GC12034	Coupled Hose, 72 Inch
331	—	Shelf Bracket, D60, 3400/6500
332	20G101533	Spring Lock Washer
333	20G101535	Full Hex Nut
334	20G198442	Mix Manifold Retaining Strap
335	20G16U676	Plate, 20 L Single Wiper
—	20G257622	Repair Kit <i>Includes Item #'s: 302 (all components), 303, and 310</i>

— Not Available for Individual Sale

PART NUMBERS AND SCHEMATICS GUIDE

Figure 4: Ram Frame

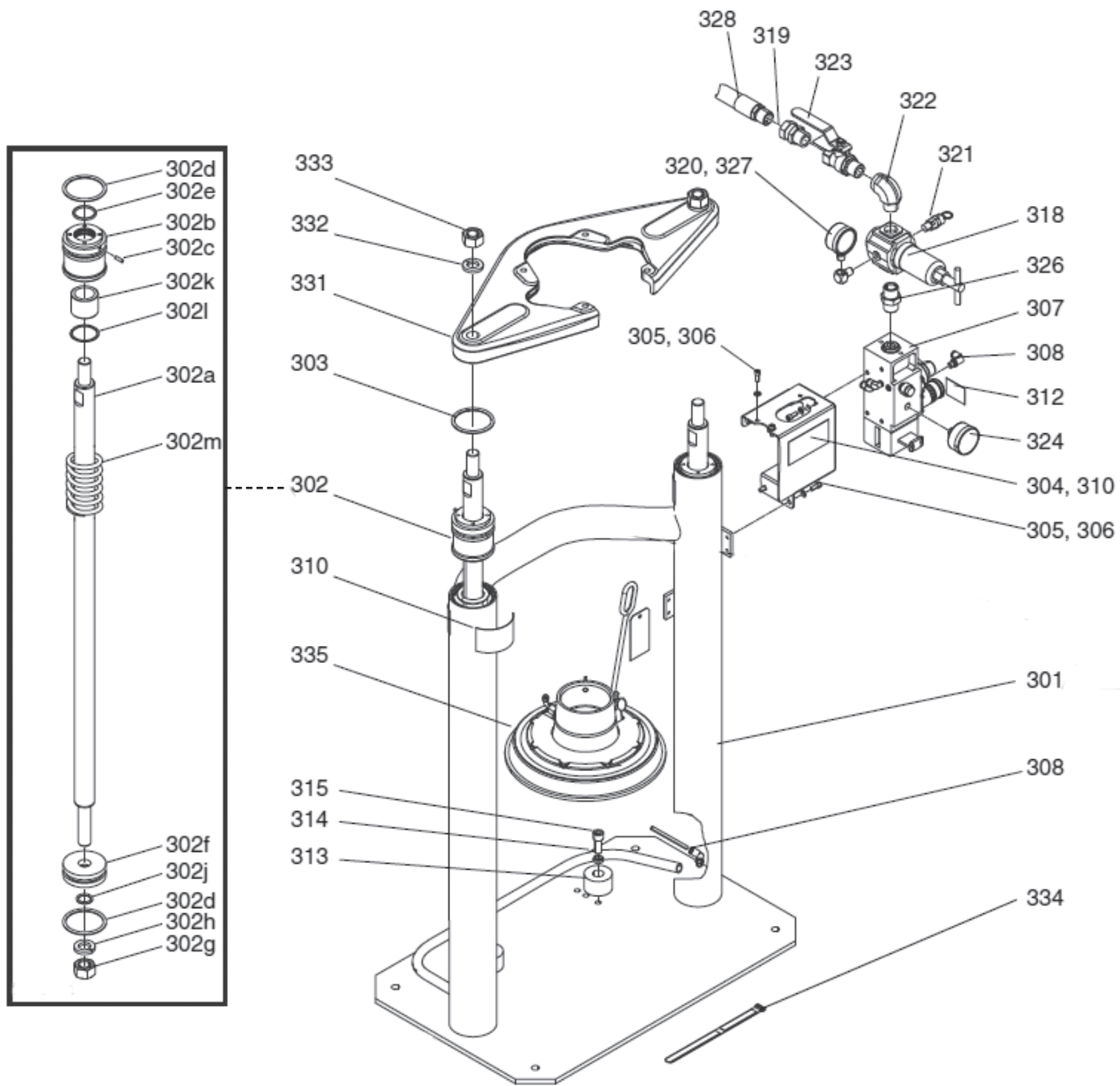

PART NUMBERS AND SCHEMATICS GUIDE

Figure 5: Platen

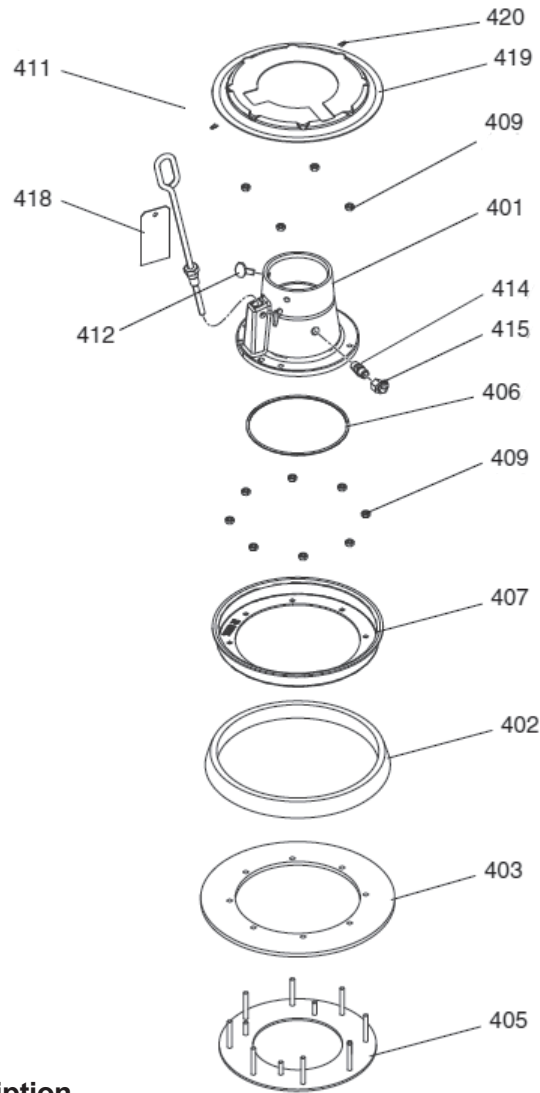

Item #	Part #	Description
Fig. 5		
401	—	20L Platen Base
402	20G276049	Spacer
403	20G262936	Main Wiper
405	—	Platen Bottom Plate
406	20G121829	Packing O-ring, -162
407	—	Clamp Retainer
409	—	1/4-20 Hex Head Keps Nut
411	20G257697	Stainless Steel Bleed Handle
412	—	5/16-18 x 1/2" Carbon Steel Thumb Screw
413	20G112358	O-ring Packing
414	20G122056	Check Valve
415	20GC20350	90° Elbow
418	—	Instruction Tag
419	20G15W184	20L Cover Shroud
420	20G16U740	Hairpin Cotter Pin (<i>Quantity of 10</i>)

— Not Available for Individual Sale

PART NUMBERS AND SCHEMATICS GUIDE

Figure 6: Check Valve

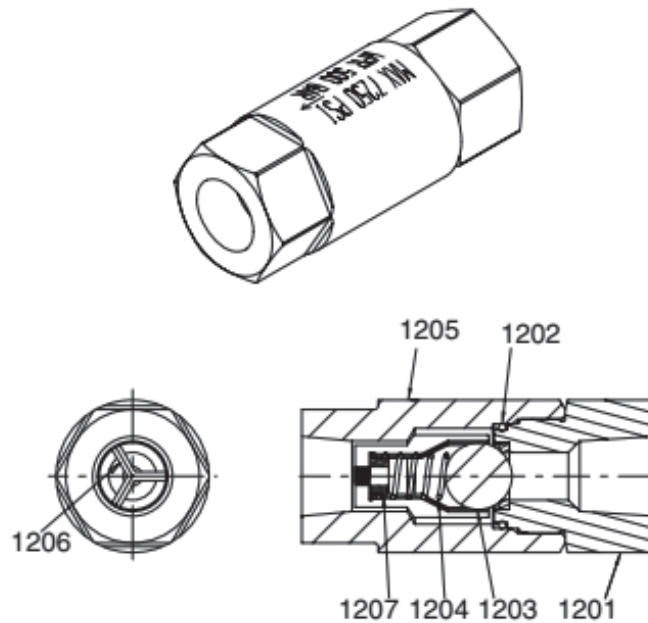

Item #	Part #	Description
Fig. 6		
—	20G16T481	Check Valve, 7250 psi
1201	—	Seat Nut
1202	20G102595	O-Ring Packing
1203	20G100279	Metallic Ball
1204	20G108361	Compression Spring
1205	—	Ball Check Housing
1206	20G181492	Ball Guide
1207	20G181535	Retainer Spring

PART NUMBERS AND SCHEMATICS GUIDE

Figure 7: Static Mixer

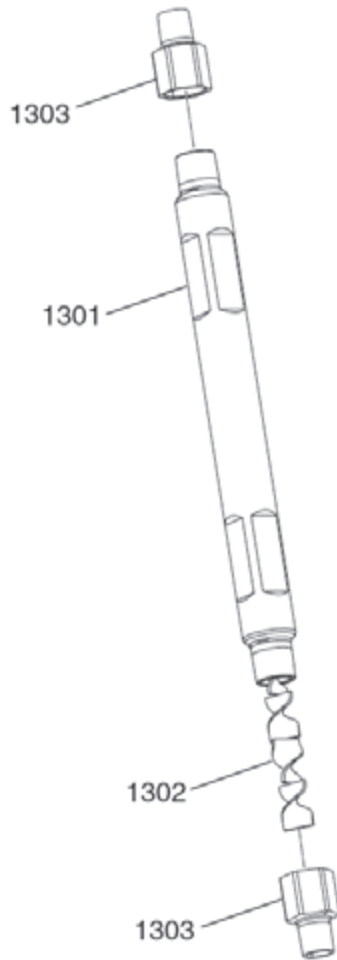

Item #	Part #	Description
Fig. 7		
—	20G16T316	Static Mixer, 12 Element, Stainless Steel
1301	—	Tube Mixer
1302	20G24P886	12 Element, Stainless Steel Mixer
1303	20G16T315	3/4" NPT (F) x 1/2" NPT Reducing Bushing
1304	—	Stainless Steel Pipe Sealant

— Not Available for Individual Sale

PART NUMBERS AND SCHEMATICS GUIDE

		1/2" I.D. AIRLESS SPRAY HOSE – COUPLED					
Part Numbers		Working Pressure	Length (Ft.)	Hose I.D.	Hose Cover Color	Braid Reinforcement Material	Couplings
	2000339	7,250 PSI	25	1/2"	Black	Aramid/Steel	Female x Female
	2000328	7,250 PSI	50	1/2"	Black	Aramid/Steel	Female x Female
	2000331	7,250 PSI	100	1/2"	Black	Aramid/Steel	Female x Female

		3/4" I.D. AIRLESS SPRAY HOSE – COUPLED					
Part Numbers		Working Pressure	Length (Ft.)	Hose I.D.	Hose Cover Color	Braid Reinforcement Material	Couplings
	2000101	6,500 PSI	25	3/4"	Black	Aramid/Steel	Male x Female
	2000100	6,500 PSI	50	3/4"	Black	Aramid/Steel	Male x Female

PART NUMBERS AND SCHEMATICS GUIDE

Graco® XHF™ Spray Gun Assembly

Item #	Part #	Description
Fig. 8		
—	20G262854	Graco® XHF™ 4-Finger Spray Gun with XHD 429 Tip
—	20G24P833	Graco® XHF™ 4-Finger Spray Gun with XHD 429 Tip and 17 Ft. Mix Line Kit, and Static Mixer
1	—	Gun Body*
2	20G237260	Kit <i>Includes: Needle and Seat</i>
2a	—	Valve Seat*
2b	—	Gasket*
2c	—	Needle*
2d	—	Seal Retainer*
2e	—	Seal*
8	20GXHD429	SwitchTip® – Size 429
9	20GXHD001	Kit – RAC™ Guard
13	20G203953	10-24 Hex Head Screw
15	20G102207	1/4-20 Set Screw
16	20G189960	Spring Guide
17	20G112729	Socket Head Set Screw <i>(Two Required)</i>
18	20G189958	Trigger Pin
19	20G112727	Spring
20	20G189990	Spring Adjuster
21	20G110637	Adjusting Screw
22	20G16P780	Fluid Housing
23	20G187965	Pivot Pin
24	20G189974	Gun Trigger
25	20G235468	Trigger Stop
26	20G112410	E-Clip <i>(Two Required)</i>
—	20G237260	Graco® XHF™ Gun Repair Kit
—	20G24P833	1/2" x 3/8" XHF™ Gun Swivel, 6500 psi, PTFE Packing
—	20G187987	Warning Tag
—	20G222385	Warning Card <i>(Not Shown)</i>
—	20G24P834	Graco® XHF Spray Gun Swivel, 1/2" x 3/8" NPSM, PTFE Packing
—	20G237260	Graco® XHF Spray Gun Repair Kit
—	209V500	Operator's Manual – Graco® XHF Spray Gun

*Item not for Individual Sale

PART NUMBERS AND SCHEMATICS GUIDE

Figure 8: Graco® XHF™ Spray Gun Assembly

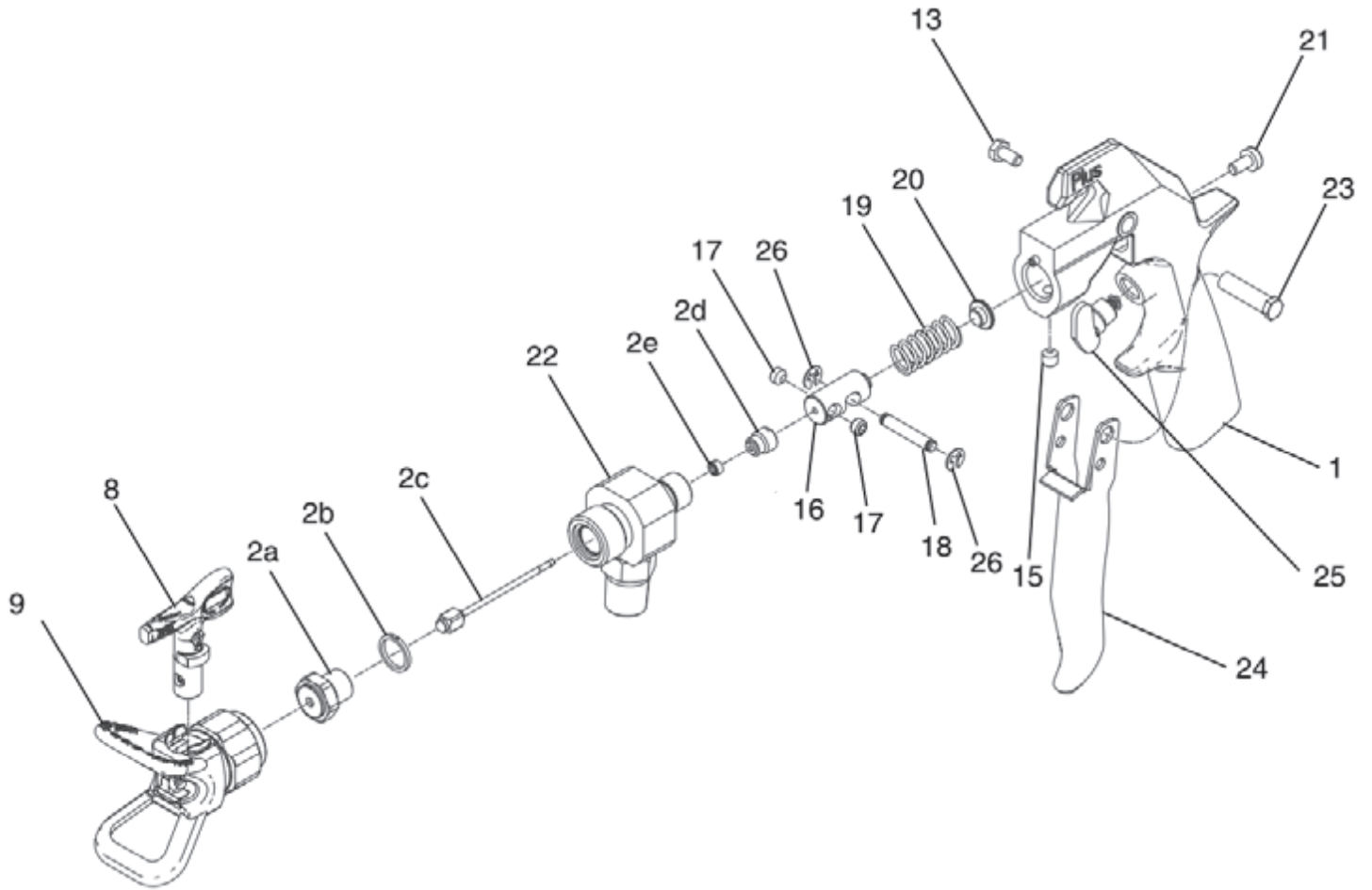

CONTACT CENTER

- 3425 East Locust Street
Davenport, IA 52803

ph: 800.BLAST.IT (800.252.7848)

ph: 563.324.2519

fax: 563.324.6258

REGIONAL BRANCH OFFICES

- **Iowa**
Davenport
- **Louisiana**
Gonzales
Lafayette
- **Ohio**
Youngstown
- **Texas**
Beaumont
Corpus Christi
Deer Park

40+ NATIONWIDE SHIPPING LOCATIONS



★ Marco Regional Branch Offices
and Shipping Locations

● Direct Shipping Locations



ABRASIVES

BLASTING

COATING

DUST COLLECTORS

ENGINEERED SYSTEMS

RENTAL

SAFETY

SERVICE & REPAIR

VACUUMS

CONTACT MARCO

800.BLAST.IT

(800.252.7848)

563.324.2519

FAX: 563.324.6258

WWW.MARCO.US

SALES@MARCO.US