



# GRACO® XTREME® 60:1 AIRLESS SPRAY PUMPS



**PART NUMBERS AND SCHEMATICS GUIDE**

## Company Profile

Since 1944, Marco has developed a strong tradition of providing innovative and reliable products and services to the surface preparation and protective coatings industries. We are the world's premier provider of Abrasives, Blasting Equipment, Coating Equipment, Engineered Systems, Rental Equipment, Safety Equipment, Service, and Repair.

Through innovative designs and a total commitment to quality, Marco manufactures products that increase production rates, create a safer workplace, and reduce maintenance costs. Marco's industry experience, manufacturing capabilities, legendary customer service, product availability, logistics services, and technology leadership is your assurance that we deliver high quality products and services, providing the best value to you, our customer.

## The Marco Difference

- **Industry Experience** – With Marco on your team, you have access to expertise which can only come from decades of industry leadership. We have organized our engineering department, production specialists, customer operations, and safety support into a “Center of Competence.” As a Marco customer, you have access to hundreds of years of cumulative experience related to your operations.
- **Manufacturing Excellence** – Marco is a U.S. based, ISO 9001:2008 certified manufacturer of equipment for the Surface Preparation and Protective Coatings industries. Marco's engineers benchmark the industry to ensure that we design and manufacture superior products that set the “Gold Standard” for performance, safety, and quality.
- **Legendary Customer Service** – Marco's legendary customer service team is staffed by friendly, highly-trained individuals who are focused on providing the highest level of product support, order accuracy, and customer satisfaction.
- **Product Availability** – We stock over 10,000 SKU's and have over 45 shipping locations to serve North American and International markets for all major brands of blasting and painting equipment. As the largest provider of surface preparation and protective coatings equipment in the world, our inventory levels and product availability are unmatched.
- **Logistics Services** – Marco's in-house logistics team is dedicated to moving your shipment anywhere in the world. We move over 14,000 truckloads every year, allowing you to save on freight costs by leveraging our buying power. Lower your process costs with a single invoice, which includes product and freight.
- **Technology Leadership** – Our website provides: Operator's Manuals, Part Numbers and Schematics Guides, MSDS information, and Features and Specifications Guides, providing access to information 24/7. Our Extranet application allows you to receive quotes and place orders online. Our Intranet maintains a complete record of your purchase history to assist with ongoing support of your existing equipment and future purchasing decisions.

## Vision Statement

Marco is the world's premier provider of Abrasives, Blasting Equipment, Coating Equipment, Engineered Systems, Rental Equipment, Safety Equipment, Service, and Repair.

## Mission Statement

Marco provides strong leadership and innovation to the surface preparation and protective coatings industries. We dedicate our efforts to the continuous improvement of our products, services, processes, people, and most importantly, the quality of our customer's experience.

## Quality Policy

Marco is committed to providing superior quality in the design, manufacturing, distribution, rental, service, and repair of our products. Our ISO 9001:2008 certification extends throughout all operations in all locations. Continuous improvement of our processes and supply chain Integration comprise the core of our business strategy for delivering exceptional quality and value in all Marco products and services.

## Management Philosophy

We are a company dedicated to the success of every customer and associate. We discuss, debate, challenge, measure, and test our ideas. We will be boundless and limitless in our passion to improve. Through sound leadership and dedicated associates, we will ensure a long term, profitable future for Marco, our associates, customers, and suppliers.

# TABLE OF CONTENTS

<b>Company Profile</b> .....	<b>2</b>
<b>Table of Contents</b> .....	<b>3</b>
<b>Graco® Xtreme® 60:1 Airless Spray Pumps</b> .....	<b>4-18</b>
Graco® Xtreme® 60:1 Airless Spray Pumps .....	4-5
Xtreme® Airless Sprayers.....	6-7
NXT® Model 6500 Air Motor and Exhaust.....	8-9
220cc Lower Displacement Pump Repair Parts .....	10-11
Xtreme® Seals Repair Kits .....	12-13
Tuff-Stack™ Repair Kits.....	14-15
X-Tuff® Repair Kits.....	16-17
Filter Cap Series Key.....	18
<b>Optional Accessories</b> .....	<b>19-21</b>
Suction Tubes and Accessories.....	19
High Pressure Ball Valves .....	19
Xtreme® Airless Sprayer Stainless Steel Hopper .....	20-21
<b>Maintenance Notes</b> .....	<b>22-23</b>

## PART NUMBERS AND SCHEMATICS GUIDE

Part Numbers	GRACO® XTREME® 60:1 AIRLESS SPRAYERS								
	MOUNT			Built-In Filter	DataTrak™	Hopper Included	XTR™ 7 Airless Spray Gun	HOSES	
	Heavy-Duty Cart	Light-Weight Cart	Wall Mount					50 Feet x 3/8" I.D. Airless Spray Hose	6 Feet x 1/4" I.D. Airless Spray Hose
20GX60DH4	X			X					
20GX60DH2	X			X	X				
20GX60DH3	X			X			X	X	X
20GX60DH6	X			X		X	X	X	X
20GX60DH1	X			X	X		X	X	X
20GX60DH5	X			X	X	X	X	X	X
20GX60DH7	X						X	X	X
20GX60DL4		X		X					
20GX60DL2		X		X	X				
20GX60DL6		X		X		X	X	X	X
20GX60DL3		X		X			X	X	X
20GX60DL1		X		X	X		X	X	X
20GX60DL5		X		X	X	X	X	X	X
20GX60DW4			X	X					
20GX60DW2			X	X	X				

GRACO® XTREME® 60:1 AIRLESS SPRAYER – SPECIFICATIONS	
Output Per Cycle	6,000 psi
Pump Lower Output per Cycle	220cc
Motor	NXT 6500cc
De-Icing Motor	Yes
Xtreme® Seal and Leather Packing	Yes

## PART NUMBERS AND SCHEMATICS GUIDE



*\*20GX60DH4 Shown*

## PART NUMBERS AND SCHEMATICS GUIDE

### Graco® Xtreme® 60:1 Airless Spray Pumps

Item#	Part#	Description
<b>Fig. 1</b>		
2	20G287884	Heavy-Duty Cart
—	20G287919	Lightweight Cart
3	20G197682	1" Suction Tube
4	20G247301	1" NPT x Quick Connect, 6 ft. Suction Hose
—	20G288687	1" NPT x Quick Connect, 10 ft. Suction Hose ( <i>Wall-Mount Units</i> )
5	20G116401	Elbow Adapter
6	20G116402	Quick Connect Adapter
7	20G244524	Ground Assembly Wire with Clamp
10	20G181072	Strainer Inlet
11	20G100101	Hex Head Cap Mounting Screw
12	20G100133	Lock Washer
13	20G247312	Adapter Kit Plate
—		<i>(Includes Lock Nut and Adapter Plate)</i>
14	20G24E013	Air Control ( <i>Heavy Duty Cart</i> )
18	20G162505	1/2" F x 3/8" M Swivel Union Fitting
101	20GXTR704	XTR™ 7 Spray Gun for 55:1 – 90:1 ratio only ( <i>Not included with all models, see page 4</i> )
102	20GH52506*	Fluid Hose (Nylon, 1/4" I.D. x 1/4" NPS (M), 6 ft.), 6100 psi
103	20GH53850*	Fluid Hose (Nylon, 3/8" I.D. x 3/8" NPS (M), 50 ft.), 5800 psi
104	20G164856	3/8" x 1/4" NPT Reducing Nipple Fitting
301	—	Spray Pump ( <i>See page 4</i> )
302	—	Pump Lower ( <i>See pages 10-17</i> )
303	—	NXT® Air Motor ( <i>See pages 8-9</i> )
—	206M540	Part Numbers and Schematics Guide – Graco® Xtreme® 60:1 Airless Spray Pumps
—	206M362	Part Numbers and Schematics Guide – Graco® XTR™ 7 Airless Spray Gun
—	209V508	Operator's Manual – Graco® Xtreme® Pump Packages

\*Not included with all models, see page 4



# PART NUMBERS AND SCHEMATICS GUIDE

Figure 1: Graco® Xtreme® 60:1 Airless Spray Pumps

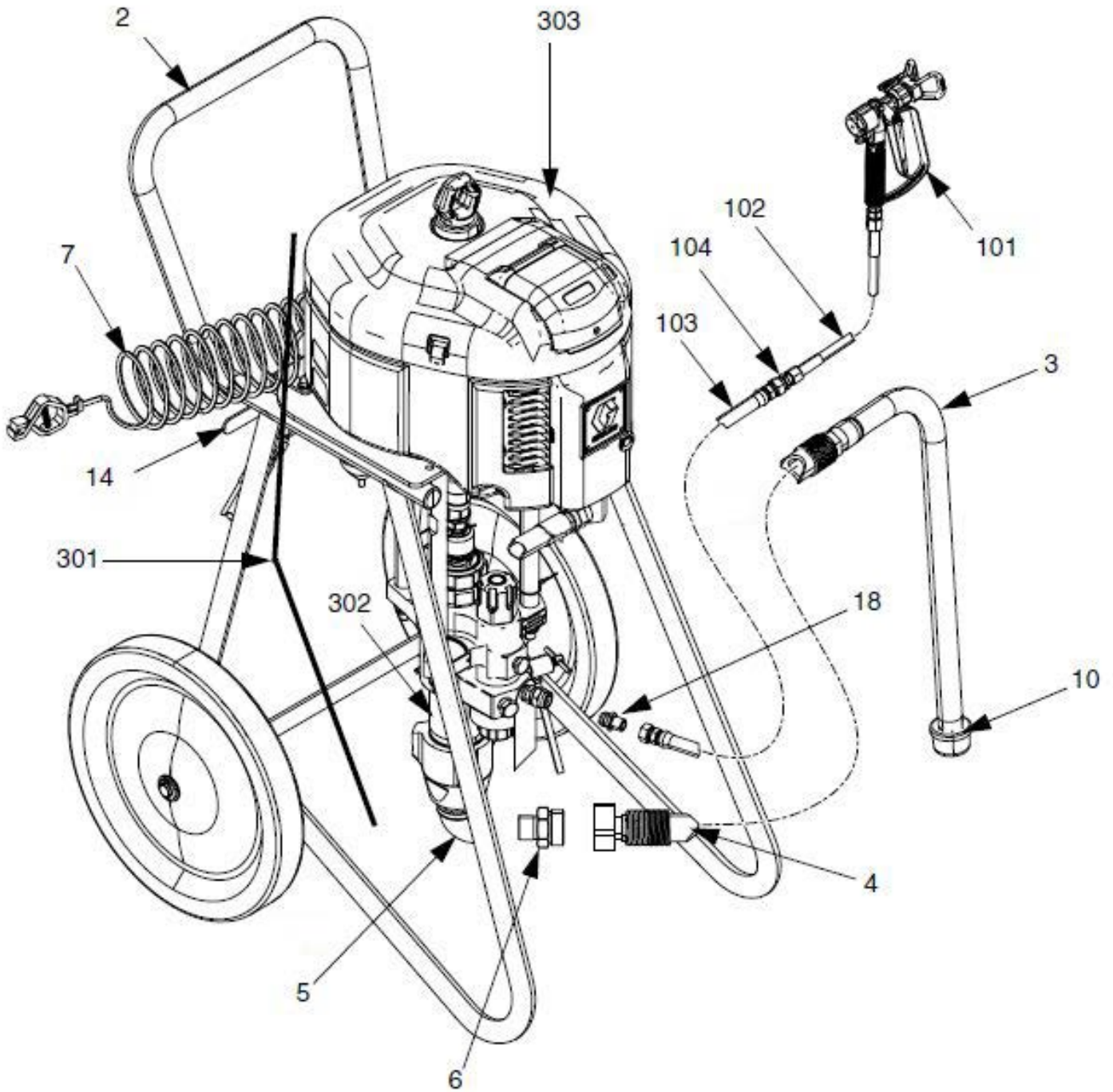

## PART NUMBERS AND SCHEMATICS GUIDE

### NXT® Model 6500 Air Motor and Exhaust

Item#	Part#	Description	Item#	Part#	Description
<b>Fig. 2</b>			43	20G120091	1/4-20 x 2" Screw, Thread Forming, (51 mm)
—	<b>20GN65DN0</b>	<b>NXT® Model 6500 De-Icing Air Motor</b>	44	20G120092	1/4-20 x 2-1/2" Thread Forming Screw, (63 mm)
—	<b>20GN65DH0</b>	<b>NXT® Model 6500 De-Icing Air Motor with Sensor</b>	46	20G253476	Gasket
—	<b>20GN65LN0</b>	<b>NXT® Model 6500 Low Noise Motor</b>	47	20G287844	Valve Cover, Outer
1	20G15F953	Top Cover	51	20G15F674	Safety Label
2	20GNXT604	Cylinder	52	20G15F973	Safety Label
3	20GNXT602	Bottom Cover	54	20G15H179	Deflector
4	20GNXT601	Piston Assembly	55	20G107257	1/4-20 x 1/2" Thread Forming Screw, (13 mm)
7	20G161562	Packing, V-block; Nitrile	56	20G15H190	Exhaust Seal
8	20G15H610	Packing, Backup; Leather	57	20G15K345	Gasket, buna-N
9	20G16A026	Retaining Ring	58	20G120206	Poppet Muffler
10	20GNXT106	Piston Bumper, includes Magnet	59	20G277366	Bumper
12	20GNXT100	Poppet <i>(Includes Item #'s: 12a-12d)</i>	60	20G116343	Ground Screw, M5 x 0.8
12a	—	O-Ring, buna-N	61	20G111307	Lock Washer, 5 mm
12b	20GNXT101	O-Ring, buna-N	62	20GNXT112	De-Ice Knob
12c	20GNXT101	O-Ring, Backup, buna-N	63	20G15G689	Exhaust Diffuser
12d	—	O-Ring, buna-N	—	20GNXT600	Repair Kit NXT 6500 Air Motor <i>(Includes Item #'s: 7, 8, 9, 17, 18, and 46)</i>
13	20G119050	1/2-13 x 8" Hex Head Bolt, (203 mm)	—	209V509	Operator's Manual – Graco® NXT® Air Motor
14	20G15F639	1/2-13 Nut with Lock Washer			
15	20GNXT603	Muffler			
17	20G122675	Piston O-Ring, Nitrile			
18	20G15F448	End Cap O-Ring, Nitrile			
20	20G119990	O-Ring, buna-N			
21	20G15F931	Lift Ring			
22	20GNXT110	De-Ice Exhaust Kit <i>(Includes Item #'s: 20, 25, 44, 56, and 57)</i>			
23	20GNXT105	Remote Exhaust Kit <i>(Includes items 20, 44)</i>			
24	20GNXT104	Low Noise Exhaust Kit <i>(Includes item #'s: 20, 22, 25, 44, 54, 55, 56, and 57)</i>			
25	20G120730	1/4-20 x 1" Machine Screw, Hex Head, (25 mm)			
41	20G120088	3/8-16 x 4" Screw (101 mm)			



# PART NUMBERS AND SCHEMATICS GUIDE

Figure 3: NXT® Model 6500 Air Motor and Exhaust

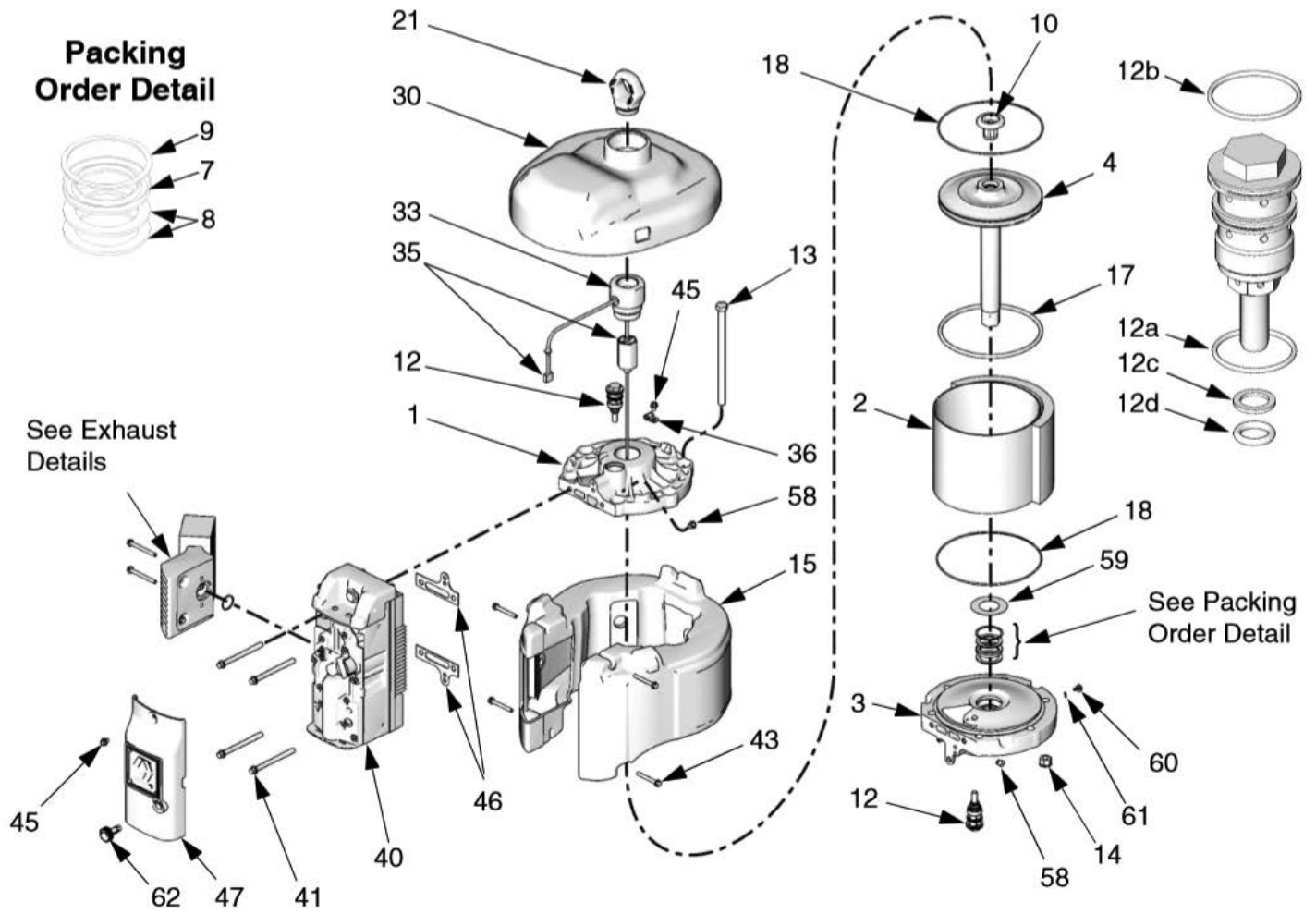

## Low Noise Exhaust

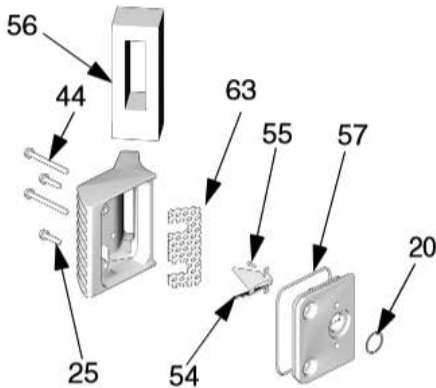

## De-Ice Exhaust

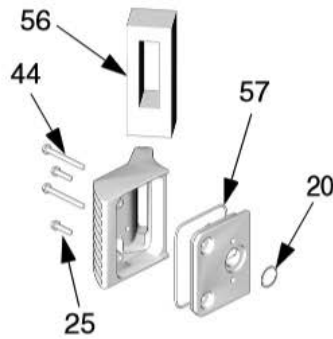

## Remote Exhaust

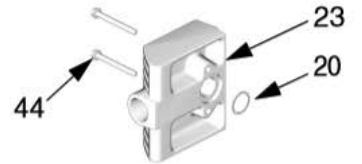

## PART NUMBERS AND SCHEMATICS GUIDE

### 220cc Xtreme® Sprayer Lower Displacement Pump

Item#	20GL220C1 (No Built-In Filter)	20GL220C2 (Built-In Filter)	Description
<b>Fig. 3</b>			
1	20G24B823	20G24B823	Displacement Rod
2	20G15K031	20G15K031	Packing Nut
3*	—	—	Stack Packings, Throat (See Repair Kits, Fig. 5, 6, 7)
4*	—	—	Stack Packings, Piston (See Repair Kits, Fig. 5, 6, 7)
7	20G197327	20G197327	Packing Cartridge, Throat
8	20G197335	20G197337	Housing Outlet
9*	20G244893	20G244893	O-Ring, Top Cylinder, PTFE Medium (Quantity of 10)
10	20G244826	20G244826	Self-Locking Pin
11	20G197317	20G197317	Lower Cylinder
12	20G244898	20G244898	Ball Piston (Quantity of Three)
13	20G24B828	20G24B828	Piston Valve
14	20G197304	20G197304	Inlet Housing
15	20G198647	20G198647	Inlet Ball Guide
16*	20G253030	20G253030	Inlet Ball (Quantity of Three)
17	20G244856	20G244856	Inlet Shim Ball Guide (Quantity of Nine)
18	20G197344	20G197344	Inlet Seat
19*	20G247395	20G247395	Throat Seal Plug (Quantity of 10)
20	—	20G16M461	Top Filler Cap
21	—	20G171941	Compression Spring
22*	—	20G244895	Thin Filter O-Ring, PTFE (Quantity of 10)
23	—	20G224459	Strainer, 60 mesh screen
24	—	20G186075	Filter Support
25*	—	20G262484	Filter O-Ring, Medium, PTFE (Quantity of 10)
26	—	20G16M462	Lower Filter Cap
27*	20G244894	20G244894	Foot Valve and Cylinder Bottom O-Ring, PTFE thin (Quantity of 10)
30	20G172479	20G172479	Warning Tag
32*	20G244891	20G244891	Throat Cartridge O-Ring, PTFE thin (Quantity of 10)
38	—	20G158491	Nipple Fitting, Outlet, 1/2 in
39	—	20G24N518	Packless Plug, 1/2 in
40	—	20G245143	Pressure Dump Valve
41	—	20G116746	Barbed Fitting, Plated
42	—	20G116750	Nylon Tube
49	20G101754	20G198292	Pipe Plug
55	—	—	Rupture Disc Housing
59*	—	20G262483	Filter O-Ring, PTFE thick (Quantity of 10)

\*Quantities listed with repair kit are number of individual pieces.

# PART NUMBERS AND SCHEMATICS GUIDE

Figure 3: 220cc Xtreme® Sprayer Lower Displacement Pump

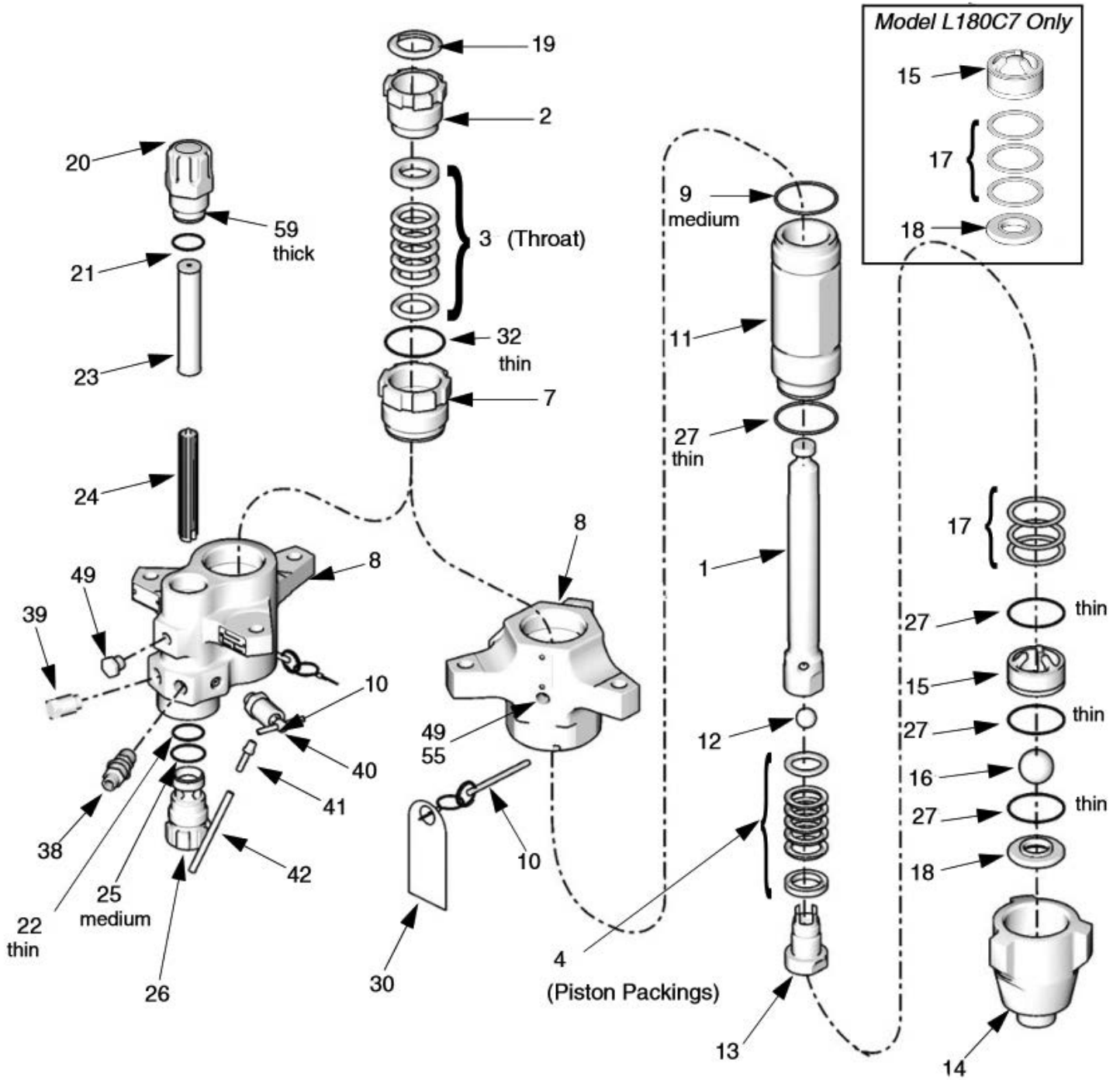

Note: Lower Displacement Pump with Built-In Filter Shown.

## PART NUMBERS AND SCHEMATICS GUIDE

### Xtreme® Seal Repair Kits for 220cc Lower Displacement Pump

Item#	Part#	Description
<b>Fig. 4</b>		
—	<b>20G24F967</b>	<b>Xtreme® Seal Repair Kit</b> <i>(Includes Item #'s: 1 (Quantity of Two); 2 (Quantity of Two); 3 (Quantity of Four); 4 (Quantity of Six); 5 (Quantity of Four); 6 (Quantity of Two); 7, 8, 9, 10 (Quantity of Three); and 11)</i>
103	—	Throat Packings
103a	20G244883	Male Gland <i>(Quantity of Four)</i>
103b	20G244877	Female Gland <i>(Quantity of Four)</i>
103c	20G244871	V-Packing, Leather <i>(Quantity of 10)</i>
103d	20G244865	V-Packing, UHMWPE, Black <i>(Quantity of 10)</i>
104	—	<i>Piston Packings</i>
104a	20G244884	Male Gland <i>(Quantity of Four)</i>
104b	20G244878	Female Gland <i>(Quantity of Four)</i>
104c	20G244872	V-Packing, Leather <i>(Quantity of 10)</i>
104d	20G244866	V-Packing, UHMWPE, Black <i>(Quantity of 10)</i>
109	20G244893	PTFE O-Ring, Top Cylinder Medium <i>(Quantity of 10)</i>
112	20G244898	Ball Piston, 7/8 in (22 mm) <i>(Quantity of Three)</i>
116	20G253030	Ball Inlet, 1.5 in (38 mm) <i>(Quantity of Three)</i>
117	20G244856	Shim Inlet, Ball Guide <i>(Quantity of Nine)</i>
119	20G244999	Throat Seal Plug, 1-3/4 in <i>(Quantity of 10)</i>
—	20G247395	Throat Seal Plug, 2-1/2 in <i>(Quantity of 10)</i>
122	20G244895	Filter O-Ring, Thin, PTFE <i>(Quantity of 10)</i>
123	20G238436	Strainer, 30 mesh screen, 5.65 in <i>(Quantity of 25)</i>
—	20G224458	Strainer, 30 mesh, 5.65 in <i>(Quantity of Two)</i>
—	20G238438	Strainer, 60 mesh, 5.65 in <i>(Quantity of 25)</i>
—	20G224459	Strainer, 60 mesh, 5.65 in <i>(Quantity of Two)</i>
125	20G262484	Filter O-Ring, Medium, PTFE <i>(Quantity of 10)</i>
—	20G244896	Filter O-Ring For Series A Pumps <i>(Quantity of 10)</i>
127	20G244894	O-Ring, PTFE, Thin <i>(Quantity of 10)</i>
143	20G116802	Foot Valve Spring (20G262793 only)
159	20G262483	Top Cap O-Ring, PTFE <i>(Quantity of 10)</i>
—	20G244895	Top Cap O-Ring For Series A Pumps <i>(Quantity of 10)</i>
—	209V021	Operator's Manual — Graco® Xtreme® Pump Lowers

# PART NUMBERS AND SCHEMATICS GUIDE

Figure 4: Xtreme® Seal Repair Kits for 220cc Lower Displacement Pump

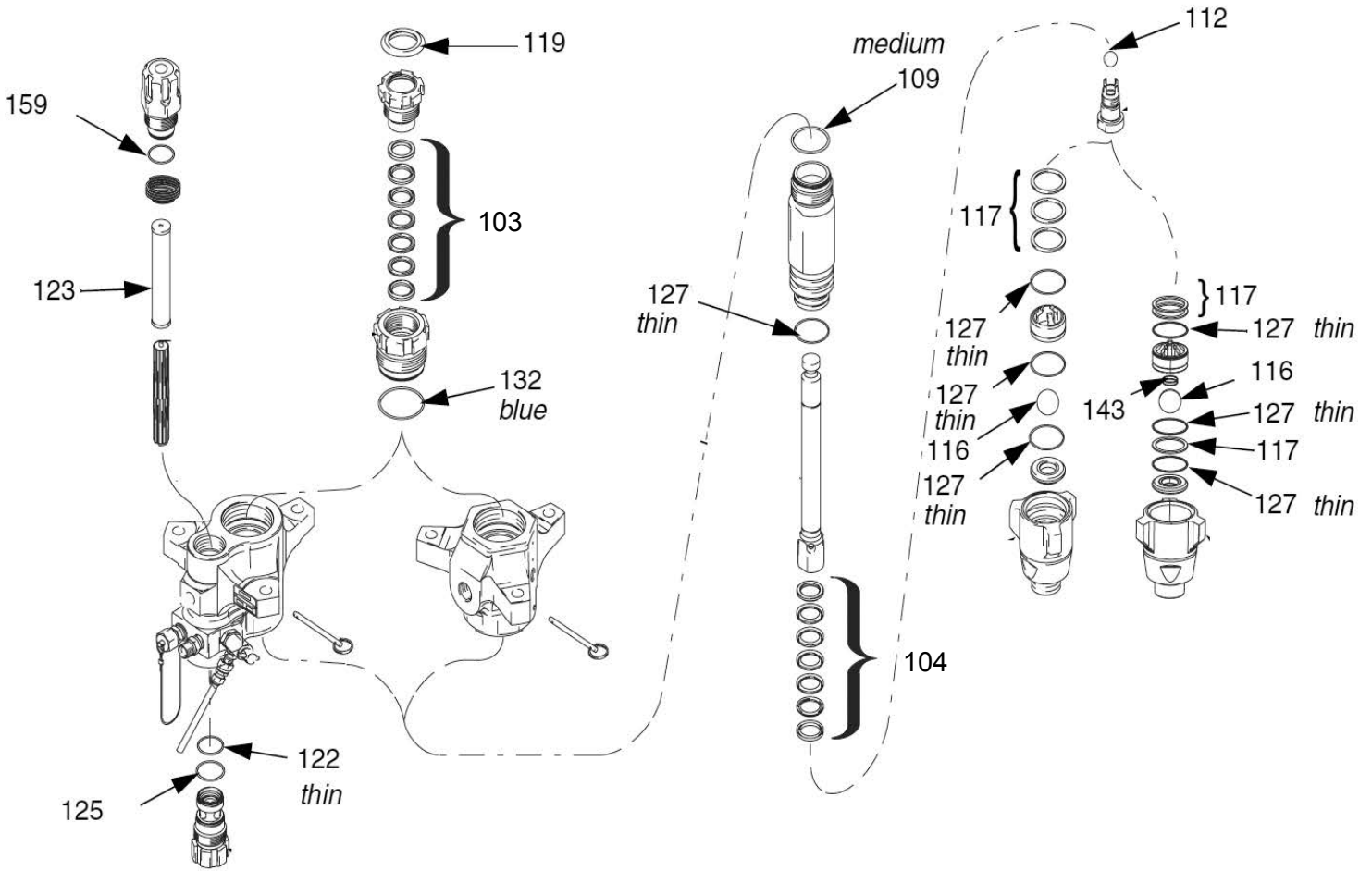

## Xtreme™ Seal Repair Kit 24F967

**Throat Packings:  
Lips Face Down**

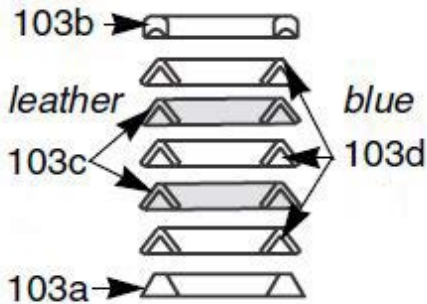

**Piston Packings:  
Lips Face Up**

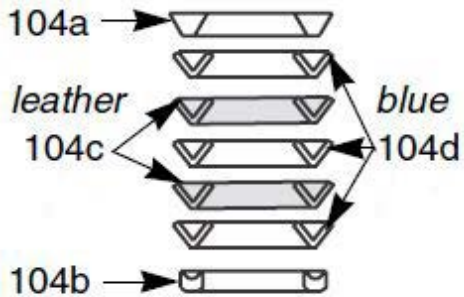



## PART NUMBERS AND SCHEMATICS GUIDE

### Tuff-Stack™ Repair Kit for 220cc Lower Displacement Pump

Item#	Part#	Description
<b>Fig. 5</b>		
—	<b>20G24F968</b>	<b>Tuff-Stack™ Repair Kit</b> <i>(Includes Item #'s: 1 (Quantity of Two); 2 (Quantity of Two); 3 (Quantity of Four); 4 (Quantity of 10); 5 (Quantity of Two); 6 (Quantity of Four); 7, 8, 9 (Quantity of Three); and 10)</i>
103	—	Throat Packings
103a	20G244883	Male Gland <i>(Quantity of Four)</i>
103b	20G244877	Female Gland <i>(Quantity of Four)</i>
103e	20G244859	V-Packing Carbon-Filled, PTFE/UHMWPE, Blue <i>(Quantity of 10)</i>
104	—	Piston Packings
104a	20G244884	Male Gland <i>(Quantity of Four)</i>
104b	20G244878	Female Gland <i>(Quantity of Four)</i>
104e	20G244860	V-Packing Carbon-Filled, PTFE/UHMWPE, Blue <i>(Quantity of 10)</i>
109	20G244893	PTFE O-Ring, Top Cylinder Medium <i>(Quantity of 10)</i>
112	20G244898	Ball Piston, 7/8 in (22 mm) <i>(Quantity of Three)</i>
116	20G253030	Ball Inlet, 1.5 in (38 mm) <i>(Quantity of Three)</i>
117	20G244856	Shim Inlet, Ball Guide <i>(Quantity of Nine)</i>
119	20G244999	Throat Seal Plug, 1-3/4 in <i>(Quantity of 10)</i>
—	20G247395	Throat Seal Plug, 2-1/2 in <i>(Quantity of 10)</i>
122	20G244895	Filter O-Ring, Thin, PTFE <i>(Quantity of 10)</i>
123	20G238436	Strainer, 30 mesh screen, 5.65 in <i>(Quantity of 25)</i>
—	20G224458	Strainer, 30 mesh, 5.65 in <i>(Quantity of Two)</i>
—	20G238438	Strainer, 60 mesh, 5.65 in <i>(Quantity of 25)</i>
—	20G224459	Strainer, 60 mesh, 5.65 in <i>(Quantity of Two)</i>
125	20G262484	Filter O-Ring, Medium, PTFE <i>(Quantity of 10)</i>
—	20G244896	Filter O-Ring For Series A Pumps <i>(Quantity of 10)</i>
127	20G244894	O-Ring, PTFE, Thin <i>(Quantity of 10)</i>
143	20G116802	Foot Valve Spring (20G262793 only)
159	20G262483	Top Cap O-Ring, PTFE <i>(Quantity of 10)</i>
—	20G244895	Top Cap O-Ring For Series A Pumps <i>(Quantity of 10)</i>
—	209V021	Operator's Manual — Graco® Xtreme® Pump Lowers



# PART NUMBERS AND SCHEMATICS GUIDE

Figure 5: Tuff-Stack™ Repair Kit for 220cc Lower Displacement Pump

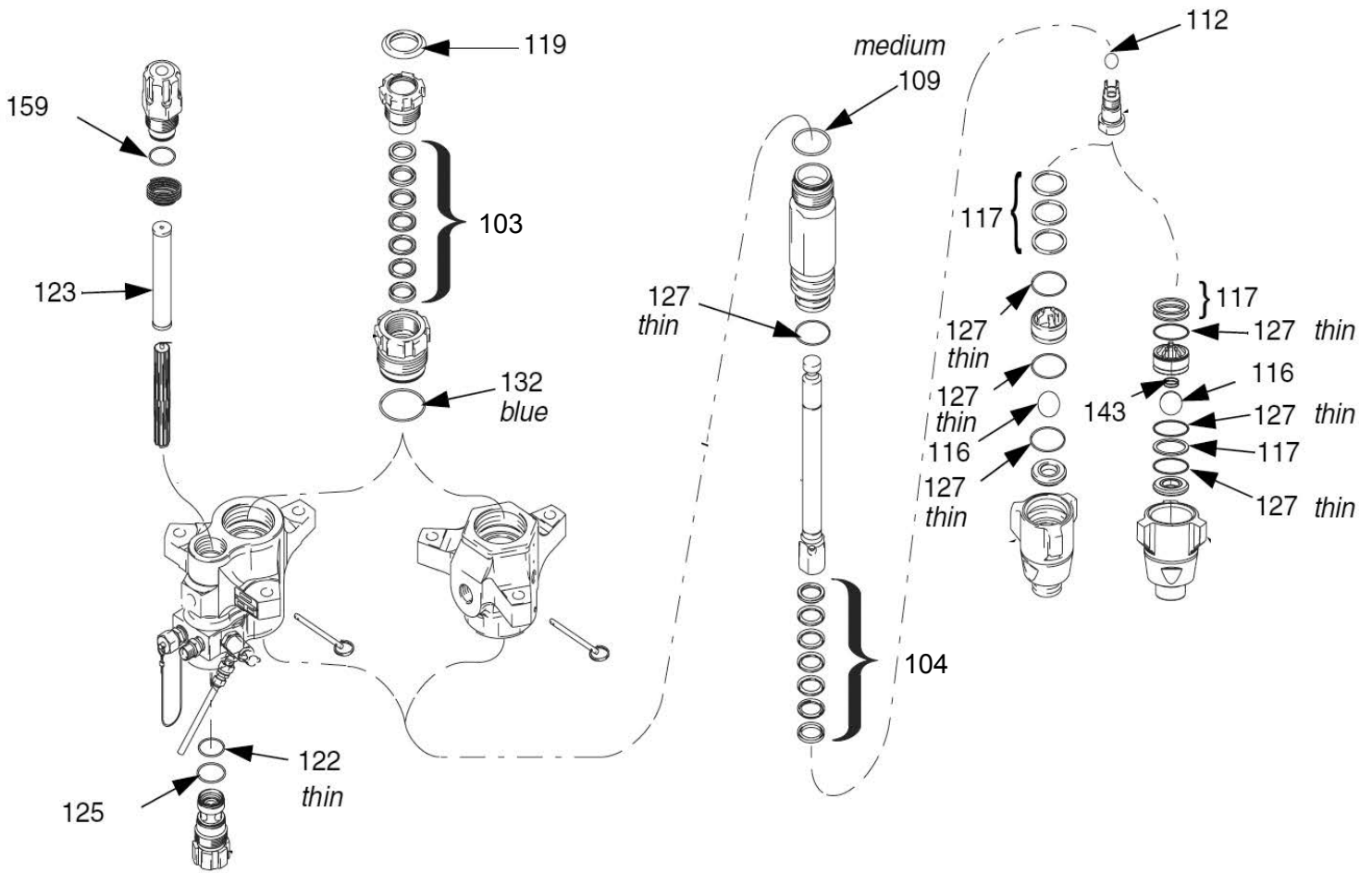

## Tuff-Stack™ Seal Repair Kit

**Throat Packings:  
Lips Face Down**

**Piston Packings:  
Lips Face Up**

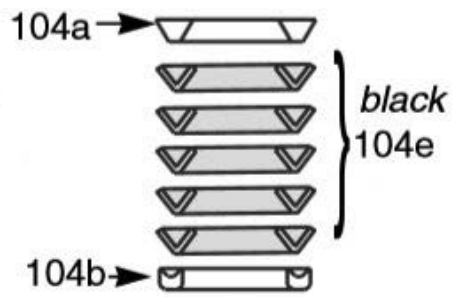
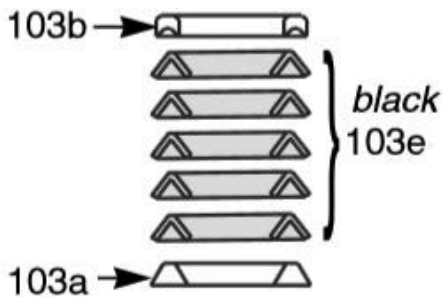

## PART NUMBERS AND SCHEMATICS GUIDE

### X-Tuff® Repair Kit for 220cc Lower Displacement Pump

Item#	Part#	Description
<b>Fig. 6</b>		
—	<b>20G262793</b>	<b>X-Tuff® Repair Kit</b> <i>(Includes Item #'s: 1 (Quantity of Two); 2 (Quantity of Two); 3 (Quantity of Four); 4 (Quantity of Six); 5 (Quantity of Four); 6 (Quantity of Two); 7, 8, 9, 10 (Quantity of Three); and 11)</i>
103	—	Throat Packings
103a	20G244883	Male Gland <i>(Quantity of Four)</i>
103b	20G244877	Female Gland <i>(Quantity of Four)</i>
103c	20G244859	V-Packing Carbon-Filled, PTFE/UHMWPE, Blue <i>(Quantity of 10)</i>
103d	20G244865	V-Packing, UHMWPE, Black <i>(Quantity of 10)</i>
104	—	Piston Packings
104a	20G244884	Male Gland <i>(Quantity of Four)</i>
104b	20G244878	Female Gland <i>(Quantity of Four)</i>
104c	20G244860	V-Packing Carbon-Filled, PTFE/UHMWPE, Blue <i>(Quantity of 10)</i>
104d	20G244866	V-Packing, UHMWPE, Black <i>(Quantity of 10)</i>
109	20G244893	PTFE O-Ring, Top Cylinder Medium <i>(Quantity of 10)</i>
112	20G244898	Ball Piston, 7/8 in (22 mm) <i>(Quantity of Three)</i>
116	20G253030	Ball Inlet, 1.5 in (38 mm) <i>(Quantity of Three)</i>
117	20G244856	Shim Inlet, Ball Guide <i>(Quantity of Nine)</i>
119	20G244999	Throat Seal Plug, 1-3/4 in <i>(Quantity of 10)</i>
—	20G247395	Throat Seal Plug, 2-1/2 in <i>(Quantity of 10)</i>
122	20G244895	Filter O-Ring, Thin, PTFE <i>(Quantity of 10)</i>
123	20G238436	Strainer, 30 mesh screen, 5.65 in <i>(Quantity of 25)</i>
—	20G224458	Strainer, 30 mesh, 5.65 in <i>(Quantity of Two)</i>
—	20G238438	Strainer, 60 mesh, 5.65 in <i>(Quantity of 25)</i>
—	20G224459	Strainer, 60 mesh, 5.65 in <i>(Quantity of Two)</i>
125	20G262484	Filter O-Ring, Medium, PTFE <i>(Quantity of 10)</i>
—	20G244896	Filter O-Ring For Series A Pumps <i>(Quantity of 10)</i>
127	20G244894	O-Ring, PTFE, Thin <i>(Quantity of 10)</i>
143	20G116802	Foot Valve Spring (20G262793 only)
159	20G262483	Top Cap O-Ring, PTFE <i>(Quantity of 10)</i>
—	20G244895	Top Cap O-Ring For Series A Pumps <i>(Quantity of 10)</i>
—	209V021	Operator's Manual— Graco® Xtreme® Pump Lowers

# PART NUMBERS AND SCHEMATICS GUIDE

Figure 6: X-Tuff® Repair Kit for 220cc Lower Displacement Pump

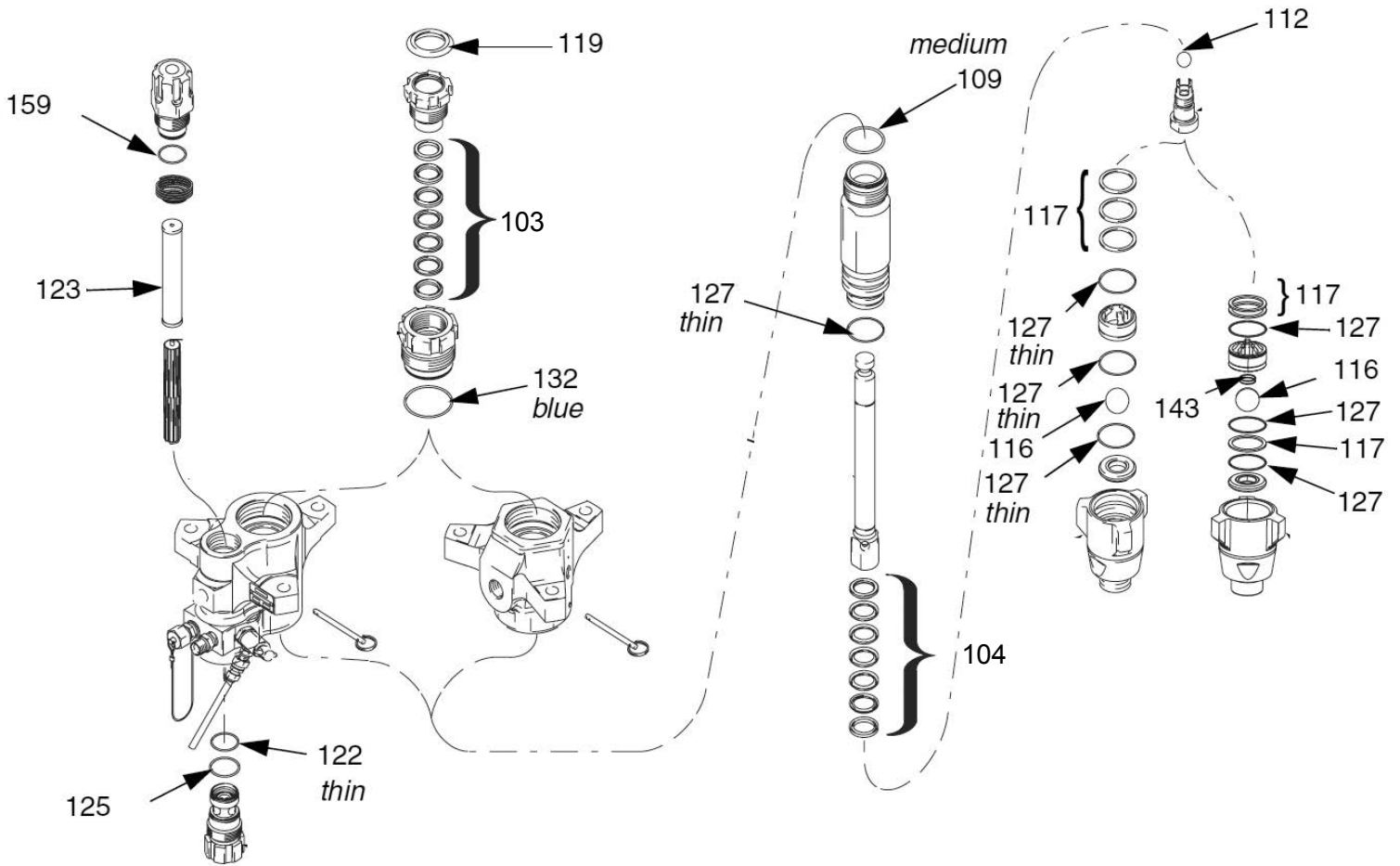

## X-Tuff® Seal Repair Kit 262793

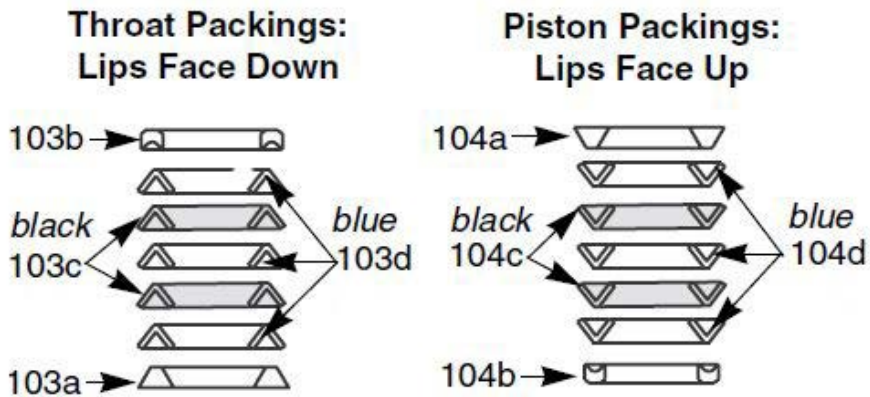

# PART NUMBERS AND SCHEMATICS GUIDE

**Figure 7: Filter Cap Series Key**

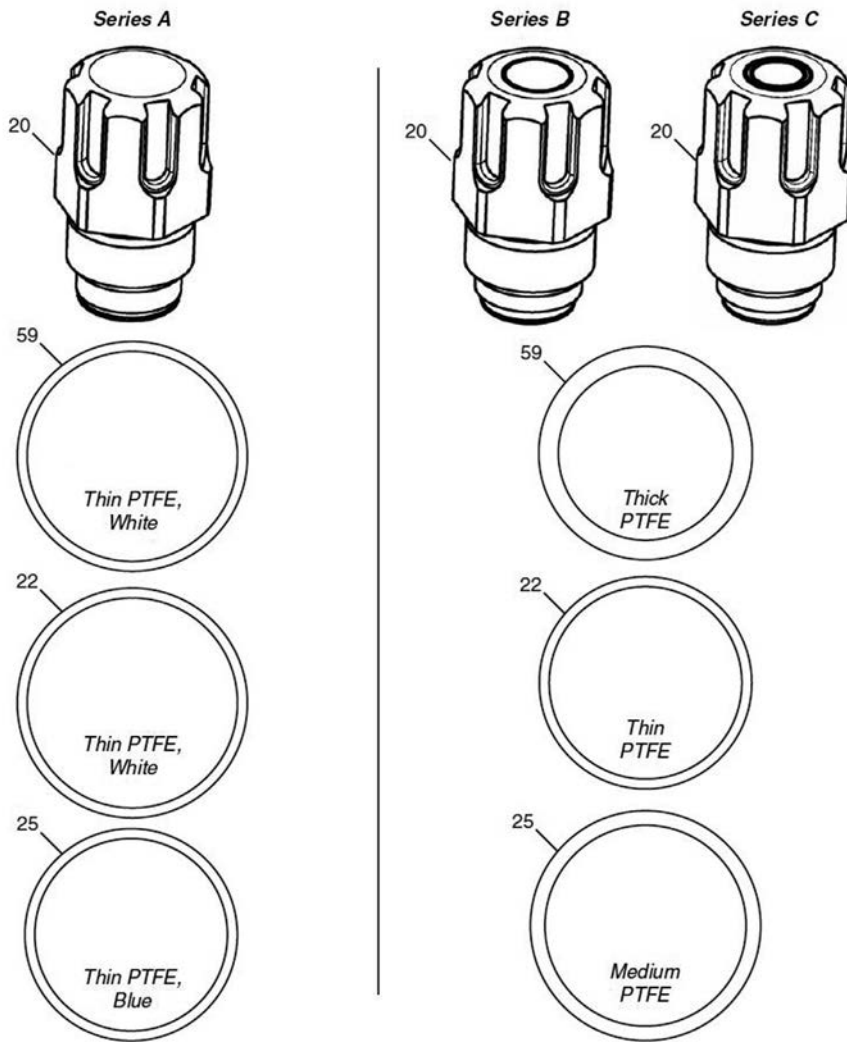





## Filter Cap Conversion Kits for Graco Xtreme Lowers

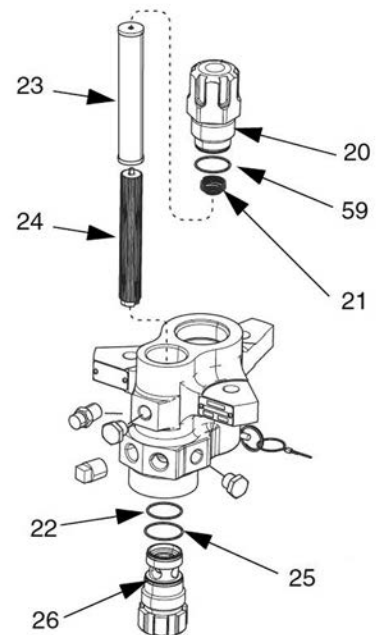

Converts Series A Lowers to Series B Lowers

Item#	Part#	Description
<b>Fig. 7</b>		
—	<b>20G24F975</b>	<b>Filter Cap Conversion Kit – Complete</b>
20	20G16M461	Tip Filter Cap
21	20G171941	Filter Spring
22	20G244895	O-Ring PTFE Thin ( <i>Quantity of 10</i> )
23a	20G224458	Strainer, 30 Mesh
23b	20G224459	Strainer, 60 Mesh
24	20G186075	Support
25	20G262484	O-Ring PTFE Medium ( <i>Quantity of 10</i> )
26	20G16M462	Filter Cap
59	20G262483	O-Ring PTFE Thick ( <i>Quantity of 10</i> )



## OPTIONAL ACCESSORIES

	Part Numbers	SUCTION TUBE AND ACCESSORIES	
		Description	
	20G197682	Suction Tube	
	20G247301	1" I.D. x 6' Suction Hose with Couplings	
	20G247302	1" I.D. x 10' Suction Hose with Couplings	
	20G245136	55 Gallon Suction Tube Extension Kit <i>Includes Suction Tube and Couplings</i>	
	20G181072	60 Mesh Strainer for 1" Suction Tube	

	Part Numbers	HIGH PRESSURE BALL VALVES		
		Thread Size	Seal Material	Working Pressure
	20G210657B	1/4" Male x 1/4" Male	Viton	5,000 psi
	20G210658B	3/8" Male x 3/8" Male	Viton	5,000 psi
	20G210659B	1/4" Male x 3/8" Male	Viton	5,000 psi
	20G214037	1/4" Male x 1/4" Male	Teflon	5,000 psi
	20G223959B	3/8" Male x 1/4" Male	Teflon	5,000 psi
	20G210658B	3/8" Male x 3/8" Male	Teflon	5,000 psi
	20DQVAE2AO14	1/4" Female x Female	Nitrile	7,000 psi
	20DQVAE2AO38	3/8" Female x Female	Nitrile	7,000 psi
	20DQVAE2AO12	1/2" Female x Female	Nitrile	7,000 psi

## OPTIONAL ACCESSORIES

### Graco® Xtreme® Airless Spray Pumps – Stainless Steel Hopper Kit

Item#	Part#	Description
<b>Fig. 8</b>		
—	<b>20G24X570</b>	<b>Xtreme® Sprayer Stainless Steel Hopper Kit – Heavy-Duty Cart</b>
—	<b>20G24Y402</b>	<b>Xtreme® Sprayer Stainless Steel Hopper Kit – Lightweight Cart</b>
1	20G17E114	Hopper
2	20G17C474	Bracket
3	20G17D554	Upper Bracket
4	20G126939	90° Elbow
5	20G128095	Cam/Groove
6	20G17C692	Cam/Groove Fitting, 1.5m, 1-1/2" NPT
7	20G128094	Bushing
8	20G112395	Flanges Cap Screw – HD ( <i>Quantity of Four</i> )
9	20G112958	Nut ( <i>Quantity of Four</i> )
10	20G17C453	Gasket
12	20G15M987	1/2" NPT (M) x 1/2" NPT (F) 60° Elbow
—	20G110110	6 ml Stainless Steel Pipe Sealant
—	20G16U537	Lid



## OPTIONAL ACCESSORIES

Figure 8: Graco® Xtreme® Airless Spray Pumps – Stainless Steel Hopper Kit

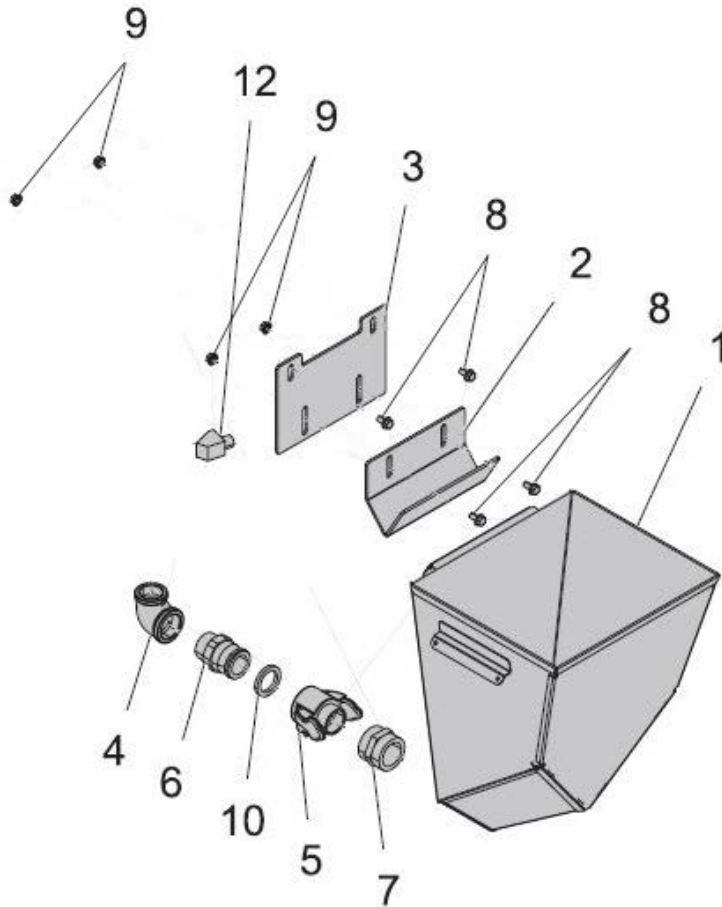





## GLOBAL HEADQUARTERS

- 3425 East Locust Street  
Davenport, IA 52803

ph: 800.BLAST.IT (800.252.7848)

ph: 563.324.2519

fax: 563.324.6258

## GULF STATES HEADQUARTERS

- 701 East Boulevard  
Deer Park, TX 77536

ph: 800.BLAST.IT (800.252.7848)

ph: 281.930.0905

fax: 281.542.0736

## REGIONAL BRANCH OFFICES

- **Iowa**  
Davenport
- **Louisiana**  
Gonzales  
Lafayette
- **Ohio**  
Youngstown
- **Texas**  
Beaumont  
Corpus Christi  
Deer Park



ABRASIVES

BLASTING

COATING

DUST COLLECTORS

ENGINEERED SYSTEMS

RENTAL

SAFETY

SERVICE & REPAIR

VACUUMS

## 40+ NATIONWIDE SHIPPING LOCATIONS



★ Marco Regional Branch Offices  
and Shipping Locations

● Direct Shipping Locations

## CONTACT MARCO

**800.BLAST.IT**  
**(800.252.7848)**

**563.324.2519**

**FAX: 563.324.6258**

**WWW.MARCO.US**

**SALES@MARCO.US**