

XP Proportioners

3A0420T

EN

Mechanically linked fixed ratio plural-component system used for proportioning, mixing, and spraying two component coatings. For professional use only.



Important Safety Instructions

Read all warnings and instructions in this manual. Save these instructions.

See page 11 for maximum working pressure and model information.

XP70 system shown with hoppers and optional solvent flush pump and heaters.

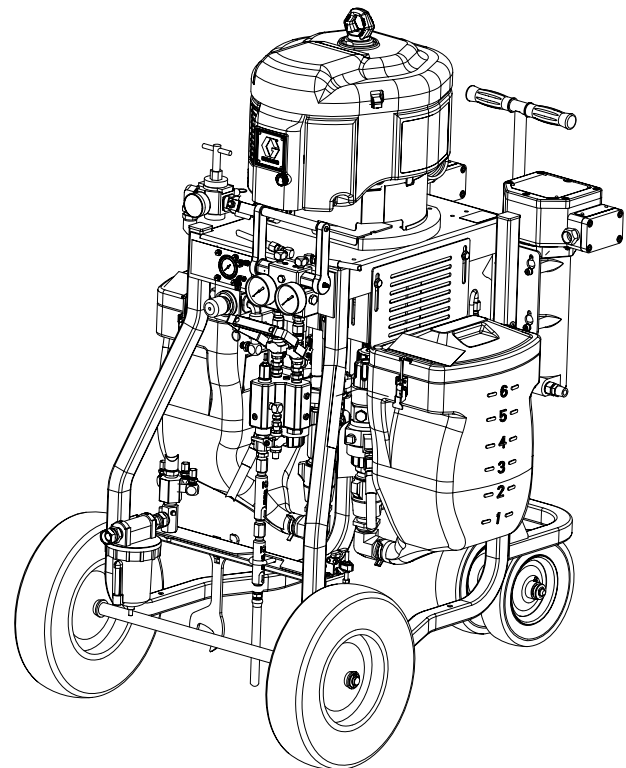

r_571100_3A0420A_1a-2



Contents

Related Manuals	3	Shutdown	30
Warnings	4	Park	30
Important Two-Component Material Information .	7	System Verification	31
Isocyanate Conditions	7	Maintenance	32
Material Self-ignition	7	Hose Electrical Resistance	32
Keep Components A and B Separate	7	Filters	32
Moisture Sensitivity of Isocyanates	7	Seals	32
Foam Resins with 245 fa Blowing Agents	7	Cleaning Procedure	32
Changing Materials	8	Recommended Spare Parts	32
A and B Component Designations	8	Change the Mix Ratio	32
Overview	9	Troubleshooting	33
Usage	9	Pump Troubleshooting	34
Over Pressure Protection	9	Repair	35
Initial System Setup	10	Pump Assembly	35
Models	11	Air Controls	36
Cart-Mounted Systems	11	Mix Manifold Assembly	38
Bare Proportioning Pump Packages	13	Fluid Circulation Manifold with Over Pressure Relief Valves	38
Component Identification	14	Hoppers	40
Fluid Control Assembly	15	Optional Solvent Pump	40
Main Air Controls	15	Optional Fluid Heaters	41
45:1 Solvent Flush Pump Kit 262393 (optional)	16	Parts	42
Air Line	17	Cart-Mounted System	42
Fluid Line Accessories	17	Bare Proportioning Pump Package	50
Flush Before Using Equipment	17	Air Controls, 258983	52
Setup	18	Fluid Circulation Manifold with Over Pressure Relief Valve	53
Location	18	Recommended Spare Parts	54
Grounding	18	Accessories and Kits	55
Wire Systems with Explosion-Proof Heaters . . .	19	Acceptable For Use in Explosive Atmospheres .	55
Motor Position	20	Not Approved For Explosive Atmospheres	56
Connect Air Supply	21	Technical Data	57
Connect Static Mixers, Gun, and Hoses	21	Dimensions	58
Connect Fluid Hose Bundles (Remote Mix Manifold Only)	21	Bare Proportioner Mounting Hole Dimensions .	60
Pressure Relief Procedure	22	Wall Mount Bracket 262812 Dimensions	61
Prime Empty System	23	Floor Stand 24M281 Dimensions	62
Prime A and B Fluids	23	Hydraulic Unit Dimensions	62
Prime Solvent Flush Pump	24	Graco Standard Warranty	64
Recirculate Prior to Spraying or Re-Prime After a Pump Runs Dry	25		
Spray	26		
B Side Mix Manifold Restriction	27		
Flush Mixed Material	28		
Flush Mix Manifold, Hose, and Spray Gun	28		
Empty and Flush Entire System (new system or end of job)	29		





Related Manuals

Manuals are available at www.graco.com. Component manuals in English:

Manual	Description
312145	XTR™ 5 and XTR™ 7 Spray Guns Instructions-Parts
Pump Package Components	
307158	Viscount® II Hydraulic Motor Instructions-Parts
311238	NXT® Air Motor Instructions-Parts
311762	Xtreme® Displacement Pumps Instructions-Parts
Hopper Kits	
312747	20 Gallon Double Wall Hopper Kit Instructions-Parts
406860	7 Gallon Hopper Installation Kit Instructions-Parts
Heating	
309524	Viscon® HP Heater Instructions-Parts
309525	Heated Hose Kit, Instructions-Parts
313259	Hopper or Hose Heat Circulation Kit
406861	Viscon HP Heater Adapter Kit, Instructions-Parts
Solvent Flush	
310863	Feed and Solvent Flush Kits
312794	Merkur® Pump Assembly Instructions-Parts
Accessories and Kits	
309852	Polyurethane Circulation and Return Tube Kits, Instructions-Parts
311486	DataTrak™ Conversion Kit, Instructions-Parts
312769	Feed Pump and Agitator Kits Instructions-Parts
339361	High Pressure Hose and Accessories Brochure
3A0421	Ratio Check Kit, Instructions-Parts
3A0590	Mix Manifold, Quickset Mix Manifold Instructions-Parts
3A2573	Gun Splitter Valve with Independent Flush, Instructions-Parts
406739	Desiccant Kit Instructions-Parts

Warnings

The following warnings are for the setup, use, grounding, maintenance, and repair of this equipment. The exclamation point symbol alerts you to a general warning and the hazard symbols refer to procedure-specific risks. When these symbols appear in the body of this manual, refer back to these Warnings. Product-specific hazard symbols and warnings not covered in this section may appear throughout the body of this manual where applicable.

 WARNING	
	<p>FIRE AND EXPLOSION HAZARD</p> <p>Flammable fumes, such as solvent and paint fumes, in work area can ignite or explode. To help prevent fire and explosion:</p> <ul style="list-style-type: none"> • Use equipment only in well ventilated area. • Eliminate all ignition sources; such as pilot lights, cigarettes, portable electric lamps, and plastic drop cloths (potential static arc). • Keep work area free of debris, including solvent, rags and gasoline. • Do not plug or unplug power cords, or turn power or light switches on or off when flammable fumes are present. • Ground all equipment in the work area. See Grounding instructions. • Use only grounded hoses. • Hold gun firmly to side of grounded pail when triggering into pail. • If there is static sparking or you feel a shock, stop operation immediately. Do not use equipment until you identify and correct the problem. • Keep a working fire extinguisher in the work area.
	<p>SPECIAL CONDITIONS FOR SAFE USE</p> <ul style="list-style-type: none"> • To prevent the risk of electrostatic sparking, the equipment's non-metallic parts must be cleaned with only a damp cloth. • Refer to the Viscon HP Heater manual for special conditions for safe use.
	<p>ELECTRIC SHOCK HAZARD</p> <p>This equipment must be grounded. Improper grounding, setup, or usage of the system can cause electric shock.</p> <ul style="list-style-type: none"> • Turn off and disconnect power at main switch before disconnecting any cables and before servicing equipment. • Connect only to grounded power source. • All electrical wiring must be done by a qualified electrician and comply with all local codes and regulations.

! WARNING



SKIN INJECTION HAZARD

High-pressure fluid from gun, hose leaks, or ruptured components will pierce skin. This may look like just a cut, but it is a serious injury that can result in amputation. **Get immediate surgical treatment.**

- Do not spray without tip guard and trigger guard installed.
- Engage trigger lock when not spraying.
- Do not point gun at anyone or at any part of the body.
- Do not put your hand over the spray tip.
- Do not stop or deflect leaks with your hand, body, glove, or rag.
- Follow the **Pressure Relief Procedure** when you stop spraying and before cleaning, checking, or servicing equipment.
- Tighten all fluid connections before operating the equipment.
- Check hoses and couplings daily. Replace worn or damaged parts immediately.



EQUIPMENT MISUSE HAZARD

Misuse can cause death or serious injury.

- Do not operate the unit when fatigued or under the influence of drugs or alcohol.
- Do not exceed the maximum working pressure or temperature rating of the lowest rated system component. See **Technical Data** in all equipment manuals.
- Use fluids and solvents that are compatible with equipment wetted parts. See **Technical Data** in all equipment manuals. Read fluid and solvent manufacturer's warnings. For complete information about your material, request MSDS from distributor or retailer.
- Do not leave the work area while equipment is energized or under pressure. Turn off all equipment and follow the **Pressure Relief Procedure** when equipment is not in use.
- Check equipment daily. Repair or replace worn or damaged parts immediately with genuine manufacturer's replacement parts only.
- Do not alter or modify equipment.
- Use equipment only for its intended purpose. Call your distributor for information.
- Route hoses and cables away from traffic areas, sharp edges, moving parts, and hot surfaces.
- Do not kink or over bend hoses or use hoses to pull equipment.
- Keep children and animals away from work area.
- Comply with all applicable safety regulations.





MOVING PARTS HAZARD

Moving parts can pinch, cut or amputate fingers and other body parts.

- Keep clear of moving parts.
- Do not operate equipment with protective guards or covers removed.
- Pressurized equipment can start without warning. Before checking, moving, or servicing equipment, follow the **Pressure Relief Procedure** and disconnect all power sources.

⚠️ WARNING

	<p>TOXIC FLUID OR FUMES HAZARD</p> <p>Toxic fluids or fumes can cause serious injury or death if splashed in the eyes or on skin, inhaled, or swallowed.</p> <ul style="list-style-type: none"> • Read MSDSs to know the specific hazards of the fluids you are using. • Store hazardous fluid in approved containers, and dispose of it according to applicable guidelines. • Always wear chemically impermeable gloves when spraying, dispensing, or cleaning equipment.
	<p>PERSONAL PROTECTIVE EQUIPMENT</p> <p>You must wear appropriate protective equipment when operating, servicing, or when in the operating area of the equipment to help protect you from serious injury, including eye injury, hearing loss, inhalation of toxic fumes, and burns. This equipment includes but is not limited to:</p> <ul style="list-style-type: none"> • Protective eyewear, and hearing protection. • Respirators, protective clothing, and gloves as recommended by the fluid and solvent manufacturer.
	<p>BURN HAZARD</p> <p>Equipment surfaces and fluid that's heated can become very hot during operation. To avoid severe burns:</p> <ul style="list-style-type: none"> • Do not touch hot fluid or equipment.

Important Two-Component Material Information

Isocyanate Conditions



Spraying or dispensing materials containing isocyanates creates potentially harmful mists, vapors, and atomized particulates.

Read material manufacturer's warnings and material MSDS to know specific hazards and precautions related to isocyanates.

Prevent inhalation of isocyanate mists, vapors, and atomized particulates by providing sufficient ventilation in the work area. If sufficient ventilation is not available, a supplied-air respirator is required for everyone in the work area.

To prevent contact with isocyanates, appropriate personal protective equipment, including chemically impermeable gloves, boots, aprons, and goggles, is also required for everyone in the work area.

Material Self-ignition

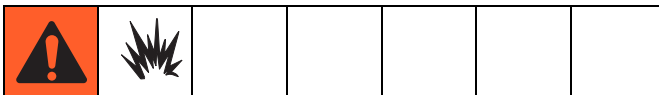

Some materials may become self-igniting if applied too thick. Read material manufacturer's warnings and material MSDS.

Keep Components A and B Separate



Cross-contamination can result in cured material in fluid lines which could cause serious injury or damage equipment. To prevent cross-contamination of the equipment's wetted parts, **never** interchange component A (isocyanate) and component B (resin) parts.

Moisture Sensitivity of Isocyanates

Isocyanates (ISO) are catalysts used in two component foam and polyurea coatings. ISO will react with moisture (such as humidity) to form small, hard, abrasive crystals, which become suspended in the fluid. Eventually a film will form on the surface and the ISO will begin to gel, increasing in viscosity. If used, this partially cured ISO will reduce performance and the life of all wetted parts.

NOTE: The amount of film formation and rate of crystallization varies depending on the blend of ISO, the humidity, and the temperature.

To prevent exposing ISO to moisture:

- Always use a sealed container with a desiccant dryer in the vent, or a nitrogen atmosphere. **Never** store ISO in an open container.
- Keep the ISO pump wetcup or reservoir (if installed) filled with Graco Throat Seal Liquid (TSL™), Part 206995. The lubricant creates a barrier between the ISO and the atmosphere.
- Use moisture-proof hoses specifically designed for ISO.
- Never use reclaimed solvents, which may contain moisture. Always keep solvent containers closed when not in use.
- Never use solvent on one side if it has been contaminated from the other side.
- Always lubricate threaded parts with TSL or grease when reassembling.

Foam Resins with 245 fa Blowing Agents

Some foam blowing agents will froth at temperatures above 90°F (33°C) when not under pressure, especially if agitated. To reduce frothing, minimize preheating in a circulation system.

Changing Materials

- Changing material types used in your system requires special attention to avoid equipment damage and downtime.
- Always clean the fluid inlet strainers after flushing.
- When changing between epoxies and urethanes or polyureas, disassemble and clean all fluid components and changes hose sets.
- Check with your material manufacturer for chemical compatibility.
- Most materials use ISO on the A side, but some use ISO on the B side.
- Epoxies often have amines on the B (hardener) side. Polyureas often have amines on the B (resin) side.

A and B Component Designations

Material suppliers and markets refer to plural component materials differently. The table below summarizes the different designations for the components used in various machines.

Market	Equipment	Designations	Machine Left Side	Machine Right Side
Foam and Polyurea, and Urethane Pour	All Reactors, HFR™, and VRM™	Letter	A	B
		Color	Red	Blue
		Component Names	ISO, Hardener, Catalyst	Polyol, Resin, Base
		Major or Minor Component (when not 1:1 mix)	Low Volume Side	High Volume Side
Epoxy and Urethane Protective Coatings	Hydra-Cat®, Xtreme-Mix™, XM™, and XP	Letter	A	B
		Color	Blue	Green
		Component Names	Resin, Base	Hardener, Catalyst
		Major or Minor Component (when not 1:1 mix)	High Volume Side	Low Volume Side
Epoxy, Silicone, Urethanes, and other materials	PR70™ and PR	Letter	A	B
		Color	Red	Blue
		Component Names	Polyol, Resin, Base	ISO, Hardener, Catalyst
		Major or Minor Component (when not 1:1 mix)	High Volume Side	Low Volume Side

Overview

Usage

The XP is a mechanically linked fixed ratio system that can mix and spray most two-component epoxy and urethane protective coatings. When using quick-setting material (less than 10 minute pot life) a remote mix manifold must be used or materials must mix at the gun. Quickset manifold 24M398 is recommended for quick-setting material.

The two pumps are carbide seat severe duty positive displacement pumps that displace fluid on both strokes.

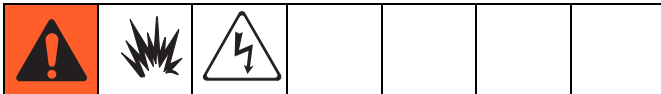

The XP systems are not approved for use in hazardous locations unless the base model, all accessories, all kits, and all wiring meet local, state, and national codes. See **Important Two-Component Material Information**, page 7, to determine the appropriate location for your particular XP model.

Over Pressure Protection



Mechanically linked pumps can create excessive fluid pressure if the full motor force is applied to only one of the fluid pumps.

- *Cart-Mounted Systems Only:* Maximum air pressure set point blow off valves are provided to limit maximum fluid pressure. Do not remove these valves.
- Color coded automatic over pressure relief valves are used on cart-mounted systems to dump excess fluid pressure back to the supply. Never plug these return hoses. See **Fluid Circulation Manifold with Over Pressure Relief Valves** on page 38.
- When using an XP bare pump package to build a system, use the over pressure relief valves referenced above.
- Never install individual shut off valves on the “A” and “B” lines. On cart-mounted systems, common handles link the fluid control valves.
- On models other than 1:1 mix ratio, a rupture disc is provided on the small side fluid pump (pumps 72cc and smaller) as a back-up to the over pressure relief valve. If the rupture disc ever opens, do not operate the machine until the over pressure valve and the rupture disc have been replaced.
- If changing pump lowers or motor on your system, use the correct over pressure relief valves from the chart on page 39.



Initial System Setup

1. Check the shipment for accuracy. Ensure you have received everything you ordered. See **Component Identification**, page 14.
2. Check for loose fittings and fasteners.
3. Install optional solvent flush pump kit 262393, if ordered. See manual 310863 for instructions.
4. Mount and connect optional heaters, if ordered. See the heater adapter kit manual 406861 for instructions and the heater manual 309524.
5. Install desiccant kits if using polyurethane isocyanates in hoppers. See manual 406739 for instructions.
6. Install circulation and return tube kits if you are feeding material from drums or remote hoppers. See manual 309852 if you are feeding urethane material.
7. Install hopper or hose heat circulation kit 24M224, if ordered. See 313259 for instructions.

NOTE: Supply return lines must be used.

8. Connect the feed pumps, fluid strainers, and air hoses as necessary. If your system does not use hoppers, then see manual 312769.
9. Connect the air supply line. See **Connect Air Supply**, page 21.
10. Connect the fluid hose assembly, including the static mixers, whip hose and gun. See **Pressure Relief Procedure**, page 22.
11. Flush test oil from system as needed. See **Empty and Flush Entire System (new system or end of job)**, page 29.

Models

						
The XP systems are approved for use in hazardous locations only if the base model, all accessories, all kits, and all wiring meet local, state, and national codes.						

Cart-Mounted Systems

NOTE: All cart-mounted systems listed are Ex rated:  II 2 G c IIA T2

See **Accessories and Kits** on page 55 for a list of all optional accessories.

NOTE: The “Standard” mix manifold selection means the mix manifold is mounted on the cart and comes with mixers, 25 ft of 3/8 in. mix hose, and 10 ft of 1/4 in. whip hose. The “Quickset” mix manifold selection means the manifold has dual flush valves, is mounted on a remote carriage, and comes with mixers and 10 ft of 1/4 in. whip hose. When ordering the Quickset configuration, A and B hoses from the sprayer to the mix manifold must be ordered separately.

Type	Model	Pump Package	Volume Mix Ratio	7 Gallon Hoppers	Mix Manifold	Hose	Gun	Max Fluid Working Pressure psi (MPa, bar)	Max Air Pressure psi (MPa, bar)	Pressure Ratio
XP35 with NXT 3400 Air Motor	281000	---	---					---	---	---
	281101	281100	1.0:1		Standard	35 ft (10.7 m)	XTR5	3500 (24, 241)	95 (0.65, 6.5)	38:1
	281102			✓						
	281105				---	---	---			
	281106			✓						
	281201	281200	2.0:1		Standard	35 ft (10.7 m)	XTR5	3500 (24, 241)	85 (0.59, 5.9)	40:1
	281202			✓						
	281205				---	---	---			
	281206			✓						
	262804	262803	2.5:1		Standard	35 ft (10.7 m)	XTR5	3500 (24, 241)	90 (0.62, 6.2)	34:1
	281252			✓						
	281255				---	---	---			
	281256			✓						
	281301	281300	3.0:1		Standard	35 ft (10.7 m)	XTR5	3500 (24, 241)	100 (0.7, 7)	36:1
	281302			✓						
	281305				---	---	---			
281306	✓									
281401	281400	4.0:1		Standard	35 ft (10.7 m)	XTR5	3500 (24, 241)	95 (0.65, 6.5)	38:1	
281402			✓							
281405				---	---	---				
281406			✓							

Models

Type	Model	Pump Package	Volume Mix Ratio	7 Gallon Hoppers	Mix Manifold	Hose	Gun	Max Fluid Working Pressure psi (MPa, bar)	Max Air Pressure psi (MPa, bar)	Pressure Ratio
XP50 with 6500 Air Motor	282000	---	---		Standard	35 ft (10.7 m)	XTR5	---	---	---
	282101	282100	1.0:1					---	---	---
	282102			✓						
	282105									
	282106			✓						
	282151	282150	1.5:1		Standard	35 ft (10.7 m)	XTR5	5000 (34, 344)	90 (0.62, 6.2)	55:1
	282152			✓						
	282155									
	282156			✓						
	282201	282200	2.0:1		Standard	35 ft (10.7 m)	XTR5	4500 (31, 310)	100 (0.7, 7)	48:1
	282202			✓						
	282205									
	282206			✓						
	282251	282250	2.5:1		Standard	35 ft (10.7 m)	XTR5	5000 (34, 344)	95 (0.65, 6.5)	52:1
	282252			✓						
	282255									
	282256			✓						
	282301	282300	3.0:1		Standard	35 ft (10.7 m)	XTR5	4500 (31, 310)	100 (0.7, 7)	45:1
	282302			✓						
	282305									
	282306			✓						
	282331	282330	3.3:1		Standard	35 ft (10.7 m)	XTR5	5000 (34, 344)	90 (0.62, 6.2)	56:1
	282332			✓						
	282401									
282402	✓									
282405	282400	4.0:1		---	---	---	4800 (33, 331)	100 (0.7, 7)	48:1	
282406			✓							
283101	282100	1.0:1		Quickset	10 ft (3.0 m)	FlexPlus	4500 (31, 310)	100 (0.7, 7)	45:1	
283102			✓							
283201	282200	2.0:1								
283202			✓							
283301	282300	3.0:1								
283302			✓							
283401	282400	4.0:1								
283402			✓							
XP70 with NXT 6500 Air Motor	571000	---	---		Standard	35 ft (10.7 m)	XTR7	---	---	---
	571101	571100	1.0:1					7250 (50, 500)	95 (0.65, 6.5)	76:1
	571102			✓						
	571151	571150	1.5:1							
	571152			✓						
	571201	571200	2.0:1							
	571202			✓						
	571251	571250	2.5:1							
	571252			✓						
	571301	571300	3.0:1							
	571302			✓						
	571401	571400	4.0:1							
571402	✓									

Bare Proportioning Pump Packages

Packages include motor, pump lowers, and all connection hardware.

NOTE: All pump packages are Ex rated except for the XP-h pump packages (284xxx):



Building systems with bare proportioning pump packages:

- **Over Pressure Protection** must be used, see page 9. See chart on page 39 to identify the over pressure relief valves to use with your system.
- All components must meet or exceed maximum working pressures.

Hydraulically powered pump packages (XP-h) are not available as complete systems. Refer to manual 307158 for hydraulic application information.

Pump sizes are marked on the pump cylinder; sizes are nominal. See technical data in manual 311762 for actual displacement.

Type	Pump Package	A Side Pump	B Side Pump	Volume Mix Ratio	Combined Fluid Output cc/cycle	Pressure Ratio	Fluid Flow at 40 cpm gpm (lpm)	Maximum Fluid Working Pressure psi (MPa, bar)	Maximum Air/ Hydraulic Oil Working Pressure psi (MPa, bar)	Ex Rated	Over Pressure Relief Valve To Use	
XP35 with NXT 3400 Air Motor	281100	L090C0	L090C0	1.0:1	180	38:1	1.9 (7.2)	3500 (24, 241)	95 (0.65, 6.5)	✓	Purple	
	281200	L115C0	L058C0	2.0:1	173	40:1	1.8 (6.8)	3500 (24, 241)	85 (0.59, 5.9)			
	262803	L14AC0	L058C0	2.5:1	202	34:1	2.1 (7.9)	3500 (24, 241)	100 (0.7, 7)			
	281300	L14AC0	L048C0	3.0:1	192	36:1	2.0 (7.6)	3400 (23, 234)	95 (0.65, 6.5)			
	281400	L14AC0	L036C0	4.0:1	180	38:1	1.9 (7.2)	3500 (24, 241)	90 (0.62, 6.2)			
XP50 with NXT 6500 Air Motor	282100	L14AC0	L14AC0	1.0:1	288	45:1	3.1 (11.7)	4500 (31, 310)	100 (0.7, 7)		✓	Gold
	282150	L14AC0	L097C0	1.5:1	240	55:1	2.6 (9.8)	5000 (34, 345)	90 (0.62, 6.2)			
	282200	L18AC0	L090C0	2.0:1	270	48:1	2.9 (11.0)	4800 (33, 331)	100 (0.7, 7)			
	282250	L18AC0	L072C0	2.5:1	252	52:1	2.7 (10.2)	5000 (34, 345)	95 (0.65, 6.5)			
	282300	L22AC0	L072C0	3.0:1	288	45:1	3.1 (11.7)	4500 (31, 310)	100 (0.7, 7)			
	282330	L18AC0	L054C0	3.3:1	234	56:1	2.5 (9.5)	5000 (34, 345)	95 (0.65, 6.5)			
XP70 with NXT 6500 Air Motor	282400	L22AC0	L054C0	4.0:1	270	48:1	2.9 (11.0)	4800 (33, 331)	100 (0.7, 7)		✓	Silver
	571100	L090C0	L090C0	1.0:1	180	72:1	1.9 (7.2)	7250 (50, 500)	100 (0.7, 7)			
	571150	L085C0	L058C0	1.5:1	144	91:1	1.5 (5.6)	7250 (50, 500)	80 (0.55, 5.5)			
	571200	L115C0	L058C0	2.0:1	174	76:1	1.8 (6.8)	7250 (50, 500)	95 (0.65, 6.5)			
	571250	L14AC0	L058C0	2.5:1	203	65:1	2.1 (7.9)	6500 (45, 448)	100 (0.7, 7)			
	571300	L14AC0	L048C0	3.0:1	193	68:1	2.0 (7.5)	6500 (45, 448)	100 (0.7, 7)			
XP-h with Viscount II Hydraulic Motor	284101	L22AC0	L22AC0	1.0:1	435	1.75:1	4.6 (17.4)	3150 (22, 217)	1800 (12, 124)	✓	Purple	
	284102	L14AC0	L14AC0			2.63:1	3.1 (11.7)	4700 (32, 324)	1800 (12, 124)		Gold	
	284103	L090C0	L090C0			4.21:1	1.9 (7.2)	7150 (49, 493)	1700 (12, 117)		Silver	
	284201	L29AC0	L14AC0	2.0:1	435	1.75:1	4.6 (17.4)	3150 (22, 217)	1800 (12, 124)		Purple	
	284202	L18AC0	L090C0			2.81:1	2.9 (11.0)	5050 (35, 348)	1800 (12, 124)		Gold	
	284203	L115C0	L058C0			4.39:1	1.8 (6.8)	7200 (50, 496)	1650 (11, 114)		Silver	
	284251	L29AC0	L115C0	2.5:1	407	1.88:1	4.3 (16.3)	3400 (23, 234)	1800 (12, 124)		Purple	
	284252	L18AC0	L072C0			3.02:1	2.7 (10.2)	5000 (34, 345)	1650 (11, 114)		Gold	
	284253	L14AC0	L058C0			3.77:1	2.1 (7.9)	6800 (47, 469)	1800 (12, 124)		Silver	
	284301	L29AC0	L097C0	3.0:1	388	1.97:1	4.1 (15.5)	3500 (24, 241)	1800 (12, 124)		Purple	
	284302	L22AC0	L072C0			2.63:1	3.1 (11.7)	4700 (32, 324)	1800 (12, 124)		Gold	
	284303	L14AC0	L048C0			3.95:1	2.0 (7.6)	7100 (49, 490)	1800 (12, 124)		Silver	
	284401	L29AC0	L072C0	4.0:1	360	2.10:1	3.8 (14.4)	3800 (26, 262)	1800 (12, 124)		Purple	
	284402	L22AC0	L054C0			2.80:1	2.9 (11.0)	5000 (34, 345)	1800 (12, 124)		Gold	
	284403	L14AC0	L036C0			4.21:1	1.9 (7.2)	7150 (49, 493)	1700 (12, 117)		Silver	

Component Identification

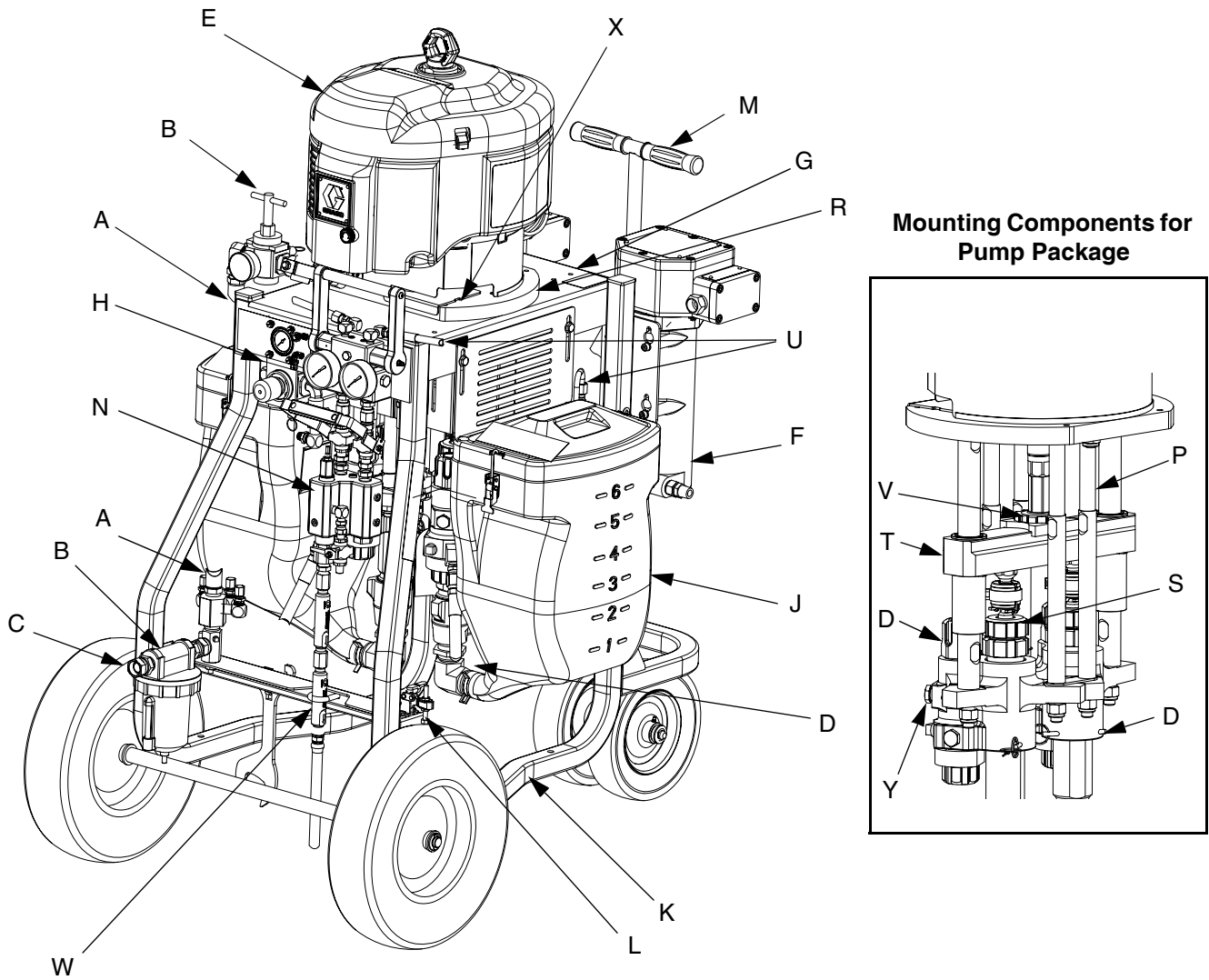

r_571101_3a0420a_1a-2

FIG. 1: XP70 system with optional accessories

Key:

- | | | | |
|---|---|---|--|
| A | Air Supply Hose for Motor | N | Fluid Control Assembly; <i>see page 15</i> |
| B | Main Air Controls; <i>see page 15</i> | P | Tie Rods |
| C | Air Inlet - 3/4 npsm(f) | R | Motor Adapter Plate |
| D | High Pressure Fluid Pump | S | Adjustable Packing Nuts with Wet Cups |
| E | Motor | T | Yoke With Rod Bearings |
| F | Fluid Heater (optional) | U | Recirculation Lines |
| G | Solvent Flush Pump (optional); <i>see page 16</i> | V | Yoke Position Nut |
| H | Solvent Flush Pump Air Controls; <i>see page 16</i> | W | Static Mixer Tubes with Replacement Plastic Elements |
| J | 7 Gallon Hoppers (optional) | X | Motor Position Indicator Lines; <i>see Motor Position on page 20</i> |
| K | Cart | Y | Over Pressure Rupture Disc; |
| L | Brake | | <i>only 38cc, 48cc, 54cc, 58cc, and 72cc pumps</i> |
| M | Handle (lift to release) | | |

Fluid Control Assembly

Standard Mix Manifold shown

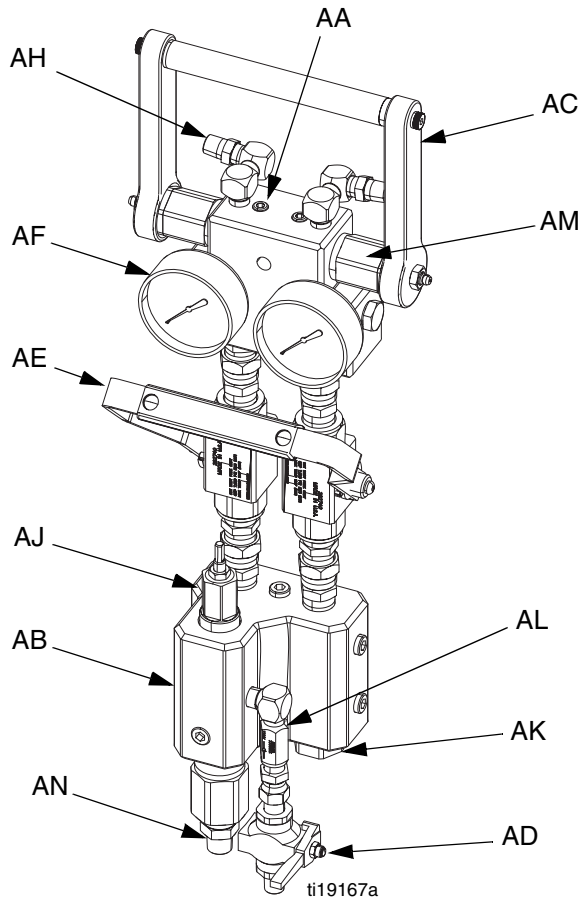

Key:

- AA Fluid Manifold
- AB Mix Manifold
- AC Circulation Handle
- AD Solvent Flush Valve
- AE Dual Shutoff Handle
- AF Fluid Pressure Gauges
- AG Fluid Supply Inlet (Behind Fluid Manifold)
- AH Fluid Circulation Fittings
- AJ B Component Adjustable Fluid Restrictor; see page 27
- AK A and B Mix Manifold Check Valves
- AL Solvent Inlet Check Valve
- AM Automatic, Spring Loaded, Color-Coded Over Pressure Relief Valves; with grease fittings; see page 39
- AN A and B Combined Outlet; 3/8 npt(m)

FIG. 2

Main Air Controls

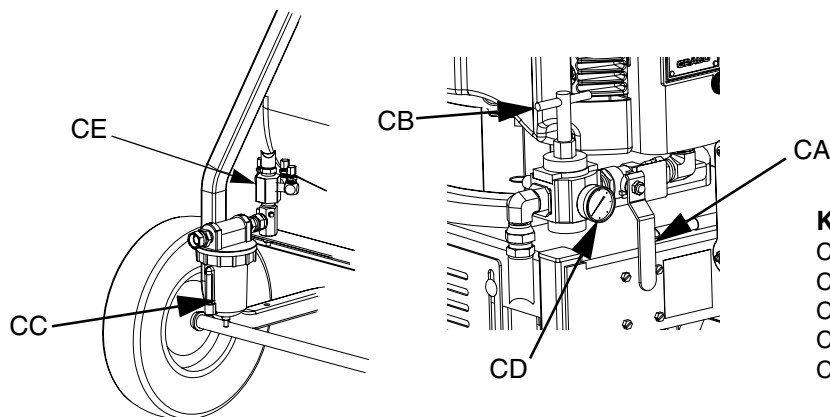

Key:

- CA Main Motor Shutoff Valve (Relieving)
- CB Main Motor Air Pressure Regulator
- CC Air Filter with Auto Drain
- CD Main Motor Air Pressure Gauge
- CE Filtered Air Distribution Manifold

FIG. 3

45:1 Solvent Flush Pump Kit 262393 (optional)

Pump

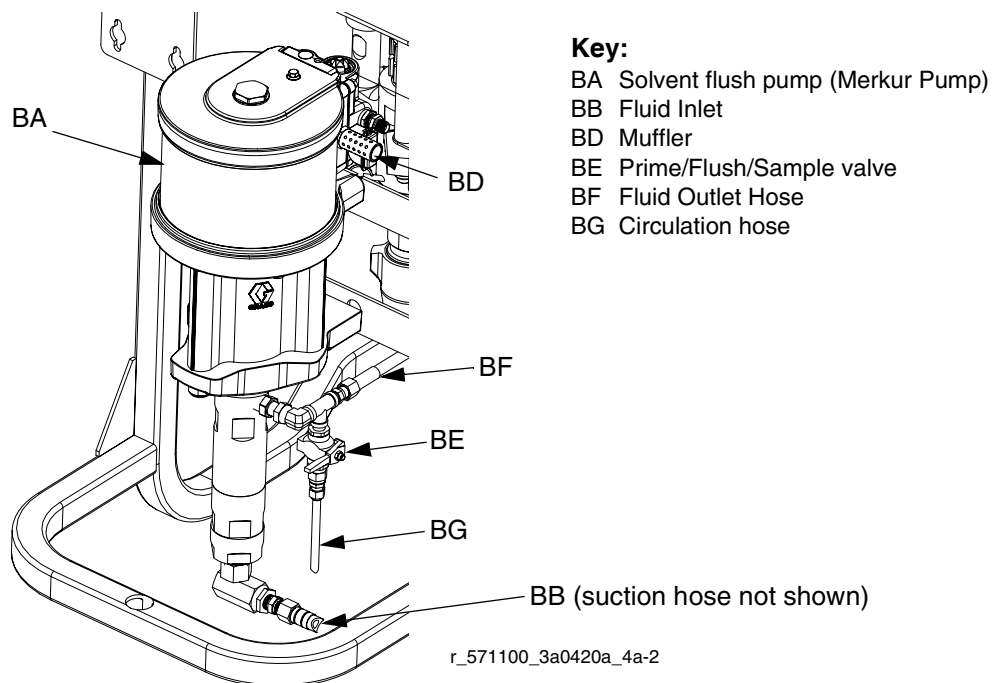

FIG. 4

Air Controls

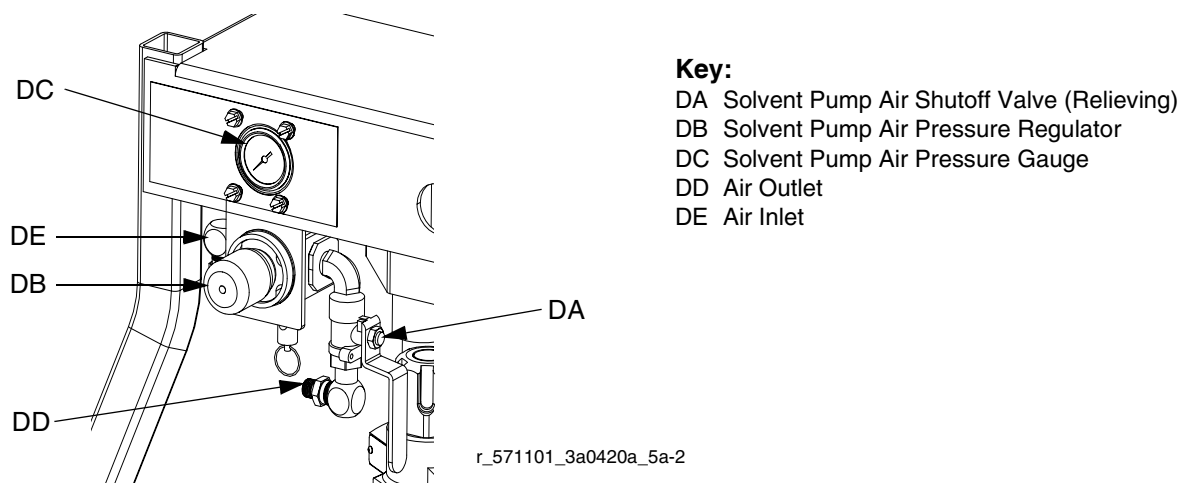

FIG. 5

Air Line

- **Bleed-type master air valve (CA):** Required in your system to relieve air trapped between it and the air motor when the valve is closed. Be sure the valve is easily accessible from the pump and located downstream from the air regulator.



Trapped air can cause the pump to cycle unexpectedly, which could result in serious injury from splashing or moving parts.

- **Pump air regulator (CB):** Controls pump speed and outlet pressure.
- **Air line filter (C):** 40 micron filter removes harmful dirt and moisture from compressed air supply. Accumulated water is automatically drained from the filter.

Fluid Line Accessories

- **Fluid Manifold (AA):** Controls circulation and pump priming.
- **Mix Manifold (AB):** Combines A and B fluid into one fluid line.
- **Circulation Handle (AC):** Directs fluid flow for circulation or mixing. Move to open position to relieve fluid pressure, prime pumps, and circulate material in hoppers. Move to closed position to spray mixed material.
- **Dual Shutoff Handle (AE):** Controls A and B fluid flow for mixing and dispensing. Close before flushing.
- **Solvent Flush Valve (AD):** Controls solvent flow to the mix manifold, hose, and spray gun.
- **Static mixer/gun hose kit:** Thoroughly mixes the two fluids and delivers the mixed fluid to the spray gun. Includes static mixer and hoses to the spray gun.

Optional Accessories



- **Optional Fluid Heaters (N):** Heats the resin and hardener before mixing. Improves the chemical reaction and lowers viscosity to improve the spray pattern.
- **Optional Solvent Flush Kit (G):** Flushes the mix manifold. Includes a solvent pump, mounting hardware, and solvent supply hose.

Flush Before Using Equipment

The equipment was tested with lightweight oil, which is left in the fluid passages to protect parts. To avoid contaminating your fluid with oil, flush the equipment with a compatible solvent before using the equipment. See **Empty and Flush Entire System (new system or end of job)**, page 29.

Setup



Location

						
---	---	---	--	--	--	--

The XP35, XP50, and XP70 systems are approved for use in hazardous locations only if the base model, all accessories, all kits, and all wiring meet local, state, and national codes.

1. Locate the proportioner on a level surface.
2. Position the proportioner for convenient operator access and maintenance, safe routing of air and fluid lines, and easy connection of components and accessories.
3. For permanent mounting, remove wheels and mount the frame to the floor. See **Dimensions**, page 58.
4. Ensure that the cart brake (L) is in the locked position.

Grounding

						
---	---	---	--	--	--	--

The equipment must be grounded. Grounding reduces the risk of static and electric shock by providing an escape wire for the electrical current due to static build up.

Pump: use ground wire and clamp (supplied). Loosen grounding lug locknut (W) and washer (X). Insert ground wire end (Y) into lug (Z) slot and tighten locknut securely. Connect ground clamp to a true earth ground.

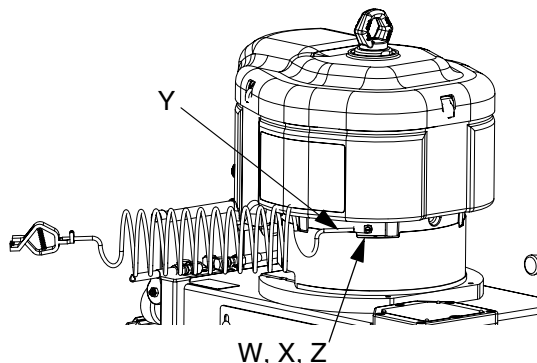

Solvent Pump: use ground wire and clamp (supplied with solvent pump). Follow instructions in pump manual.

Air and fluid hoses: use only static dissipation type hoses with a maximum of 500 ft (150 m) combined hose length to ensure grounding continuity. Check electrical resistance of hoses regularly. If total resistance to ground exceeds 29 megohms, replace hose immediately.

Air compressor: follow manufacturer's recommendations.

Spray gun: ground through connection to a properly grounded fluid hose and pump.

Fluid supply container: follow local code.



Object being sprayed: follow local code.

Solvent pails used when flushing: follow local code. Use only conductive metal pails, placed on a grounded surface. Do not place the pail on a nonconductive surface, such as paper or cardboard, which interrupts grounding continuity.

To maintain grounding continuity when flushing or relieving pressure: hold metal part of the spray gun firmly to the side of a grounded metal pail, then trigger the gun.

Wire Systems with Explosion-Proof Heaters

(Hazardous location systems only)

						
<p>If your system is rated for hazardous areas, and you have explosion-proof heaters, you must have a qualified electrician connect heater wiring. Ensure wiring and installation comply with local electrical codes for hazardous areas.</p>						

Improperly installed or connected equipment will create a hazardous condition and cause fire, explosion, or electric shock. Follow local regulations.

When explosion-proof heaters are used, ensure the wiring, wiring connections, switches, and electrical distribution panel all meet flame-proof (explosion-proof) requirements.

Refer to the Viscon HP heater manual for electrical connection instructions and guidelines in hazardous locations.

Motor Position

The motor position must be set for the volume mix ratio of the system.

NOTE: Changing the motor position does not change the mix ratio.

Check Motor Position

1. Verify that the correct pumps are mounted for your mix ratio by volume. See chart in **Bare Proportioning Pump Packages** on page 13.

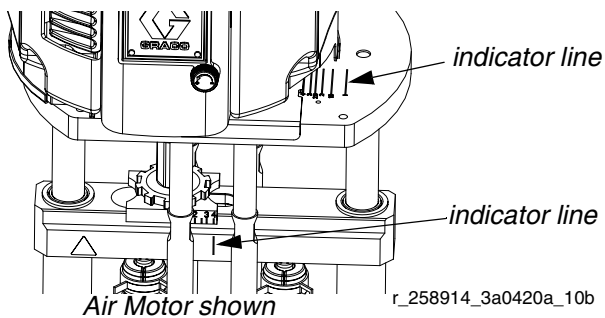

FIG. 6: Ratio indicators

2. Verify that the motor position is adjusted correctly for that mix ratio. See FIG. 6. If not, perform the following **Change Motor Position** procedure.

Change Motor Position

There are specific motor positions for each mix ratio setting. To adjust the position of the air motor:

1. Perform **Check Motor Position** procedure. If position is incorrect, continue to next step.
2. Loosen the eight fasteners and remove the two pump guards.

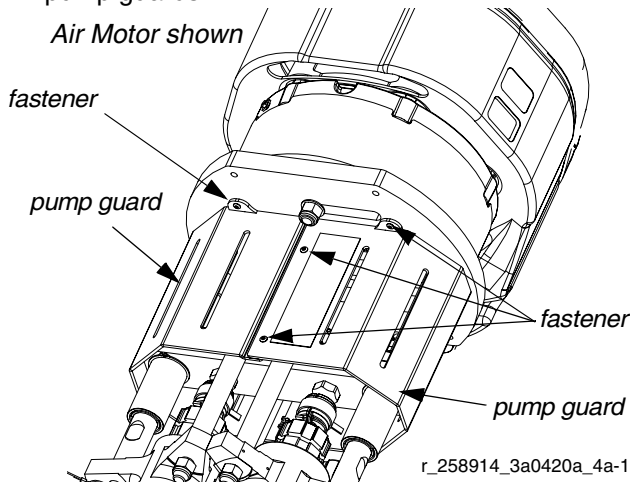

3. Place wrench on adapter rod (104) then use supplied tool to loosen the serrated yoke nut (V) above the yoke (T).



4. Loosen the three nuts (P2) below the motor tie rods.

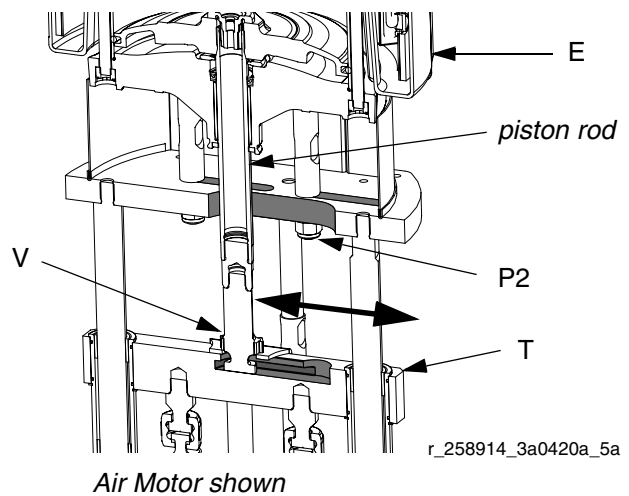

FIG. 7

5. Grab the piston rod and slide the position of the motor (E) until the indicator lines are aligned with your ratio. See FIG. 6 and FIG. 7.

NOTICE

Do not hit tie rods (P) with a steel hammer. Damage to the air motor base may result.

6. Tighten the three nuts (P2) and yoke nut (V).
7. Use supplied tool to tighten the yoke nut.
8. Install the pump guards.

Connect Air Supply

1. Connect the air supply hose to the 3/4 npt(f) air filter inlet (C).

NOTE: Use a 3/4 in. (19.1 mm) ID minimum air hose. Air consumption is 75 cfm per gallon per minute spraying. Do not use pin fitting type quick disconnects.

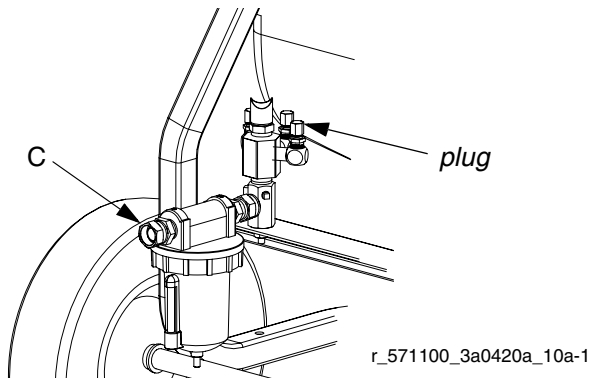

FIG. 8

2. Remove plugs as necessary for solvent pump and feed supply pump air hoses. See pump manuals for setup instructions. See FIG. 8.

Connect Static Mixers, Gun, and Hoses

NOTICE

To prevent creating a flare on the mixer tube, do not use a union swivel end on the mix tube inlet.

1. Connect the outlet of the two primary static mixer tubes with mixer elements (W) to the fluid mix hose (25), cleanup mixer (27, 28), whip hose (30), and spray gun (31). See FIG. 9.
2. Add mixed material hose as necessary between the mix hose (25) and cleanup mixer (27, 28).

Connect Fluid Hose Bundles (Remote Mix Manifold Only)

Connect additional fluid hoses to the fluid manifold (AA) when the mix manifold (AB) is remote. Hoses must be properly sized and balanced for your mix ratio. See mix manifold manual for details.

1. Connect the resin and hardener hoses to the resin and hardener outlets on the proportioner fluid manifold and resin and hardener inlets on the mix manifold.

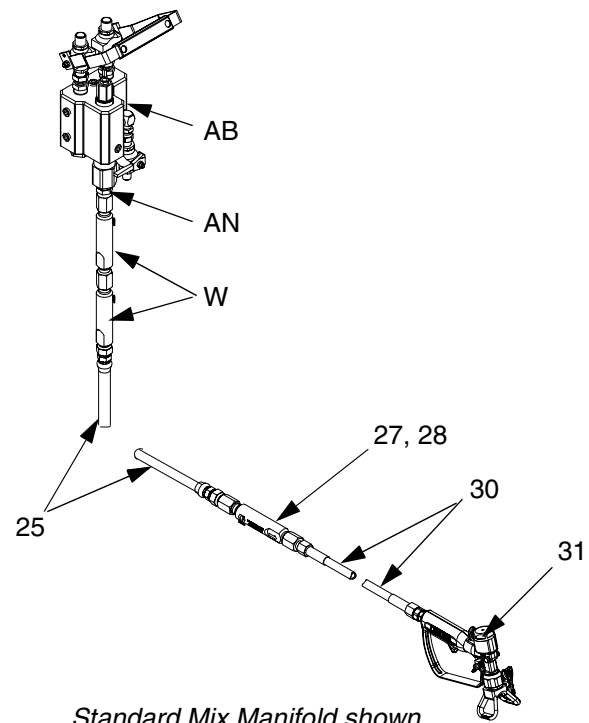

FIG. 9

Pressure Relief Procedure



Follow **Flush Mixed Material**, page 28 when you stop spraying or dispensing; and before cleaning, checking, servicing, or transporting equipment.

Relieve A and B Fluid Pressure

1. Engage the trigger lock.

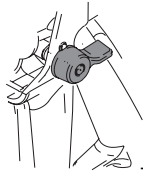

T11949a

2. Close the main air shutoff valve (CA).

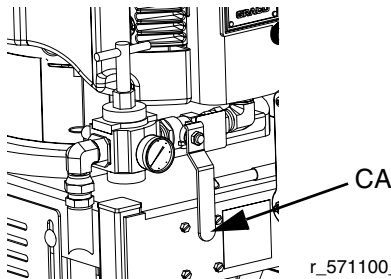

r_571100_3A0420A_11a-1

3. Shut off heaters, if used.
4. Shut off feed pumps, if used.
5. Remove the spray tip and clean.
6. Disengage the trigger lock.

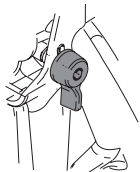

T11950a

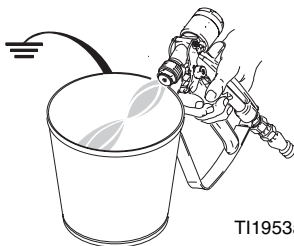

T11953a

7. Hold a metal part of the gun firmly to a grounded metal pail. Trigger the gun to relieve pressure.

8. Engage the trigger lock.
9. Close the dual shutoff handle (AE) and open the circulation handle (AC).

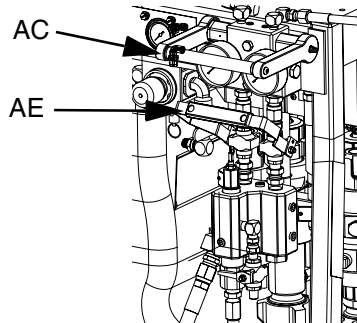

r_571101_3A0420A_9a-2

10. Always flush the mix hose after relieving A and B fluid pressure through the mix manifold. See **Flush Mixed Material**, page 28.
11. Shutoff the solvent supply pump and repeat steps 6-8 to relieve solvent pressure.

If the mixed material has already been flushed, but pressure remains on the A and B pumps, pressure can be relieved back to the hoppers (J).







- a. Close the main air shutoff valve (CA).
- b. Open the circulation handle (AC).

NOTE: For longer valve life in abrasive fluids, it is advisable to relieve high pressure out through the gun when possible.

12. If you suspect the spray tip or hose is clogged or that pressure has not been fully relieved after following the steps above, very slowly loosen tip guard retaining nut or hose end coupling to relieve pressure gradually, then loosen completely. Clear hose or tip obstruction.
13. If static mixer, whip hose, and gun cannot be flushed because of mixed and cured material, very slowly loosen static mixer tube from mix manifold outlet to relieve pressure gradually, then loosen completely. Replace or clean clogged components.

Prime Empty System

Prime A and B Fluids

						
Wear gloves when using flush solvents and/or if the fluid temperature exceeds 110°F (43°C).						

NOTE: The equipment is tested with mineral oil at the factory. If necessary, flush out the oil with a compatible solvent before spraying. See **Empty and Flush Entire System (new system or end of job)**, page 29.

Do not install the gun spray tip yet. To avoid splashing, use the lowest pressure possible to prime.

1. Condition the materials prior to adding to the hoppers (J). Ensure that the resin materials are thoroughly mixed, homogenous, and pourable prior to adding to the hopper. Stir the hardeners back into suspension prior to adding material to hopper.
2. Fill the A and B reservoirs with proper materials. Fill the A side (blue) with major volume of material; fill the B side (green) with minor volume of material (unless 1:1 mix ratio).

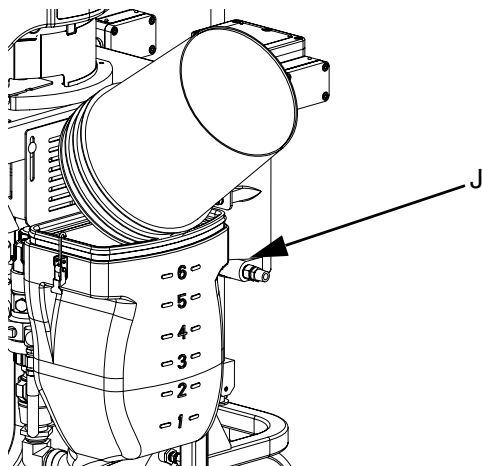

3. Move the recirculation lines (U) to empty containers.

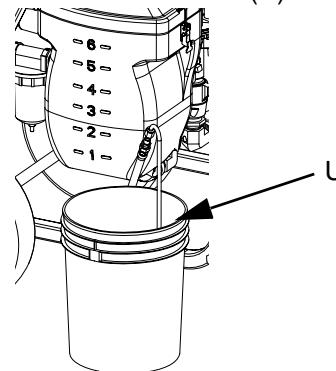

4. Close the dual shutoff handle (AE) and open the circulation handle (AC).

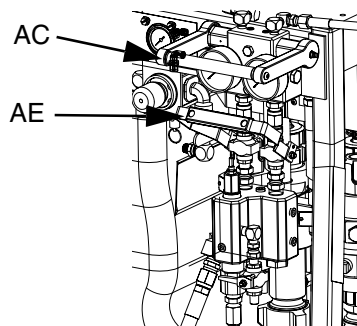

r_571101_3A0420A_9a-2

5. Open the main air shutoff valve (CA).

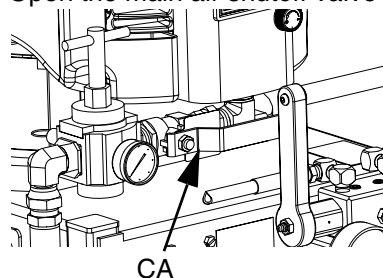

6. Slowly open the air regulator (CB).
7. Dispense fluid into the containers until clean fluid comes out of the A and B recirculation lines.
8. Decrease air pressure. Close the main air shutoff valve (CA).
9. Move the recirculation lines (U) back to the correct hopper (J).
10. If using heaters, heat fluid throughout system before spraying. See **Recirculate Prior to Spraying or Re-Prime After a Pump Runs Dry**, page 25.

Prime Solvent Flush Pump

Follow instructions if the optional solvent flush pump kit is used.



1. Connect the flush pail ground wire to a metal pail of solvent.
2. Place the siphon tube and the solvent circulation hose (BG) in the pail of solvent.

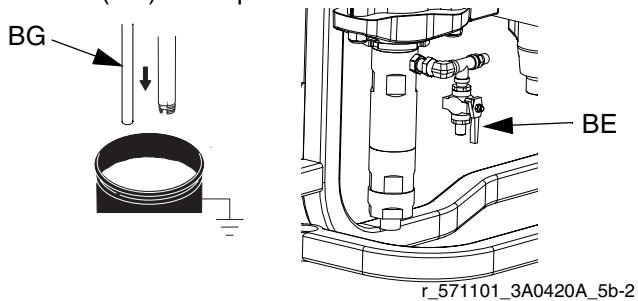

3. Open the solvent prime valve (BE) on the solvent pump (BA) outlet.
4. Open the solvent pump air valve (DA). Slowly turn the solvent pump air regulator (DB) clockwise to prime the solvent pump and route solvent back to the pail. Close the solvent pump fluid valve (BE) and air valve (DA).

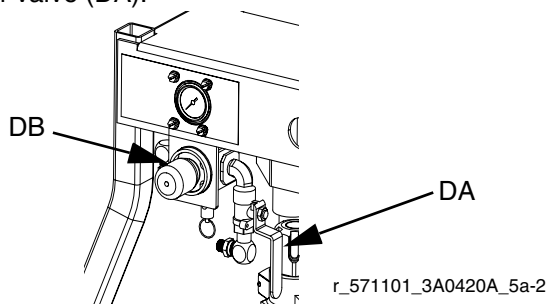

5. Open the solvent flush valve (AD) on the mix manifold.

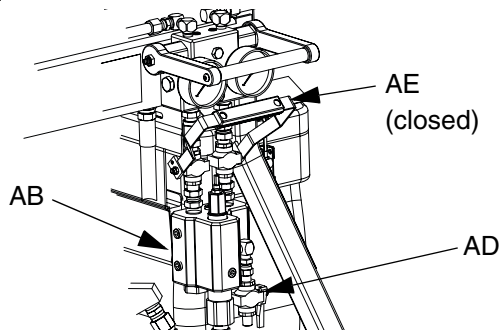

6. Ensure the trigger lock is engaged. Remove the spray tip.

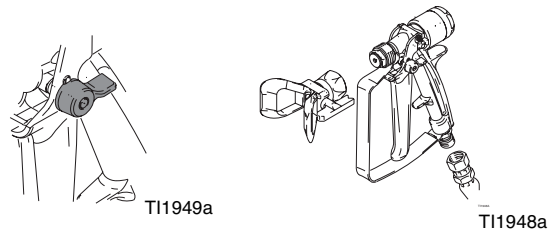

7. Disengage the trigger lock and trigger the gun into a grounded pail. Use a pail lid with a hole to dispense through. Seal around the hole and gun with a rag to prevent splash back. Be careful to keep fingers away from the front of the gun.

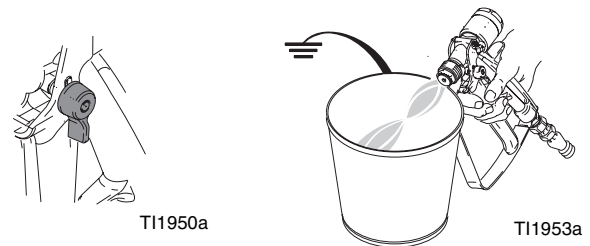

8. Open the solvent pump air valve (DA). Slowly turn the solvent pump air regulator (DB) clockwise to prime the solvent pump and push air out of the mix hose and gun. Trigger the gun until all air is purged.
9. Close the solvent pump air valve (DA) and trigger the gun to relieve pressure. Engage the trigger lock.

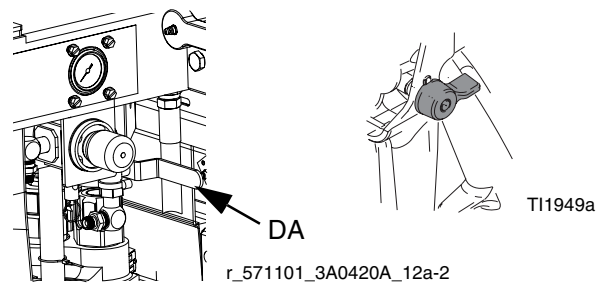

10. Close the solvent flush valve (AD).

NOTE: Solvent pump air and pressure may be left on while spraying. Never spray mixed material without the solvent pump and hose primed with solvent.

Recirculate Prior to Spraying or Re-Prime After a Pump Runs Dry

NOTE: Agitate, recirculate, and heat the material only as necessary to avoid mixing air into the fluid.

Use the recirculation mode when heating the material is required. Note the temperature at the top of the heater (outgoing or back to the hopper). When the thermometer reaches operating temperature, the material is ready to spray.

If using a system that does not require heat, recirculation is still required prior to spraying. Recirculation ensures that any settled fillers are mixed in, the pump lines are fully primed, and the pump check valves are operating smoothly.

Recirculation also allows you to re-prime one side that has run dry.

1. Follow **Prime Empty System**, page 23.
2. Close the dual shutoff handle (AE).

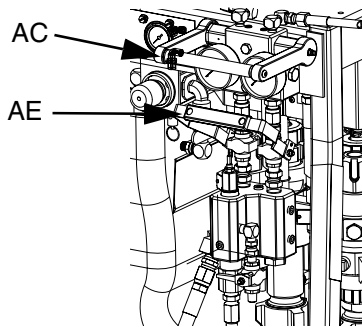

r_571101_3A0420A_9a-2

3. Ensure the recirculation hoses (U) are in the correct hoppers (J).

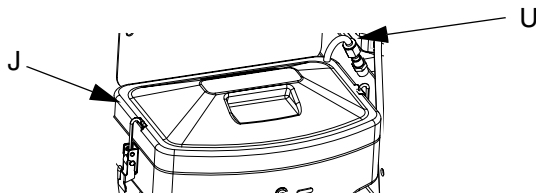

4. Open the circulation valve handle (AC).

5. Turn down the air pressure regulator (CB) and then open the main air shutoff valve (CA). Use the air pressure regulator to slowly increase the air pressure to the pumps until they start running slowly.

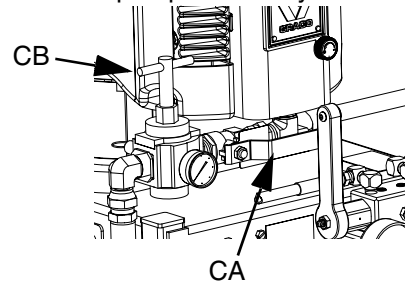

6. Run the pumps for a few minutes or until the material has reached the desired temperature. See **Heat Fluid**.
7. Close the main air shutoff valve (CA).

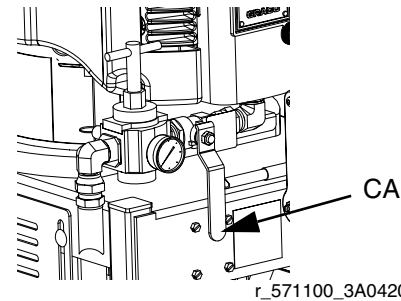

r_571100_3A0420A_11a-1

8. See **Spray**, page 26.







Heat Fluid

To heat fluid evenly throughout the system:

1. Circulate the fluid at approximately 1/2 gpm (10-20 cycles/min.) to raise the temperature of the hoppers to 80-90° F (27-32° C).
2. Decrease the circulation rate to approximately 0.25 gpm (5 cycles/min.) to increase the heater outlet temperature to match the spray temperature.

NOTE: Circulating the fluid too quickly without decreasing the circulation rate will increase only the hopper temperature. Similarly, circulating fluid too slowly will increase only the heater outlet temperature.

Spray

					
Wear gloves when using flush solvents and/or if fluid temperature exceeds 110°F (43°C).					

NOTE: After the first day of spraying follow Pressure Relief Procedure, page 22, and tighten the throat packing nuts on both pumps.

1. If heaters are used, turn them on. To adjust the heater temperature, refer to the Viscon HP manual for instructions, and the **Heat Fluid** section, page 25. Circulate as necessary.
2. Close the circulation handle (AC) and the solvent flush valve (AD). Open the dual shutoff handle (AE).

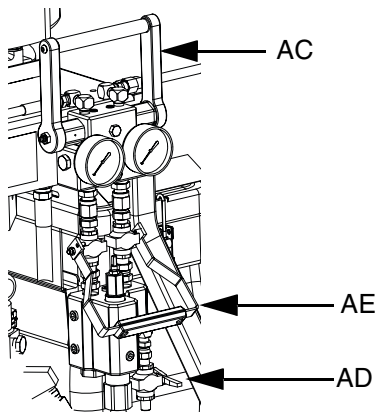

3. Adjust the main air regulator (CB) to 30 psi (0.21 MPa, 2.1 bar).
4. Remove tip. Disengage the trigger lock and trigger the gun into a grounded metal pail. Use a metal pail lid with a hole to dispense through to avoid splashing. Dispense out of the mix hose until a well mixed coating flows from the gun.

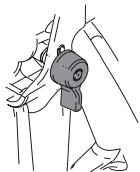

T11950a

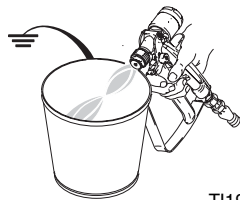

T11953a

5. Engage the trigger lock. Install the tip on the gun.

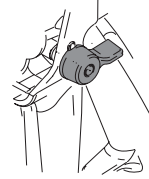

T11949a

6. Adjust the main pump air regulator (CB) to the necessary spraying pressure and apply a coating to a test panel.

NOTE: Run system verification tests everyday. See page 31.

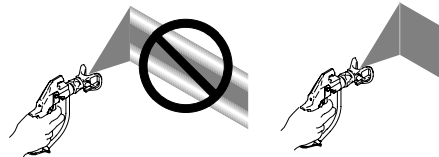

7. Excess pressure increases overspray and pump wear.
8. Check and record gauge readings frequently during operation. A change in gauge readings indicates a change in system performance.

NOTE:

- **A pressure drop occurs during pump stroke changeover. It should be quick and synchronous.**
 - **Flush the mix manifold as necessary during the day's operation.**
9. Follow **Flush Mixed Material**, page 28 when you are finished spraying or before potlife expires.

NOTE: Mixed material potlife or working time decreases with increased temperature. Pot life in the hose is much shorter than the dry time of the coating.

B Side Mix Manifold Restriction

The B side restrictor (AJ) controls “lead/lag” ratio errors of the A and B flow into the static mixer tubes. These errors occur momentarily when the gun opens. The error is caused by differences in viscosity, volume, and hose expansion.

The restrictor is used primarily when the mix manifold is positioned remote from the machine with a short mix hose to the spray gun. It can also be used in the ratio check procedure.

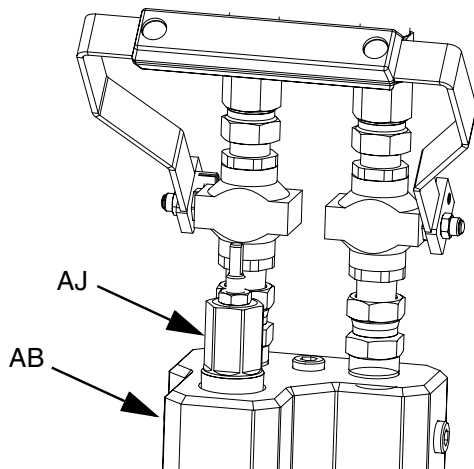

If the mix manifold (AB) is mounted on the machine, you do not need to adjust the restrictor. Leave open two turns minimum.

To Adjust the Restrictor:

Adjust the restrictor stem clockwise while spraying until you see a slight rise in the B side pressure gauge. The point where the pressure starts to rise is a good adjustment setting.

NOTE: Unless you are dispensing directly out of the mix manifold and mixer, this is an approximate adjustment.

See the mix manifold manual for more information.

Flush Mixed Material



Flush the mix manifold when any of the following situations occur.

- breaks in spraying
- overnight shutdown
- mixed material in system approaching end of potlife

To flush the entire system, see **Empty and Flush Entire System (new system or end of job)**, page 29.

Flush Mix Manifold, Hose, and Spray Gun

If your system doesn't include a solvent flush pump, see step 2 of **Empty and Flush Entire System (new system or end of job)**, page 29.

Turn off heaters. Allow heater and heated hoses to cool.

Use Optional Solvent Pump

1. Close the main air shutoff valve (CA) to turn off the system. Engage trigger lock. Remove the spray tip and soak in solvent.

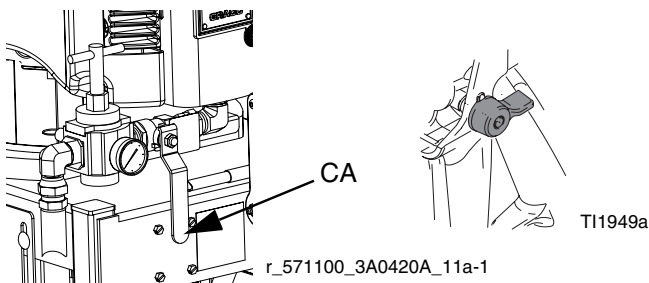

2. Close the dual shutoff handle (AE).
3. Open the solvent pump air valve (DA). Slowly turn the solvent pump air regulator (DB) clockwise to increase air pressure.

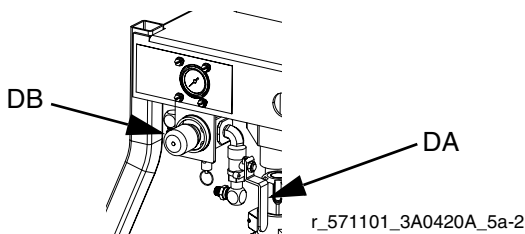

4. Open the solvent flush valve (AD).

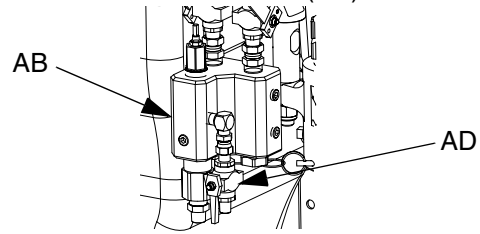

5. Disengage the trigger lock and trigger gun into a grounded pail. Use a pail lid with a hole to dispense through. Seal around the hole and gun with a rag to prevent splash back. Be careful to keep fingers away from the front of the gun. Continue flushing until clean solvent dispenses.

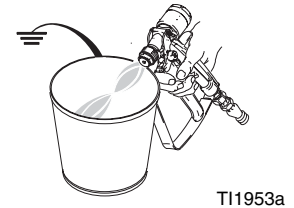
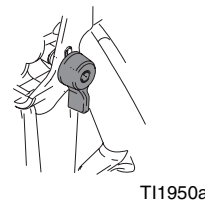

6. Close the solvent pump air valve (DA). Trigger the gun to relieve pressure. Close the solvent flush valve (AD) after relieving the pressure.

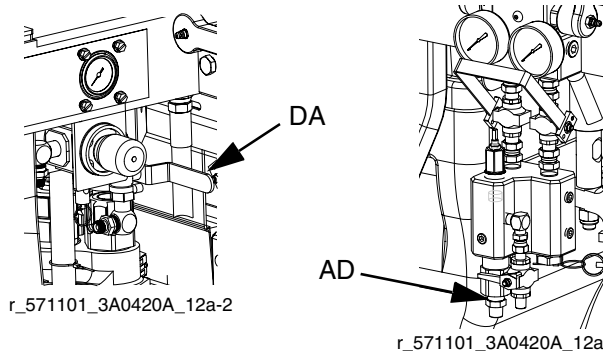

7. Follow **Pressure Relief Procedure**, page 22.
8. Engage the trigger lock. Disassemble and clean the spray tip with solvent by hand. Reinstall on the gun.

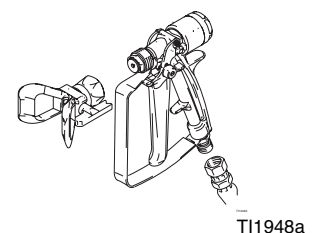
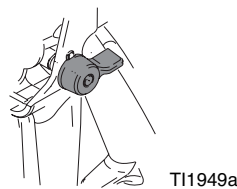

Empty and Flush Entire System (new system or end of job)



NOTE:

- If the system includes heaters and heated hose, turn them off and allow to cool before flushing. Do not turn on the heaters until the fluid lines are clear of solvent.
- Cover fluid containers and use the lowest possible pressure when flushing to avoid splashing.
- Before color change or shutdown for storage, circulate the solvent at a higher flow rate and for a longer time. Change the solvent when it gets dirty.
- To only flush the fluid manifold, see Flush Mix Manifold, Hose, and Spray Gun, page 28.
- If the machine is inoperable, use drain plugs on the pump inlet fittings.

Guidelines

Flush new systems if the coating materials will be contaminated by mineral oil.

Flushing will help prevent materials from settling or gelling in the pumps, lines, and valves. Flush the system when any of the following situations occur.

- anytime the system will not be used for more than one week (depending on materials used)
- if the materials used have fillers that will settle
- if using materials that are moisture sensitive before servicing
- if the machine is going into storage, replace the flush solvent with light oil. Never leave the equipment empty of any fluid.

Procedure

1. Follow **Prime Empty System**, page 23 and **Flush Mix Manifold, Hose, and Spray Gun**, page 28, as required.

2. Engage the trigger lock. Turn the main pump air regulator (CB) fully counter-clockwise to shut off.

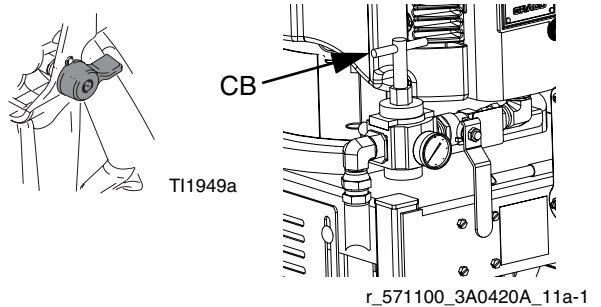

3. Move the recirculation lines (U) to separate fluid containers to pump remaining fluid out of the system.

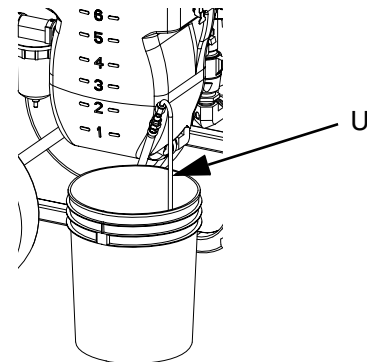

4. Open the circulation handle (AC). See FIG. 2 on page 15.
5. Increase the main pump air regulator (CB) pressure to 20 psi (138 kPa, 1.38 bar).
6. Open the main air shutoff valve (CA).

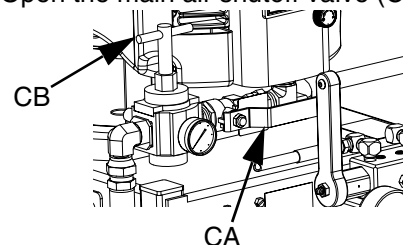

NOTE: If the system does not start with static pressure, increase the air pressure by 5 psi (35 kPa, 0.35 bar) increments. To avoid splashing, do not exceed 35 psi (241 kPa, 2.4 bar).

Shutdown

7. Run the pumps until the A and B hoppers (J) are empty. Salvage the material in separate, clean containers.
8. Close the main air shutoff valve (CA).

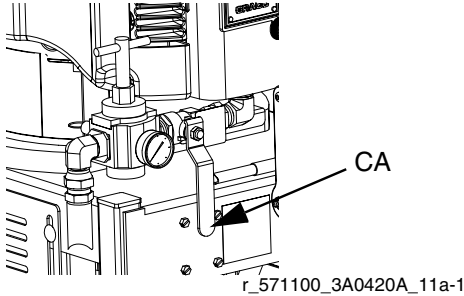

9. Wipe the hoppers (J) clean, then add solvent to each. Move the circulation lines (U) to waste containers and push out the dirty fluids.
10. Move the recirculation lines (U) back to the hoppers. Continue recirculating until the system is thoroughly flushed.

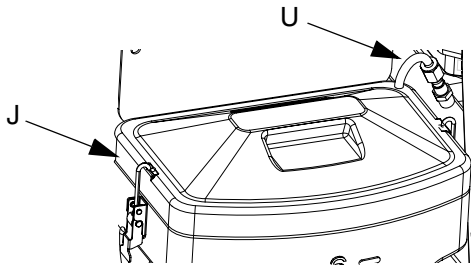

11. Close the circulation handle (AC) and open the dual shutoff handle (AE).
12. Dispense fresh solvent through the mix manifold valves and out the gun.
13. Turn off the air motors and follow **Pressure Relief Procedure**, page 22.

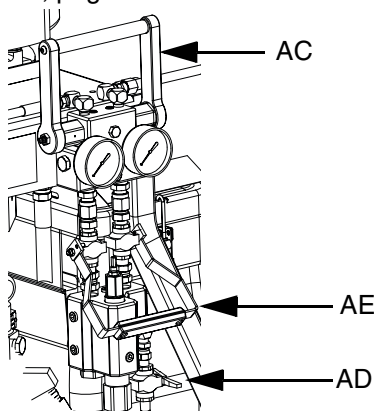

14. Close the dual shutoff handle (AE).
15. Remove pump fluid filters, if installed, and soak in solvent. Clean and replace the filter cap. Always replace the filter o-rings.

NOTE:

- **Fill the A and B pump packing nuts with TSL. Also, always leave some type of fluid, such as solvent or oil, in the system to prevent scale build up. This build up can flake off later. Do not use water.**
- **If machine is set up with a remote mix manifold, the A and B hose can be disconnected from the mix manifold, and secured in back of each hopper for circulation of flush solvent.**
- **Change the flush solvent at least once until it circulates clean.**
- **Always keep the A side and B side flush solvent separate.**

Shutdown

1. Follow **Pressure Relief Procedure**, page 22.
2. Flush mix manifold, hoses, and gun. See **Flush Mix Manifold, Hose, and Spray Gun**, page 28.
3. Close the main air shutoff valve (CA).

Park

1. Open the circulation handle (AC) and adjust the air regulator (CB) so that the pump runs slowly.
2. Close the circulation handle (AC) when the pump is at the bottom of the stroke.
3. Close the air regulator (CB) and open the circulation handle (AC).

System Verification

Graco recommends running the following tests daily.

Check for Normal Operation

Every time you start spraying:

- Watch the fluid gauges (AF). A pressure drop occurs during pump stroke changeover. It should be quick and synchronous.
- Stop the pumps on the upstroke. Check that both gauges hold pressure for at least 20 seconds. See **Pump Troubleshooting** on page 34.

NOTE: If one gauge drops, the others will rise.

- Stop the pumps on the downstroke. Check that all gauges hold pressure.
- If using feed pumps, check that both feed pumps run during the proportioner upstroke.

Mix and Integration Tests

Use the following tests to check for proper mix and integration.

Butterfly Test

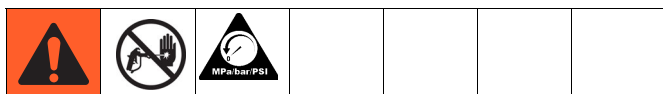

At low pressure, and with the spray tip reversed, dispense a 1/2 in. (12.7 mm) bead of material onto foil until multiple changeovers of each pump have occurred. Fold the sheet of foil over the fluid then peel it back and look for unmixed material (appears marble-like), or color changes.

Curing Test

Spray a single continuous pattern on foil at typical pressure setting, flow rate, and tip size until multiple changeovers of each pump have occurred. Trigger and de-trigger at typical intervals for the application. Do not overlap or cross over your spray pattern.

Check curing at various time intervals, listed on the material data sheet. For example, check for dry to touch by running your finger along the test pattern's entire length at the time listed on the data sheet.

NOTE: Spots that take longer to cure indicate insufficient pump loading, leakage, or lead/lag errors at a remote mix manifold.

Appearance Test

Spray material onto foil. Look for variations in color, gloss, or texture that may indicate improperly catalyzed material.

Monitor Fluid Supply

NOTICE
To prevent pumping air into the system, which causes incorrect proportioning, never allow the feed pump or solvent pump containers to run dry.

An empty pump will quickly accelerate to a high speed, and may damage itself and the other displacement pump because it causes a pressure rise in the other pump. If a supply container runs dry, stop the pump immediately, refill the container, and prime the system. Be sure to eliminate all air from the system.

Check Pot Life

Check the fluid manufacturer's instructions for fluid pot life at your fluid temperature. Flush mixed fluid out of the mix manifold, hose, and gun before pot life time expires, or before a rise in viscosity affects the spray pattern.

Ratio Check

Check the ratio at the mix manifold after any changes to the proportioning system. Use Ratio Check Kit 24F375 to check the ratio at the mix manifold. See manual ratio check kit manual for instructions and parts.

NOTE: To prevent an inaccurate ratio check when feed pumps are used in your system, the feed pressure cannot be more than a maximum of 25% of the proportioner outlet pressure. High feed pressure can float the proportioner pump check balls, resulting in an inaccurate ratio check. There must be back pressure on both sides of the mix manifold when checking the ratio.

Maintenance

Hose Electrical Resistance

Check electrical resistance of hoses regularly. If total resistance to ground exceeds 29 megohms, replace hose immediately.

Filters

Once a week check, clean, and replace (if needed) the following filters.

- Both pump filters; see lower manual for instructions.
- Main air inlet manifold filter; see **Replace Air Filter Element**, page 36.
- Spray gun handle filter; see spray gun manual.

Seals

Once a week, check and tighten throat seals on both pumps. See table for torque specifications. Be sure to follow the **Pressure Relief Procedure**, page 22, prior to tightening seals. There must be zero pressure on the pumps when adjusting.

Pump Size	Torque Specification
All	25-30 ft-lb (34-41 N•m)

Cleaning Procedure



1. Ensure all equipment is grounded. See **Grounding**, page 18.
2. Ensure the area where the system will be cleaned is well ventilated and remove all ignition sources.
3. Turn off all heaters and allow equipment to cool.
4. Flush mixed material. See **Flush Mixed Material**, page 28.
5. Relieve pressure. See **Pressure Relief Procedure**, page 22.

6. Shutdown the sprayer and turn off all power. See **Shutdown**, page 30.
7. Clean the external surfaces only using a rag soaked in solvent that is compatible with the spray material and surfaces being cleaned.
8. Allow enough time for the solvent to dry before using the system.

Recommended Spare Parts

Keep these spare parts on hand to reduce downtime. See **Recommended Spare Parts**, page 54.

Change the Mix Ratio

In order to change the mix ratio, one or both pumps need to be replaced, the air motor needs to be re-positioned, and the over pressure relief valves may need to be installed.

NOTE: Only Xtreme XP lower pumps come with a rod coupling.

1. Check the **Varying Parts** table on page 51 for the correct pump sizes.
2. Remove and replace pump. See page 35.
3. Adjust the position of the air motor. See page 20.
4. **If changing from one type of XP system to another (for example - changing from XP35 to XP70 or from XP70 to XP35):** remove the existing over pressure relief valves (302) and install the correct valves for the new system type. See **Replace Over Pressure Relief Valves** on page 38.
5. Change air pressure relief valve as required, depending on ratio. See air relief valve (64) in tables starting on page 46.

Troubleshooting



✘ *Fluid ratio will be wrong.*

◆ *Purge all air from system before proportioning fluids.*

Problem	Cause	Solution
System stops or will not start.	Air pressure or volume too low.	Increase; check air compressor.
	Closed or restricted air line or air valve.	Open or clean.
	Fluid valves closed.	Open.
	Clogged fluid hose.	Replace.
	Air motor worn or damaged.	Repair air motor; see 311238.
	Displacement pump stuck.	Repair pump; see 311762.
System speeds up or runs erratically.	Fluid containers are empty.◆	Check often; keep filled.
	Air in fluid lines.◆	Purge; check connections.
	Displacement pump parts worn or damaged.	Repair pump; see 311762.
Pump operates, but resin output pressure drops on upstroke.✘	Dirty, worn, or damaged resin pump piston valve or piston packings.	Clean, repair pump; see 311762.
Pump operates, but resin output pressure drops on downstroke.	Dirty, worn, or damaged resin pump intake valve.	Clean, repair pump; see 311762.
Pump operates, but resin output pressure drops on both strokes.✘	Hardener output restriction.	Clean, unplug hardener side. Open manifold restrictor.
	Fluid supply low.◆	Refill or change container.
Pump operates, but hardener output pressure drops on upstroke.✘	Dirty, worn, or damaged hardener pump piston valve or piston packings.	Clean, repair pump; see 311762.
Pump operates, but hardener output pressure drops on downstroke.✘	Dirty, worn, or damaged hardener pump intake valve.	Clean, repair pump; see 311762.
Pump operates, but hardener output pressure drops on both strokes.	Resin output restriction.	Clean, unplug resin side.
	Fluid supply low.◆	Refill or change container.
Fluid leak in packing nut.	Loose packing nut or worn throat packings.	Tighten; replace; see 311762.
Fluid leak under packing nut	Packing cartridge o-ring.	Replace o-ring; see 311762
Relief valve (AM) leaks back to supply, opens too soon, or will not close.	Relief valve is dirty or damaged.	Replace over pressure relief valve (302)
No pressure on hardener side; fluid leaking from hardener pump outlet rupture disc fitting.	Overpressure rupture disk blown.	Determine cause of overpressurization and correct. Replace rupture disk assembly 258962 (see page 51) and over pressure relief valve (302).
Pressure and flow surges on upstroke.	Feed pressure too high. Every 1 psi of feed pressure adds 2 psi during upstroke.	Reduce feed pressure. See Technical Data , page 57.

Problem	Cause	Solution
Fluid outlet pressure gauges split only at the top changeover (if one gauge drops the other will rise).	Not fully loading one side on upstroke.	Increase feed pressure on side that dropped. Increase feed hose size. Clean inlet strainer or hopper screen.
	Air mixed in fluid from excessive agitation or circulation.	Flush and add new fluid.

Pump Troubleshooting

This chart uses proportioning fluid gauges to determine pump malfunctions. Observe the gauge readings during the stroke direction indicated by the bold arrow, and immediately after closing the gun or mix manifold. Refer to other manuals to troubleshoot individual components.

TROUBLE AREA: Resin Pump Leakage

1. Throat packing
2. Piston packing
3. Piston ball check

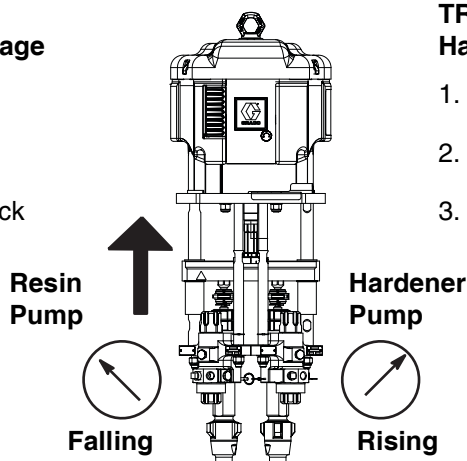

r_258914_3a0420a_11a

TROUBLE AREA: Hardener Pump Leakage

1. Throat packing
2. Piston packing
3. Piston ball check

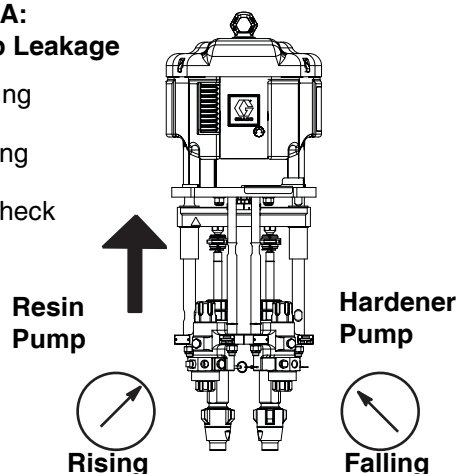

r_258914_3a0420a_11a

TROUBLE AREA: Resin Pump Leakage

1. Throat packing
2. Intake ball check

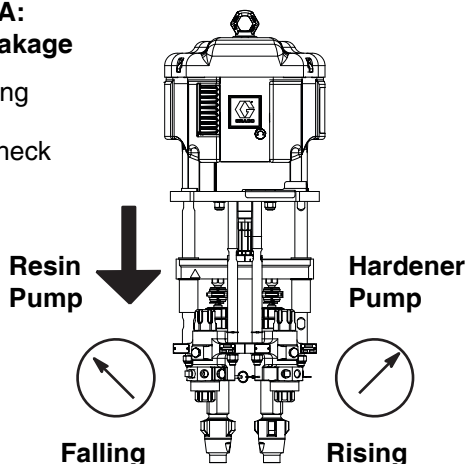

r_258914_3a0420a_10a

TROUBLE AREA: Hardener Pump Leakage

1. Throat packing
2. Intake ball check

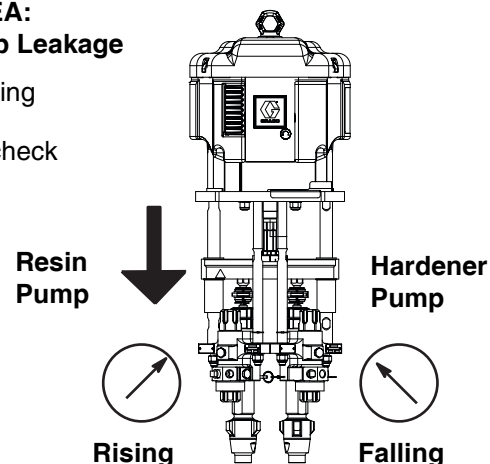

r_258914_3a0420a_10a

Repair



Follow **Shutdown** procedure on page 30, which includes flushing, if service time may exceed pot life time, before servicing fluid components, and before transporting system to a service area.

Pump Assembly

The displacement pumps and air motor may be removed and serviced separately or the entire pump and motor assembly can be removed with a hoist.

Remove Pump Assembly

1. Stop the pumps near the bottom of their stroke. Follow **Shutdown**, page 30.
2. Disconnect all hoses from the pump assembly.
3. If hoppers are installed, disconnect the hopper fluid lines from the pump fluid inlet. See **Hoppers**, page 40.

NOTE: The hopper and hopper bracket do not need to be removed from the cart.

4. Remove screws (6) and washers (5) under the tie plate (101).
5. Use hoist to remove the pump assembly by the lift ring and carefully lift out of cart (1).

Remove Displacement Pump

1. Follow **Shutdown**, page 30.
2. If hoppers are installed, remove the hopper and hopper bracket from the cart. See **Hoppers**, page 40.
3. If feed pumps are installed, close the inlet ball valve. Remove inlet union (61).

4. Remove the spring clamp (130) and coupling (119 or 120).

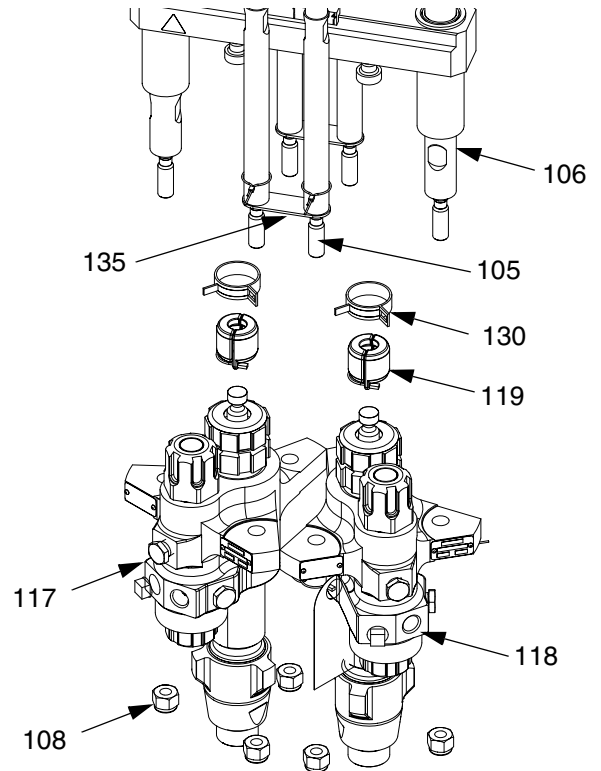

r_258914_3a0420a_5a

5. Use a wrench to hold the tie rod (105, 106) flats to keep the rods from turning. Unscrew the nuts (108) from the tie rods and carefully remove the displacement pump (117 or 118) and lower straps (135).
6. Refer to the Xtreme Displacement Pump manual to service or repair the displacement pump.
7. Follow the steps in reverse order to reinstall the displacement pump.

NOTE: Torque nuts (108) to 50-60 ft-lb (68-81 N•m).

Remove Motor

1. Stop the pumps near the bottom of their stroke. Follow **Shutdown**, page 30.
2. Disconnect the air line from the air motor (103).
3. Remove the air motor rod cover (121) and pump guards (122).

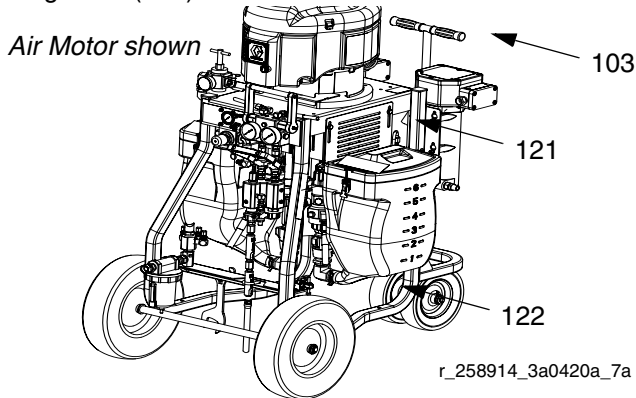

4. Use a wrench to hold the tie rod (102) flats to keep the rods from turning. Unscrew the nuts (108) and washers (107) from the tie rods.

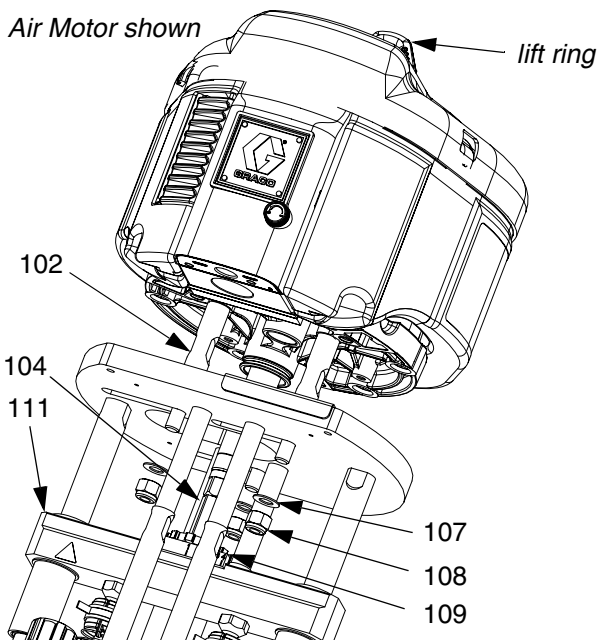

5. Place a wrench on adapter rod (104). Use tool (70) to loosen the serrated yoke nut (109) that holds the air motor (103) above the yoke (111).
6. Face the front of the machine and slide the air motor (103) to the opening in the yoke (111).
7. Use a hoist to remove the air motor by the lift ring.

8. Refer to the air motor manual to service or repair the air motor.
9. Follow the steps in reverse order to reinstall the air motor.

NOTE: Position air motor for correct mix ratio. See Motor Position on page 20 for instructions. Torque nuts (108) to 50-60 ft-lb (68-81 N•m).

Air Controls

See FIG. 10 on page 37.

Replace Air Control Assembly

1. Close the main air shutoff valve on the air supply line and on the system. Depressurize the air line.
2. Disconnect the air motor air lines and system air line.
3. Remove the nut (8) and washer (5). Remove the bottom air control manifold assembly from the cart.
4. Loosen the upper air control assembly from the air motor.
5. Follow the steps in reverse order to reinstall the new air control assembly.

Replace Air Filter Element

1. Close the main air shutoff valve on the air supply line and on the system. Depressurize the air line.
2. Unscrew the serrated ring on filter bowl (210).
3. Remove and replace the filter element (210a). See **Air Controls, 258983**, page 52.

Replace System Air Regulator

1. Close the main air shutoff valve on the air supply line and on the system.
2. Disconnect air motor air lines and system air line.
3. Remove the regulator assembly (201) and replace with new regulator. See **Air Controls, 258983**, page 52.
4. Follow the steps in reverse order to reassemble.

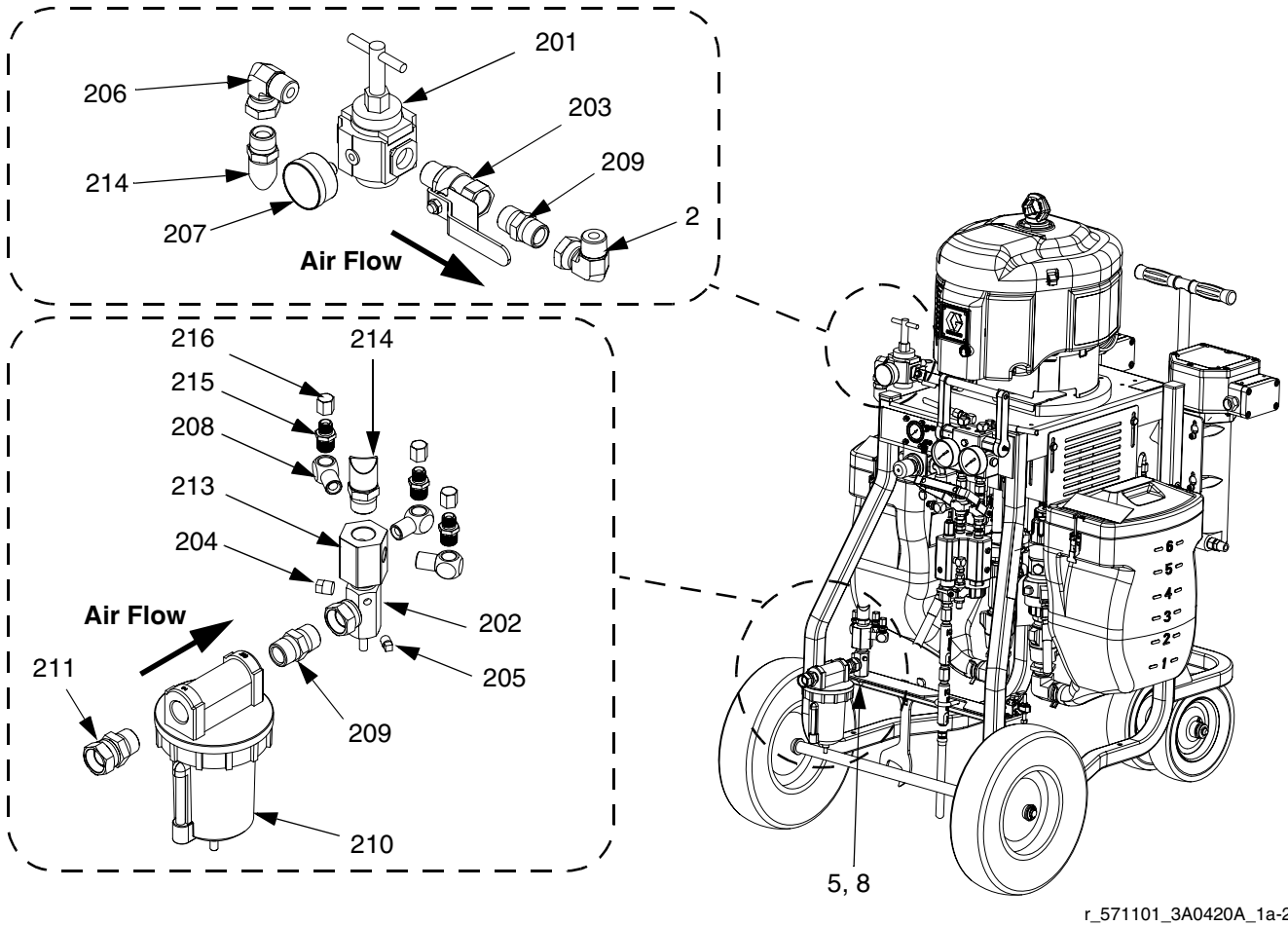
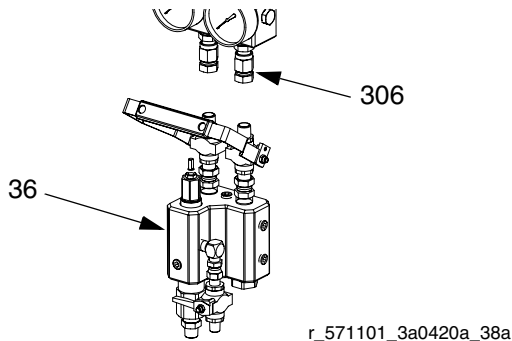

FIG. 10: Air Control Assembly 258983

Mix Manifold Assembly

1. Follow **Pressure Relief Procedure**, page 22.
2. Disconnect the fluid hose (25) and the flush hose from the mix manifold (36).
3. Loosen the union fittings (306) that connect to the mix manifold adapter fittings.
4. Remove the mix manifold assembly (36).
5. See mix manifold manual for service and repair instructions.



Fluid Circulation Manifold with Over Pressure Relief Valves

See FIG. 11.

1. Flush before repairing equipment, if possible. See **Empty and Flush Entire System (new system or end of job)**, page 29.
2. Follow **Pressure Relief Procedure**, page 22.
3. Disconnect all fluid hoses from the fluid circulation manifold (35).
4. Remove the mix manifold if it is assembled to the fluid circulation manifold. See **Mix Manifold Assembly** for instructions.
5. Loosen the two screws (37) that secure the manifold (35) to the cart (1).
6. Remove the two screws (37) and fluid circulation manifold (35) from the cart (1).

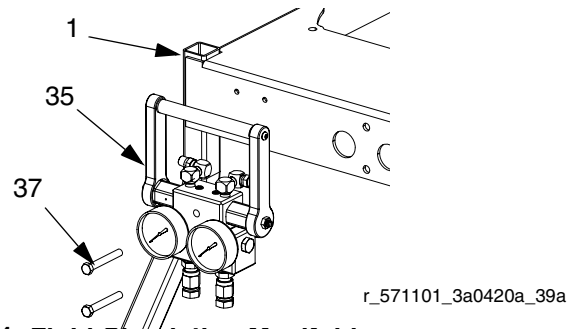
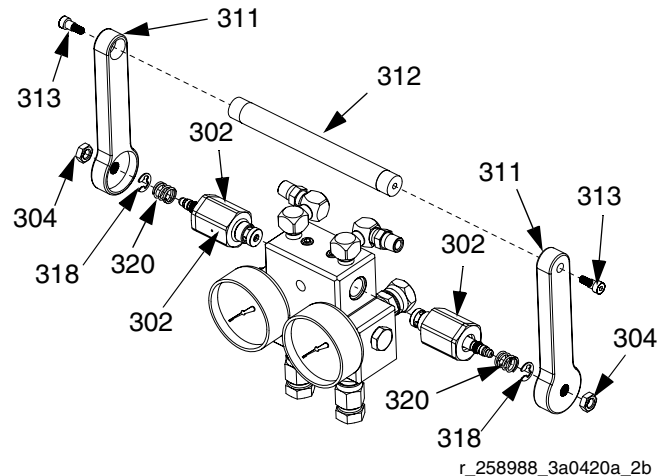

FIG. 11: Fluid Circulation Manifold

Replace Over Pressure Relief Valves

1. Flush before repairing equipment, if possible. See **Empty and Flush Entire System (new system or end of job)**, page 29.
2. Follow **Pressure Relief Procedure**, page 22.
3. Ensure handle (312) is in the down position. Remove the screws (313), jam nut (304), handles (311), handle rod (312), clips (318), and springs (320).



4. Unscrew both over pressure relief valves (302) from the manifold.

NOTE: The correct over pressure relief valve must be used on all systems. Choose the correct color coded valve from the chart on page 39.

5. Apply blue threadlock to new over pressure relief valves (302) and install in the manifold. Torque to 28-32 ft-lb (38-43 N•m).
6. Place a spring (320) over each valve stem. Place a clip (318) in each valve stem groove to retain the springs.

7. Slide handle (311) onto valve stem and rotate approximately 90° until you feel it fully lock against the valve seat. Repeat for opposite side.
 8. Remove handle then place handle (311) on valve stem (302) at the vertical, or near vertical, position.
 9. Apply blue threadlock on the nut (304) threads and tighten the handle against the spring (320) and clip (318). Torque to 70-80 in-lb (7.9-9 N•m).
 10. Place the rod (312) and the second handle (311) on second valve stem aligned with the opposite handle.
 11. Repeat step 9.
 12. Install two screws (313) in handles (311).
 13. Check operation of the handle and valves.
 14. Operate the handle in and out of the spray and circulate positions.
 15. Check for clearance with fittings.
- NOTE:**
- Both valves should settle firmly into the spray position inward against the seats in the valve.
 - Both valve stems should rotate out to their most extended positions when the handle is pulled down to the circulate position.

Fluid Circulation Manifold Replacement Guide

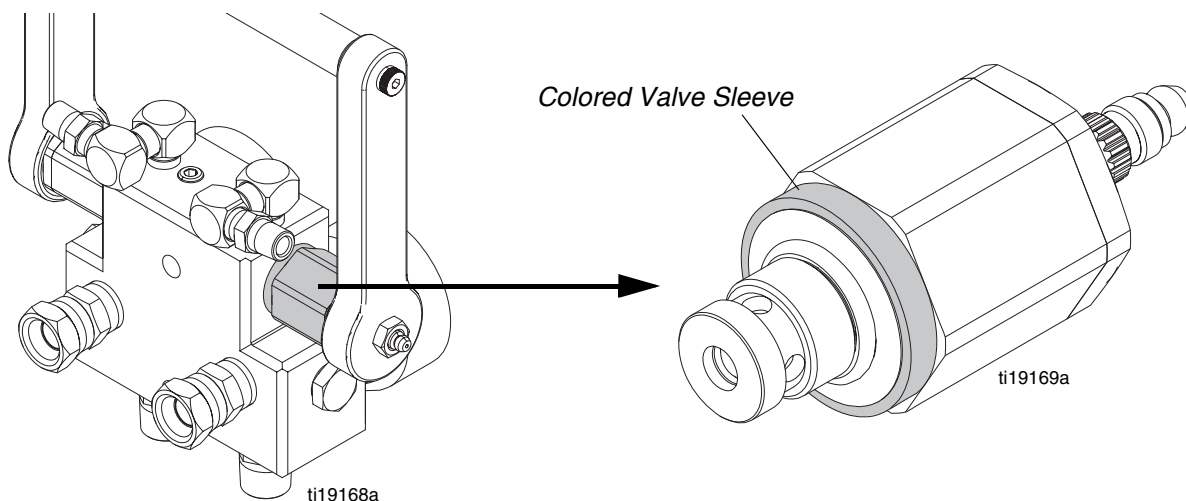

Circulation Manifold (35) Part No.	Relief Valve (302) Part No.	Valve Sleeve Color	Target Opening Pressure psi (MPa, bar)	Use with:
262784	262808	Purple	5300 (37, 365)	All XP35 models, XP-h models 284101, 284201, 284301, 284401
262783	262809	Gold	7100 (49, 490)	All XP50 models, XP-h models 284102, 284202, 284302, 284402
262806	262520	Silver	9250 (64, 638)	All XP70 models, XP-h models 284103, 284203, 284303, 284403

NOTE: Original XP70 valves did not include a silver valve sleeve. When replacing these original valves, replace with the current valves that have the silver valve sleeve.

Hoppers

1. If material is in the hopper pump out the remaining material.
2. If the pump has failed:
 - a. Place a waste container beneath the plug on fitting (61). Remove the plug.
 - b. Drain all material from hopper into the waste container.
 - c. Install plug after material is no longer draining from fitting (61).

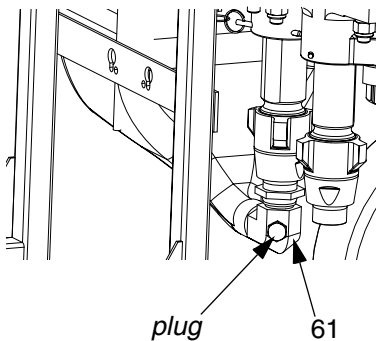

r_571101_3a0420a_41a

3. Follow **Pressure Relief Procedure**, page 22.
4. Loosen fitting (61) and disconnect hopper from pump.
5. Remove the recirculation line from the hopper and place in a waste container.

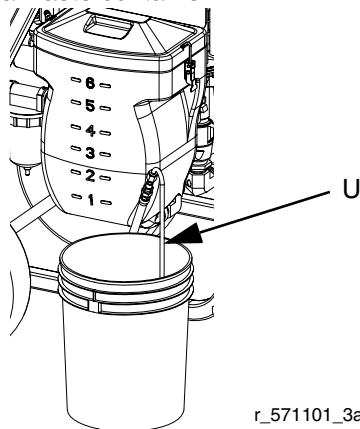

r_571101_3a0420a_18a

6. Lift the hopper off of the mounting bracket.
7. Repeat for second hopper.

Optional Solvent Pump

1. Follow **Pressure Relief Procedure**, page 22.
2. Disconnect the fluid line and air lines from the solvent pump.
3. Loosen the four screws that attach the solvent pump to the cart (1). Lift and pull pump from the slots.

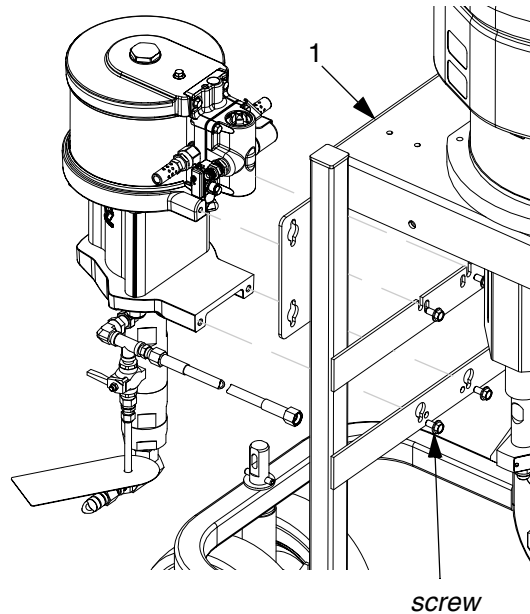

4. Refer to the Merkur Pump Assembly manual to service or repair the solvent pump.
5. Follow the steps in reverse order to reinstall the solvent pump.

Optional Fluid Heaters

NOTE: Wiring for heaters is not provided. See the Viscon HP heater manual for wiring, repair, and parts information for explosion-proof heaters.

Service and Repair

1. Follow **Pressure Relief Procedure**, page 22.
2. Disconnect the fluid lines and electrical wiring from the fluid heater.
3. Refer to the Viscon HP heater manual to service or repair. Refer to the heater adapter kit manual 406861 for installation instructions.
4. Reconnect the fluid lines and electrical wiring.

Replace

1. Follow steps 1 through 2 in the **Fluid Heaters Service and Repair** section.
2. Loosen the four mounting screws, lock washers, and plain washers on back of the heater. Slide the heater up and remove from the cart.
3. Replace the heater. Follow the steps in reverse order to install a new heater.

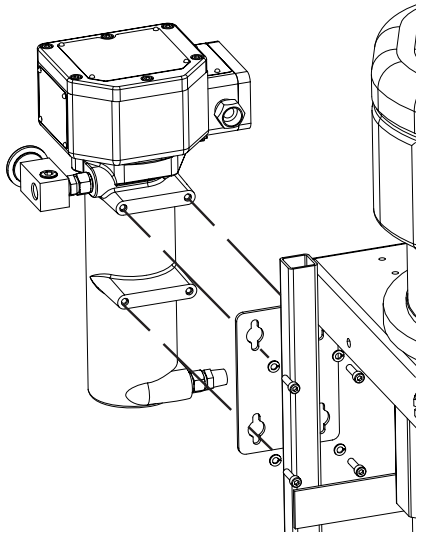

r_571101_3a0420a_42a

Parts

Cart-Mounted System

1. Apply anaerobic pipe sealant to all non-swiveling pipe threads.

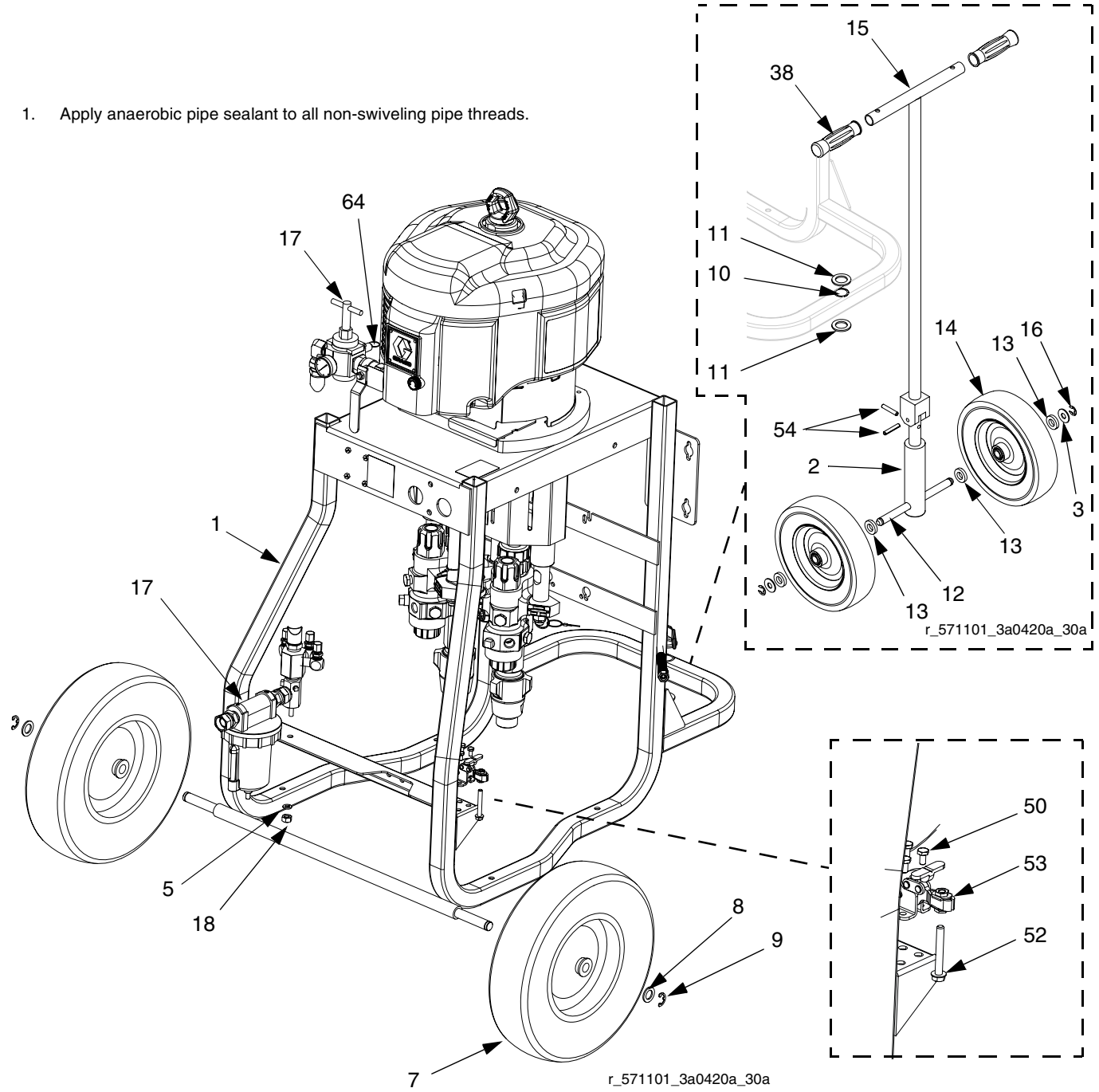

Cart-Mounted System Continued

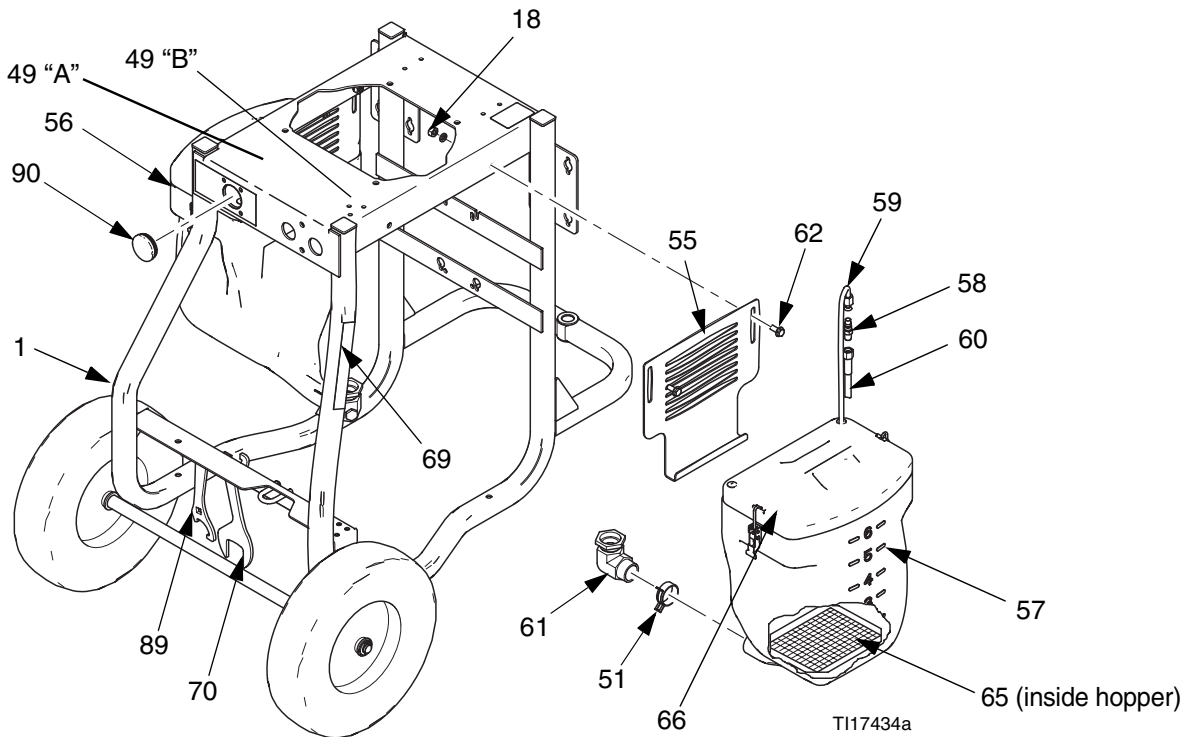
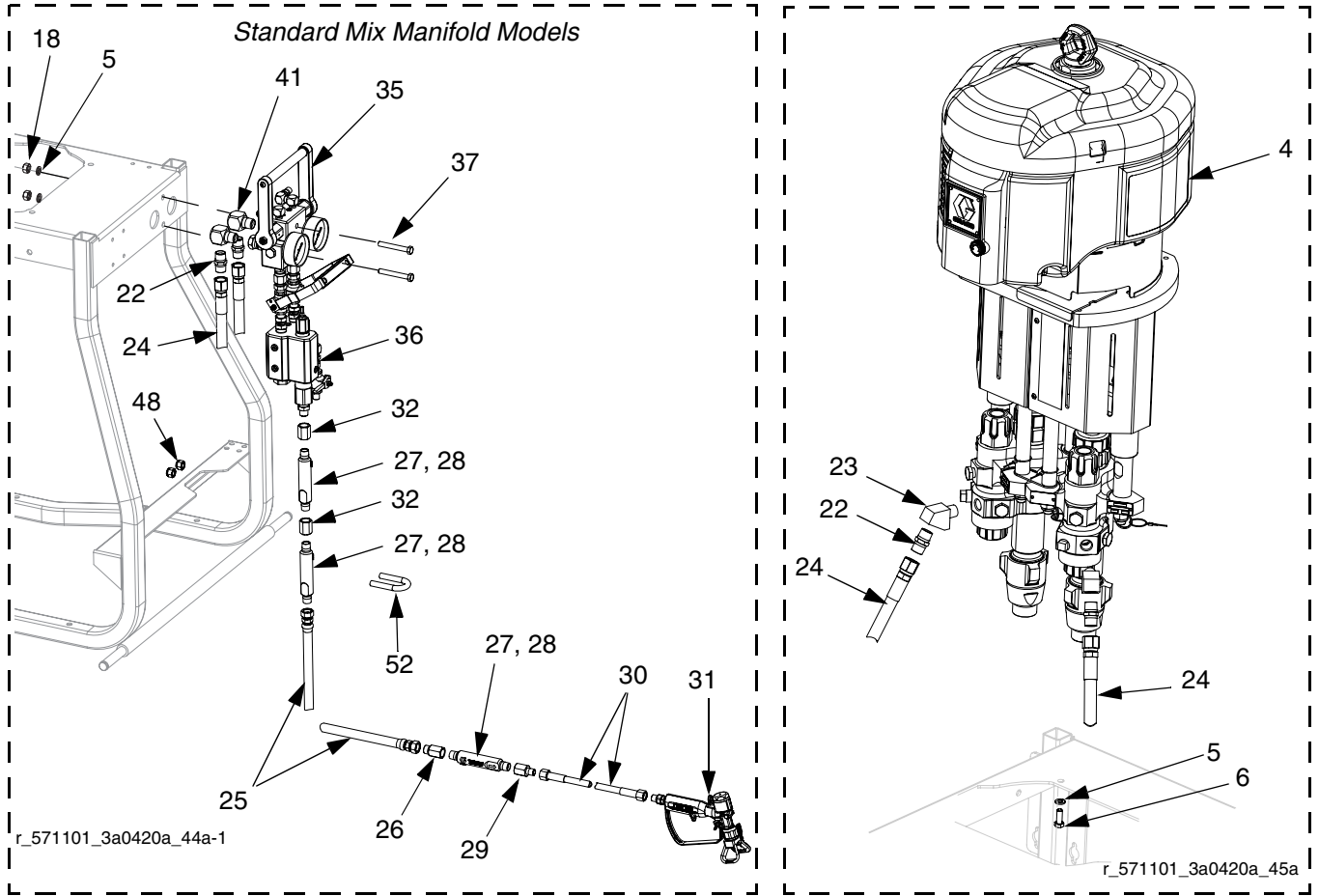

Cart-Mounted System Continued

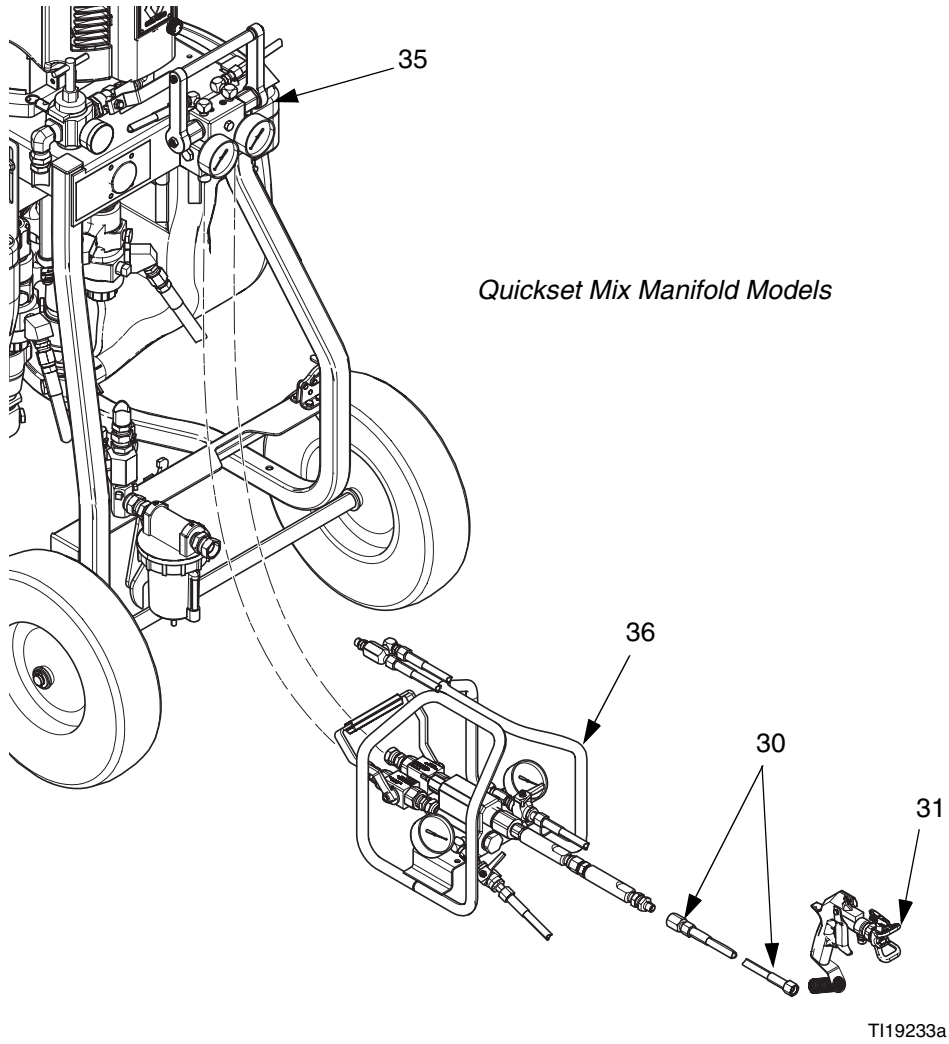

Parts Common to All Systems

Ref	Part	Description	Qty
1	258913	CART, weldment	1
2	262476	AXLE	1
3	111841	WASHER, plain 5/8	2
6	100101	SCREW, cap, hex head	4
7	113362	WHEEL, semi-pneumatic	2
8	154628	WASHER	2
9	113436	RING, retaining	2
10	124410	BEARING, sleeve, 1.00 x 1.25 x 1.5	1
11	124664	WASHER, 1 in. ID, stainless steel	2
12	15A913	AXLE	1
13	191824	WASHER, space	4
14	113807	WHEEL, flat free, urethane	2
15	258982	HANDLE, cart	1
16	101242	RING, retaining, ext.	2
17	258983	MODULE, air controls, inlet	1
19	16F206	LABEL, handles	1
21	111218	CAP, tube, square	4
24	H75003	HOSE, coupled, 7250 psi, 0.50 ID, 3 ft	2
37	106212	SCREW, cap, hex head	2
38	116139	GRIP, handle	2
47	206995	FLUID, TSL, 1 qt.	1
49	15U654	LABEL, identification, A/B	1
50	555357	SCREW	4
53	124259	BRAKE, plunger clamp	1
54	124291	PIN, spring	2
58	116704	ADAPTER, 9/16-18 JIC x 1/4 npt	2
59	15V421	TUBE, recirculation	2
67	16E336	GUIDE, quick start	1
69	16F615	TOOL, wrench, Xtreme	1
70▲	16F359	LABEL, warning, fire and explosion hazard	1
71	16F536	LABEL, arrow	2
89	16G819	TOOL, wrench, Xtreme, filter	1
91	126786	TOOL, wrench, restrictor valve	1

▲ Replacement Danger and Warning labels, tags, and cards are available at no cost.

Parts Varying By Model - XP35 Systems

Ref	Part	Description	Quantity (By System)																					
			262804	281000	281101	281102	281105	281106	281201	281202	281205	281206	281252	281255	281256	281301	281302	281305	281306	281401	281402	281405	281406	
4	281100	PUMP PACKAGE, fixed ratio, 1.0:1			1	1	1	1																
	281200	PUMP PACKAGE, fixed ratio, 2.0:1							1	1	1	1												
	262803	PUMP PACKAGE, fixed ratio, 2.5:1	1										1	1	1									
	281300	PUMP PACKAGE, fixed ratio, 3.0:1														1	1	1	1					
	281400	PUMP PACKAGE, fixed ratio, 4.0:1																			1	1	1	1
	24M422	PUMP PACKAGE, no lowers		1																				
5	100133	WASHER, lock, 3/8	7	7	7	11	7	11	7	11	7	11	11	7	11	7	11	7	11	7	11	7	11	
18	100131	NUT, full hex	3	3	3	7	3	7	3	7	3	7	3	7	3	7	3	7	3	7	3	7	3	
20	512519	MIXER, 1/2-12 element	3	3	3	3			3	3			3			3	3			3	3			
22	158491	FITTING, nipple	4	4	4	4	4	4	4	4	4	4	4	4	4	4	4	4	4	4	4	4	4	
23	15M987	FITTING, elbow, 60 degree	2	2	2	2	2	2	2	2	2	2	2	2	2	2	2	2	2	2	2	2	2	
25	H43825	HOSE, coupled, 4500 psi, 0.375 ID, 25 ft	1	1	1	1			1	1			1			1	1			1	1			
26	15B729	COUPLING	1	1	1	1			1	1			1			1	1			1	1			
27	262478	HOUSING, mixer	3	3	3	3			3	3			3			3	3			3	3			
28	248927	KIT, mixer element, 25 pack	1	1	1	1			1	1			1			1	1			1	1			
29	150287	COUPLING	1	1	1	1			1	1			1			1	1			1	1			
30	H42510	HOSE, coupled, 4500 psi, 0.25 ID, 10 ft	1	1	1	1			1	1			1			1	1			1	1			
31	XTR504	GUN, XTR5	1	1	1	1			1	1			1			1	1			1	1			
32	162024	COUPLING	2	2	2	2			2	2			2			2	2			2	2			
35	262784	MANIFOLD, recirculation, 1/2 valves	1	1	1	1	1	1	1	1	1	1	1	1	1	1	1	1	1	1	1	1	1	
36	262807	MANIFOLD, mix, 1/2 valves	1	1	1	1			1	1			1			1	1			1	1			
41	158683	FITTING, elbow, 90 degree	2	2	2	2	2	2	2	2	2	2	2	2	2	2	2	2	2	2	2	2	2	
48	101566	NUT, lock	2	2	2	2			2	2			2			2	2			2	2			
51	124450	CLAMP, spring, constant-tension				2		2		2		2		2		2		2		2		2		
52	124293	BOLT, u-bolt, 3/8-16, 1.00 dia	1	1	1	1			1	1			1			1	1			1	1			
55	24E872	BRACKET, hopper				2		2		2		2		2		2		2		2		2		
56	262479	HOPPER, blue				1		1		1		1		1		1		1		1		1		
57	262480	HOPPER, green				1		1		1		1		1		1		1		1		1		
60	H52506	HOSE, coupled, 5600 psi, 0.25 ID, 6 ft				2		2		2		2		2		2		2		2		2		
	H52510	HOSE, coupled, 5600 psi, 0.25 ID, 10 ft	2	2	2			2		2			2			2		2		2		2		
61	16D376	FITTING, swivel, 1-1/4, with plug				2		2		2		2		2		2		2		2		2		
62	111192	SCREW, cap flange head				4		4		4		4		4		4		4		4		4		
64	103347	VALVE, safety, 100 psi																			1	1	1	
	113498	VALVE, safety, 110 psi	1	1									1	1	1									
	114055	VALVE, safety, 105 psi			1	1	1	1								1	1	1	1					
	16M190	VALVE, safety, 95 psi							1	1	1	1												
65	262482	STRAINER, hopper, 7 gallon				2		2		2		2		2		2		2		2		2		
66▲	15T468	LABEL, warning				2		2		2		2		2		2		2		2		2		
68	114958	STRAP, tie	10	10	10	10	10	10	10	10	10	10	10	10	10	10	10	10	10	10	10	10	10	
90	16J688	PLUG, hole, gauge	1	1	1	1	1	1	1	1	1	1	1	1	1	1	1	1	1	1	1	1	1	

▲ Replacement Danger and Warning labels, tags, and cards are available at no cost.

Parts Varying By Model - 282xxx (XP50) Systems

Ref	Part	Description	Quantity (By System)																										
			282000	282101	282102	282105	282106	282151	282152	282155	282156	282201	282202	282205	282206	282251	282252	282255	282256	282301	282302	282305	282306	282331	282332	282401	282402	282405	282406
4	282100	PUMP PACKAGE, fixed ratio, 1.0:1		1	1	1	1																						
	282150	PUMP PACKAGE, fixed ratio, 1.5:1						1	1	1	1																		
	282200	PUMP PACKAGE, fixed ratio, 2.0:1									1	1	1	1															
	282250	PUMP PACKAGE, fixed ratio, 2.5:1													1	1	1	1											
	282300	PUMP PACKAGE, fixed ratio, 3.0:1																	1	1	1	1							
	282330	PUMP PACKAGE, fixed ratio, 3.3:1																						1	1				
	282400	PUMP PACKAGE, fixed ratio, 4.0:1																								1	1	1	1
	24M423	PUMP PACKAGE, no lowers	1																										
5	100133	WASHER, lock, 3/8	7	7	11	7	11	7	11	7	11	7	11	7	11	7	11	7	11	7	11	7	11	7	11	7	11	7	11
18	100131	NUT, full hex	3	3	7	3	7	3	7	3	7	3	7	3	7	3	7	3	7	3	7	3	7	3	7	3	7	3	7
20	512519	MIXER, 1/2-12 element	3	3	3			3	3			3	3			3	3			3	3			3	3	3	3		
22	158491	FITTING, nipple	4	4	4	4	4	4	4	4	4	4	4	4	4	4	4	4	4	4	4	4	4	4	4	4	4	4	4
23	15M987	FITTING, elbow, 60 degree	2	2	2	2	2	2	2	2	2	2	2	2	2	2	2	2	2	2	2	2	2	2	2	2	2	2	2
25	H53825	HOSE, coupled, 5600 psi, 0.375 ID, 25 ft	1	1	1			1	1			1	1			1	1			1	1			1	1	1	1		
26	15B729	COUPLING	1	1	1			1	1			1	1			1	1			1	1			1	1	1	1		
27	262478	HOUSING, mixer	3	3	3			3	3			3	3			3	3			3	3			3	3	3	3		
28	248927	KIT, mixer element, 25 pack	1	1	1			1	1			1	1			1	1			1	1			1	1	1	1		
29	150287	COUPLING	1	1	1			1	1			1	1			1	1			1	1			1	1	1	1		
31	XTR504	GUN, XTR5	1	1	1			1	1			1	1			1	1			1	1			1	1	1	1		
32	162024	COUPLING	2	2	2			2	2			2	2			2	2			2	2			2	2	2	2		
35	262783	MANIFOLD, recirculation, 1/2 valves	1	1	1	1	1	1	1	1	1	1	1	1	1	1	1	1	1	1	1	1	1	1	1	1	1	1	1
36	262807	MANIFOLD, mix, 1/2 valves	1	1	1			1	1			1	1			1	1			1	1			1	1	1	1		
41	158683	FITTING, elbow, 90 degree	2	2	2	2	2	2	2	2	2	2	2	2	2	2	2	2	2	2	2	2	2	2	2	2	2	2	2
48	101566	NUT, lock	2	2	2			2	2			2	2			2	2			2	2			2	2	2	2		
51	124450	CLAMP, spring, constant-tension			2			2	2			2	2			2	2			2	2			2	2	2	2		
52	124293	BOLT, u-bolt, 3/8-16, 1.00 dia	1	1	1			1	1			1	1			1	1			1	1			1	1	1	1		
55	24E872	BRACKET, hopper			2			2	2			2	2			2	2			2	2			2	2	2	2		
56	262479	HOPPER, blue			1			1	1			1	1			1	1			1	1			1	1	1	1		
57	262480	HOPPER, green			1			1	1			1	1			1	1			1	1			1	1	1	1		
60	H52506	HOSE, coupled, 5600 psi, 0.25 ID, 6 ft			2			2	2			2	2			2	2			2	2			2	2	2	2		
	H52510	HOSE, coupled, 5600 psi, 0.25 ID, 10 ft	3	3	1	2		3	1	2		3	1	2		3	1	2		3	1	2		3	1	3	1	2	
61	16D376	FITTING, swivel, 1-1/4, with plug			2			2	2			2	2			2	2			2	2			2	2	2	2		
62	111192	SCREW, cap flange head			4			4	4			4	4			4	4			4	4			4	4	4	4		
64	103347	VALVE, safety, 100 psi						1	1	1	1																		
	113498	VALVE, safety, 110 psi	1	1	1	1	1					1	1	1	1					1	1	1	1	1	1	1	1	1	1
	114055	VALVE, safety, 105 psi																											
65	262482	STRAINER, hopper, 7 gallon			2			2	2			2	2			2	2			2	2			2	2	2	2		
66▲	15T468	LABEL, warning			2			2	2			2	2			2	2			2	2			2	2	2	2		
68	114958	STRAP, tie	10	10	10	10	10	10	10	10	10	10	10	10	10	10	10	10	10	10	10	10	10	10	10	10	10	10	10
90	16J688	PLUG, hole, gauge	1	1	1	1	1	1	1	1	1	1	1	1	1	1	1	1	1	1	1	1	1	1	1	1	1	1	1

▲ Replacement Danger and Warning labels, tags, and cards are available at no cost.

Parts Varying By Model - 283xxx (XP50 Quickset) Systems

Ref	Part	Description	Quantity (By System)								
			283101	283102	283201	283202	283301	283302	283401	283402	
4	282100	PUMP PACKAGE, fixed ratio, 1.0:1	1	1							
	282200	PUMP PACKAGE, fixed ratio, 2.0:1			1	1					
	282300	PUMP PACKAGE, fixed ratio, 3.0:1					1	1			
	282400	PUMP PACKAGE, fixed ratio, 4.0:1							1	1	
5	100133	WASHER, lock, 3/8	7	11	7	11	7	11	7	11	
18	100131	NUT, full hex	3	7	3	7	3	7	3	7	
22	158491	FITTING, nipple	4	4	4	4	4	4	4	4	
23	15M987	FITTING, elbow, 60 degree	2	2	2	2	2	2	2	2	
28	248927	KIT, mixer element, 25 pack	1	1	1	1	1	1	1	1	
31	248844	GUN, Flex	1	1	1	1	1	1	1	1	
32	162024	COUPLING	1	1	1	1	1	1	1	1	
35	262783	MANIFOLD, recirculation, 1/2 valves	1	1	1	1	1	1	1	1	
36	24M398	MANIFOLD, Quickset	1	1	1	1	1	1	1	1	
41	158683	FITTING, elbow, 90 degree	2	2	2	2	2	2	2	2	
51	124450	CLAMP, spring, constant-tension		2		2		2		2	
55	24E872	BRACKET, hopper		2		2		2		2	
56	262479	HOPPER, blue		1		1		1		1	
57	262480	HOPPER, green		1		1		1		1	
60	H52506	HOSE, coupled, 5600 psi, 0.25 ID, 6 ft		2		2		2		2	
	H52510	HOSE, coupled, 5600 psi, 0.25 ID, 10 ft	3	1	3	1	3	1	3	1	
61	16D376	FITTING, swivel, 1-1/4, with plug		2		2		2		2	
62	111192	SCREW, cap flange head		4		4		4		4	
64	113498	VALVE, safety, 110 psi	1	1	1	1	1	1	1	1	
65	262482	STRAINER, hopper, 7 gallon		2		2		2		2	
66▲	15T468	LABEL, warning		2		2		2		2	
68	114958	STRAP, tie	10	10	10	10	10	10	10	10	
90	16J688	PLUG, hole, gauge	1	1	1	1	1	1	1	1	

▲ Replacement Danger and Warning labels, tags, and cards are available at no cost.

Parts Varying By Model - XP70 Systems

Ref	Part	Description	Quantity (By System)														
			571000	571101	571102	571151	571152	571201	571202	571251	571252	571301	571302	571401	571402		
4	571100	PUMP PACKAGE, fixed ratio, 1.0:1		1	1												
	571150	PUMP PACKAGE, fixed ratio, 1.5:1				1	1										
	571200	PUMP PACKAGE, fixed ratio, 2.0:1						1	1								
	571250	PUMP PACKAGE, fixed ratio, 2.5:1								1	1						
	571300	PUMP PACKAGE, fixed ratio, 3.0:1										1	1				
	571400	PUMP PACKAGE, fixed ratio, 4.0:1														1	1
	24M423	PUMP PACKAGE, no lowers	1														
5	100133	WASHER, lock, 3/8	7	7	11	7	11	7	11	7	11	7	11	7	11	7	11
18	100131	NUT, full hex	3	3	7	3	7	3	7	3	7	3	7	3	7	3	7
20	512519	MIXER, 1/2-12 element	3	3	3	3	3	3	3	3	3	3	3	3	3	3	3
22	158491	FITTING, nipple	4	4	4	4	4	4	4	4	4	4	4	4	4	4	4
23	15M987	FITTING, elbow, 60 degree	2	2	2	2	2	2	2	2	2	2	2	2	2	2	2
25	H73825	HOSE, coupled, 7250 psi, 0.375 ID, 25 ft	1	1	1	1	1	1	1	1	1	1	1	1	1	1	1
26	15B729	COUPLING	1	1	1	1	1	1	1	1	1	1	1	1	1	1	1
27	262478	HOUSING, mixer	3	3	3	3	3	3	3	3	3	3	3	3	3	3	3
28	248927	KIT, mixer element, 25 pack	1	1	1	1	1	1	1	1	1	1	1	1	1	1	1
29	150287	COUPLING	1	1	1	1	1	1	1	1	1	1	1	1	1	1	1
30	H72510	HOSE, coupled, 7250 psi, 0.25 ID, 10 ft	1	1	1	1	1	1	1	1	1	1	1	1	1	1	1
31	XTR704	GUN, XTR7	1	1	1	1	1	1	1	1	1	1	1	1	1	1	1
32	162024	COUPLING	2	2	2	2	2	2	2	2	2	2	2	2	2	2	2
35	262806	MANIFOLD, recirculation, 1/2 valves	1	1	1	1	1	1	1	1	1	1	1	1	1	1	1
36	262807	MANIFOLD, mix, 1/2 valves	1	1	1	1	1	1	1	1	1	1	1	1	1	1	1
41	158683	FITTING, elbow, 90 degree	2	2	2	2	2	2	2	2	2	2	2	2	2	2	2
48	101566	NUT, lock	2	2	2	2	2	2	2	2	2	2	2	2	2	2	2
51	124450	CLAMP, spring, constant-tension			2		2		2		2		2		2		2
52	124293	BOLT, u-bolt, 3/8-16, 1.00 dia	1	1	1	1	1	1	1	1	1	1	1	1	1	1	1
55	24E872	BRACKET, hopper			2		2		2		2		2		2		2
56	262479	HOPPER, blue			1		1		1		1		1		1		1
57	262480	HOPPER, green			1		1		1		1		1		1		1
60	H52506	HOSE, coupled, 5600 psi, 0.25 ID, 6 ft			2		2		2		2		2		2		2
	H52510	HOSE, coupled, 5600 psi, 0.25 ID, 10 ft	2	2		2		2		2		2		2		2	
61	16D376	FITTING, swivel, 1-1/4, with plug			2		2		2		2		2		2		2
62	111192	SCREW, cap flange head			4		4		4		4		4		4		4
64	113498	VALVE, safety, 110 psi	1	1	1			1	1	1	1	1	1	1	1	1	1
	116643	VALVE, safety, relief, air, 90 psi				1	1										
65	262482	STRAINER, hopper, 7 gallon			2		2		2		2		2		2		2
66▲	15T468	LABEL, warning			2		2		2		2		2		2		2
68	114958	STRAP, tie	10	10	10	10	10	10	10	10	10	10	10	10	10	10	10
90	16J688	PLUG, hole, gauge	1	1	1	1	1	1	1	1	1	1	1	1	1	1	1

▲ Replacement Danger and Warning labels, tags, and cards are available at no cost.

Bare Proportioning Pump Package

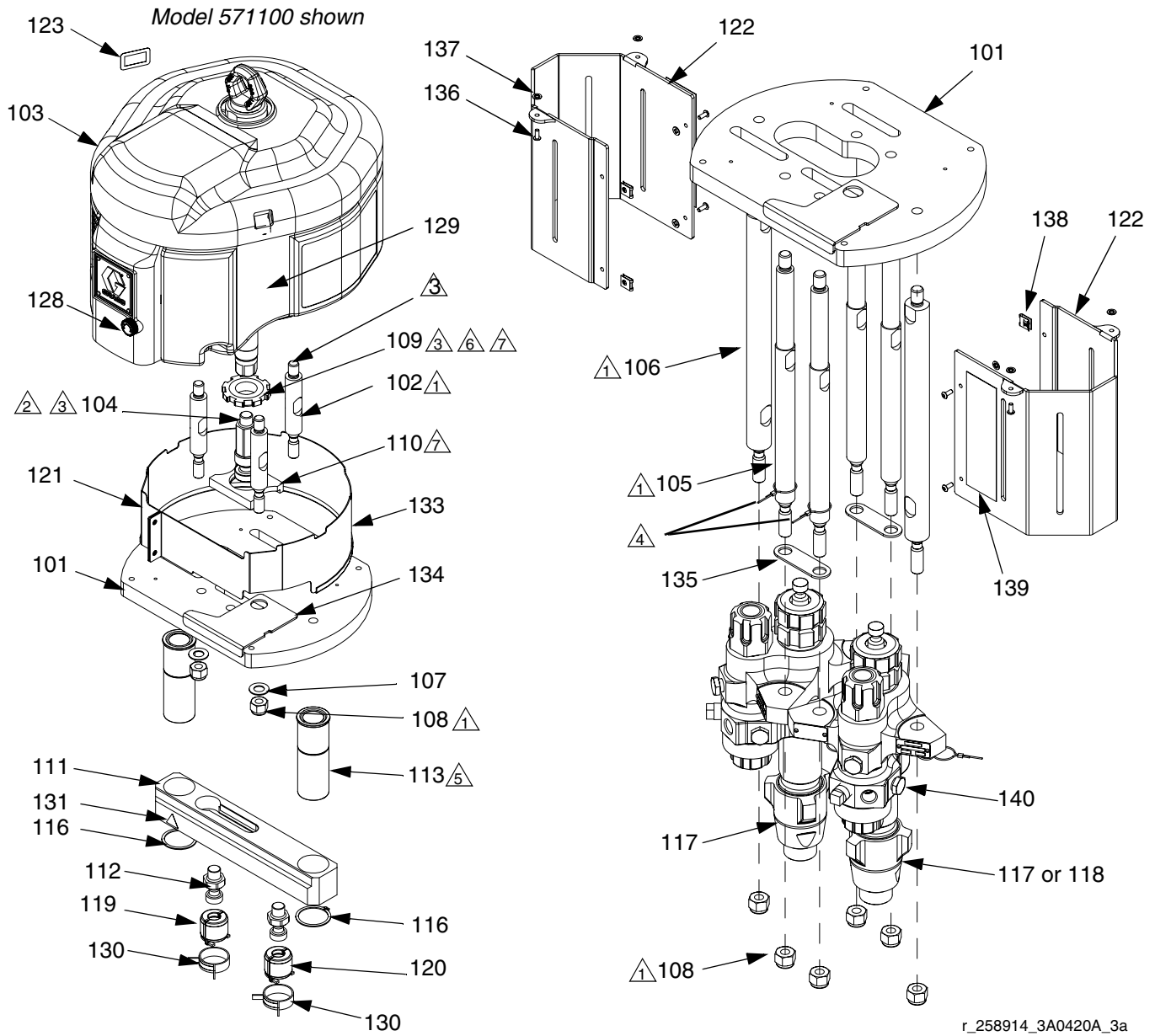

r_258914_3A0420A_2a

r_258914_3A0420A_3a

- ⚠ Torque together to 50-60 ft-lb (68-81 N•m).
- ⚠ Torque to 145-155 ft-lb (196-210 N•m).
- ⚠ Apply blue thread sealant.
- ⚠ Insert lanyard from locking pin onto pumps (17, 18) as shown.
- ⚠ Do not apply lubricant.
- ⚠ Torque to 70-80 ft-lb (95-108 N•m).
- ⚠ Apply lithium grease to mating tapered surfaces.

Air Controls, 258983

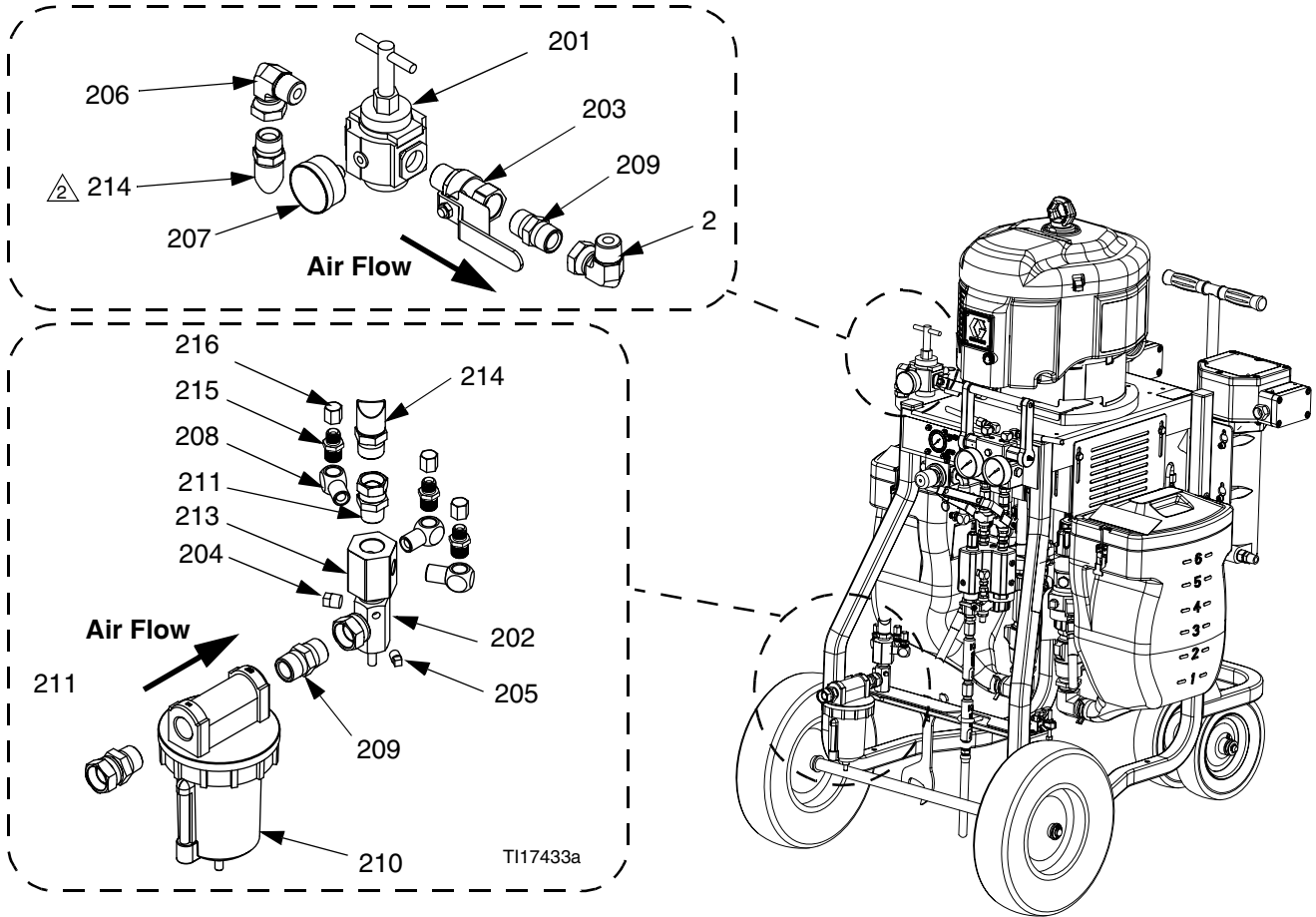

1. Apply anaerobic pipe sealant to all non-swiveling pipe threads.

⚠ Connect hose (214) to fitting (206) and air distribution manifold (213).

r_571100_3A0420A_1a-1

Ref. No.	Part No.	Description	Qty	Ref. No.	Part No.	Description	Qty
201	16F014	REGULATOR, air, T-handle	1	211	157785	FITTING, union; 3/4 male x female	2
202	207675	MANIFOLD, air	1	213	15E145	MANIFOLD, air distribution	1
203	113218	VALVE, ball	1	214	16E004	HOSE, coupled, air; 26 in. (660 mm)	1
204	100509	PLUG; 1/4 npt	1	215	157350	NIPPLE; 3/8 x 1/4 npt	3
205	100403	PLUG; 1/8 npt	1	216	115781	CAP PLUG; 1/4 npt	3
206	160327	FITTING, union, 90°; 3/4 male x female	2				
207	101689	GAUGE, pressure, air	1				
208	155699	FITTING, elbow, street; 3/8 npt	3				
209	119992	FITTING, pipe, nipple, 3/4 x 3/4 npt	2				
210	117628	FITLTER, air, auto drain; 3/4 npt	1				
210a*	106204	ELEMENT, filter; 3/4 npt	1				

* Not shown.

Fluid Circulation Manifold with Over Pressure Relief Valve

Assembly 262784 (XP35); 262783 (XP50); 262806 (XP70)

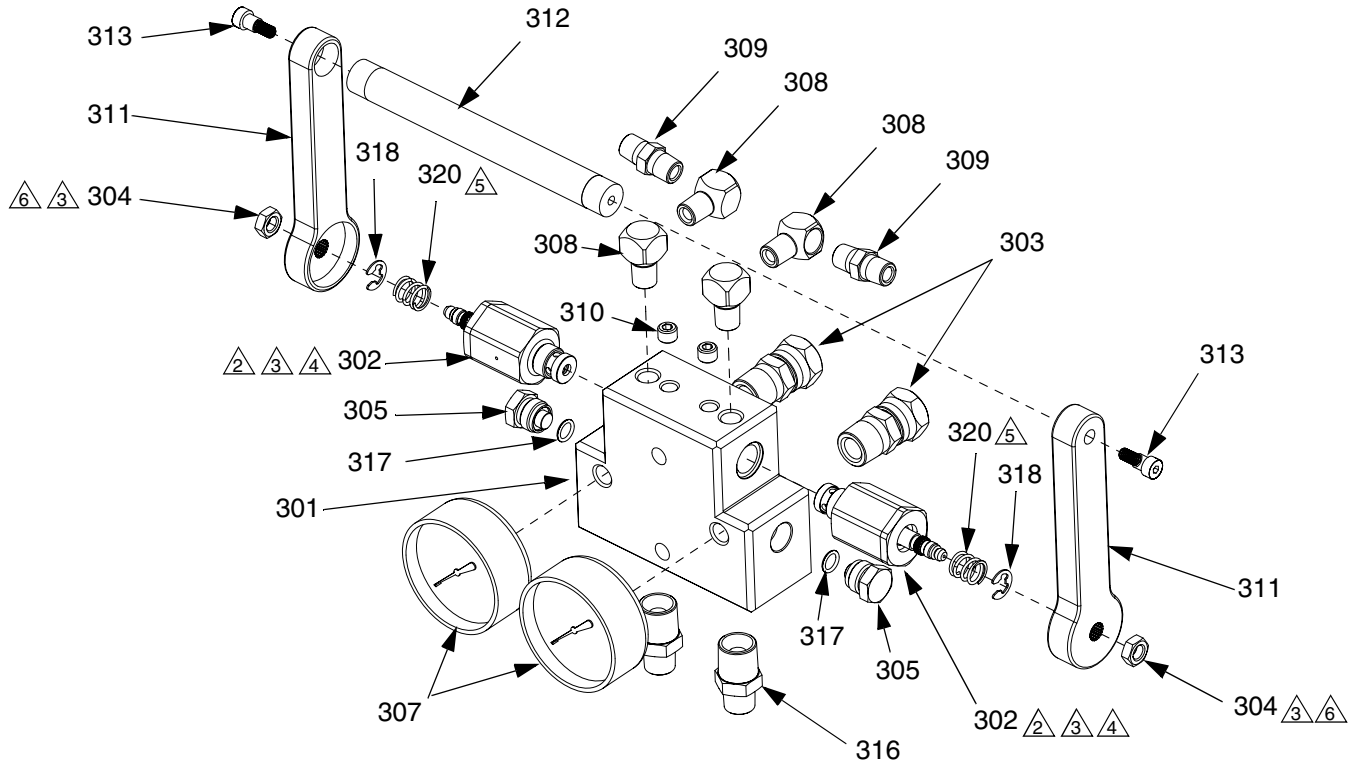

r_258988_3a0420a_1c

1. Apply anaerobic pipe sealant to all non-swiveling pipe threads.

△₂ Torque to 28-32 ft-lb (38-43 N•m).

△₃ Apply blue anaerobic adhesive to threads.

△₄ Further tighten either valve (302) as required to line up handle straight across.

△₅ Apply grease to spring ends.

△₆ Torque to 70-90 in-lb (7.9-9 N•m).

Ref	Part	Description	Qty	Ref	Part	Description	Qty
301	16D693	BLOCK, manifold, recirculation	1	316	156684	FITTING, nipple, 1/2 npt x 1/2 npt	2
302†	262520	VALVE, over pressure relief, silver, XP70	2	317	121399	O-RING, solvent resistant	2
◆	262809	VALVE, over pressure relief, gold, XP50	2	318	124676	RING, snap, external	2
★	262808	VALVE, over pressure relief, purple, XP35	2	320	150829	SPRING, compression	2
303	156684	UNION; 1/2 in. male x female	2	351*	159239	FITTING, nipple, pipe, reducing	2
304	112309	NUT, hex, jam	2	352*	156173	UNION, swivel	2
305	198241	PLUG, port, pressure; 11/16-24	2	* Not shown. Shipped loose.			
307†◆	114434	GAUGE, pressure, fluid, sst; 10k psi	2	★ For XP35 systems only.			
★	113654	GAUGE, pressure, fluid, sst; 5k psi	2	◆ For XP50 systems only.			
308	100840	FITTING, elbow, street; 1/4 npt	4	† For XP70 systems only.			
309	156971	FITTING, nipple; 1/4 npt x npsm	2	NOTE: Loose fittings are supplied with replacement manifold to also fit Series A XP Proportioners with 3/8 in. mix manifold ball valves.			
310	557349	PLUG, dry seal 1/8 npt	2				
311	16E334	HANDLE, manifold	2				
312	16E332	ROD, connecting, handle	1				
313	124859	SCREW, button head	2				

Recommended Spare Parts

Keep these spare parts on hand to reduce downtime.

Pump Repair Kits

See page 13 to see what pumps are used on your system. See lower manual for repair kits.

Pump Filter O-rings (packs of 10)

262483, Top o-ring
244895, Middle o-ring
262484, Bottom o-ring

Recirculation/Overpressure valve (see page 39)

XP35: 262808, purple
(also for use with XP-h 284x01 assemblies)
XP50: 262809, gold
(also for use with XP-h 284x02 assemblies)
XP70: 262520, silver
(also for use with XP-h 284x03 assemblies)

15K692, Seal Mix Manifold Check Valve Cartridge

NOTE: 15K692 must be replaced when cleaning the check valves.

1/2 in. Mix Manifold Inlet Ball Valves

24M601, Ball valve repair kit
262740, Spare valve (no handle)
262739, Spare valve (single handle)

248927, Spare Mix Elements (pack of 25)

1/2 in. OD x 12 element, acetal plastic

248837, XTR Spray Gun Repair Kit

XHD010, Seat/Seal Kit for XHD RAC Tips (5 pack)

XHDxxx, spray tips

See spray gun manual for tips.

Accessories and Kits

Acceptable For Use in Explosive Atmospheres

Blue 7 Gallon Hopper Kit, 24F376 Green 7 Gallon Hopper Kit, 24F377

Mount to the sides of the XP system. See manual 406860 for more information.

Solvent Pump Kit, 262393

For supplying solvent to the mix manifold. See manual 310863 for more information.

Desiccant Dryer Kit, 262454

For use with polyurethane isocyanates in 7 gallon hoppers. See manual 406739 for more information.

Desiccant Dryer Filter 2 Pack, 24K984

Heater Adapter Kit, 262450

Hose and fittings for connecting Viscon HP heaters to XP system. See manual 406861 for parts. Purchase heaters separately, see heater manual for part numbers.

Twistork Agitator Kit, 256274

For mixing viscous materials held within a 55 gallon drum. See manual 312769 for more information.

5:1 Feed Pump Kit, 256276

For supplying viscous materials from a drum to XP system. See manual 312769 for more information.

5:1 Drum Feed Kit, 256255

One 5:1 pump feed kit and one Twistork agitator kit for mixing and supplying viscous materials from a 55 gallon drum to XP system. See manual 312769 for more information.

10:1 Drum Feed Kit, 256433

For supplying highly viscous material from a 55 gallon drum to XP system. See manual 312769 for more information.

20 Gallon Hopper Kit, 255963

Floor Stand for 20 Gal. Hopper, 262824

1-1/2 in. ID Hose Flex Feed Kit, 262820

XP Wall Mount Bracket, 262812

Works with air or hydraulic XP systems.

Leg Stand, 24M281

Includes wall bracket 262812.

1/2 in. Ball Valve Upgrade Kit for Mix Manifold, 24M593

Quickset Mix Manifold, 24M398

Mix manifold with independent A and B flushing for use with quick hardening materials. See mix manifold manual 3A0590 for more information.

Remote Mix Manifold Carriage, 262522

A protective guard to mount mix manifold remote. See mix manifold manual 3A0590 for more information.

Mix Manifold Restrictor Wrench, 126786

Gun Splitter with Carriage, 262826

One splitter valve to use one, two, or three spray guns with the system. Provides independent flush for two guns. Optional 3rd gun port does not have independent flush. See manual 3A2573 for more information.

DataTrak™ Conversion Kit, NXT606

Intrinsically safe battery operated NXT air motor accessory for material tracking system diagnostics and run-away control. See manual 311486 for more information.

Not Approved For Explosive Atmospheres

These kits do not carry the EX mark.

2:1 Feed Pump Kit, 256275

For supplying viscous materials from a drum to XP system. See manual 312769 for more information.

2:1 Drum Feed Kit, 256232

One T2 pump feed kit and one Twistork agitator kit for mixing and supplying viscous materials from a 55 gallon drum to XP system. See manual 312769 for more information.

Wall Powered Pressure Monitor Kit, 262940

Air Powered Pressure Monitor Kit, 262942

Automatically monitors difference between A and B pressures when at spray pressure and shuts down the system if there is a problem.

Technical Data

XP Proportioners		
	U.S.	Metric
Maximum Fluid Working Pressure	See Models section beginning on page 11.	
Maximum Air/Hydraulic Oil Working Pressure	See Models section beginning on page 11.	
Combined Fluid Output (cc/cycle)	See Models section beginning on page 11.	
Pressure Ratio	See Models section beginning on page 11.	
Fluid Flow at 40 cpm	See Models section beginning on page 11.	
Hydraulic Fluid Consumption (XP-h models only)	0.2 gallons per cycle	0.76 liters per cycle
Air inlet size	3/4 npsm(f)	
Maximum air pressure supply to the system	175 psi	12 bar, 1 MPa
Fluid pump inlets without hoppers	1-1/4 in. npsm(m)	
Fluid gauge manifold outlets	1/2 in. npt(f)	
Fluid mix manifold inlets	1/2 in. npt(f) ball valves	
Mix manifold material outlet	1/2 in. npt(f)	
Maximum feed pressure from remote source	250 psi	17 bar, 1.7 MPa
Sound pressure	86 dBA at 100 psi (7 bar, 0.7 MPa)	
Sound power	98 dBA at 100 psi (7 bar, 0.7 MPa)	
Maximum Storage Time	5 years (To maintain original performance, replace soft seals after 5 years of inactivity.)	
Maximum Lifetime	Indefinite with recommended maintenance and periodic rebuilds for critical parts.	
Power Efficiency Factor (XP70)	75 cu. ft compressed air/1 gallon sprayed material at 100 psi 2.12 m ³ compressed air/1 liter sprayed material at 7 bar (0.7 MPa)	
Air consumption per 1 gallon (3.78 l) of flow		
XP70	75 scfm at 100 psi/gpm (2.12 m ³ /min at 7 bar, 0.7 MPa)	
XP50	60 scfm at 100 psi/gpm (1.7 m ³ /min at 7 bar, 0.7 MPa)	
XP35	50 scfm at 100 psi/gpm (1.42 m ³ /min at 7 bar, 0.7 MPa)	
Filtration:		
Air inlet filtration	40-micron filter/separator included	
XP pump outlets	30 mesh	
XTR Spray Gun	60 mesh	
Fluid Viscosity Range:		
Gravity feed with 7 gallon (26 liter) hoppers	200 to 20,000 cps (pourable)	
Pressure feed	Any viscosity that will not require feed pressure more than 15% of outlet pressure	
Environmental Rating (Indoor/outdoor)		
Hazardous Areas	EX II 2 G c IIA T2 NOTE: XP-h pump packages (284xxx) are not Ex rated.	
Ambient Temperature Range:		
Operating	40-130°F	4-54°C
Storage	30-160°F	-1-71°C
Maximum Fluid Temperature	160°F	71°C
Wetted materials:		
Housings and manifolds	Carbon steel with electroless nickel plating	
Miscellaneous parts	Plated carbon steel, stainless steels, carbide, acetal, UHM-WPE, nylon, PTFE solvent resistant plastics	
Pump packings	Carbon filled PTFE, proprietary UHMWPE	
Flush pump suction tube	Aluminum	
Hoses	Nylon core	

Weight:		
Full XP35, XP50, or XP70 System with heaters, solvent flush pump, and hoppers	575 lb	261 kg
Bare XP35, XP50, or XP70 system with no heaters, solvent flush pump, or hoppers	425 lb	193 kg
XP35, XP50, or XP70 Pump only	286 lb	130 kg
XP-h System	290 lb	132 kg

Dimensions

Top View

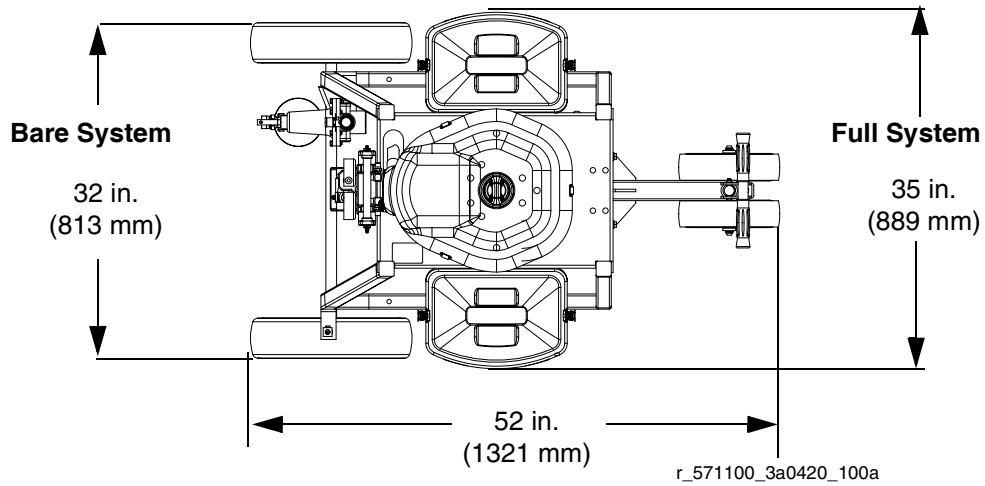

Side View

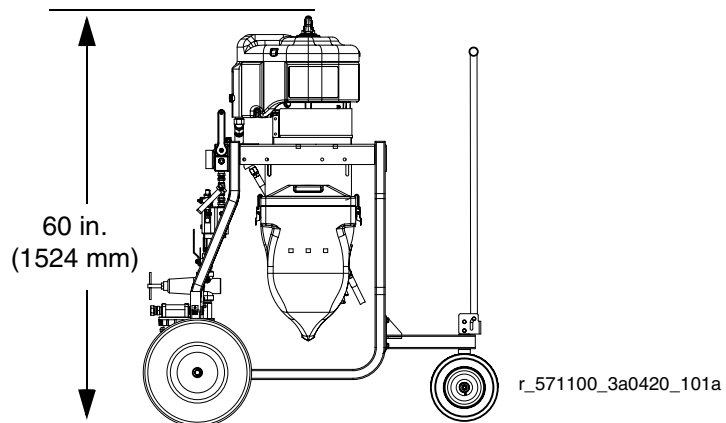

Floor Mounting Dimensions, Top View

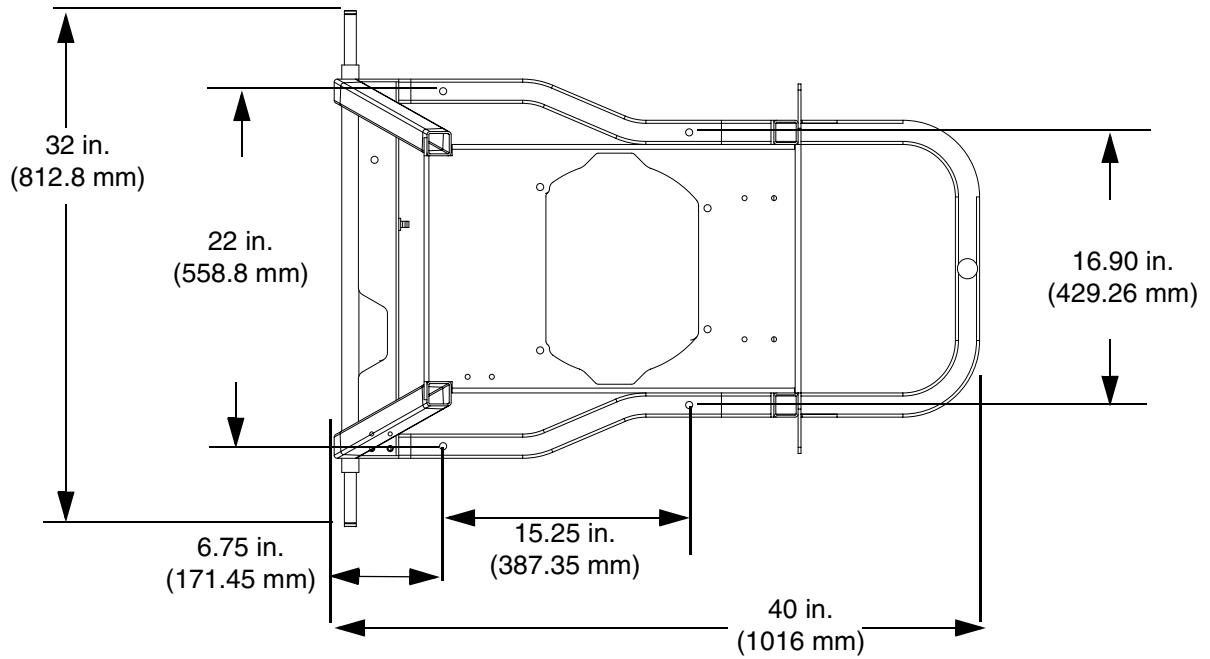

Bare Proportioner Mounting Hole Dimensions

The dimensions below is the minimum opening size for mounting a bare proportioner.

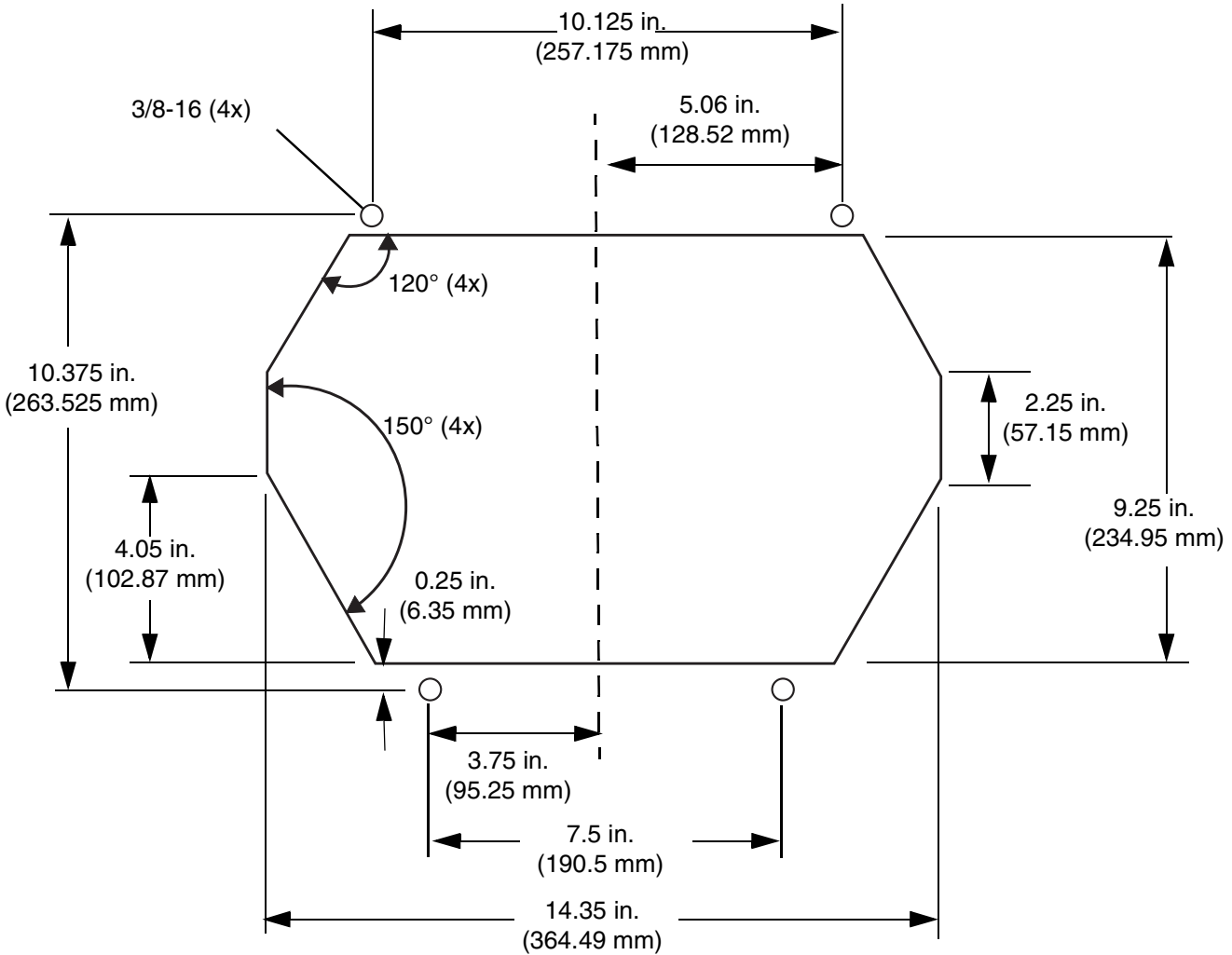

Wall Mount Bracket 262812 Dimensions

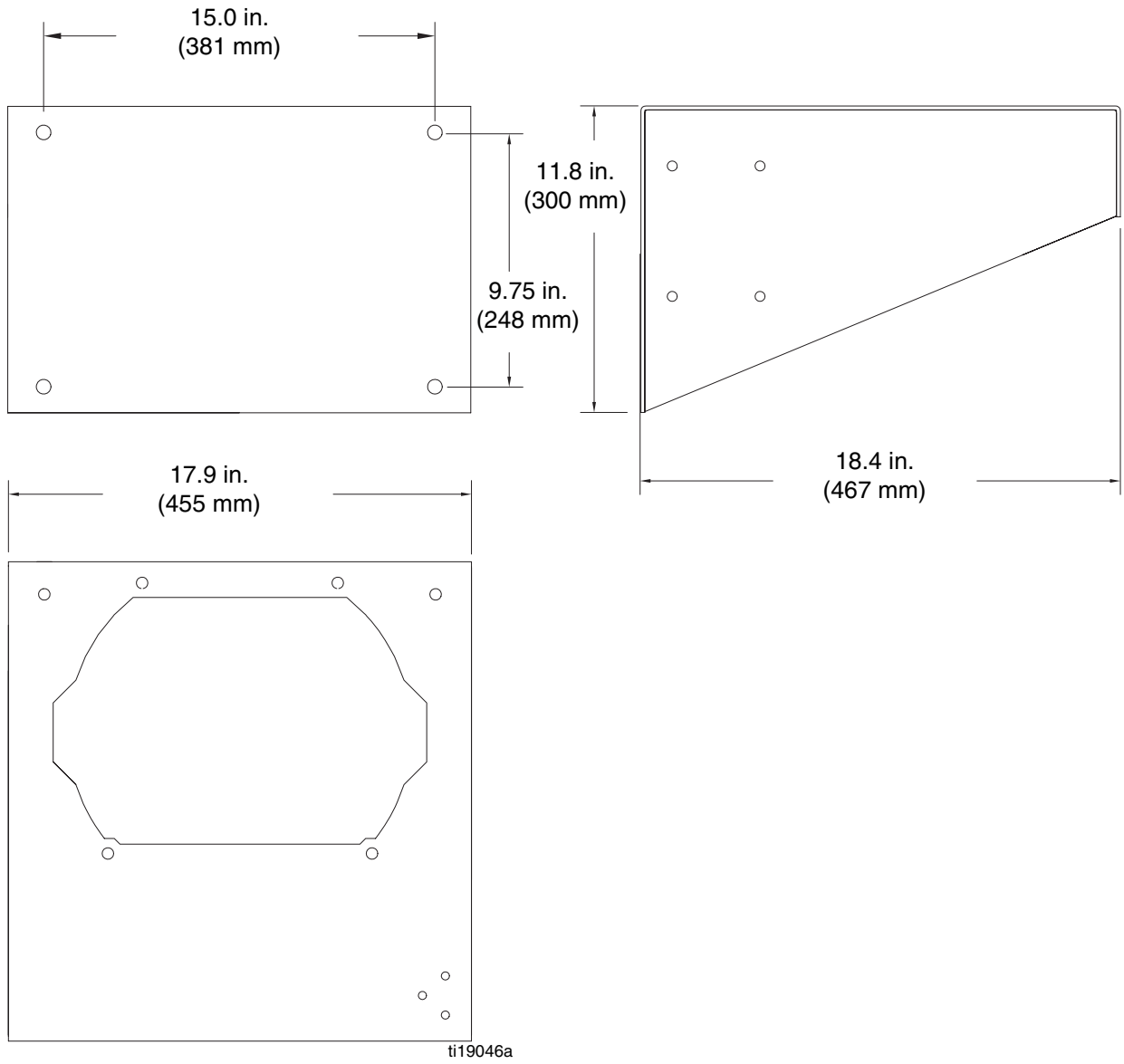

Floor Stand 24M281 Dimensions

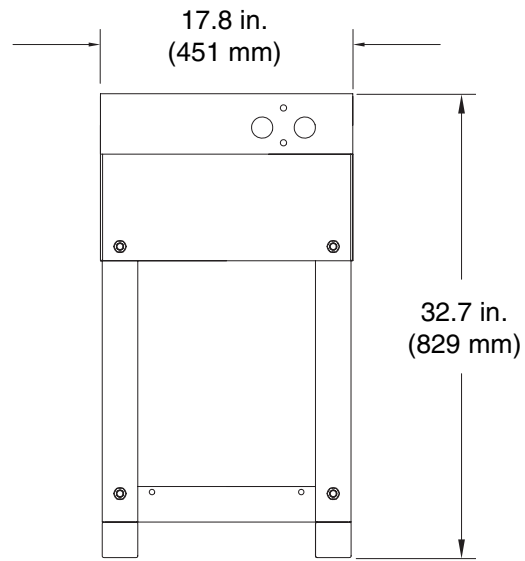
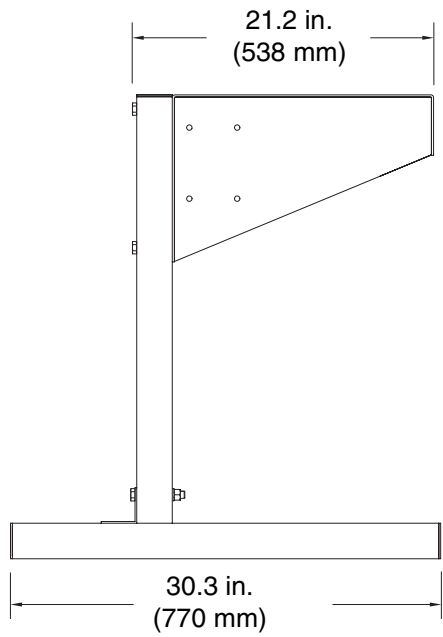

ti19047a

Hydraulic Unit Dimensions

Shown installed on floor stand

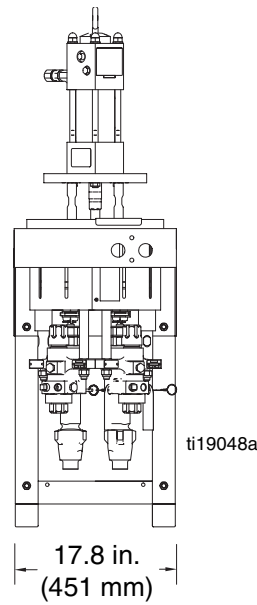
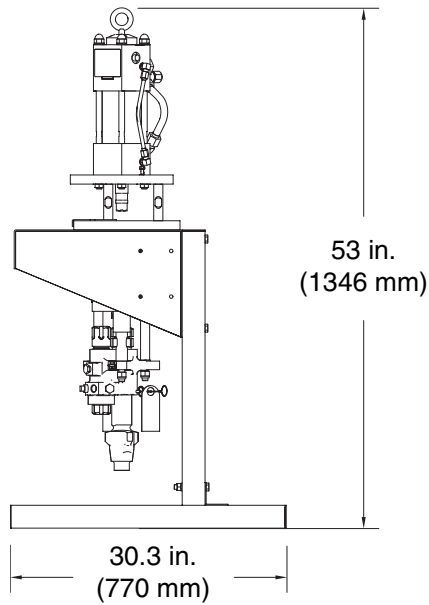

ti19048a

Graco Standard Warranty

Graco warrants all equipment referenced in this document which is manufactured by Graco and bearing its name to be free from defects in material and workmanship on the date of sale to the original purchaser for use. With the exception of any special, extended, or limited warranty published by Graco, Graco will, for a period of twelve months from the date of sale, repair or replace any part of the equipment determined by Graco to be defective. This warranty applies only when the equipment is installed, operated and maintained in accordance with Graco's written recommendations.

This warranty does not cover, and Graco shall not be liable for general wear and tear, or any malfunction, damage or wear caused by faulty installation, misapplication, abrasion, corrosion, inadequate or improper maintenance, negligence, accident, tampering, or substitution of non-Graco component parts. Nor shall Graco be liable for malfunction, damage or wear caused by the incompatibility of Graco equipment with structures, accessories, equipment or materials not supplied by Graco, or the improper design, manufacture, installation, operation or maintenance of structures, accessories, equipment or materials not supplied by Graco.

This warranty is conditioned upon the prepaid return of the equipment claimed to be defective to an authorized Graco distributor for verification of the claimed defect. If the claimed defect is verified, Graco will repair or replace free of charge any defective parts. The equipment will be returned to the original purchaser transportation prepaid. If inspection of the equipment does not disclose any defect in material or workmanship, repairs will be made at a reasonable charge, which charges may include the costs of parts, labor, and transportation.

THIS WARRANTY IS EXCLUSIVE, AND IS IN LIEU OF ANY OTHER WARRANTIES, EXPRESS OR IMPLIED, INCLUDING BUT NOT LIMITED TO WARRANTY OF MERCHANTABILITY OR WARRANTY OF FITNESS FOR A PARTICULAR PURPOSE.

Graco's sole obligation and buyer's sole remedy for any breach of warranty shall be as set forth above. The buyer agrees that no other remedy (including, but not limited to, incidental or consequential damages for lost profits, lost sales, injury to person or property, or any other incidental or consequential loss) shall be available. Any action for breach of warranty must be brought within two (2) years of the date of sale.

GRACO MAKES NO WARRANTY, AND DISCLAIMS ALL IMPLIED WARRANTIES OF MERCHANTABILITY AND FITNESS FOR A PARTICULAR PURPOSE, IN CONNECTION WITH ACCESSORIES, EQUIPMENT, MATERIALS OR COMPONENTS SOLD BUT NOT MANUFACTURED BY GRACO. These items sold, but not manufactured by Graco (such as electric motors, switches, hose, etc.), are subject to the warranty, if any, of their manufacturer. Graco will provide purchaser with reasonable assistance in making any claim for breach of these warranties.

In no event will Graco be liable for indirect, incidental, special or consequential damages resulting from Graco supplying equipment hereunder, or the furnishing, performance, or use of any products or other goods sold hereto, whether due to a breach of contract, breach of warranty, the negligence of Graco, or otherwise.

FOR GRACO CANADA CUSTOMERS

The Parties acknowledge that they have required that the present document, as well as all documents, notices and legal proceedings entered into, given or instituted pursuant hereto or relating directly or indirectly hereto, be drawn up in English. Les parties reconnaissent avoir convenu que la rédaction du présente document sera en Anglais, ainsi que tous documents, avis et procédures judiciaires exécutés, donnés ou intentés, à la suite de ou en rapport, directement ou indirectement, avec les procédures concernées.

Graco Information

For the latest information about Graco products, visit www.graco.com.

TO PLACE AN ORDER, contact your Graco distributor or call to identify the nearest distributor.

Phone: 612-623-6921 **or Toll Free:** 1-800-328-0211 **Fax:** 612-378-3505

All written and visual data contained in this document reflects the latest product information available at the time of publication. Graco reserves the right to make changes at any time without notice.

For patent information, see www.graco.com/patents.

Original instructions. This manual contains English. MM 3A0420

Graco Headquarters: Minneapolis
International Offices: Belgium, China, Japan, Korea

GRACO INC. AND SUBSIDIARIES • P.O. BOX 1441 • MINNEAPOLIS MN 55440-1441 • USA

Copyright 2010, Graco Inc. All Graco manufacturing locations are registered to ISO 9001.

www.graco.com

Revision T, April 2014