

Displacement Pump

332922A

EN

For professional use only.

3300 psi (22.7 MPa, 227 bar) Maximum Working Pressure

Model 16X414, Series A

UltraMax II and Ultimate MX II 695/795
GMAX II 3900

Model 16X418, Series A

TexSpray Mark IV

Model 16X419, Series A

UltraMax II and Ultimate MX II 1095/1595
GMAX II 5900

Model 16X420, Series A

UltraMax II and Ultimate MX II 1095/1595 IronMan
GMAX 5900 IronMan

Model 16X421, Series A

TexSpray Mark V and 5900 HD

Model 16Y602, Series A

TexSpray Mark VII

Model 16X426, Series A

GMAX II 7900

Model 16X427, Series A

TexSpray Mark X and 7900HD

Model 16Y599, Series A

TexSpray Mark V and IronMan



Important Safety Instructions

Read all warnings and instructions in this manual. Save these instructions.

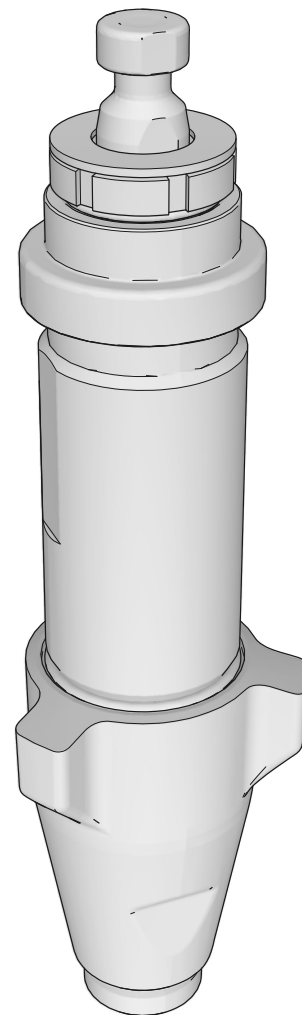









ti23273a

Table of Contents

Warnings	2	Parts - Pump 16X426, 16X427	13
Service	3	Technical Data	14
Parts - Pump 16X414, 16X418	11	Notes	15
Parts - Pump 16X419, 16X420, 16X421, 16Y599, 16Y602	12	Graco Standard Warranty	16

Warnings

The following warnings are for the setup, use, grounding, maintenance, and repair of this equipment. The exclamation point symbol alerts you to a general warning and the hazard symbols refer to procedure-specific risks. When these symbols appear in the body of this manual or on warning labels, refer back to these Warnings. Product-specific hazard symbols and warnings not covered in this section may appear throughout the body of this manual where applicable.

 WARNING	
 	<p>EQUIPMENT MISUSE HAZARD</p> <p>Misuse can cause death or serious injury.</p> <ul style="list-style-type: none"> Do not exceed the maximum working pressure or temperature rating of the lowest rated system component. See Technical Data in all equipment manuals. Use fluids and solvents that are compatible with equipment wetted parts. See Technical Data in all equipment manuals. Read fluid and solvent manufacturer’s warnings. For complete information about your material, request MSDS from distributor or retailer. Turn off all equipment and follow the Pressure Relief Procedure when equipment is not in use. Check equipment daily. Repair or replace worn or damaged parts immediately with genuine manufacturer’s replacement parts only. Do not alter or modify equipment. Alterations or modifications may void agency approvals and create safety hazards. Use equipment only for its intended purpose. Call your distributor for information. Do not use 1,1,1-trichloroethane, methylene chloride, other halogenated hydrocarbon solvents or fluids containing such solvents. Comply with all applicable safety regulations.
 	<p>MOVING PARTS HAZARD</p> <p>Moving parts can pinch, cut or amputate fingers and other body parts.</p> <ul style="list-style-type: none"> Keep clear of moving parts. Do not operate equipment with protective guards or covers removed. Pressurized equipment can start without warning. Before checking, moving, or servicing equipment, follow the Pressure Relief Procedure and disconnect all power sources.
  	<p>SKIN INJECTION HAZARD</p> <p>High-pressure spray is able to inject toxins into the body and cause serious bodily injury. In the event that injection occurs, get immediate surgical treatment.</p> <ul style="list-style-type: none"> Do not aim the gun at, or spray any person or animal. Keep hands and other body parts away from the discharge. For example, do not try to stop leaks with any part of the body. Always use the nozzle tip guard. Do not spray without nozzle tip guard in place. Do not leave the unit energized or under pressure while unattended. When the unit is not in use, turn off the unit and follow the Pressure Relief Procedure for turning off the unit. Always engage the trigger lock when not spraying. Verify the trigger lock is functioning properly.

Service

Pressure Relief Procedure



Follow the Pressure Relief Procedure whenever you see this symbol.



This equipment stays pressurized until pressure is manually relieved. To help prevent serious injury from pressurized fluid, such as skin injection, splashing fluid and moving parts, follow the Pressure Relief Procedure when you stop spraying and before cleaning, checking, or servicing the equipment.

1. Engage trigger lock.
2. Turn ON/OFF switch to OFF.
3. Unplug power cord.
4. Disengage trigger lock. Hold metal part of gun against grounded metal pail and trigger gun into pail to relieve pressure.
5. Engage the trigger lock.
6. Open all fluid drain valves in the system, having a waste container ready to catch drainage. Leave drain valve(s) open until you are ready to spray again.
7. If you suspect the spray tip or hose is clogged or that pressure has not been fully relieved after following the steps above, VERY SLOWLY loosen tip guard retaining nut or hose end coupling to relieve pressure gradually, then loosen completely. Clear hose or tip obstruction.

Pump Repair Kits

Pump	Repair Kit
16X414	248212
16X419, 16X420	248213 (stainless steel check balls) 16X430 (ceramic check balls)
16X426	249123 (stainless steel check balls) 17A578 (ceramic check balls)
16X427	16X431
16X418	24V063
16X421, 16Y599	249189
16Y602	24M830

Tools Needed

- Vise
- 12 in. adjustable, open-end wrench (2)
- Hammer (20 oz maximum)
- Small screwdriver
- Throat Seal Liquid
- Pick or long small screwdriver

Cleaning and Inspecting Parts

Clean and inspect parts. Pay particular attention to the ball seats in the intake valve and piston, which must have no nicks or wear, and to the inside of the sleeve and the outside of the piston rod, which must not be worn or scratched. Replace worn or damaged parts.

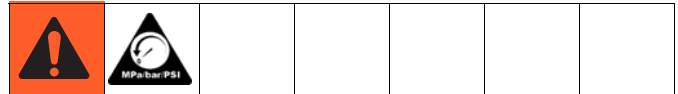

COMPONENT RUPTURE HAZARD

To reduce the risk of serious injury from pressurized fluid, never use sharp or pointed tools to remove sleeve. If the sleeve cannot be removed easily, return the sleeve and cylinder to a Graco distributor for removal.

NOTE: Remove and clean sleeve when repacking pump.

Repair When Pump is Separated From Sprayer

Disassembling the Pump

1. Remove packing nut (202) and o-ring (228).

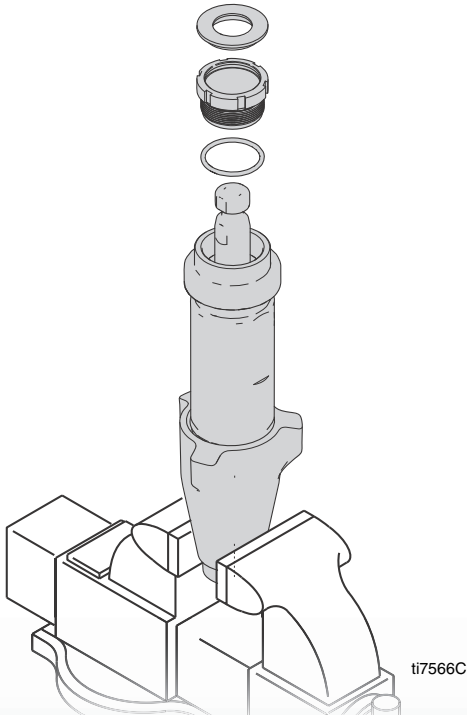

2. Unscrew intake valve from cylinder.

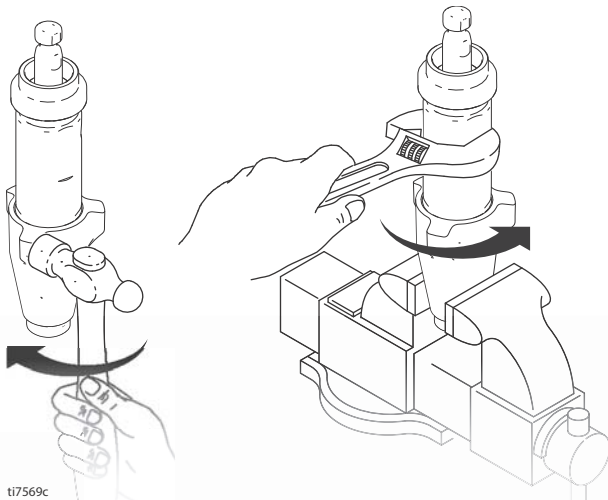

3. Disassemble intake valve. Clean and inspect o-ring (227). **NOTE:** A pick may be required to remove o-ring.

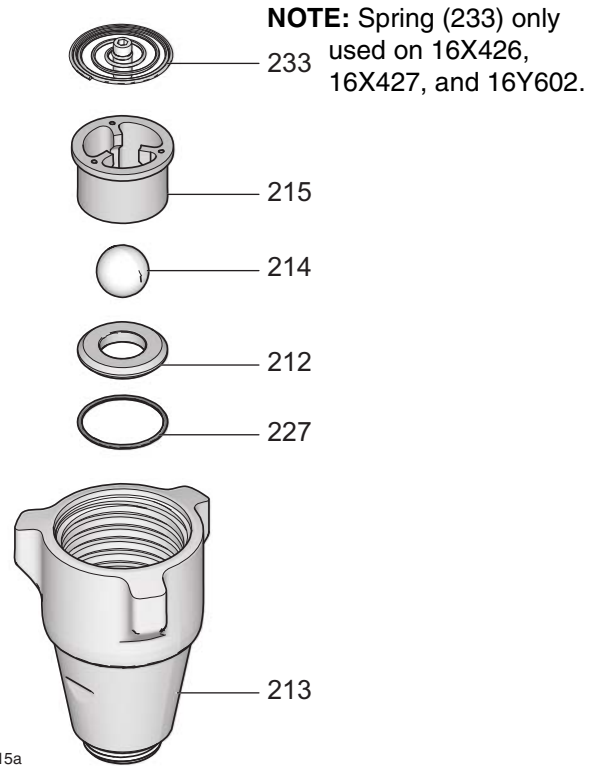

4. Tap piston rod out of cylinder with a hammer or flip over and tap piston rod out against a bench.

NOTE: Sleeve may come out of cylinder with piston rod.

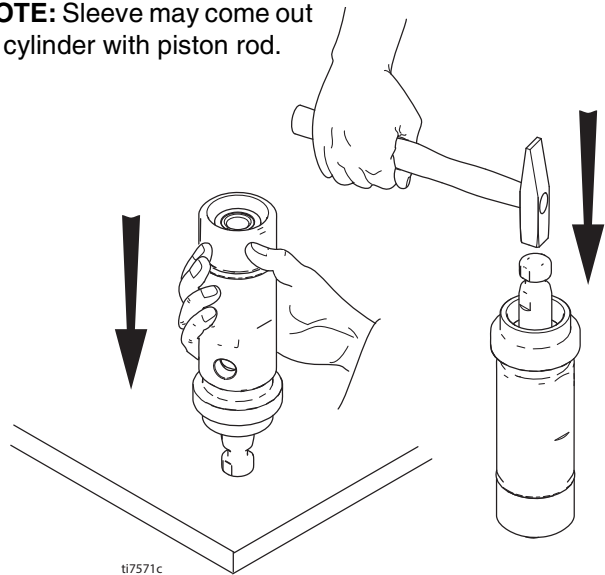

- Remove piston rod from sleeve, or remove sleeve from cylinder. **Mark IV and Mark VII models:** Remove sleeve spacer (230) from sleeve.

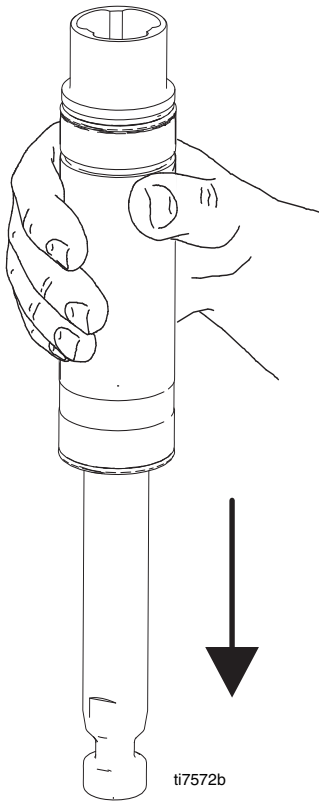

patch allows four disassembly/assembly procedures before it is necessary to apply thread sealant to the threads.

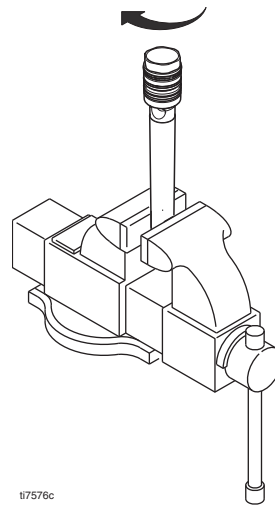

- Remove packings and glands from piston rod.

Not used on 16X414, 16X418

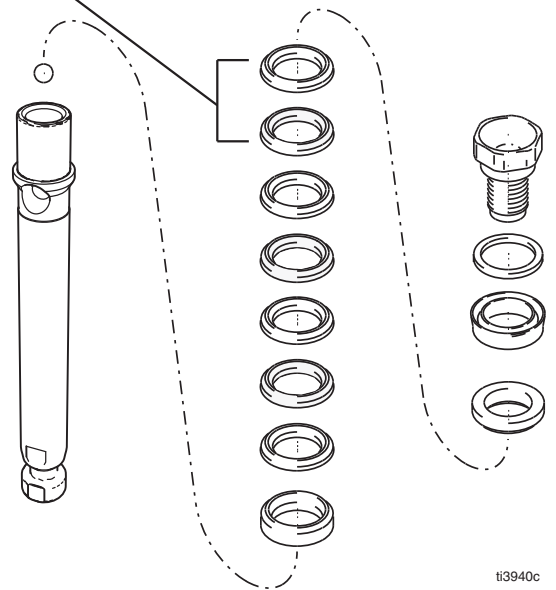

!	MPa bar PSI					
<p>COMPONENT RUPTURE HAZARD</p> <p>To reduce the risk of serious injury from pressurized fluid, do not clean or wipe the piston valve threads. Cleaning the piston valve threads could destroy the special sealing patch and cause the piston valve to come loose during operation.</p>						

- Unscrew piston valve from piston rod. Clean and inspect parts. The piston has a special thread locking/sealing patch. Do not remove the patch. The

- Remove throat packings and glands from cylinder. Discard throat packings and glands.

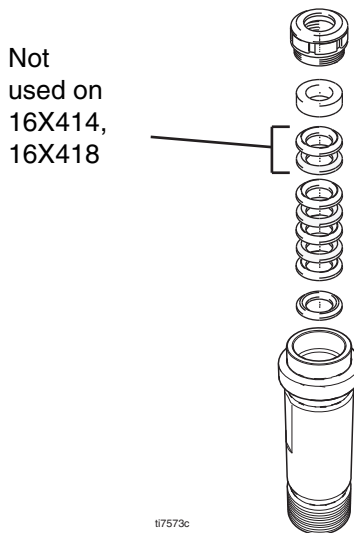

- Install ball (206) in piston rod. If thread sealant is applied to piston valve threads, make sure that none gets on ball.

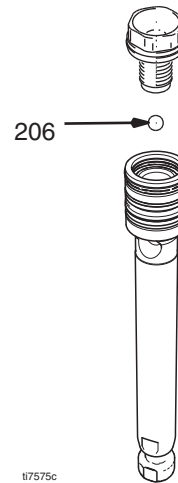

Assembling the Pump

- Soak all leather packings in SAE 30W oil for 1 hour minimum prior to assembly. Stack male gland (204) on piston rod. Alternately stack UHMWPE (208) and leather (218) packings (note orientation) on piston rod. Install female gland (217). Install piston wiper (216) (note orientation) and backup washer (229) on piston valve, threads are good for four repackings. Use thread sealant on piston valve threads after four repackings.

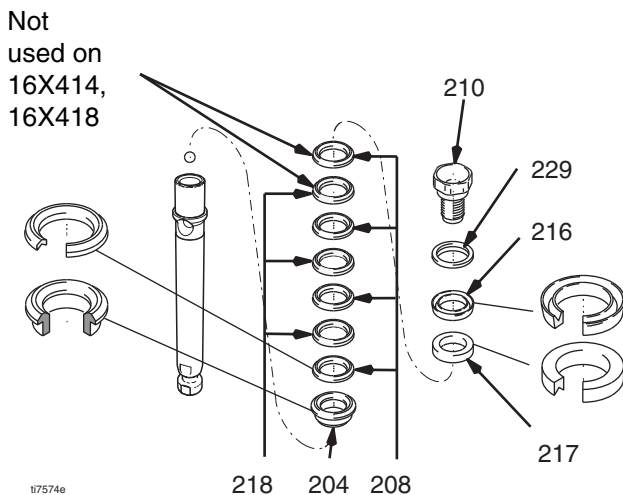

- Tighten piston valve to piston rod as specified:

Models	Torque
16X414, 16X418	27 +/-3 ft-lb. (36.1 +/-4.1 N•m)
16X419, 16X420, 16X421, 16Y602, 16Y599	55 +/-3 ft-lb. (74.6 +/-4.1 N•m)
16X426, 16X427	120 +/-6 ft-lb. (162.7 +/-8.2 N•m)

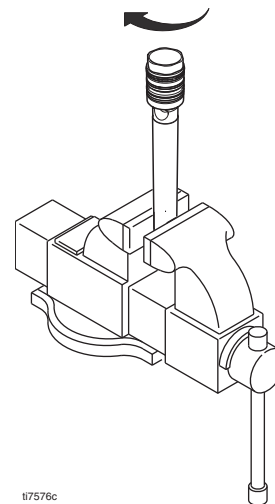

- Soak all leather packings in SAE 30W oil for one hour minimum prior to assembly. Place male gland (204) in cylinder. Alternately stack UHMWPE (203) and leather packings (223) (note orientation). Place female gland (224) in top of cylinder seat packings.

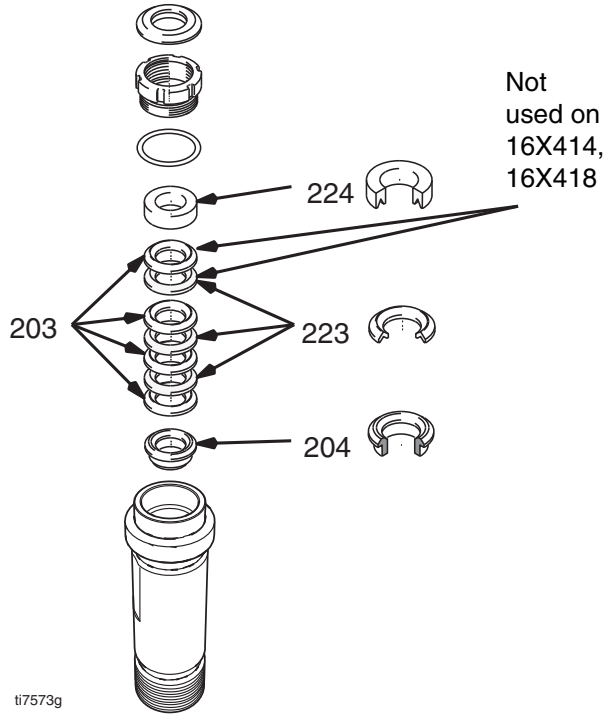

- Install seal (201) into packing nut (202). Install o-ring (228) onto packing nut. Loosely install packing nut into cylinder.

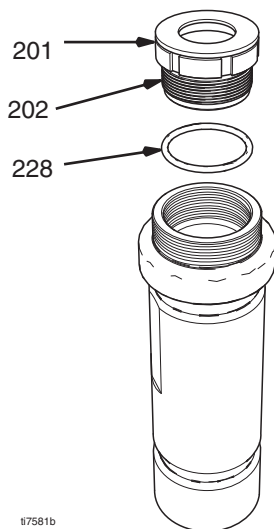

- Grease piston packings.

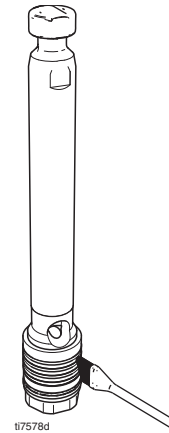

NOTICE

Do not slide piston assembly into top of sleeve as this may damage piston packing.

- Slide piston assembly into bottom of sleeve.

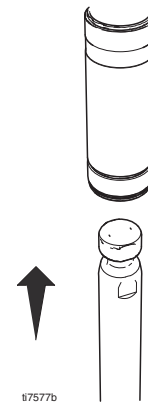

- Grease top inch or two of piston rod that will go through the cylinder throat packings.

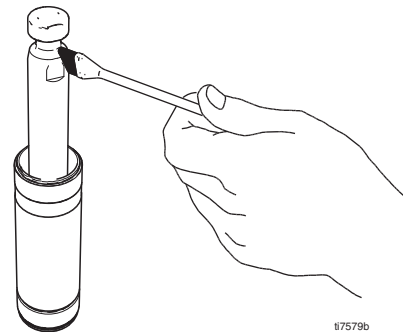

9. Grease o-rings (221) and place on sleeve. Slide sleeve/piston rod assembly into bottom of cylinder. Replace o-ring (207) if desired.

NOTE: O-ring (207) is not required for safe pump operation.

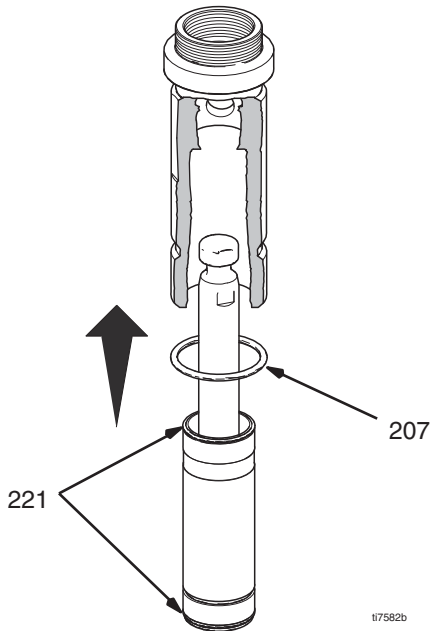

10. **Mark IV and Mark VII models:** Install o-ring (231) on sleeve spacer (230) and install sleeve spacer on sleeve.

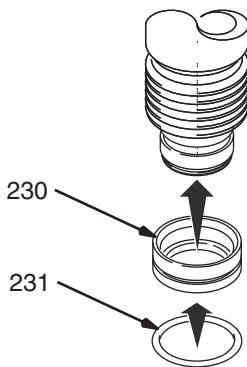

11. Reassemble intake valve with new o-ring (227), seat (212) and ball (214). Seat may be flipped over and used on other side. Clean seat thoroughly.

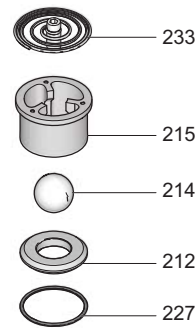

NOTE: Spring (233) only used on 16X426, 16X427, and 16Y602.

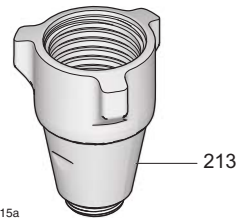

12. Install intake valve on cylinder. If a wrench is used torque as follows:

Models	Torque
16X414, 16X418	67 +/- 5 ft-lb (90.8 +/-6.8 N•m)
16X419, 16X420, 16X421, 16Y602, 16Y599	80 +/- 5 ft-lb (108.5 +/-6.8 N•m)
16X426, 16X427	200 +/- 15 ft-lb (271.2 +/-20.3 N•m)

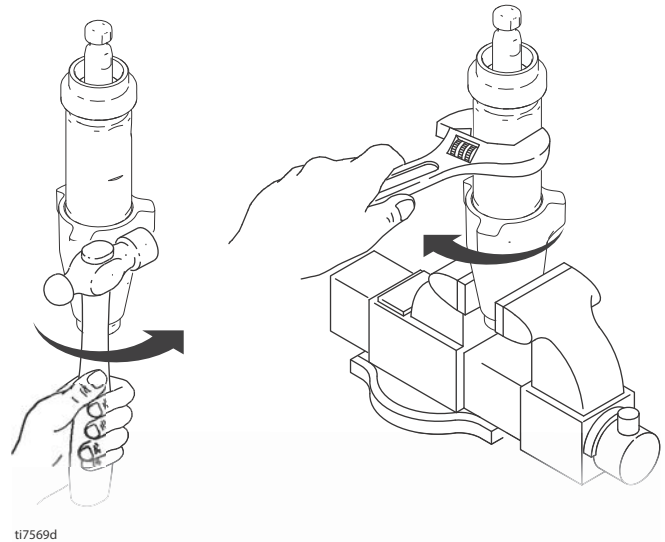

13. Torque packing nut (202) as follows:

Models	Torque
16X414, 16X418, 16X419, 16X420, 16X421, 16Y602, 16Y599	100 +/- 10 in-lb (11.3 +/-1.1 N•m)
16X426, 16X427	75 +/- 5 in-lb (7.9 +/-0.61 N•m)

14. Remove o-ring (228) when pump packings begin to leak after extended use. Then tighten packing nut down until leakage stops or lessens. This allows approximately 100 gallons of additional operation before a repacking is required.

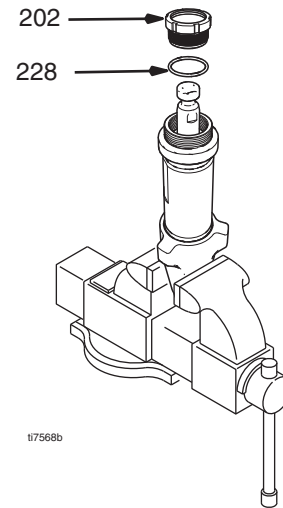

Cross-Section Reference

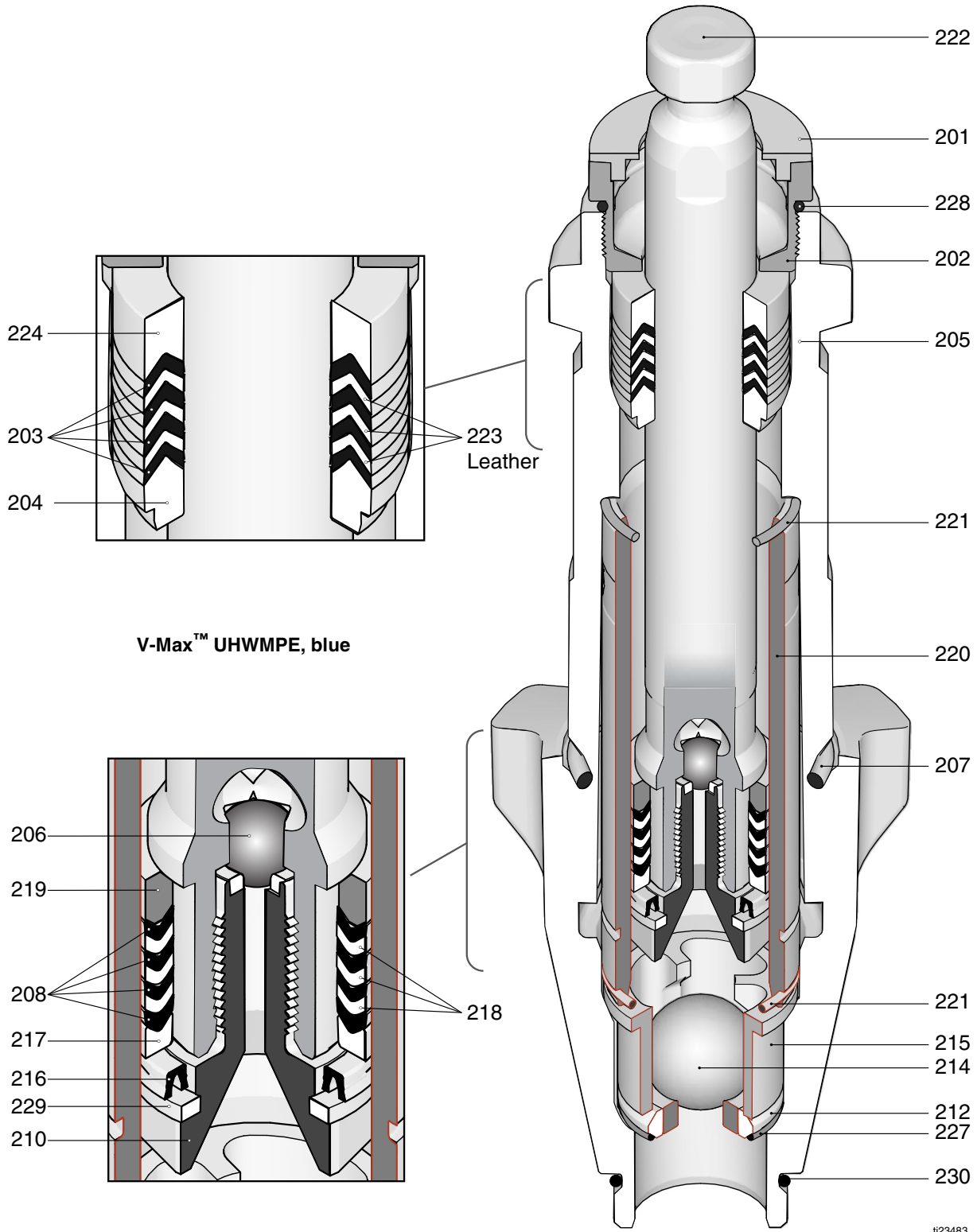

Pump 16X419, 16X420

ti23483

Parts - Pump 16X414, 16X418

Ref.	Part	Description	Qty.
201*†	179810	SEAL, throat	1
202	193046	NUT, packing	1
203*†	192692	V-PACKING, throat, V-Max, UHMWPE, blue	3
204*†	15C987	GLAND, male, throat,	1
205		CYLINDER, pump	1
	16X450	Model 16X414	
	16X456	Model 16X418	
206		BALL check	1
	105444*	Model 16X414 (Stainless steel)	
	119259†	Model 16X418 (Ceramic)	
207*†	156593	PACKING, o-ring	1
208*†	192693	V-PACKING, piston, V-MAX, UHMWPE, blue	3
210	287877	VALVE, piston	1
212		KIT, seat, carbide	1
	239922	Model 16X414, <i>includes 214, 215, 227</i>	
	244571	Model 16X418 <i>includes 214, 227</i>	
213		VALVE, intake (foot)	1
	15C785	Model 16X414	
	287878	Model 16X418	
214		BALL, check, inlet	1
	105445*	Model 16X414 (Stainless steel)	
	111453†	Model 16X418 (Ceramic)	
	102972	Model 16X418 (Stainless steel)	
215		GUIDE, ball	1
	192624	Model 16X414	
	196967	Model 16X418	
216*†	118503	WIPER, piston	1
217*†	178969	GLAND, female, piston	1
218*†	178939	V-PACKING, leather, piston	2
219*†	196880	GLAND, male, piston	1
220	248209	SLEEVE, cylinder	1
221*†	108526	O-RING, ptfe	1
222		ROD, piston	1
	16X434	Model 16X414	
	16X440	Model 16X418	
223*†	178940	V-PACKING, leather, throat	2
224*†	15C988	GLAND, female, throat	1
227		O-RING, ptfe	1
	107079*	Model 16X414	
	108526†	Model 16X418	
228*†	158776	O-RING	1
229*†	15C997	WASHER, backup	1
230*	118494	O-RING, fluoroelastomer (Model 16X414)	1
231†	107098	O-RING (Model 16X418 only)	1
232	15G494	SPACER, sleeve (Model 16X418 only)	1

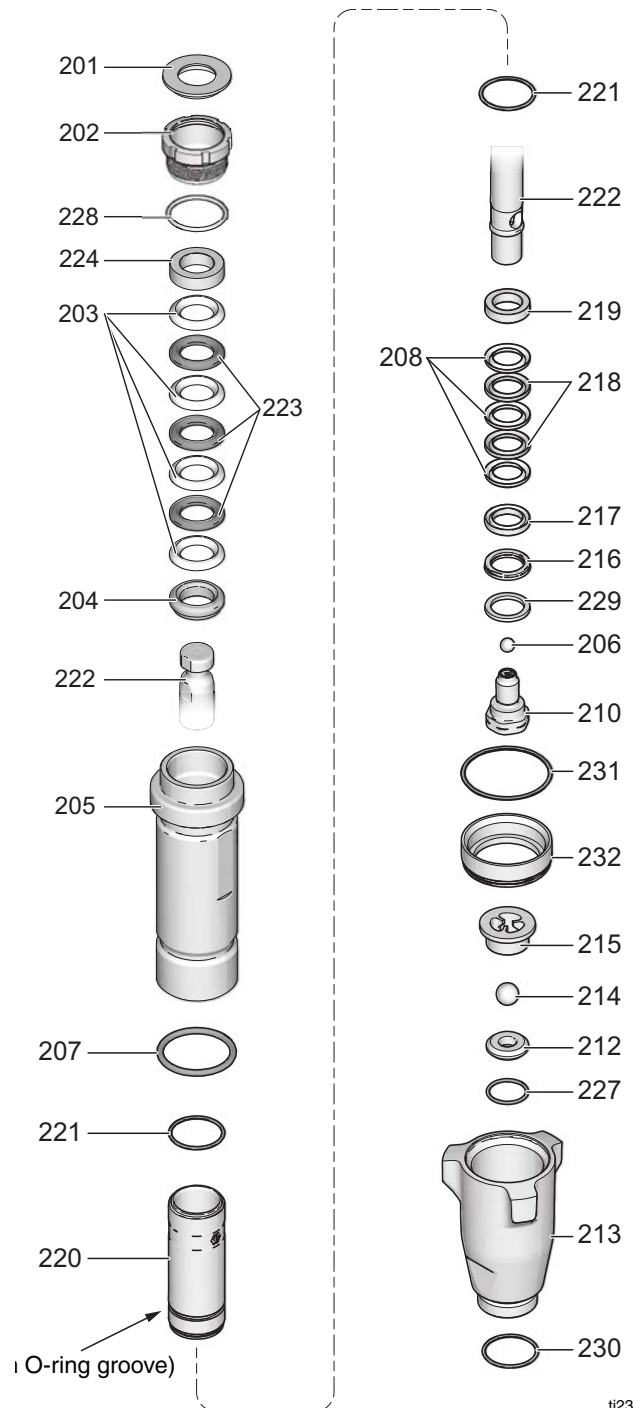

ti23511a

* These parts are also included in Repair Kit 248212, which may be purchased separately.

† These parts are also included in Repair Kit 24V063, which may be purchased separately.

Parts - Pump 16X419, 16X420, 16X421, 16Y599, 16Y602

Ref.	Part	Description	Qty.
201*†	183171	SEAL, throat	1
202	193032	NUT, packing	1
203*†*	193124	V-PACKING, throat, V-Max, UHMWPE, blue	4
204*†*	15C989	GLAND, male, throat	1
205		CYLINDER, pump	1
	16X451	Model 16X419	
	16X452	Model 16X420	
	16X457	Model 16X421	
	16X461	Model 16Y599	
	17A033	Model 16Y602	
206		BALL, check	1
	101947*	Model 16X419, 16X420 (Stainless steel)	
	116327†*	Model 16X421, 16Y599, 16Y602 (Ceramic)	
207		PACKING, o-ring	1
	156633*†	Model 16X419, 16X420, 16X421, 16Y599	
	160325*	Model 16Y602	
208*†*	193125	V-PACKING, piston, V-MAX, UHMWPE, blue	4
210	24U993	VALVE, piston	1
212		KIT, seat, carbide	1
	244199	Model 16X419, 16X420 includes 214, 227	
	244571	Model 16X421, 16Y599 includes 214, 227	
	24N013	Model 16Y602 includes 214, 227, 233	
213		VALVE, intake (foot)	1
	15E654	Model 16X419, 16X420	
	196753	Model 16X421, 16Y599	
	15A303	Model 16Y602	
214		BALL, check, inlet	1
	102972*	Model 16X419, 16X420 (Stainless steel)	
	111453†	Model 16X421, 16Y599 (Ceramic)	
	118602*	Model 16Y602 (Ceramic)	
	107167	Model 16Y602 (Stainless steel)	
215		GUIDE, ball	1
	193027	Model 16X419, 16X420	
	196967	Model 16X421, 16Y599	
	16M658	Model 16Y602	
216*†*	118504	WIPER, piston	1
217*†*	183185	GLAND, female, piston	1
218*†*	15E329	V-PACKING, leather, piston	3
219*†*	183178	GLAND, male, piston	1
220		SLEEVE, cylinder	1
	248210	Model 16X419, 16X421, 16Y602	
	257031	Model 16X420, 16Y599	
221*†*	107098	O-RING, ptfе	2
222		ROD, piston	1
	16X435	Model 16X419	
	16X436	Model 16X420	
	16X441	Model 16X421, 16Y599, 16Y602	
223*†*	183175	V-PACKING, leather, throat	3
224*†*	15C990	GLAND, female, throat	1
227		O-RING, ptfе	1
	108526*†	Model 16X419, 16X420, 16X421, 16Y599	
	107098*	Model 16Y602	
228*†	C20987	O-RING	1
229*†*	15C998	WASHER, backup	1
230*	118494	O-RING, fluoroelastomer (Model 16X419, 16X420 only)	1
231*	108822	O-RING (Model 16Y602 only)	1
232*	16M291	SPACER, sleeve (Model 16Y602 only)	1
233	24E027	SPRING, intake, ball (Model 16Y602 only)	1

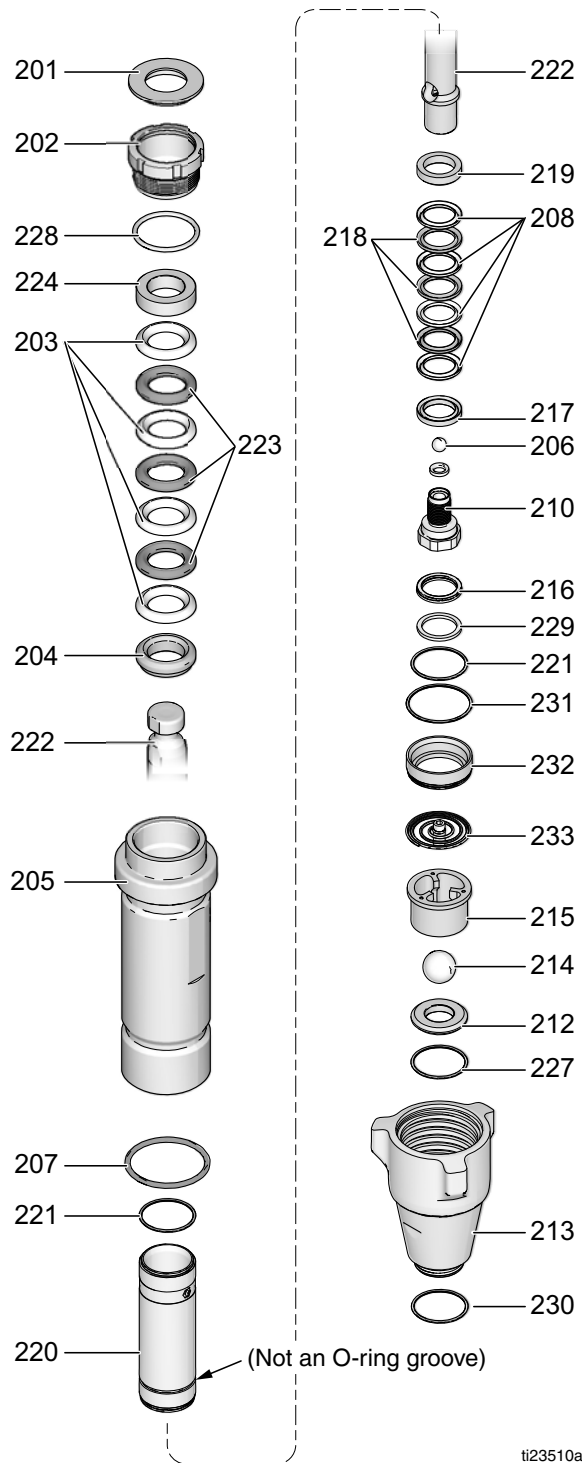

ti23510a

* These parts are also included in Repair Kit 248213, which may be purchased separately.
 † These parts are also included in Repair Kit 16X430, which may be purchased separately.
 * These parts are also included in Repair Kit 24M830, which may be purchased separately.

Parts - Pump 16X426, 16X427

Ref.	Part	Description	Qty.
201*†*	112590	SEAL, throat	1
202	16X768	NUT, packing	1
203*†*	193722	V-PACKING, throat, V-Max, UHMWPE, blue	4
204*†*	15G658	GLAND, male, throat	1
205	16X455 16X460	CYLINDER, pump Model 16X426 Model 16X427	1
206	107203* 118601†*	BALL, check Model 16X426(Stainless steel) Model 16X427 (Ceramic)	1
207*†*	160325	PACKING, o-ring	1
208*†*	193722	V-PACKING, piston, V-MAX, UHMWPE, blue	4
210	249177	VALVE, piston	1
212	240918 16X467 24N013	KIT, seat, carbide Model 16X426 <i>includes 214, 227</i> (stainless steel check ball) Model 16X426 <i>includes 214, 227, 231</i> (ceramic check ball) Model 16X427 <i>includes 214, 227, 231</i>	1
213	15E655 15A303	VALVE, intake (foot) Model 16X426 Model 16X427	1
214	107167* 118602†*	BALL, check, inlet Model 16X426 (Stainless steel) Model 16X427 (Ceramic)	1
215	198505 193391	GUIDE, ball Model 16X426 Model 16X427	1
216*†*	119636	WIPER, piston	1
217*†*	189588	GLAND, female, piston	1
218	15E639* 112591†	V-PACKING, leather, piston 16X426 16X427	3
219*†*	189585	GLAND, male, piston	1
220	249121	SLEEVE, cylinder	1
221*†*	108822	O-RING, ptfе	2
222	16X439 16X443	ROD, piston Model 16X426 Model 16X427	1
223*†*	112591	V-PACKING, leather, throat	3
224*†*	15G657	GLAND, female, throat	1
227*†*	107098	O-RING, ptfе	1
228*†*	156593	O-RING	1
229*†*	15J800	WASHER, backup	1
230	118494	O-RING, fluoroelastomer (Model 16X426 only)	1
231	249770* 24E027†	SPRING, intake, ball Model 16X426 Model 16X427	1

* These parts are also included in Repair Kit 249123, which may be purchased separately.

† These parts are also included in Repair Kit 16X431, which may be purchased separately.

* These parts are also included in Repair Kit 17A578, which may be purchased separately.

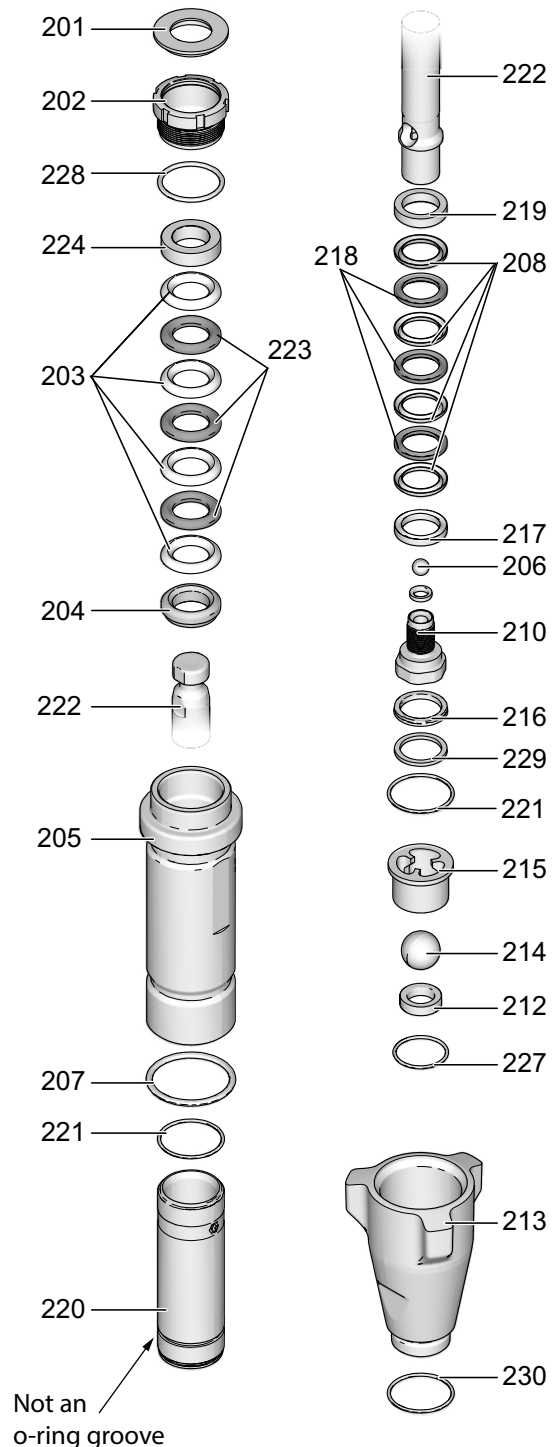

ti23507a

Technical Data

	U.S.	Metric
Maximum Working Pressure	3300 psi	227 bar, 22.7 MPa
Fluid Inlet Size	1-5/16-12 un(m)	1-5/16-12 un(m)
Fluid Outlet Size		
16X414, 16X418, 16X419, 16X420, 16X421, 16Y602, 16Y599	3/8 npt(f)	3/8 npt(f)
16X426, 16X427	1/2 npt(f)	1/2 npt(f)
Wetted Parts	stainless steel, PTFE, leather, nylon, zinc-plated carbon steel, tungsten carbide, chrome plating, fluoroelastomer, acetal, polyethylene	

Graco Standard Warranty

Graco warrants all equipment referenced in this document which is manufactured by Graco and bearing its name to be free from defects in material and workmanship on the date of sale to the original purchaser for use. With the exception of any special, extended, or limited warranty published by Graco, Graco will, for a period of twelve months from the date of sale, repair or replace any part of the equipment determined by Graco to be defective. This warranty applies only when the equipment is installed, operated and maintained in accordance with Graco's written recommendations.

This warranty does not cover, and Graco shall not be liable for general wear and tear, or any malfunction, damage or wear caused by faulty installation, misapplication, abrasion, corrosion, inadequate or improper maintenance, negligence, accident, tampering, or substitution of non-Graco component parts. Nor shall Graco be liable for malfunction, damage or wear caused by the incompatibility of Graco equipment with structures, accessories, equipment or materials not supplied by Graco, or the improper design, manufacture, installation, operation or maintenance of structures, accessories, equipment or materials not supplied by Graco.

This warranty is conditioned upon the prepaid return of the equipment claimed to be defective to an authorized Graco distributor for verification of the claimed defect. If the claimed defect is verified, Graco will repair or replace free of charge any defective parts. The equipment will be returned to the original purchaser transportation prepaid. If inspection of the equipment does not disclose any defect in material or workmanship, repairs will be made at a reasonable charge, which charges may include the costs of parts, labor, and transportation.

THIS WARRANTY IS EXCLUSIVE, AND IS IN LIEU OF ANY OTHER WARRANTIES, EXPRESS OR IMPLIED, INCLUDING BUT NOT LIMITED TO WARRANTY OF MERCHANTABILITY OR WARRANTY OF FITNESS FOR A PARTICULAR PURPOSE.

Graco's sole obligation and buyer's sole remedy for any breach of warranty shall be as set forth above. The buyer agrees that no other remedy (including, but not limited to, incidental or consequential damages for lost profits, lost sales, injury to person or property, or any other incidental or consequential loss) shall be available. Any action for breach of warranty must be brought within two (2) years of the date of sale.

GRACO MAKES NO WARRANTY, AND DISCLAIMS ALL IMPLIED WARRANTIES OF MERCHANTABILITY AND FITNESS FOR A PARTICULAR PURPOSE, IN CONNECTION WITH ACCESSORIES, EQUIPMENT, MATERIALS OR COMPONENTS SOLD BUT NOT MANUFACTURED BY GRACO. These items sold, but not manufactured by Graco (such as electric motors, switches, hose, etc.), are subject to the warranty, if any, of their manufacturer. Graco will provide purchaser with reasonable assistance in making any claim for breach of these warranties.

In no event will Graco be liable for indirect, incidental, special or consequential damages resulting from Graco supplying equipment hereunder, or the furnishing, performance, or use of any products or other goods sold hereto, whether due to a breach of contract, breach of warranty, the negligence of Graco, or otherwise.

FOR GRACO CANADA CUSTOMERS

The Parties acknowledge that they have required that the present document, as well as all documents, notices and legal proceedings entered into, given or instituted pursuant hereto or relating directly or indirectly hereto, be drawn up in English. Les parties reconnaissent avoir convenu que la rédaction du présente document sera en Anglais, ainsi que tous documents, avis et procédures judiciaires exécutés, donnés ou intentés, à la suite de ou en rapport, directement ou indirectement, avec les procédures concernées.

Graco Information

For the latest information about Graco products, visit www.graco.com.

For patent information, see www.graco.com/patents.

TO PLACE AN ORDER, contact your Graco distributor or call 1-800-690-2894 to identify the nearest distributor.

*All written and visual data contained in this document reflects the latest product information available at the time of publication.
Graco reserves the right to make changes at any time without notice.*

Original instructions. This manual contains English. MM 332922

Graco Headquarters: Minneapolis
International Offices: Belgium, China, Japan, Korea

GRACO INC. AND SUBSIDIARIES • P.O. BOX 1441 • MINNEAPOLIS MN 55440-1441 • USA

Copyright 2014, Graco Inc. All Graco manufacturing locations are registered to ISO 9001.

www.graco.com
Revision A - April 2014