

Table of Contents

| | | | |
|----------------------|----|-------------------------|----|
| List of Models | 2 | Parts | 14 |
| Warnings | 3 | Dimensions | 21 |
| Setup | 6 | Technical Data | 22 |
| Operation | 10 | Graco Warranty | 24 |
| Maintenance | 13 | Graco Information | 24 |

List of Models

| Package Part No. | Series | Pump Model | Ratio | Maximum Fluid Working Pressure | Maximum Air Input Pressure |
|------------------|--------|---------------------------------------------------------------------------------|-------|--------------------------------|-----------------------------|
| 232439 | B | Monark®, carbon steel, with hose and gun, without agitator | 23:1 | 2300 psi (16 MPa, 160 bar) | 100 psi (0.7 MPa, 7 bar) |
| 232440 | A | Monark®, carbon steel, without agitator, hose, and gun | 23:1 | 2300 psi (16 MPa, 160 bar) | 100 psi (0.7 MPa, 7 bar) |
| 232443 | B | Monark®, carbon steel, with agitator, hose, and gun | 23:1 | 2300 psi (16 MPa, 160 bar) | 100 psi (0.7 MPa, 7 bar) |
| 232451 | B | Monark®, stainless steel, with hose and gun, without agitator | 23:1 | 2300 psi (16 MPa, 160 bar) | 100 psi (0.7 MPa, 7 bar) |
| 232452 | A | Monark®, stainless steel, without agitator, hose, and gun | 23:1 | 2300 psi (16 MPa, 160 bar) | 100 psi (0.7 MPa, 7 bar) |
| 232455 | B | Monark®, stainless steel, with agitator, hose, and gun | 23:1 | 2300 psi (16 MPa, 160 bar) | 100 psi (0.7 MPa, 7 bar) |
| 232457 | B | Monark®, stainless steel, with fluid regulator, hose, and gun, without agitator | 15:1 | 1500 psi (10 MPa, 100 bar) | 100 psi (0.7 MPa, 7 bar) |
| 232458 | A | Monark®, stainless steel, with fluid regulator, without agitator, hose, and gun | 15:1 | 1500 psi (10 MPa, 100 bar) | 100 psi (0.7 MPa, 7 bar) |
| 232461 | B | Monark®, stainless steel, with fluid regulator, agitator, hose, and gun | 15:1 | 1500 psi (10 MPa, 100 bar) | 100 psi (0.7 MPa, 7 bar) |
| 232463 | B | Monark®, carbon steel, with fluid regulator, hose, and gun, without agitator | 15:1 | 1500 psi (10 MPa, 100 bar) | 100 psi (0.7 MPa, 7 bar) |
| 232464 | A | Monark®, carbon steel, with fluid regulator, without agitator, hose, and gun | 15:1 | 1500 psi (10 MPa, 100 bar) | 100 psi (0.7 MPa, 7 bar) |
| 232467 | B | Monark®, carbon steel, with fluid regulator, agitator, hose, and gun | 15:1 | 1500 psi (10 MPa, 100 bar) | 100 psi (0.7 MPa, 7 bar) |

Symbols

Warning Symbol



This symbol alerts you to the possibility of serious injury or death if you do not follow the instructions.

Caution Symbol



This symbol alerts you to the possibility of damage to or destruction of equipment if you do not follow the instructions.

WARNING



INSTRUCTIONS

EQUIPMENT MISUSE HAZARD

Equipment misuse can cause the equipment to rupture or malfunction and result in serious injury.

- This equipment is for professional use only.
- Read all instruction manuals, tags, and labels before operating the equipment.
- Use the equipment only for its intended purpose. If you are uncertain about usage, call your Graco distributor.
- Do not alter or modify this equipment. Use only genuine Graco parts and accessories.
- Check equipment daily. Repair or replace worn or damaged parts immediately.
- Do not exceed the maximum working pressure of the lowest rated system component. Refer to the **Technical Data** on page 22 for the maximum working pressure of this equipment.
- Use fluids and solvents which are compatible with the equipment wetted parts. Refer to the **Technical Data** section of all equipment manuals. Read the fluid and solvent manufacturer's warnings.
- Route hoses away from traffic areas, sharp edges, moving parts, and hot surfaces. Do not expose Graco hoses to temperatures above 180°F (82°C) or below -40°F (-40°C).
- Wear hearing protection when operating this equipment.
- Do not lift pressurized equipment.
- Comply with all applicable local, state, and national fire, electrical, and safety regulations.

WARNING

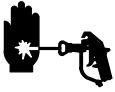

INJECTION HAZARD

Spray from the gun, hose leaks, or ruptured components can inject fluid into your body and cause extremely serious injury, including the need for amputation. Fluid splashed in the eyes or on the skin can also cause serious injury.



- Fluid injected into the skin might look like just a cut, but it is a serious injury. **Get immediate surgical treatment.**
- Do not point the gun at anyone or at any part of the body.
- Do not put your hand or fingers over the spray tip.
- Do not stop or deflect leaks with your hand, body, glove or rag.
- Do not “blow back” fluid; this is not an air spray system.
- Always have the tip guard and the trigger guard on the gun when spraying.
- Check the gun diffuser operation weekly. Refer to the gun manual.
- Be sure the gun trigger safety operates before spraying.
- Lock the gun trigger safety when you stop spraying.
- Follow the **Pressure Relief Procedure** on page 10 whenever you: are instructed to relieve pressure; stop spraying; clean, check, or service the equipment; and install or clean the spray tip.
- Tighten all fluid connections before operating the equipment.
- Check the hoses, tubes, and couplings daily. Replace worn, damaged, or loose parts immediately. Permanently coupled hoses cannot be repaired; replace the entire hose.
- Use only Graco approved hoses. Do not remove any spring guard that is used to help protect the hose from rupture caused by kinks or bends near the couplings.



MOVING PARTS HAZARD

Moving parts, such as the air motor piston, can pinch or amputate your fingers.

- Keep clear of all moving parts when starting or operating the pump.
- Before servicing the equipment, follow the **Pressure Relief Procedure** on page 10 to prevent the equipment from starting unexpectedly.

WARNING



FIRE AND EXPLOSION HAZARD

Improper grounding, poor ventilation, open flames or sparks can cause a hazardous condition and result in a fire or explosion and serious injury.

- Ground the equipment and the object being sprayed. Refer to **Grounding** on page 7.
- If there is any static sparking or you feel an electric shock while using this equipment, **stop spraying immediately**. Do not use the equipment until you identify and correct the problem.
- Provide fresh air ventilation to avoid the buildup of flammable fumes from solvents or the fluid being sprayed.
- Keep the spray area free of debris, including solvent, rags, and gasoline.
- Electrically disconnect all equipment in the spray area.
- Extinguish all open flames or pilot lights in the spray area.
- Do not smoke in the spray area.
- Do not turn on or off any light switch in the spray area while operating or if fumes are present.
- Do not operate a gasoline engine in the spray area.



TOXIC FLUID HAZARD

Hazardous fluid or toxic fumes can cause serious injury or death if splashed in the eyes or on the skin, inhaled, or swallowed.

- Know the specific hazards of the fluid you are using.
- Store hazardous fluid in an approved container. Dispose of hazardous fluid according to all local, state and national guidelines.
- Always wear protective eyewear, gloves, clothing and respirator as recommended by the fluid and solvent manufacturer.

Setup

General Information

NOTE: Reference numbers and letters in parentheses in the text refer to the callouts in the figures and the parts drawing.

NOTE: Always use Genuine Graco Parts and Accessories, available from your Graco distributor. Refer to Product Data Sheet 305899. If you supply your own accessories, be sure they are adequately sized and pressure-rated for your system.

Fig. 2 is only a guide for selecting and installing system components and accessories. Contact your Graco distributor for assistance in designing a system to suit your particular needs.

Prepare the Operator

All persons who operate the equipment must be trained in the safe, efficient operation of all system components as well as the proper handling of all fluids. All operators must thoroughly read all instruction manuals, tags, and labels before operating the equipment.

The following manuals are included with this equipment:

- 308766, Pail Mount Air-Assisted Packages
- 307619, 23:1 CST and SST Monark Pumps, or 308106, 15:1 SST Monark Pump, or 306981, 15:1 CST Monark Pump, or 307595, 10:1 CST Monark Pump
- 307043, Monark Air Motor
- 308686, Air Regulator Kit
- 307273, Fluid Filter

- 307886, Fluid Pressure Regulator (included on 15:1 Monarks only)
- 306565, Agitator (included on Models 232443, 232455, 232461, and 232467 only)
- 311001, AA Series Spray Gun (included on all models except 232440, 232452, 232458, and 232464)

Prepare the Site

NOTE: The compressed air supply to the gun must be clean and dry, to prevent damage to the finish. Use a coalescing air filter in the main air supply line.

Ensure that you have an adequate compressed air supply. Refer to the performance charts on page 23 to find the air consumption of your pump.

Refer to Fig. 2 on page 9. Bring a compressed air supply line from the air compressor to the pump location. Be sure all air hoses are properly sized and pressure-rated for your system. Use only electrically conductive hoses. The air hose (A) should have a 3/8 npsm(m) thread.

Install a bleed-type shutoff valve (B) in the air line to isolate the air line components for servicing. Install an air line filter (C) and a moisture trap and drain valve (D) to help remove moisture and contaminants from the compressed air supply.

Keep the site clear of any obstacles or debris that could interfere with the operator's movement.

Have a grounded, metal pail available for use when flushing the system.

Setup

Grounding

⚠ WARNING

FIRE AND EXPLOSION HAZARD
Before operating the pump, ground the system as explained below. Also read the section **FIRE AND EXPLOSION HAZARD** on page 5.

1. *Pump*: use the ground wire and clamp (supplied). See Fig. 1. Loosen the grounding lug locknut (W) and washer (X). Insert one end of the ground wire (18) into the slot in lug (Z) and tighten the locknut securely. Connect the other end of the wire to a true earth ground.
2. *Agitator (Models 232443, 232455, 232461, and 232467 only)*: one end of the agitator ground wire (40, supplied) is fastened to the agitator motor with a screw. Insert the other end of the ground wire into the slot in lug (Z). Insert the pump ground wire (18) as described in step 1 and tighten the locknut (W) securely.
3. *Air and fluid hoses*: use only electrically conductive hoses.
4. *Air compressor*: follow manufacturer's recommendations.
5. *Spray gun*: ground through connection to a properly grounded fluid hose and pump.
6. *Fluid supply container*: follow your local code.
7. *Object being sprayed*: follow your local code.
8. *Solvent pails used when flushing*: follow your local code. Use only metal pails, which are conductive, placed on a grounded surface. Do not place the pail on a nonconductive surface, such as paper or cardboard, which interrupts the grounding continuity.
9. *To maintain grounding continuity when flushing or relieving pressure*, hold a metal part of the spray gun firmly to the side of a grounded *metal* pail, then trigger the gun.

1 Models with agitator only.

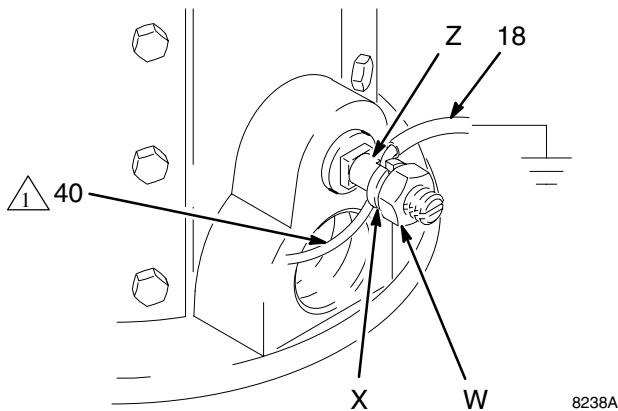

Fig. 1

Setup

Supplied Components

Refer to Fig. 2.

WARNING

A red-handled bleed-type master air valve (E) and a fluid drain valve (F) are supplied. These components help reduce the risk of serious injury, including fluid injection and splashing of fluid in the eyes or on the skin, and injury from moving parts if you are adjusting or repairing the pump.

The bleed-type master air valve relieves air trapped between this valve and the pump after the valve is closed. Trapped air can cause the pump to cycle unexpectedly. Locate the valve close to the pump.

The fluid drain valve assists in relieving fluid pressure in the displacement pump, hose, and gun. Triggering the gun to relieve pressure may not be sufficient.

- **The red-handled bleed-type master air valve (E)** is required in your system to relieve air trapped between it and the air motor and gun when the valve is closed (see the **WARNING** above). Do not block access to the valve.
- **The pump air regulator (G)** controls pump speed and outlet pressure by adjusting the air pressure to the pump.
- **The air relief valve (15)** opens automatically to prevent overpressurization of the pump.
- **The gun air regulator (J)** adjusts the air pressure to the air-assisted spray gun (106).
- **The air inlet swivel (H)** connects incoming air to the pump and to the gun.
- **The strainer (42)** keeps large particles from entering the pump.
- **The fluid filter (13)** includes a 60 mesh (250 micron) stainless steel element to filter particles from the fluid as it leaves the pump. It also includes the **fluid drain valve (F)**, which is required in your system to relieve fluid pressure in the hose and gun (see the **WARNING** at left).
- **The agitator (39)**, included on Models 232443, 232455, 232461, 232467, and 232473 only, keeps the fluid in suspension.
- **The air-assisted spray gun (106)** dispenses the fluid. The gun houses the **spray tip (107)**, which is available in a wide range of sizes for different spray patterns and rates of flow.
- The **twin hose (101)** includes a **gun air supply hose (101a)** and a **gun fluid supply hose (101b)**. The **fluid whip hose (103)** allows greater gun maneuverability.
- **The gun filter/swivel (104)** provides a final filtering of fluid before it enters the gun, and allows greater gun maneuverability.
- **The fluid pressure regulator (201)**, included on 15:1 Monarks only, allows more precise adjustment of the fluid pressure at the gun.

Setup

Model 232443 Shown

KEY

SUPPLIED COMPONENTS

- 1 5 Gallon (19 liter) Pail Cover
- 2 Pump
- 13 Fluid Filter
(includes fluid drain valve F)
- 15 Air Relief Valve
- 18 Pump Ground Wire (required;
see page 7 for installation instructions)
- 19 5 Gallon (19 liter) Pail
- 39 Agitator
- 40 Agitator Ground Wire
- 101 Electrically Conductive Gun Air/Fluid Hose
(includes items 101a and 101b)
- 101a Gun Air Supply Hose
- 101b Gun Fluid Supply Hose
- 103 Fluid Whip Hose
- 104 Gun Filter/Swivel
- 106 Air-Assisted Spray Gun
- 201 Fluid Pressure Regulator
(15:1 Monarks only)
- E* Red-Handled Bleed-Type Master Air Valve
(required, for pump)
- F Fluid Drain Valve
- G* Pump Air Regulator
- H* Air Inlet Swivel
- J* Gun Air Regulator

* Included in Air Regulation Kit (21).

COMPONENTS YOU MUST SUPPLY

- A Electrically Conductive Air Supply Hose
- B Bleed-Type Master Air Valve (for accessories)
- C Air Line Filter
- D Air Line Moisture Trap and Drain Valve

 Fluid Pressure Regulator included with 10:1 and 15:1 Monarks only

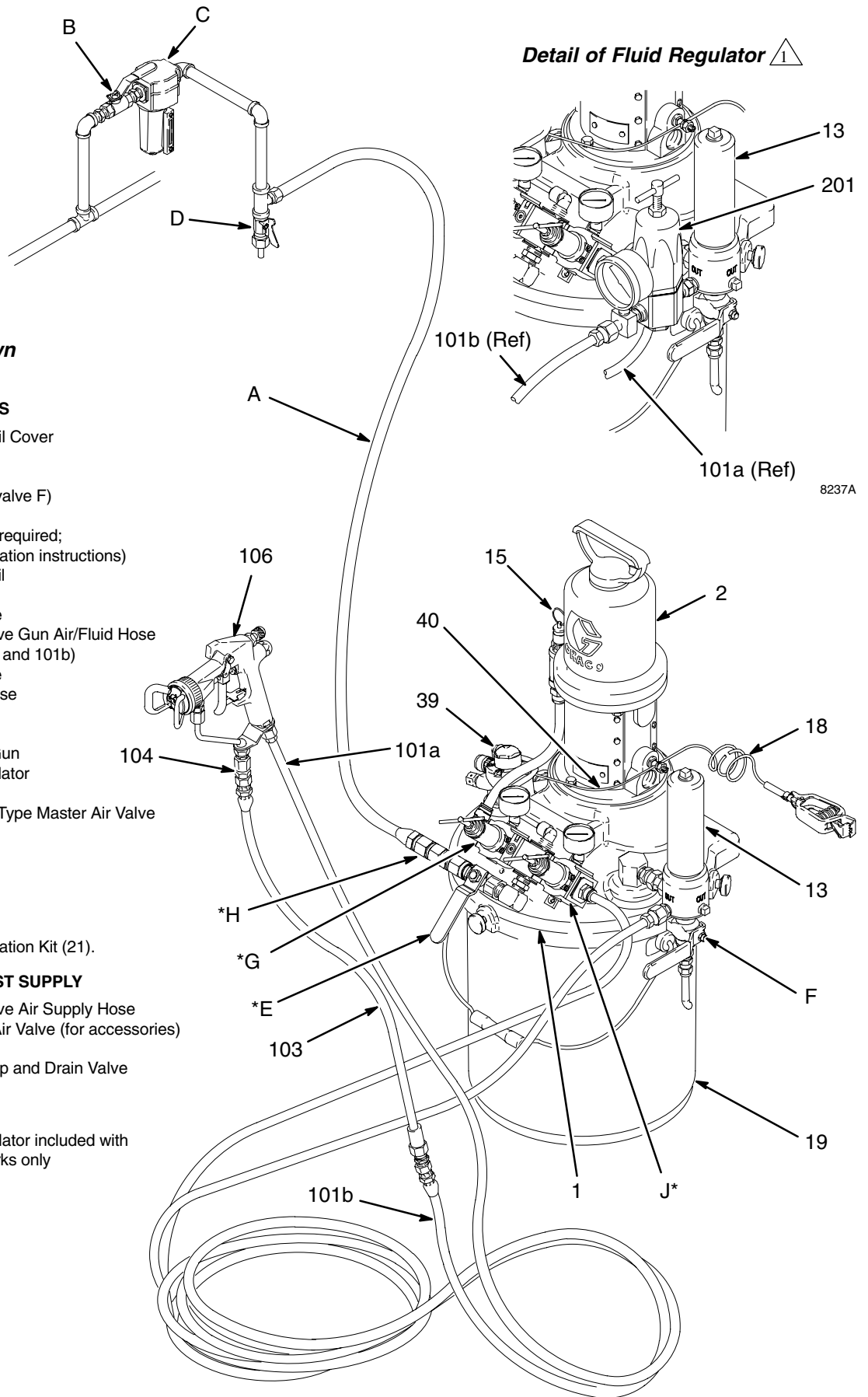

Fig. 2

8163A

Operation

Pressure Relief Procedure

WARNING

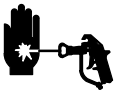

INJECTION HAZARD

The system pressure must be manually relieved to prevent the system from starting or spraying accidentally. Fluid under high pressure can be injected through the skin and cause serious injury. To reduce the risk of an injury from injection, splashing fluid, or moving parts, follow the **Pressure Relief Procedure** whenever you:

- are instructed to relieve the pressure,
- stop spraying,
- check or service any of the system equipment,
- or install or clean the spray tip.

1. Lock the gun trigger safety.
2. Close the red-handled bleed-type master air valve (E, required in your system). See Fig. 3.
3. Unlock the gun trigger safety.
4. Hold a metal part of the gun firmly to the side of a grounded metal pail, and trigger the gun to relieve pressure.
5. Lock the gun trigger safety.
6. Open the drain valve (F, required in your system), having a container ready to catch the drainage.
7. Leave the drain valve open until you are ready to spray again.

*If you suspect that the spray tip or hose is completely clogged, or that pressure has not been fully relieved after following the steps above, **very slowly** loosen the tip guard retaining nut or hose end coupling and relieve pressure gradually, then loosen completely. Now clear the tip or hose.*

Flush the Pump Before First Use

The pump is tested with lightweight oil, which is left in to protect the pump parts. If the fluid you are using may be contaminated by the oil, flush it out with a compatible solvent. See **Flushing** on page 13.

Packing Nut

Before starting, fill the packing nut 1/3 full with Graco Throat Seal Liquid (TSL) or compatible solvent. See your separate pump manual.

WARNING

To reduce the risk of serious injury whenever you are instructed to relieve pressure, always follow the **Pressure Relief Procedure** at left.

The packing nut is torqued at the factory and is ready for operation. If it becomes loose and there is leaking from the throat packings, relieve pressure, then torque the nut as specified in your separate pump manual. Do this whenever necessary. Do not overtighten the packing nut.

Prime the Pump

1. See Fig. 3. Remove the tip guard and spray tip from the gun (106). Refer to the gun manual.
2. Close the gun air regulator (J), pump air regulator (G), and bleed-type air valves (B, E).
3. Connect the air line (A) to the air inlet swivel (H).
4. Check that all fittings throughout the system are tightened securely.
5. Fill the pail (19) with fluid. Make sure the pail cover (1) is fastened securely to the pail with the screw knobs (20).
6. Close the fluid drain valve (F). Open the fluid regulator (201), if present.
7. Hold a metal part of the gun (106) firmly to the side of a grounded metal pail and hold the trigger open.
8. Open the bleed-type air valves (B, E) and the gun air regulator (J). Slowly open the pump air regulator (G) until the pump starts.
9. Cycle the pump slowly until all air is pushed out and the pump and hoses are fully primed.
10. Release the gun trigger and lock the trigger safety. The pump should stall against pressure.
11. If the pump fails to prime properly, open the drain valve (F). Use the drain valve as a priming valve until the fluid flows from the valve. Close the valve.

NOTE: When changing fluid containers with the hose and gun already primed, open the drain valve (F) to help prime the pump and vent air before it enters the hose. Close the drain valve when all air is eliminated.

Operation

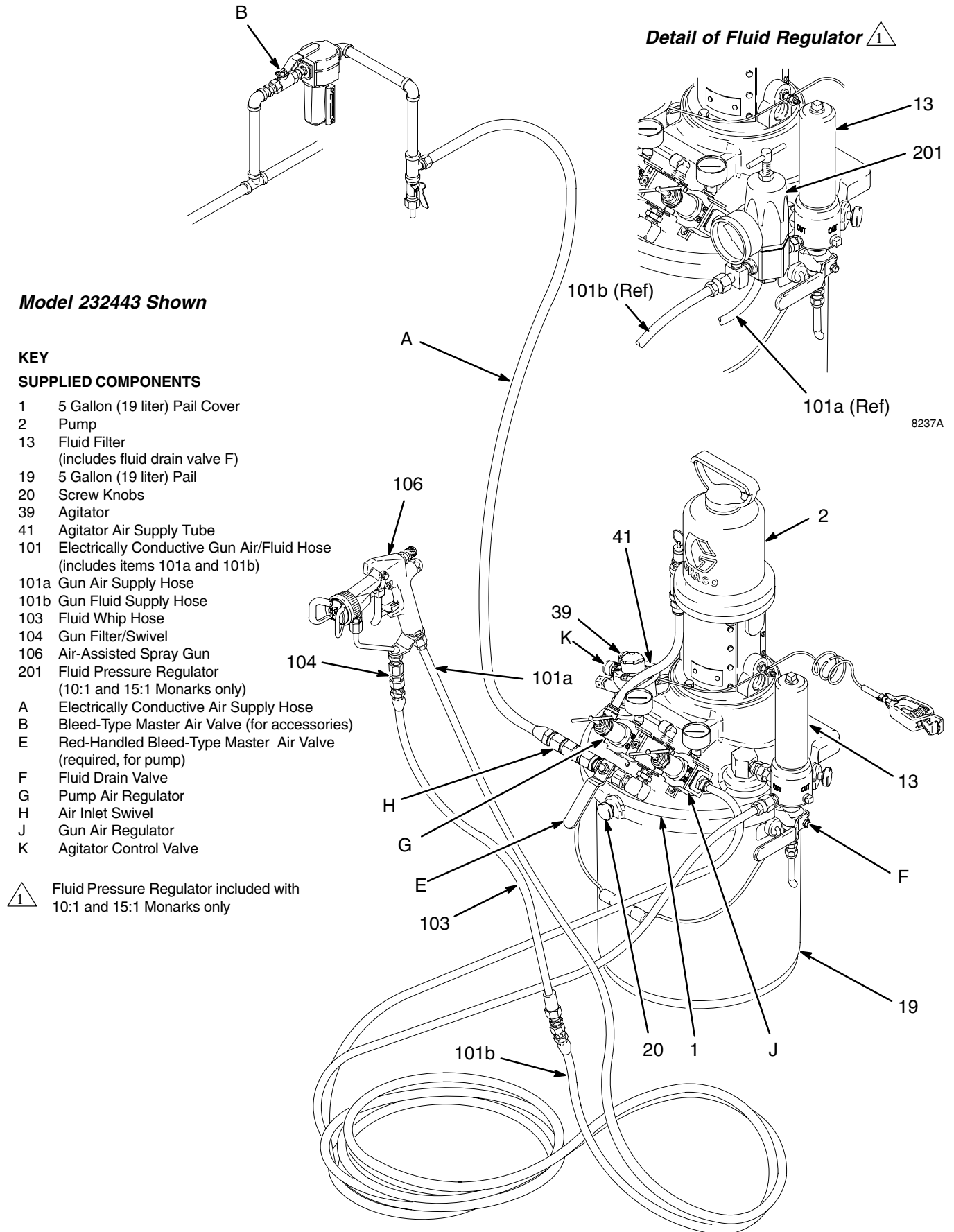

Model 232443 Shown

KEY

SUPPLIED COMPONENTS

- 1 5 Gallon (19 liter) Pail Cover
- 2 Pump
- 13 Fluid Filter
(includes fluid drain valve F)
- 19 5 Gallon (19 liter) Pail
- 20 Screw Knobs
- 39 Agitator
- 41 Agitator Air Supply Tube
- 101 Electrically Conductive Gun Air/Fluid Hose
(includes items 101a and 101b)
- 101a Gun Air Supply Hose
- 101b Gun Fluid Supply Hose
- 103 Fluid Whip Hose
- 104 Gun Filter/Swivel
- 106 Air-Assisted Spray Gun
- 201 Fluid Pressure Regulator
(10:1 and 15:1 Monarks only)
- A Electrically Conductive Air Supply Hose
- B Bleed-Type Master Air Valve (for accessories)
- E Red-Handled Bleed-Type Master Air Valve
(required, for pump)
- F Fluid Drain Valve
- G Pump Air Regulator
- H Air Inlet Swivel
- J Gun Air Regulator
- K Agitator Control Valve

Fluid Pressure Regulator included with 10:1 and 15:1 Monarks only

8237A

Fig. 3

8163A

Operation

Agitator Operation (Models 232443, 232455, 232461, and 232467 only)

1. Slowly open the control valve (K) to start the agitator (39). See Fig. 3.
2. Use the valve (K) to adjust the speed. Do not operate the agitator too fast. If the fluid foams or a vortex forms on the fluid surface, reduce the speed of the agitator.
3. Refer to manual 306565 for further agitator operating instructions.

Install the Spray Tip

WARNING

To reduce the risk of serious injury whenever you are instructed to relieve pressure, always follow the **Pressure Relief Procedure** on page 10.

Relieve the pressure. Install the spray tip and tip guard as explained in your separate gun manual, supplied.

The fluid output and pattern width depend on the size of the spray tip, the fluid viscosity, and the fluid pressure. Use the **Spray Tip Selection Chart** in your gun instruction manual as a guide for selecting an appropriate spray tip for your application.

Adjust the Spray Pattern

1. Start the pump. Use the pump air regulator (G) to adjust the pump speed and fluid pressure until the spray is completely atomized. Use the lowest pressure necessary to get the desired results. Higher pressure may not improve the spray pattern and will cause premature tip and pump wear.

NOTE: The fluid pressure regulator (201), which is included on 10:1 and 15:1 Monarks, allows more precise adjustment of the fluid pressure at the gun.

WARNING

COMPONENT RUPTURE HAZARD



To reduce the risk of overpressurizing your package, which could cause component rupture and serious injury, *never exceed 100 psi (0.7 MPa, 7 bar) air input pressure to the package. Never exceed 100 psi (0.7 MPa, 7 bar) air input pressure to the spray gun.* Also refer to the **Technical Data** on page 22 and to your separate component manuals.

2. When applying the fluid, keep the gun a consistent distance, about 8 to 12 inches (200 to 300 mm) from the surface of the object being sprayed. Always hold the gun at a right angle from the surface. Do not make an arc with the gun, as it causes an uneven coat of fluid. Use a full-open, full-close triggering action. Practice to find the best length and speed of stroke.
3. To adjust the spray pattern, follow the instructions in your gun manual, supplied.
4. With the pump and lines primed, and with adequate air pressure and volume supplied, the pump will start and stop as you open and close the gun.

CAUTION

Do not allow the pump to run dry. It will quickly accelerate to a high speed, causing damage. If your pump is running too fast, stop it immediately and check the fluid supply. If the container is empty and air has been pumped into the lines, refill the container and prime the pump and the lines, or flush and leave it filled with a compatible solvent. Eliminate all air from the fluid system.

Shutdown and Care of the Pump

WARNING

To reduce the risk of serious injury whenever you are instructed to relieve pressure, always follow the **Pressure Relief Procedure** on page 10.

For overnight shutdown, stop the pump at the bottom of its stroke to prevent fluid from drying on the exposed displacement rod and damaging the throat packings. Shut off the agitator (39), if present. Relieve the pressure.

Always flush the pump before the fluid dries on the displacement rod. See **Flushing** on page 13.

Maintenance

Preventive Maintenance Schedule

The operating conditions of your particular system determine how often maintenance is required. Establish a preventive maintenance schedule by recording when and what kind of maintenance is needed, and then determine a regular schedule for checking your system.

Clean the In-Line Fluid Filter Element

The filter/swivel (104) includes a 100 mesh stainless steel filter element (105). Clean the element periodically with a compatible solvent, as follows.

WARNING

To reduce the risk of serious injury whenever you are instructed to relieve pressure, always follow the **Pressure Relief Procedure** on page 10.

1. Relieve the pressure.
2. Disassemble the filter/swivel (104) and remove the filter element (105).
3. Clean or replace the element, as necessary.
4. Reassemble. Torque the two halves of the filter/swivel to 10–15 ft-lb (14–20 N•m).

Flushing

WARNING

 **FIRE AND EXPLOSION HAZARD**
Before flushing, read the section **FIRE AND EXPLOSION HAZARD** on page 5. Be sure the entire system and flushing pails are properly grounded. Refer to **Grounding** on page 7.

Flush the pump:

- Before the first use
- When changing colors or fluids
- Before fluid can dry or settle out in a dormant pump (check the pot life of catalyzed fluids)
- Before storing the pump.

Flush with a fluid that is compatible with the fluid you are pumping and with the wetted parts in your system. Check with your fluid manufacturer or supplier for recommended flushing fluids and flushing frequency.

CAUTION

If you have a carbon steel package, never leave water or water-base fluid in the pump overnight. If you are pumping water-base fluid, flush with water first, then with a rust inhibitor such as mineral spirits. Relieve the pressure, but leave the rust inhibitor in the pump to protect the parts from corrosion.

WARNING

To reduce the risk of serious injury whenever you are instructed to relieve pressure, always follow the **Pressure Relief Procedure** on page 10.

1. Relieve the pressure.
2. Remove the tip guard and spray tip from the gun. See the gun manual.
3. Remove the filter element from the fluid filter (13). Reinstall the filter bowl.
4. Remove the strainer (42). Place the pump inlet in a container of solvent.
5. Hold a metal part of the gun firmly to the side of a grounded *metal* pail.
6. Start the agitator and run it slowly.
7. Start the pump. Always use the lowest possible fluid pressure when flushing.
8. Trigger the gun. Flush the system until clear solvent flows from the gun.
9. Relieve the pressure.
10. Clean the tip guard, spray tip, strainer, and fluid filter element separately, then reinstall them.

Parts

23:1 Monark Carbon Steel Packages, Part Nos. 232439, 232440, and 232443

23:1 Monark Stainless Steel Packages, Part Nos. 232451, 232452, and 232455

NOTE: Refer to page 16 for 10:1 and 15:1 Monark Packages.

NOTE: Some packages include a hose and gun. Refer to page 19 for details.

NOTE: To find the part number used in your package, read down the chart to find the desired ref. no., then read left to right to find the part number for your package.

| Ref. No. | Description | Packages | | | | Qty |
|----------|-----------------------------------------------------------------------------------|--------------------------|-------------------|--------------------------|-------------------|-----|
| | | CST 232439, 232440 | CST 232443 | SST 232451, 232452 | SST 232455 | |
| 1 | COVER, pail | 240435 | 240435 | 240435 | 240435 | 1 |
| 2 | PUMP, 23:1 Monark; cst; <i>see manual 307619</i> | 223596 | 223596 | | | 1 |
| | PUMP, 23:1 Monark; sst; <i>see manual 307619</i> | | | 237958 | 237958 | 1 |
| 3 | CAPSCREW, hex hd; 1/4–20 x 3/4 in. (19 mm) | 100644 | 100644 | 100644 | 100644 | 2 |
| 4 | LOCKWASHER; 1/4 in. | 100016 | 100016 | 100016 | 100016 | 2 |
| 5 | ELBOW, 90°; cst; 3/8 npt(m) x 3/8 npt(f) | 155699 | 155699 | | | 1 |
| | ELBOW, 90°; sst; 3/8 npt(m) x 3/8 JIC | | | 114484 | 114484 | 1 |
| 6 | ADAPTER; cst; 3/8 npt x 9/16–18 unf–2a | 114337 | 114337 | Not used | Not used | 1 |
| 7 | TUBE, flare; sst; 9/16–18 unf–2a x 3/8 in. (10 mm) OD | 114478 | 114478 | | | 1 |
| | TUBE, flare; sst; 9/16–18 unf–2a x 3/8 in. (10 mm) OD | | | 114477 | 114477 | 1 |
| 8 | FITTING, bulkhead | 192889 | 192889 | 192889 | 192889 | 1 |
| 9 | WASHER, flat; 9/16 in. | 114830 | 114830 | 114830 | 114830 | 1 |
| 10 | NUT, hex; 9/16–18 | 102300 | 102300 | 102300 | 102300 | 1 |
| 11 | NIPPLE; cst; 3/8 npt | 156849 | 156849 | | | 1 |
| | NIPPLE; sst; 3/8 npt | | | 166469 | 166469 | 1 |
| 12 | UNION, swivel, straight; cst; 3/8 npt(m) x 3/8 npsm(f) | 155665 | 155665 | | | 1 |
| | UNION, swivel, straight; sst; 3/8 npt(m) x 3/8 npsm(f) | | | 235208 | 235208 | 1 |
| 13 | FLUID FILTER; cst; <i>see manual 307273</i> | 239060 | 239060 | | | 1 |
| | FLUID FILTER; sst; <i>see manual 307273</i> | | | 239063 | 239063 | 1 |
| 14 | TEE; 3/8 npt(f) run x 3/8 npt(m) branch | 113777 | 113777 | 113777 | 113777 | 1 |
| 15 | VALVE, relief; 125 psi (0.86 MPa, 8.6 bar) | 113769 | 113769 | 113769 | 113769 | 1 |
| 16 | CONNECTOR, tube fitting; 3/8 npt(m) x 1/2 in. (13 mm) OD tube | 114129 | 114129 | 114129 | 114129 | 1 |
| 17 | TUBE; polyurethane; 1/2 in. (13 mm) OD; 1.3 ft (0.4 m) long | Obtain locally | Obtain locally | Obtain locally | Obtain locally | 1 |
| 18 | PUMP GROUND WIRE AND CLAMP | 238909 | 238909 | 238909 | 238909 | 1 |
| 19 | PAIL; 5 gallon (19 liter) | 101108 | 101108 | 101108 | 101108 | 1 |
| 20 | KNOB, screw; 1/4–20 | 114371 | 114371 | 114371 | 114371 | 3 |
| 21 | AIR REGULATOR KIT; <i>see manual 308686</i> | 240446 | 240446 | 240446 | 240446 | 1 |
| 22 | SCREW, socket; M5 x 0.8; 20 mm (3/4 in.) | 115439 | 115439 | 115439 | 115439 | 4 |
| 23 | NUT, hex, self-locking; M5 x 0.8 | 105332 | 105332 | 105332 | 105332 | 4 |
| 24 | QUICK CONNECTOR, elbow, 90°, tube; 1/8 npt(m) x 1/4 in. (6 mm) OD tube; acetal | Not used | 114367 | Not used | 114367 | 1 |
| 25 | WASHER, flat | 110874 | 110874 | 110874 | 110874 | 4 |

Parts

23:1 Monark Carbon Steel Packages, Part Nos. 232439, 232440, and 232443

23:1 Monark Stainless Steel Packages, Part Nos. 232451, 232452, and 232455

NOTE: Some packages include a hose and gun. Refer to page 19 for details.

NOTE: To find the part number used in your package, read down the chart to find the desired ref. no., then read left to right to find the part number for your package.

| Ref. No. | Description | Packages | | | | Qty |
|----------|---------------------------------------------------------------|--------------------------|----------------|--------------------------|----------------|-----|
| | | CST 232439, 232440 | CST 232443 | SST 232451, 232452 | SST 232455 | |
| 30 | SCREW, set; 1/4–20 x 1/4 in. (6 mm) | 101962 | 101962 | 101962 | 101962 | 2 |
| 31 | PLUG, pipe; 3/8 npt; not shown | 100040 | | 100040 | | 1 |
| | ELBOW, tube fitting, 90°; 3/8 npt(m) x 1/4 in. (6 mm) OD tube | | 114366 | | 114366 | 1 |
| 39 | PLUG, agitator; not shown | 114575 | | 114575 | | 1 |
| | AGITATOR; <i>see manual 306565</i> | | 224571 | | 224571 | 1 |
| 40 | AGITATOR GROUND WIRE | Not used | 240585 | Not used | 240585 | 1 |
| 41 | TUBE; nylon; 1/4 in. (6 mm) OD; 9.6 in. (244 mm) long | Not used | Obtain locally | Not used | Obtain locally | 1 |
| 42 | STRAINER, fluid inlet | 187190 | 187190 | 187190 | 187190 | 1 |

15:1 Monark Stainless Steel Packages, Part Nos. 232457, 232458, and 232461

15:1 Monark Carbon Steel Packages, Part Nos. 232463, 232464, and 232467

10:1 Monark Carbon Steel Packages, Part Nos. 232469, 232470, and 232473

NOTE: These packages all include a fluid regulator kit. Refer to page 18.

NOTE: Some packages include a hose and gun. Refer to page 19 for details.

NOTE: To find the part number used in your package, read down the chart to find the desired ref. no., then read left to right to find the part number for your package.

| Ref. No. | Description | Packages | | | | Qty |
|----------|-------------------------------------------------------|--------------------------|---------------|--------------------------|---------------|-----|
| | | SST 232457, 232458 | SST 232461 | CST 232463, 232464 | CST 232467 | |
| 1 | COVER, pail | 240435 | 240435 | 240435 | 240435 | 1 |
| 2 | PUMP, 15:1 Monark; sst; <i>see manual 308106</i> | 223844 | 223844 | | | 1 |
| | PUMP, 15:1 Monark; cst; <i>see manual 306981</i> | | | 239327 | 239327 | 1 |
| | PUMP, 10:1 Monark; cst; <i>see manual 307595</i> | | | | | 1 |
| 3 | CAPSCREW, hex hd; 1/4–20 x 3/4 in. (19 mm) | 100644 | 100644 | 100644 | 100644 | 2 |
| 4 | LOCKWASHER; 1/4 in. | 100016 | 100016 | 100016 | 100016 | 2 |
| 5 | ELBOW, 90°; cst; 3/8 npt(m) x 3/8 npt(f) | | | 155699 | 155699 | 1 |
| | ELBOW, 90°; sst; 3/8 npt(m) x 3/8 JIC | 114484 | 114484 | | | 1 |
| 6 | ADAPTER; cst; 3/8 npt x 9/16–18 unf–2a | Not used | Not used | 114337 | 114337 | 1 |
| 7 | TUBE, flare; sst; 9/16–18 unf–2a x 3/8 in. (10 mm) OD | | | 114478 | 114478 | 1 |
| | TUBE, flare; sst; 9/16–18 unf–2a x 3/8 in. (10 mm) OD | 114477 | 114477 | | | 1 |

Parts

15:1 Monark Stainless Steel Packages, Part Nos. 232457, 232458, and 232461

15:1 Monark Carbon Steel Packages, Part Nos. 232463, 232464, and 232467

NOTE: These packages all include a fluid regulator kit. Refer to page 18.

NOTE: Some packages include a hose and gun. Refer to page 19 for details.

NOTE: To find the part number used in your package, read down the chart to find the desired ref. no., then read left to right to find the part number for your package.

| Ref. No. | Description | Packages | | | | Qty |
|----------|-----------------------------------------------------------------------------------|--------------------------|-------------------|--------------------------|-------------------|-----|
| | | SST 232457, 232458 | SST 232461 | CST 232463, 232464 | CST 232467 | |
| 8 | FITTING, bulkhead | 192889 | 192889 | 192889 | 192889 | 1 |
| 9 | WASHER, flat; 9/16 in. | 114830 | 114830 | 114830 | 114830 | 1 |
| 10 | NUT, hex; 9/16–18 | 102300 | 102300 | 102300 | 102300 | 1 |
| 11 | NIPPLE; cst; 3/8 npt | | | 156849 | 156849 | 1 |
| | NIPPLE; sst; 3/8 npt | 166469 | 166469 | | | 1 |
| 12 | UNION, swivel, straight; cst; 3/8 npt(m) x 3/8 npsm(f) | | | 155665 | 155665 | 1 |
| | UNION, swivel, straight; sst; 3/8 npt(m) x 3/8 npsm(f) | 235208 | 235208 | | | 1 |
| 13 | FLUID FILTER; cst; <i>see manual 307273</i> | | | 239060 | 239060 | 1 |
| | FLUID FILTER; sst; <i>see manual 307273</i> | 239063 | 239063 | | | 1 |
| 14 | TEE; 3/8 npt(f) run x 3/8 npt(m) branch | 113777 | 113777 | 113777 | 113777 | 1 |
| 15 | VALVE, relief; 125 psi (0.86 MPa, 8.6 bar) | 113769 | 113769 | 113769 | 113769 | 1 |
| 16 | CONNECTOR, tube fitting; 3/8 npt(m) x 1/2 in. (13 mm) OD tube | 114129 | 114129 | 114129 | 114129 | 1 |
| 17 | TUBE; polyurethane; 1/2 in. (13 mm) OD; 1.3 ft (0.4 m) long | Obtain locally | Obtain locally | Obtain locally | Obtain locally | 1 |
| 18 | PUMP GROUND WIRE AND CLAMP | 238909 | 238909 | 238909 | 238909 | 1 |
| 19 | PAIL; 5 gallon (19 liter) | 101108 | 101108 | 101108 | 101108 | 1 |
| 20 | KNOB, screw; 1/4–20 | 114371 | 114371 | 114371 | 114371 | 3 |
| 21 | AIR REGULATOR KIT; <i>see manual 308686</i> | 240446 | 240446 | 240446 | 240446 | 1 |
| 22 | SCREW, socket; M5 x 0.8; 20 mm (3/4 in.) | 115439 | 115439 | 115439 | 115439 | 4 |
| 23 | NUT, hex, self-locking; M5 x 0.8 | 105332 | 105332 | 105332 | 105332 | 4 |
| 24 | QUICK CONNECTOR, elbow, 90°, tube; 1/8 npt(m) x 1/4 in. (6 mm) OD tube; acetal | Not used | 114367 | Not used | 114367 | 1 |
| 25 | WASHER, flat | 110874 | 110874 | 110874 | 110874 | 4 |
| 30 | SCREW, set; 1/4–20 x 1/4 in. (6 mm) | 101962 | 101962 | 101962 | 101962 | 2 |
| 31 | PLUG, pipe; 3/8 npt; not shown | 100040 | | 100040 | | 1 |
| | ELBOW, tube fitting, 90°; 3/8 npt(m) x 1/4 in. (6 mm) OD tube | | 114366 | | 114366 | 1 |
| 39 | PLUG, agitator; not shown | 114575 | | 114575 | | 1 |
| | AGITATOR; <i>see manual 306565</i> | | 224571 | | 224571 | 1 |
| 40 | AGITATOR GROUND WIRE | Not used | 240585 | Not used | 240585 | 1 |
| 41 | TUBE; nylon; 1/4 in. (6 mm) OD; 9.6 in. (244 mm) long | Not used | Obtain locally | Not used | Obtain locally | 1 |
| 42 | STRAINER, fluid inlet | 187190 | 187190 | 187190 | 187190 | 1 |

Fluid Regulator Parts

15:1 Monark Stainless Steel Packages, Part Nos. 232457, 232458, and 232461

15:1 Monark Carbon Steel Packages, Part Nos. 232463, 232464, and 232467

NOTE: The following part numbers apply only to packages supplied with a fluid regulator. Part numbers vary by package. To find the part number used in your package, read down the chart to find the desired ref. no., then read left to right to find the part number for your package.

| Ref. No. | Description | Packages | | Qty |
|----------|---------------------------------------------------------|-------------------------------------|--------------------------------------|-----|
| | | SST 232457, 232458, 232461 | CST 232463, 232464, 232467, | |
| 201 | FLUID PRESSURE REGULATOR; sst; <i>see manual 307886</i> | 222121 | 222121 | 1 |
| 202 | TEE; cst; 1/4 npt(m) x 1/4 npt(f) | | 108638 | 1 |
| | TEE; sst; 1/4 npt(m) x 1/4 npt(f) | 185281 | | 1 |
| 203 | GAUGE, pressure, fluid; cst | | 102814 | 1 |
| | GAUGE, pressure, fluid; sst | 112564 | | 1 |
| 204 | SWIVEL; cst; 1/4 npt x 1/4 npsm | | 162453 | 2 |
| | SWIVEL; sst; 1/4 npt x 1/4 npsm | 166846 | | 2 |
| 205 | BRACKET, mounting, fluid regulator | 193306 | 193306 | 1 |
| 206 | LOCKWASHER; 1/4 in. | 100016 | 100016 | 2 |
| 207 | CAPSCREW, hex hd; 1/4-20 x 5/8 in. (16 mm) | 100270 | 100270 | 2 |
| 208 | PLUG, pipe; 1/4 npt | 111697 | 111697 | 1 |

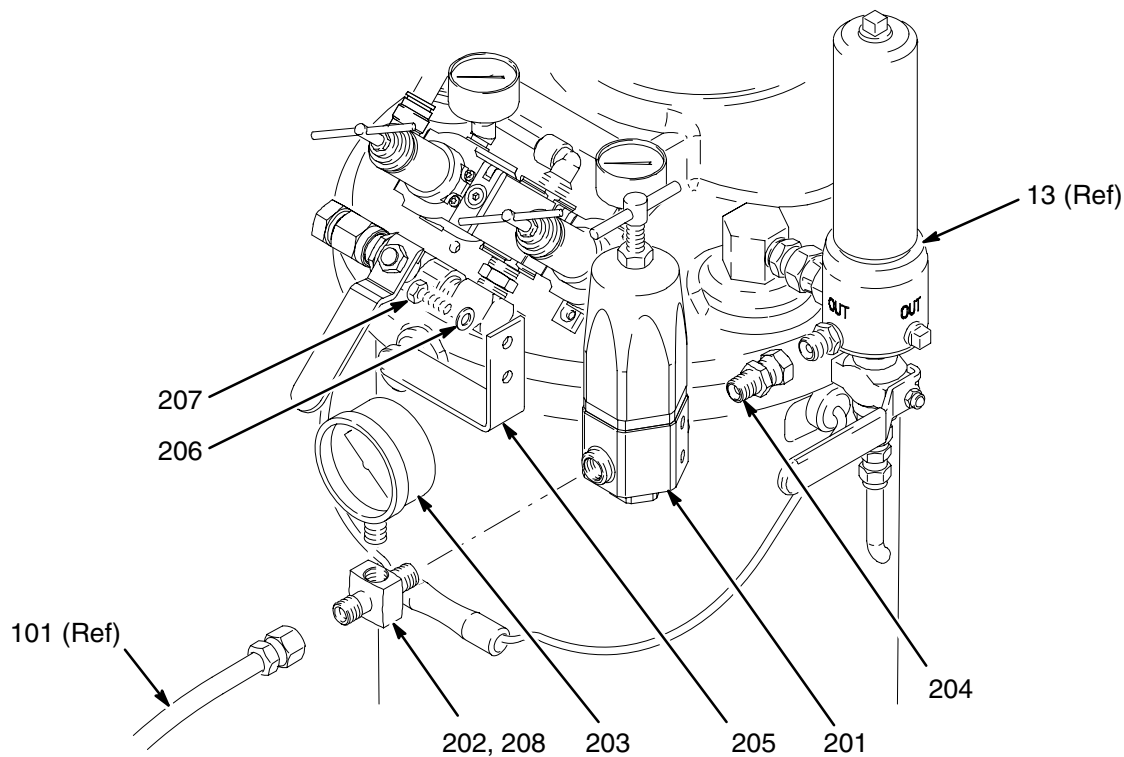

8236A

Hose and Gun Parts

23:1 Monark Carbon Steel Packages, Part Nos. 232439 and 232443

23:1 Monark Stainless Steel Packages, Part Nos. 232451 and 232455

15:1 Monark Stainless Steel Packages, Part Nos. 232457 and 232461

15:1 Monark Carbon Steel Packages, Part Nos. 232463 and 232467

NOTE: The following part numbers apply only to packages supplied with a hose and gun. Part numbers vary by package. To find the part number used in your package, read down the chart to find the desired ref. no., then read left to right to find the part number for your package.

| Ref. No. | Description | Packages | | Qty |
|----------|-----------------------------------------------------------------------------------------------------------|-------------------------------------------|------------------------------------------|-----|
| | | CST 232439, 232443, 232463, 232467, | SST 232451, 232455, 232457, 232461 | |
| 101 | HOSE, twin, air/fluid; nylon; cst fluid fittings; 1/4 npsm (fbe); 1/4 in. (6 mm) ID; 24.6 ft (7.5 m) long | 239102 | | 1 |
| | HOSE, twin, air/fluid; nylon; sst fluid fittings; 1/4 npsm (fbe); 1/4 in. (6 mm) ID; 24.6 ft (7.5 m) long | | 239074 | 1 |
| 102 | NIPPLE; cst; 1/4 npt x 1/4 npsm | 162453 | | 1 |
| | NIPPLE; sst; 1/4 npt x 1/4 npsm | | 166846 | 1 |
| 103 | HOSE, whip, fluid; nylon; cst fittings; 1/4 npsm (fbe); 3/16 in. (5 mm) ID; 23.6 in. (0.6 m) long | 238708 | | 1 |
| | HOSE, whip, fluid; nylon; sst fittings; 1/4 npsm (fbe); 3/16 in. (5 mm) ID; 23.6 in. (0.6 m) long | | 239069 | 1 |
| 104 | FILTER/SWIVEL, gun; includes replaceable item 105 | 239394 | 239394 | 1 |
| 105 | . ELEMENT, filter; 100 mesh sst; not shown | 205264 | 205264 | 1 |
| 106 | AA SERIES SPRAY GUN; with AAM413 tip; <i>see manual 311001</i> | 249242 | 249242 | 1 |
| 107 | SPRAY TIP; customer's choice; not shown | AAMxxx | AAMxxx | 1 |

Dimensions

*Model 232439 Shown
(hose and gun not shown)*

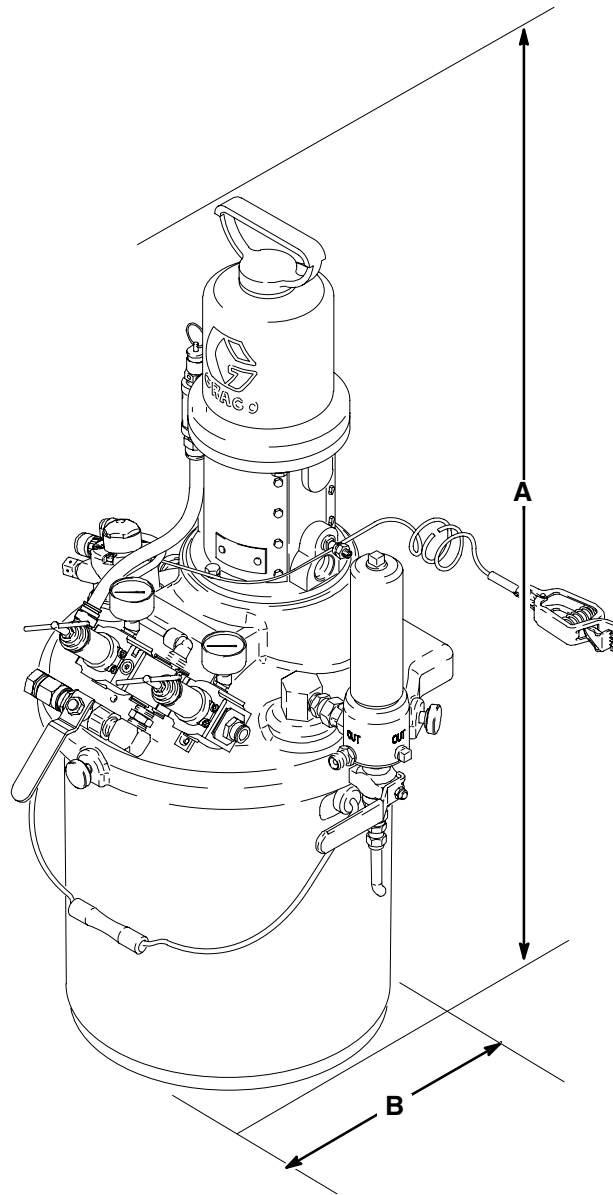

8164A

| A (height) | B (diameter of pail) | Weight |
|-----------------|----------------------|---------------|
| 32 in. (813 mm) | 10.625 in. (270 mm) | 47 lb (21 kg) |

Technical Data

| Category | Data |
|--------------------------------|--------------------------------------------------------------------------------------------------------------------------------------------------------------------------------------------------------------------------------------------------------------------------------------------------------|
| Maximum fluid working pressure | <i>Part Nos. 232439, 232440, 232443, 232451, 232452, 232455:</i> 2300 psi (16 MPa, 160 bar) <i>Part Nos. 232457, 232458, 232461, 232463, 232464, 232467:</i> |
| Maximum air input pressure | 100 psi (0.7 MPa, 7 bar) |
| Maximum gun air input pressure | 100 psi (0.7 MPa, 7 bar) |
| Ratio | <i>Part Nos. 232439, 232440, 232443, 232451, 232452, 232455:</i> 23:1 <i>Part Nos. 232457, 232458, 232461, 232463, 232464, 232467:</i> 15:1 |
| Maximum operating temperature | 120°F (50°C) |
| Wetted parts | <i>Pump:</i> See applicable pump manual <i>Spray Gun:</i> See gun manual 311001 <i>Fluid Filter:</i> See filter manual 307273 <i>Agitator (if present):</i> See agitator manual 306565 <i>Fluid Regulator (if present):</i> See fluid regulator manual 307886 <i>Fluid Hoses:</i> Nylon |

Sound Pressure Levels (dBa)

(measured at 1 meter from unit)

| Air Motor | Input Air Pressures at 15 cycles per minute | | |
|-----------|---------------------------------------------|----------------------------|--------------------------|
| | 40 psi (0.28 MPa, 2.8 bar) | 70 psi (0.48 MPa, 4.8 bar) | 100 psi (0.7 MPa, 7 bar) |
| Monark | 73.3 dB(A) | 75.9 dB(A) | 77.7 dB(A) |

Sound Power Levels (dBa)

(tested in accordance with ISO 9614–2)

| Air Motor | Input Air Pressures at 15 cycles per minute | | |
|-----------|---------------------------------------------|----------------------------|--------------------------|
| | 40 psi (0.28 MPa, 2.8 bar) | 70 psi (0.48 MPa, 4.8 bar) | 100 psi (0.7 MPa, 7 bar) |
| Monark | 87.0 dB(A) | 89.7 dB(A) | 91.4 dB(A) |

Technical Data

Performance Charts

To find Fluid Outlet Pressure (psi/MPa/bar) at a specific fluid flow (lpm/gpm) and operating air pressure (psi/MPa/bar):

1. Locate desired flow along bottom of chart.
2. Follow vertical line up to intersection with selected fluid outlet pressure curve (black). Follow left to scale to read fluid outlet pressure.

To find Pump Air Consumption (m³/min or scfm) at a specific fluid flow (lpm/gpm) and air pressure (psi/MPa/bar):

1. Locate desired flow along bottom of chart.
2. Read vertical line up to intersection with selected air consumption curve (dashes). Follow left to scale to read air consumption.

- A 100 psi (0.7 MPa, 7 bar) air pressure (95 psi on 10:1 Monark)
- B 70 psi (0.49 MPa, 4.9 bar) air pressure
- C 40 psi (0.28 MPa, 2.8 bar) air pressure

Monark 23:1 Fluid Outlet Pressure

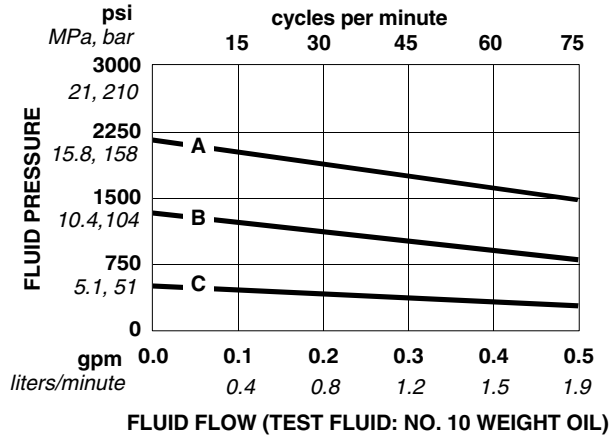

Monark 23:1 Air Consumption

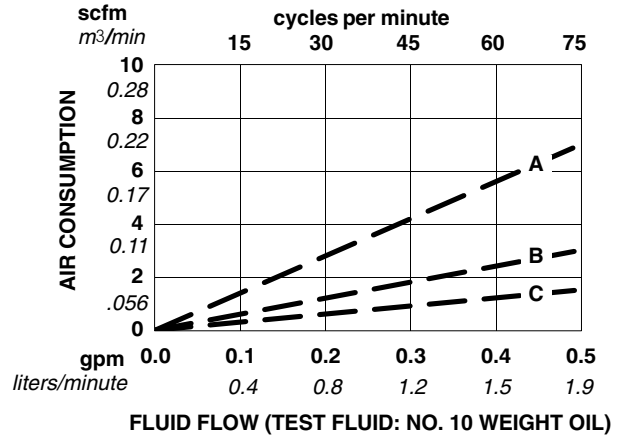

Monark 15:1 Fluid Outlet Pressure

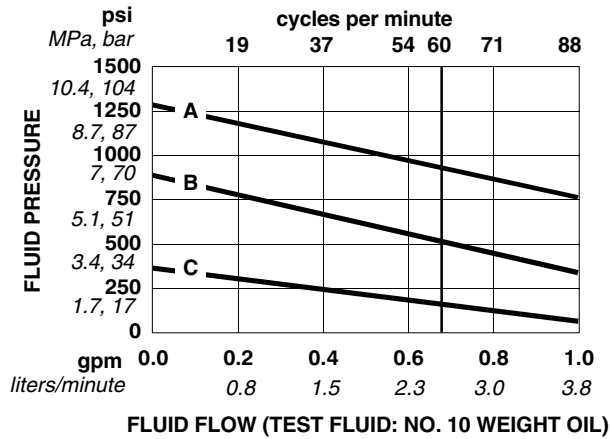

Monark 15:1 Air Consumption

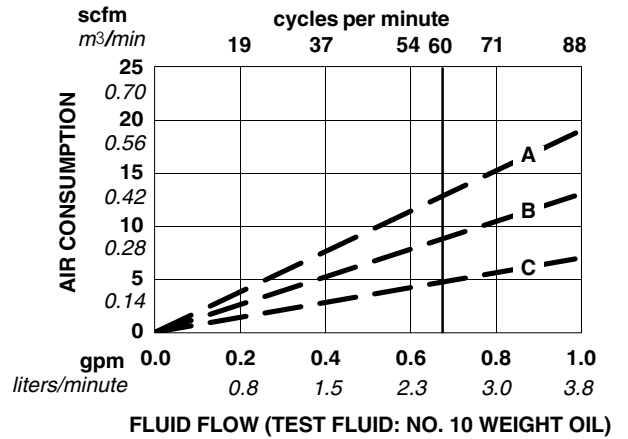

Graco Standard Warranty

Graco warrants all equipment manufactured by Graco and bearing its name to be free from defects in material and workmanship on the date of sale to the original purchaser for use. With the exception of any special, extended, or limited warranty published by Graco, Graco will, for a period of twelve months from the date of sale, repair or replace any part of the equipment determined by Graco to be defective. This warranty applies only when the equipment is installed, operated and maintained in accordance with Graco's written recommendations.

This warranty does not cover, and Graco shall not be liable for general wear and tear, or any malfunction, damage or wear caused by faulty installation, misapplication, abrasion, corrosion, inadequate or improper maintenance, negligence, accident, tampering, or substitution of non-Graco component parts. Nor shall Graco be liable for malfunction, damage or wear caused by the incompatibility of Graco equipment with structures, accessories, equipment or materials not supplied by Graco, or the improper design, manufacture, installation, operation or maintenance of structures, accessories, equipment or materials not supplied by Graco.

This warranty is conditioned upon the prepaid return of the equipment claimed to be defective to an authorized Graco distributor for verification of the claimed defect. If the claimed defect is verified, Graco will repair or replace free of charge any defective parts. The equipment will be returned to the original purchaser transportation prepaid. If inspection of the equipment does not disclose any defect in material or workmanship, repairs will be made at a reasonable charge, which charges may include the costs of parts, labor, and transportation.

THIS WARRANTY IS EXCLUSIVE, AND IS IN LIEU OF ANY OTHER WARRANTIES, EXPRESS OR IMPLIED, INCLUDING BUT NOT LIMITED TO WARRANTY OF MERCHANTABILITY OR WARRANTY OF FITNESS FOR A PARTICULAR PURPOSE.

Graco's sole obligation and buyer's sole remedy for any breach of warranty shall be as set forth above. The buyer agrees that no other remedy (including, but not limited to, incidental or consequential damages for lost profits, lost sales, injury to person or property, or any other incidental or consequential loss) shall be available. Any action for breach of warranty must be brought within two (2) years of the date of sale.

Graco makes no warranty, and disclaims all implied warranties of merchantability and fitness for a particular purpose in connection with accessories, equipment, materials or components sold but not manufactured by Graco. These items sold, but not manufactured by Graco (such as electric motors, switches, hose, etc.), are subject to the warranty, if any, of their manufacturer. Graco will provide purchaser with reasonable assistance in making any claim for breach of these warranties.

In no event will Graco be liable for indirect, incidental, special or consequential damages resulting from Graco supplying equipment hereunder, or the furnishing, performance, or use of any products or other goods sold hereto, whether due to a breach of contract, breach of warranty, the negligence of Graco, or otherwise.

FOR GRACO CANADA CUSTOMERS

The parties acknowledge that they have required that the present document, as well as all documents, notices and legal proceedings entered into, given or instituted pursuant hereto or relating directly or indirectly hereto, be drawn up in English. Les parties reconnaissent avoir convenu que la rédaction du présente document sera en Anglais, ainsi que tous documents, avis et procédures judiciaires exécutés, donnés ou intentés à la suite de ou en rapport, directement ou indirectement, avec les procédures concernées.

Graco Information

TO PLACE AN ORDER, contact your Graco distributor, or call one of the following numbers to identify the distributor closest to you:

1-800-328-0211 Toll Free

612-623-6921

612-378-3505 Fax

All written and visual data contained in this document reflects the latest product information available at the time of publication.

Graco reserves the right to make changes at any time without notice.

MM 308766

Graco Headquarters: Minneapolis
International Offices: Belgium, China, Japan, Korea

www.graco.com

PRINTED IN USA 308766 05/1999, Revised 07/2005