



GRACO® E-XTREME® EX45 ELECTRIC AIRLESS SPRAY PUMP



PART NUMBERS AND SCHEMATICS GUIDE

Company Profile

Since 1944, Marco has developed a strong tradition of providing innovative and reliable products and services to the surface preparation and protective coatings industries. We are the world's premier provider of Abrasives, Blasting Equipment, Coating Equipment, Engineered Systems, Rental Equipment, Safety Equipment, Service, and Repair.

Through innovative designs and a total commitment to quality, Marco manufactures products that increase production rates, create a safer workplace, and reduce maintenance costs. Marco's industry experience, manufacturing capabilities, legendary customer service, product availability, logistics services, and technology leadership is your assurance that we deliver high quality products and services, providing the best value to you, our customer.

The Marco Difference

- **Industry Experience** – With Marco on your team, you have access to expertise which can only come from decades of industry leadership. We have organized our engineering department, production specialists, customer operations, and safety support into a “Center of Competence.” As a Marco customer, you have access to hundreds of years of cumulative experience related to your operations.
- **Manufacturing Excellence** – Marco is a U.S. based, ISO 9001:2008 certified manufacturer of equipment for the Surface Preparation and Protective Coatings industries. Marco's engineers benchmark the industry to ensure that we design and manufacture superior products that set the “Gold Standard” for performance, safety, and quality.
- **Legendary Customer Service** – Marco's legendary customer service team is staffed by friendly, highly-trained individuals who are focused on providing the highest level of product support, order accuracy, and customer satisfaction.
- **Product Availability** – We stock over 10,000 SKU's and have over 45 shipping locations to serve North American and International markets for all major brands of blasting and painting equipment. As the largest provider of surface preparation and protective coatings equipment in the world, our inventory levels and product availability are unmatched.
- **Logistics Services** – Marco's in-house logistics team is dedicated to moving your shipment anywhere in the world. We move over 14,000 truckloads every year, allowing you to save on freight costs by leveraging our buying power. Lower your process costs with a single invoice, which includes product and freight.
- **Technology Leadership** – Our website provides: Operator's Manuals, Part Numbers and Schematics Guides, MSDS information, and Features and Specifications Guides, providing access to information 24/7. Our Extranet application allows you to receive quotes and place orders online. Our Intranet maintains a complete record of your purchase history to assist with ongoing support of your existing equipment and future purchasing decisions.

Vision Statement

Marco is the world's premier provider of Abrasives, Blasting Equipment, Coating Equipment, Engineered Systems, Rental Equipment, Safety Equipment, Service, and Repair.

Mission Statement

Marco provides strong leadership and innovation to the surface preparation and protective coatings industries. We dedicate our efforts to the continuous improvement of our products, services, processes, people, and most importantly, the quality of our customer's experience.

Quality Policy

Marco is committed to providing superior quality in the design, manufacturing, distribution, rental, service, and repair of our products. Our ISO 9001:2008 certification extends throughout all operations in all locations. Continuous improvement of our processes and supply chain Integration comprise the core of our business strategy for delivering exceptional quality and value in all Marco products and services.

Management Philosophy

We are a company dedicated to the success of every customer and associate. We discuss, debate, challenge, measure, and test our ideas. We will be boundless and limitless in our passion to improve. Through sound leadership and dedicated associates, we will ensure a long term, profitable future for Marco, our associates, customers, and suppliers.

TABLE OF CONTENTS

Company Profile	2
Table of Contents	3
Graco® e-Xtreme® Ex45	
Electric Airless Spray Pumps	4-14
Part Numbers	4-5
Graco® e-Xtreme® Ex45	6-7
Graco® e-Xtreme® Driver	8-9
145cc e-Xtreme® Lower Displacement Pumps .	10-11
Xtreme® Seals Repair Kit	12-13
Outlet Check Valves	14
Optional Accessories	15-16
Spraymaster® 10 Gallon Pump Hopper	15
Suction Tubes and Accessories	16
Replacement Screen Filter Elements	16
Filter Supports	16
Maintenance Notes	17-19

PART NUMBERS AND SCHEMATICS GUIDE

GRACO® E-XTREME® EX45 ELECTRIC AIRLESS SPRAY PUMPS						
Part Numbers	MOUNT		Integrated Filter	Hopper	Hose and Graco® XTR™ 5 Spray Gun Included	Lower Pump
	Cart Mount	Wall Mount				
20G24Y905	X		X	X	X	145 cc
20G24Y906	X		X	X		145 cc
20G24Y901	X		X		X	145 cc
20G24Y902	X		X			145 cc
20G24Y907	X			X	X	145 cc
20G24Y908	X			X		145 cc
20G24Y903	X				X	145 cc
20G24Y904	X					145 cc
20G24Y909		X	X		X	145 cc
20G24Y910		X	X			145 cc
20G24Y911		X			X	145 cc
20G24Y912		X				145 cc

GRACO® E-XTREME® EX45 ELECTRIC AIRLESS SPRAY PUMPS – SPECIFICATIONS

Maximum Fluid Working Pressure	4500 psi
Pump Lower	145 cc
Maximum Continuous Cycle Rate	44 Cycles/min
Weight	295 lbs.
Operating Temperature Range	23° to 120° F
Oil Capacity	1.0-1.2 quarts
Input Voltage	200 – 240-Volt AC, single phase, 50/60 Hz

PART NUMBERS AND SCHEMATICS GUIDE



PART NUMBERS AND SCHEMATICS GUIDE

Graco® e-Xtreme® Ex45 Electric Airless Spray Pump

Item #	Part #	Description	Item #	Part #	Description
Fig. 1			81	20G17D554	Upper Bracket Hopper
1	20G255143	Wall Mounted Bracket <i>(Includes Item #'s: 5 and 6)</i>	82	20G17C474	Hopper Bracket
	20G24Y078	Heavy Duty Cart <i>(Includes Item #'s: 14, 20, 21 and 22)</i>	83	20G112395	Flanged Cap Screw <i>(Quantity of Four)</i>
4	20G24X901	e-Xtreme® Driver <i>(Includes Item #31) (See Fig. 2)</i>	84	20G16U537	Complete Cover
5	20G100133	3/8" Lockwasher Spring <i>(Quantity of Four)</i>	85	20G17E114	Xtreme® Weldment Hopper
6	20G100101	3/8-16 x 1" Long Screw <i>(Quantity of Four)</i>	86	20G120307	Male Hose Adapter Fitting
7	20G15H392	Xtreme® Rod Adapter	87	20G120308	Female Hose Adapter Fitting
8	20G257150	14-1/4" Long – Tie Rod <i>(Quantity of Three)</i>	87a	20G120781	Quick Coupler Gasket (PTFE)
9	20GL145CN	145cc Xtreme® Lower without Integrated Filter <i>(See Fig. 3)</i>	87b	20G17C453	Quick Coupler Gasket (Buna-N 6-Pack) <i>(Not Shown)</i>
	20GL145CL	145cc Xtreme® Lower with Integrated Filter <i>(See Fig. 3)</i>	88	20G17L152	Swivel Fitting
9a	20G258962	Rupture Disc Housing Assembly	89	20G112958	Flanged Hex Nut <i>(Quantity of Four)</i>
10	20G101712	Lock Nut <i>(Quantity of Three)</i>	101	20G17J476	Warning Label
11	20G244820	Connector Clip with Lanyard	—	20G25C188	Hopper Accessory Kit <i>(Includes Item #'s: 17, 71, 81, 82, 83, 84, 85, 86, 87, 87a, 87b, 88, and 89)</i>
12	20G244819	Xtreme® Rod Quick Coupling	—	201V626	Brochure – Graco® e-Xtreme® Electric Airless Spray Pumps
13	20G197340	Coupler Cover	—	206M627	Part Numbers & Schematics Guide – Graco® e-Xtreme® Ex45 Electric Airless Spray Pumps
14	20G113361	Round Tube Cap <i>(Quantity of Two)</i>	—	206M626	Part Numbers & Schematics Guide – Graco® XTR™ 5 Airless Spray Gun
17	20G17L151	Elbow Fitting	—	209V626	Operator's Manual – Graco® e-Xtreme® Electric Airless Spray Pumps
20	20G113362	Wheel <i>(Quantity of Two)</i>			
21	20G154628	Washer <i>(Quantity of Two)</i>			
22	20G113436	Retaining Ring <i>(Quantity of Two)</i>			
24	20G116746	Plated Barbed Fitting			
25	20G116750	Nylon Tube			
31	20G16W645	1 qt. Gear Oil <i>(Quantity of Two)</i>			
41	20G206994	Throat Seal Liquid – 8 oz.			
44a	2000027	1/4" x 6' Coupled Hose 5000 psi			
44b	20G164856	3/8" x 1/4" Nipple Fitting			
44c	2000050	3/8" x 50' Coupled Hose 4500 psi			
47	20GXTR504	XTR™ 5 Airless Paint Gun			
55	20G25C189	Subassembly Valve <i>(For models with no filters)</i>			
	20G127631	Subassembly Valve <i>(For models with integrated filters)</i>			
55a	20G245143	Bleed Off Valve <i>(See Fig. 5)</i>			
58	20G17A411	Instructions Label			
64	20G162505	3/8" (M) x 1/2" (F) Adapter			
71	20GC19024	Swivel Elbow Fitting			
74	20G24Z274	1" x 3' Suction Hose			

PART NUMBERS AND SCHEMATICS GUIDE

Graco® e-Xtreme® Driver

Item #	Part #	Description
Fig. 2		
—	20G24X901	Graco® e-Xtreme® Driver
1	—	Driver Housing
3	20G116343	Grounding Clamp (<i>Quantity of Three</i>)
9	20G15F931	Lift Ring
13	20G15H525	Oil Fill Cap
14	20G24E315	Sight Glass
19	20G25C164	Output Seal Cartridge
19a	20G25C162	Support Washer Kit
19b	20G25C163	Lower Bumper Kit
19c	20G25C165	O-Ring (<i>Pack of Two</i>)
20	20G25C161	3/8" Plug Kit
24	—	Socket Head Cap Screw (<i>Quantity of 28</i>)
25	20G15H432	Oil Drain Plug
27	20G25C172	Electrical Junction Box Cover
27a	20G123970	40A Disconnect Switch
33	20G16T764	Warning Label
34	20G17J476	Warning Label
36	20G16U113	Knob Kit
43	—	Spring Lockwasher (<i>Quantity of 32</i>)
44	20G16U979	Torque Specifications Label
45	20G25C171	Junction Box Housing Kit
46	20G25C170	1-1/4" Screw (<i>Quantity of Four</i>)
49	20G17M815	Fan Bearing with Coupler Kit
49a	—	Coupler
49b	20G25C182	Input Shaft Seal Kit
49c	20G119539	Internal Retaining Ring
51	20G25C181	Shroud Mount Bracket
51a	20G120668	Flat Head Screw
53	20G25C183	Fan Kit
53a	20G122347	External Retaining Ring
55	20G25C184	Shroud Cover Kit
55a	20G124165	Screw
106	20G17G768	Error Code Instruction Label
—	20G16W645	1 qt. Gear Oil (<i>Quantity of Two</i>)
—	209V571	Operator's Manual – Graco® e-Xtreme® Driver

PART NUMBERS AND SCHEMATICS GUIDE

Figure 2: Graco® e-Xtreme® Driver

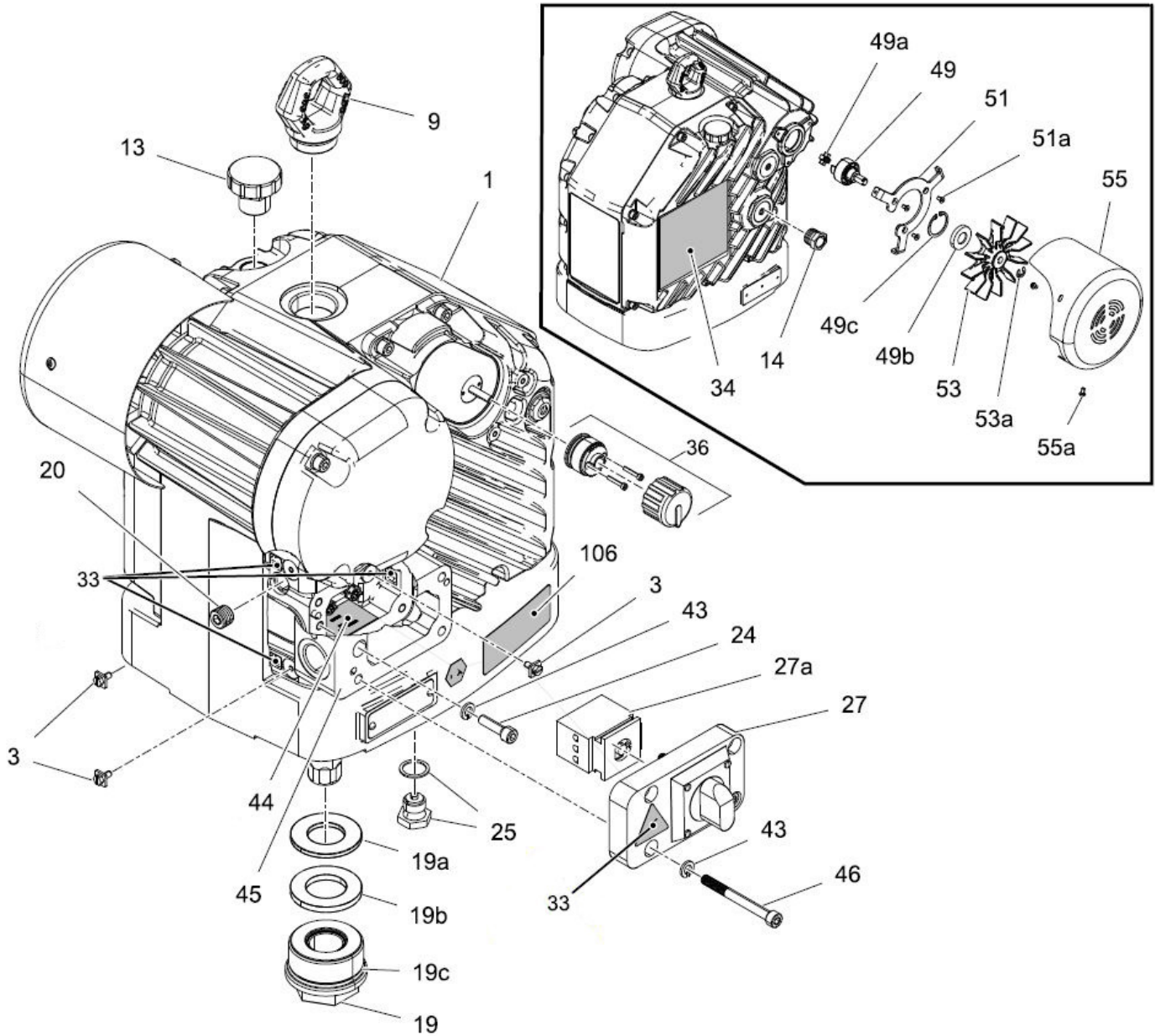

PART NUMBERS AND SCHEMATICS GUIDE

145cc e-Xtreme® Sprayer Lower Displacement Pump

Item #	20GL145CN (No Filter)	20GL145CL (Integrated Filter)	Description
Fig. 3			
1	20G24B821	20G24B821	Displacement Rod
2	20G15K030	20G15K030	Packing Nut
3	—	—	Stack Packings, Throat (See Repair Kit, Fig. 4)
4	—	—	Stack Packings, Piston (See Repair Kit, Fig. 4)
7	20G197325	20G197325	Packing Cartridge, Throat
8	20G197334	20G197336	Housing Outlet
9	20G244892	20G244892	O-Ring, Top Cylinder, PTFE Medium (Quantity of 10)
10	20G244826	20G244826	Self-Locking Pin
11	20G197315	20G197315	Lower Cylinder
12	20G253029	20G253029	Ball Piston (Quantity of Three)
13	20G24B826	20G24B826	Piston Valve
14	20G197303	20G197303	Inlet Housing
15	20G197307	20G197307	Inlet Ball Guide
16	20G245128	20G245128	Inlet Ball (Quantity of Three)
17	20G244855	20G244855	Inlet Shim Ball Guide (Quantity of Nine)
18	20G196358	20G196358	Inlet Seat
19	20G247394	20G247394	Throat Seal Plug (Quantity of 10)
20	—	20G16M461	Top Filler Cap
21	—	20G171941	Compression Spring
22	—	20G244895	Thin Filter O-Ring, PTFE (Quantity of 10)
23	—	20G224459	Strainer, 60 Mesh Screen
24	—	20G186075	Filter Support
25	—	20G262484	Filter O-Ring, Medium, PTFE (Quantity of 10)
26	—	20G16M462	Lower Filter Cap
27	20G244890	20G244890	Foot Valve and Cylinder Bottom O-Ring, PTFE Thin (Quantity of 10)
30	20G172479	20G172479	Warning Tag
32	20G244890	20G244890	Throat Cartridge O-Ring, PTFE Thin (Quantity of 10)
38	—	20G158491	Nipple Fitting, Outlet, 1/2"
39	—	20G24N518	Packless Plug, 1/2"
40	—	20G245143	Pressure Dump Valve
41	—	20G116746	Barbed Fitting, Plated
42	—	20G116750	Nylon Tube
49	20G101754	20G198292	Pipe Plug
55	20G127628	20G127628	Rupture Disc Housing
59	—	20G262483	Filter O-Ring, PTFE Thick (Quantity of 10)

PART NUMBERS AND SCHEMATICS GUIDE

Figure 3: 145cc e-Xtreme® Sprayer Lower Displacement Pump

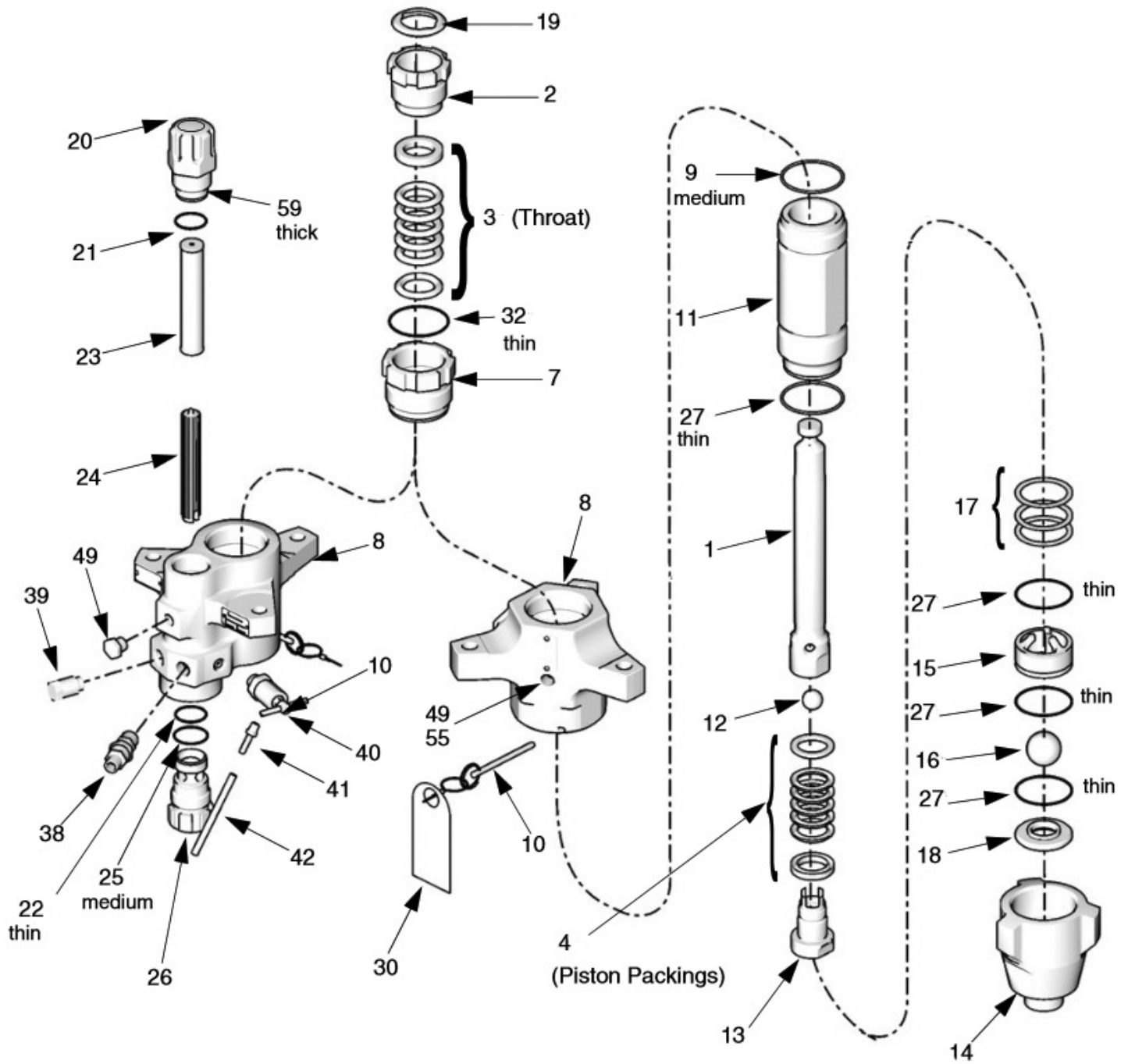

Note: Lower Displacement Pump with Integrated Filter Shown

PART NUMBERS AND SCHEMATICS GUIDE

Xtreme® Seals Repair Kit for 145cc Lower Displacement Pump

Item #	Part #	Description
Fig. 4		
—	20G24F971	Xtreme® Seals Repair Kit for 145cc Lower Displacement Pump <i>(Includes Item #'s: 103, 104, 109, 112, 116, 119, 122, 125, 127, 143, and 159)</i>
103	—	Throat Packings
103a	20G244881	Male Gland <i>(Quantity of Four)</i>
103b	20G244875	Female Gland <i>(Quantity of Four)</i>
103c	20G244869	V-Packing, Leather <i>(Quantity of 10)</i>
103d	20G244863	V-Packing, UHMWPE <i>(Quantity of 10)</i>
104	—	Piston Packings
104a	20G244881	Male Gland <i>(Quantity of Four)</i>
104b	20G244875	Female Gland <i>(Quantity of Four)</i>
104c	20G244869	V-Packing, Leather <i>(Quantity of 10)</i>
104d	20G244863	V-Packing, UHMWPE <i>(Quantity of 10)</i>
109	20G244892	PTFE O-Ring, Top Cylinder Medium <i>(Quantity of 10)</i>
112	20G253029	Ball Piston, 3/4" (19 mm) <i>(Quantity of Three)</i>
116	20G245128	Ball Inlet, 1-1/4" (32 mm) <i>(Quantity of Three)</i>
117	20G244855	Shim Inlet, Ball Guide <i>(Quantity of Nine)</i>
119	20G244996	Throat Seal Plug, 1-3/4" <i>(Quantity of 10)</i>
—	20G247394	Throat Seal Plug, 2-1/2" <i>(Quantity of 10)</i>
122	20G244895	Filter O-Ring, Thin, PTFE <i>(Quantity of 10)</i>
123	20G238436	Strainer, 30 Mesh Screen, 5.65" <i>(Quantity of 25)</i>
—	20G224458	Strainer, 30 Mesh, 5.65" <i>(Quantity of Two)</i>
—	20G238438	Strainer, 60 Mesh, 5.65" <i>(Quantity of 25)</i>
—	20G224459	Strainer, 60 Mesh, 5.65" <i>(Quantity of Two)</i>
125	20G262484	Filter O-Ring, Medium, PTFE <i>(Quantity of 10)</i>
—	20G244896	Filter O-Ring For Series A Pumps <i>(Quantity of 10)</i>
127	20G244890	O-Ring, PTFE, Thin <i>(Quantity of 10)</i>
143	20G116801	Foot Valve Spring
159	20G262483	Top Cap O-Ring, PTFE <i>(Quantity of 10)</i>
—	20G244895	Top Cap O-Ring For Series A Pumps <i>(Quantity of 10)</i>
—	209V021	Operator's Manual – Graco® Xtreme® Pump Lowers

Quantities listed with repair kit are number of individual pieces.

PART NUMBERS AND SCHEMATICS GUIDE

Figure 4: Xtreme® Seals Repair Kit for 145cc Lower Displacement Pump

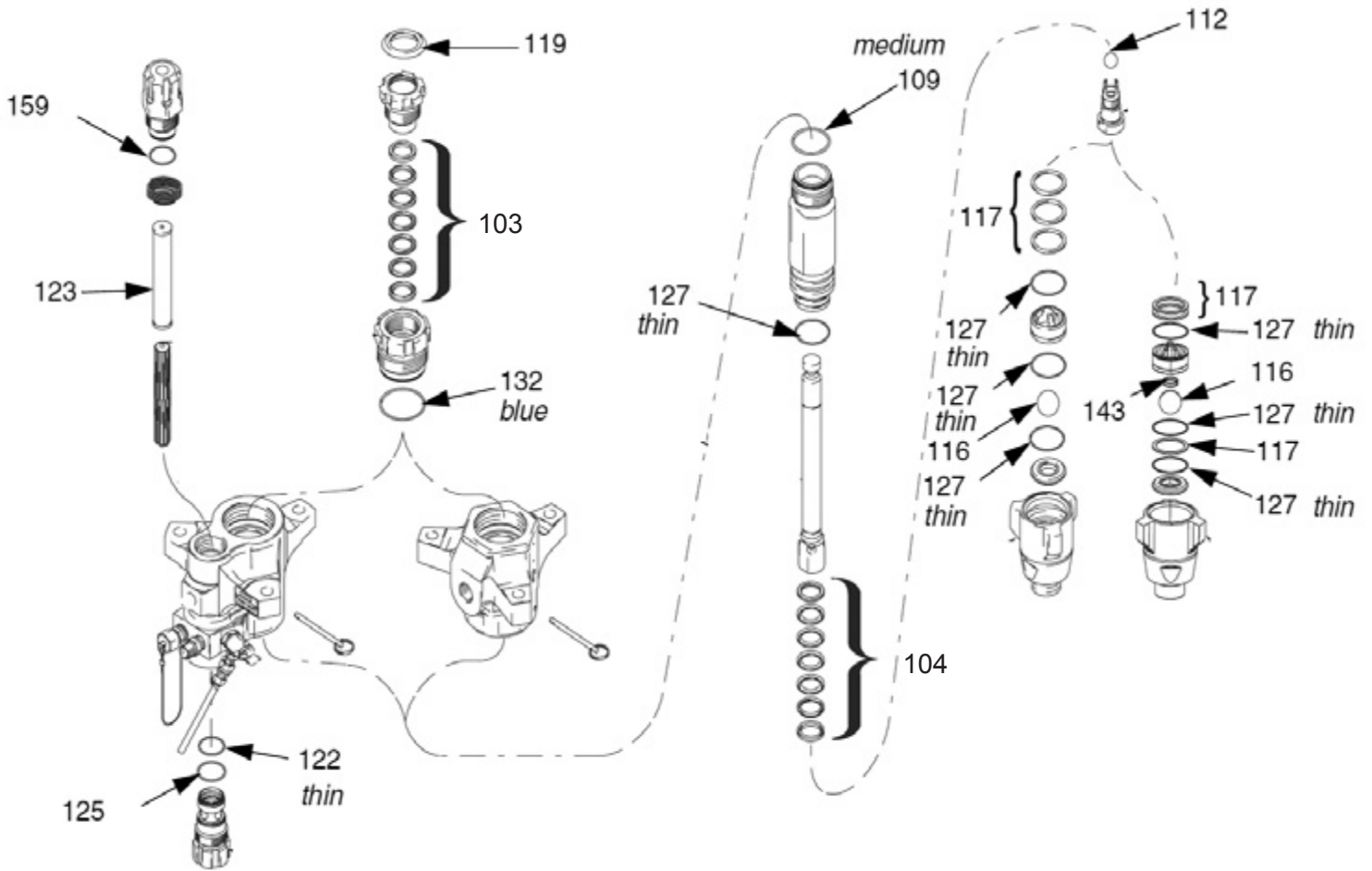

Xtreme® Seal Repair Kit

**Throat Packings:
Lips Face Down**

**Piston Packings:
Lips Face Up**

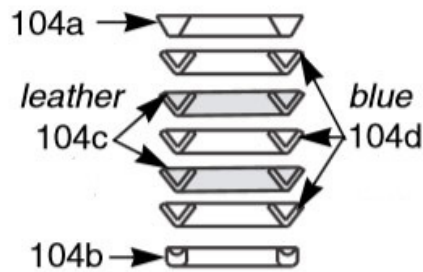
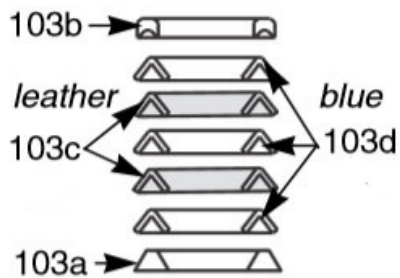

PART NUMBERS AND SCHEMATICS GUIDE

Figure 5: Outlet Check Valves

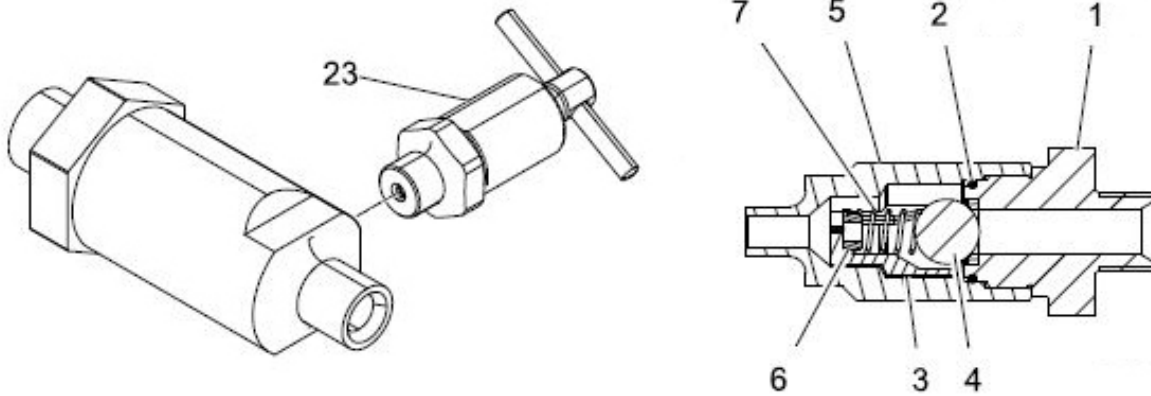

Item #	Part #	Description
--------	--------	-------------

Fig. 5

—	20G127631	Outlet Check Valve – 3/4" Male NPT Inlet
—	20G25C189	Outlet Check Valve – 1/2" Male NPT Inlet
1	20G127882	Seat Nut (Includes Item #'s: 2 and 4) (For model 20G127631)
—	20G25C190	Seat Nut (Includes Item #'s: 2 and 4) (For model 20G25C189)
2	20G102595	Packing O-Ring
3	20G181492	Ball Guide (Quantity of Three)
4	20G102971	Metallic Ball
5	20G17A091	Check Ball Housing
6	20G181535	Spring Retainer
7	20G108361	Compression Spring
23	20G245143	Bleed Off Valve



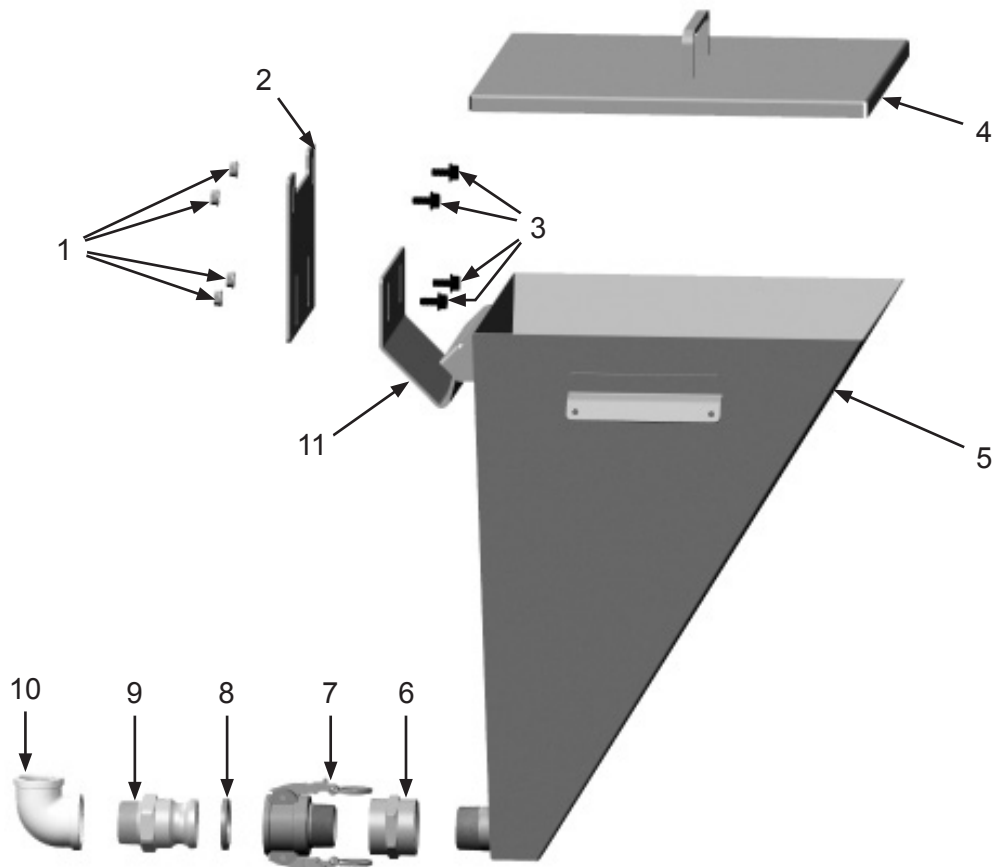

OPTIONAL ACCESSORIES

Figure 6: Spraymaster® 10 Gallon Pump Hopper



Item #	Part #	Description
Fig. 6		
—	20101239	Spraymaster® 10 Gallon Pump Hopper
1	20101259	3/8-16 Serrated Flange Nut – Zinc
2	20101245	10 Gallon Hopper Mounting Bracket
3	20101258	3/8-16 x 3/4" Serrated Screw
4	20100614	Lid
5	20101240	10 Gallon Hopper Weldment
6	20101260	1-1/2" Hex Coupling
7	20101256	1-1/2" Aluminum Cam & Groove Socket
8	20101261	1-1/2" Cam Socket Gasket
9	20101257	1-1/2" Aluminum Cam & Groove Plug
10	20101255	1-1/2" x 1-1/4" 90° Elbow
11	20101243	10 Gallon Hopper Hanger Bracket

OPTIONAL ACCESSORIES

		SUCTION TUBE AND ACCESSORIES
Part Numbers	Description	
	20G197682	Suction Tube
	20G247301	1" I.D. x 6' Suction Hose with Couplings
	20G247302	1" I.D. x 10' Suction Hose with Couplings
	20G245136	55 Gallon Suction Tube Extension Kit <i>Includes Suction Tube and Couplings</i>
	20G181072	60 Mesh Strainer for 1" Suction Tube

		REPLACEMENT SCREEN FILTER ELEMENTS	
Part Numbers	Screen	U.O.M.	
	20G238436	30 Mesh	One Each
	20G224458	30 Mesh	Two Each
	20G238438	60 Mesh	One Each
	20G224459	60 Mesh	Two Each

		FILTER SUPPORTS		
Part Numbers	Type	Body Material	Maximum Working Pressure	
	Filter Support	Nylon	7,250 psi	

