

# SERVICE MANUAL

## DUSTMASTER® 50,000 CFM ELECTRIC DUST COLLECTORS

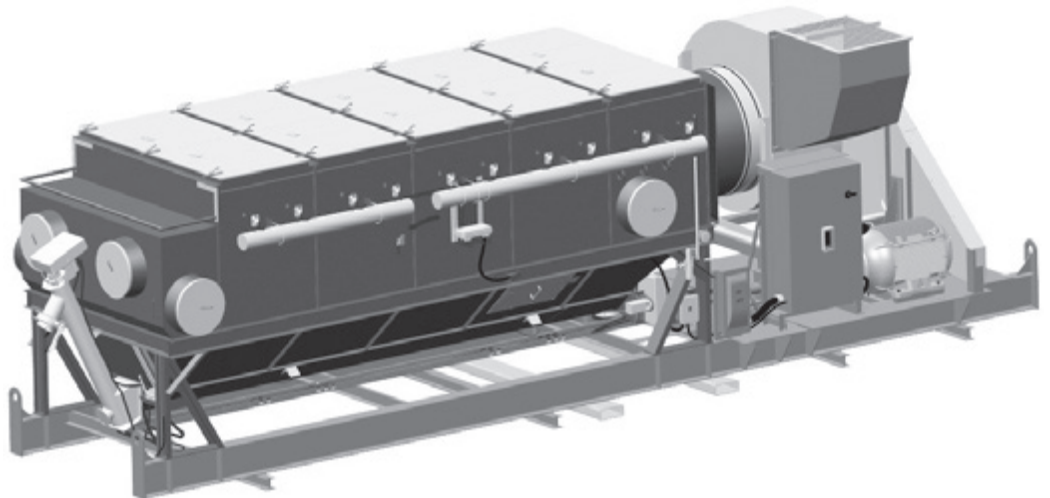
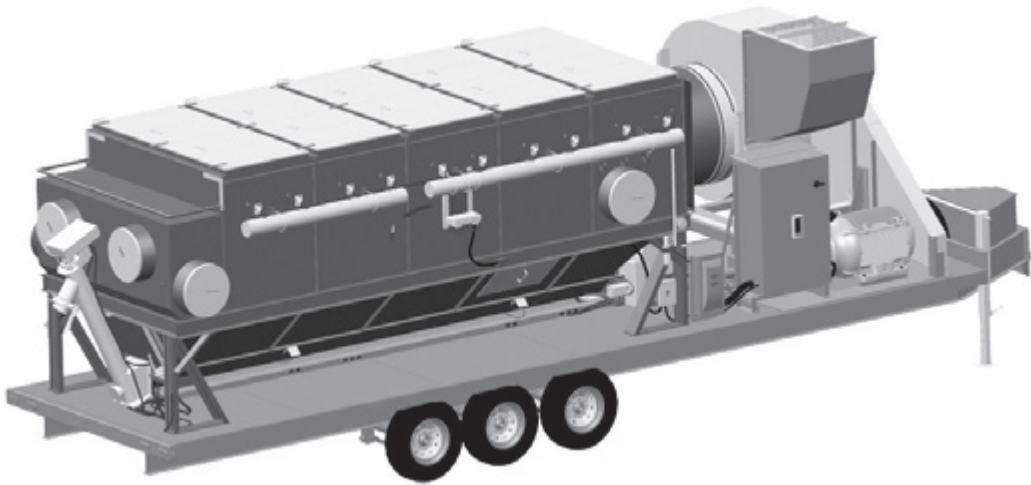

**BUILT MARCO  
TOUGH**  
MARCO MANUFACTURED

### **⚠ WARNING**

Before using this equipment, read, understand and follow all instructions in the Operator's Manuals provided with this equipment. If the user and/or assistants cannot read or understand the warnings and instructions, the employer of the user and/or assistants must provide adequate and necessary training to ensure proper operation and compliance with all safety procedures pertaining to this equipment. If Operator's Manuals have been lost, please visit [www.marco.us](http://www.marco.us), or contact Marco at 563.324.2519 for replacements. Failure to comply with the above warning could result in death or serious injury.

**Marco**®

## Company Profile

Since 1944, Marco has developed a strong tradition of providing innovative and reliable products and services to the surface preparation and protective coatings industries. We are the world's premier provider of Abrasives, Blasting, Coating, Dust Collectors, Engineered Systems, Rental, Safety, Service, Repair, & Modernization, and Vacuums.

Through innovative designs and a total commitment to quality, Marco manufactures products that increase production rates, create a safer workplace, and reduce maintenance costs. Marco's industry experience, manufacturing capabilities, legendary customer service, product availability, logistics services, and technology leadership is your assurance that we deliver high quality products and services, providing the best value to you, our customer.

## The Marco Difference

- **Industry Experience** – With Marco on your team, you have access to expertise which can only come from decades of industry leadership. We have organized our engineering department, production specialists, customer operations, and safety support into a “Center of Competence.” As a Marco customer, you have access to hundreds of years of cumulative experience related to your operations.
- **Manufacturing Excellence** – Marco is a U.S. based, ISO 9001:2008 certified manufacturer of equipment for the Surface Preparation and Protective Coatings industries. Marco's engineers benchmark the industry to ensure that we design and manufacture superior products that set the “Gold Standard” for performance, safety, and quality.
- **Legendary Customer Service** – Marco's legendary customer service team is staffed by friendly, highly-trained individuals who are focused on providing the highest level of product support, order accuracy, and customer satisfaction.
- **Product Availability** – We stock over 10,000 SKU's and have more than 45 shipping locations to serve North American and International markets for all major brands of blasting and coating equipment. As the largest provider of surface preparation and protective coatings equipment in the world, our inventory levels and product availability are unmatched.
- **Logistics Services** – Marco's in-house logistics team is dedicated to moving your shipment anywhere in the world. We move more than 14,000 truckloads every year, allowing you to save on freight costs by leveraging our buying power. Lower your process costs with a single invoice, which includes product and freight.
- **Technology Leadership** – Our website provides: Operator's Manuals, Part Numbers and Schematics Guides, SDS information, and Features & Specifications Guides, providing access to information 24/7. Our Extranet application allows you to receive quotes and place orders online. Our Intranet maintains a complete record of your purchase history to assist with ongoing support of your existing equipment and future purchasing decisions.

## Vision Statement

Marco is the world's premier provider of Abrasives, Blasting, Coating, Dust Collectors, Engineered Systems, Rental, Safety, Service, Repair, & Modernization, and Vacuums.

## Mission Statement

Marco provides strong leadership and innovation to the surface preparation and protective coatings industries. We dedicate our efforts to the continuous improvement of our products, services, processes, people, and most importantly, the quality of our customer's experience.

## Quality Statement

Marco is committed to providing superior quality in the design, manufacturing, distribution, rental, service, and repair of our products. Our ISO 9001:2008 certification extends throughout all operations in all locations. Continuous improvement of our processes and supply chain Integration comprise the core of our business strategy for delivering exceptional quality and value in all Marco products and services.

## Management Philosophy

We are a company dedicated to the success of every customer and associate. We discuss, debate, challenge, measure, and test our ideas. We will be boundless and limitless in our passion to improve. Through sound leadership and dedicated associates, we will ensure a long term, profitable future for Marco, our associates, customers, and suppliers.

# TABLE OF CONTENTS

<b>Company Profile</b> . . . . .	<b>1</b>	Remove & Install Main Auger Hydraulic Motor . . . . .	<b>21</b>
<b>Definition of Terms</b> . . . . .	<b>2</b>	Remove & Install Fan Drive Belt Assembly . . . . .	<b>23</b>
<b>Hazard Identifications</b> . . . . .	<b>3</b>	Remove & Install Discharge Auger Assembly . . . . .	<b>25</b>
<b>Description</b> . . . . .	<b>6</b>	Remove & Install Main Auger . . . . .	<b>27</b>
Description . . . . .	<b>6</b>	Remove & Install Discharge Auger . . . . .	<b>31</b>
<b>Maintenance</b> . . . . .	<b>7</b>	Remove & Install Fan . . . . .	<b>35</b>
Remove & Install Fan Drive Belt . . . . .	<b>7</b>	Remove & Install Pulser Solenoid . . . . .	<b>36</b>
Adjust Tension of Fan Drive Belt . . . . .	<b>8</b>	Remove & Install Pulser Manifold . . . . .	<b>37</b>
Adjust Main Auger Drive Chain . . . . .	<b>9</b>	Remove & Install Timer Board . . . . .	<b>39</b>
Adjust Discharge Auger Drive Chain . . . . .	<b>10</b>	Remove & Install Dust Collector Filter Cartridge Hatch Assembly . . . . .	<b>40</b>
Adjust Pulse Separation . . . . .	<b>11</b>	Remove & Install Main Auger Protective Grate . . . . .	<b>41</b>
Remove & Install Dust Collector Filter Cartridges . . . . .	<b>12</b>	Remove & Install Magnehelic Gauge . . . . .	<b>42</b>
Hydraulic System Schematic . . . . .	<b>13</b>	Remove & Install Pneumatic Ball Vibrators . . . . .	<b>43</b>
Remove & Install Hydraulic Oil Filter . . . . .	<b>14</b>	Disassemble & Assemble Diaphragm Valve . . . . .	<b>43</b>
Remove & Install Hydraulic Oil Tank . . . . .	<b>15</b>	<b>Troubleshooting</b> . . . . .	<b>44</b>
Remove & Install Hydraulic Oil Filter Assembly . . . . .	<b>16</b>	<b>Limited Warranty</b> . . . . .	<b>46</b>
Remove & Install Hydraulic Oil Pump . . . . .	<b>17</b>	Disclaimer of Warranty . . . . .	<b>46</b>
Remove & Install Hydraulic Control Valve . . . . .	<b>18</b>	Exclusive Remedy for Warranty Claims . . . . .	<b>46</b>
Remove & Install Discharge Auger Hydraulic Motor . . . . .	<b>19</b>	Limitation of Remedies . . . . .	<b>46</b>

## DEFINITION OF TERMS

### **DANGER**

This is an example of danger. This indicates an imminently hazardous situation which, if not avoided, will result in death or serious injury.

### **CAUTION**

This is an example of a caution. This indicates a potentially hazardous situation which, if not avoided, may result in minor or moderate injury. It can also be used to alert against unsafe practices.

### **WARNING**

This is an example of a warning. This indicates a potentially hazardous situation which, if not avoided, could result in death or serious injury.

### **NOTICE**

This is an example of a notice. This indicates policy or practice directly related to safety of personnel or protection of property.

## HAZARD IDENTIFICATIONS

### WARNING

#### **Failure to comply with ANY WARNING listed below could result in death or serious injury.**

- ▶ OSHA sets exposure limits to protect workers from exposure to respirable crystalline silica, 29 CFR 1910.1053. Airborne dust could increase the exposure levels beyond permissible limits. Breathing dust containing silica could cause silicosis, a fatal lung disease. Breathing dust during abrasive blasting operations, post-blast cleaning operations, and/or servicing equipment within the abrasive blasting area may expose an individual to conditions that could cause asbestosis, lead poisoning and/or other serious or fatal diseases. Harmful dust containing toxic material from abrasives or surfaces being abrasive blasted can remain suspended in the air for long periods of time after abrasive blasting has ceased. A NIOSH-approved, well-maintained, respirator designed for the specific operation being performed must be used by anyone abrasive blasting, handling or using the abrasive, and anyone in the area of the dust.
- ▶ Contact NIOSH and OSHA offices to determine the proper respirator for your specific application. The air supplied to the respirator must be at least Grade D quality as described in Compressed Gas Association Commodity Specification G-7.1 and as specified by OSHA Regulation 1910.134. Ensure air filter and respirator system hoses are not connected to non-air sources or in-plant lines that may contain nitrogen, oxygen, acetylene or other non-breathable gases. Before removing respirator, use an air monitoring instrument to determine if the atmosphere is safe to breathe.
- ▶ You must comply with all OSHA, local, City, State, Province, Country and jurisdiction regulations, ordinances and standards, related to your particular work area and environment. Keep unprotected individuals out of the work area.
- ▶ Abrasive blasting operators must receive thorough training on the use of abrasive resistant attire which includes: supplied-air respirator, abrasive blasting suit, safety shoes, gloves, ear protection and eye protection. Protect the operator and bystanders by complying with NIOSH and OSHA Safety Standards.
- ▶ Inspect all equipment for wear or damage before and after each use. Failure to use Original Equipment Manufacturer repair parts and failure to immediately replace worn or damaged components could void warranties and cause malfunctions.
- ▶ OSHA requires abrasive blasting nozzles be equipped with an operating valve, which shall be designed to be held open only by continuous hand pressure and shall close immediately upon release of hand pressure (i.e., a “deadman” control). The valve shall not be modified in any manner that would allow it to remain open without the application of continuous hand pressure by the operator. Failure to comply with the above warning could result in release of high speed abrasive and compressed air resulting in death or serious injury. OSHA 29CFR 1910.244(b)
- ▶ Point the abrasive blasting nozzle only at the surface being abrasive blasted. Never point the abrasive blasting nozzle or abrasive stream at yourself or others.
- ▶ Unless otherwise specified, maximum working pressure of abrasive blasting pots and related components must not exceed 150 psi. Exceeding maximum working pressure of 150 psi could cause the abrasive blasting pot and components to burst. Failure to comply with the above warning could result in death or serious injury.
- ▶ Never weld, grind or drill on the abrasive blasting pot (or any pressure vessel). Doing so will void ASME certification and manufacturer’s warranty. Welding, grinding or drilling on the abrasive blasting pot (or any pressure vessel) could weaken the vessel causing it to burst. Failure to comply with the above warning could result in death or serious injury. (ASME Pressure Vessel Code, Section VIII, Division 1)
- ▶ This equipment is not intended for use in any area that might be considered a hazardous location, as described in the National Electric Code NFPA 70, Article 500. Use of this equipment in a hazardous location could cause an explosion or electrocution.
- ▶ Never attempt to move an abrasive blasting pot containing abrasive. Never attempt to manually move abrasive blasting pots greater than 6.5 cubic foot capacity. Always use at least two capable people to manually move an abrasive blasting pot on flat, smooth surfaces. A mechanical lifting device must be used if an abrasive blasting pot is moved in any other manner.

# HAZARD IDENTIFICATIONS

## **WARNING**

**Failure to comply with ANY WARNING listed below could result in death or serious injury.**

- ▶ This product is not for use in wet environments. Always use a Ground Fault Interrupter Circuit (GFI) for all electrical power source connections. Use of this product in wet environments could create a shock or electrocution hazard.
- ▶ Frozen moisture could cause restrictions and obstructions in pneumatic control lines. Any restriction or obstruction in the pneumatic control lines could prevent the proper activation and deactivation of the remote control system, resulting in the release of high speed abrasive and compressed air. In conditions where moisture may freeze in the control lines an antifreeze injection system approved for this application can be installed.
- ▶ Do not cut, obstruct, restrict or pinch pneumatic control lines. Doing so could prevent the proper activation and deactivation of the remote control system, resulting in the release of high speed abrasive and compressed air.
- ▶ Use of Marco remote control switches with other manufacturer's remote control systems could cause unintended activation of remote control systems resulting in the release of high speed abrasive and compressed air. Only Marco remote control switches should be used with Marco remote control systems.
- ▶ Always be certain to have secure footing when abrasive blasting. There is a recoil hazard when abrasive blasting starts that may cause user to fall and misdirect the abrasive stream at operator or bystander.
- ▶ Never use an abrasive blasting pot or attachments as a climbing device. The person could slip and fall. The abrasive blasting pot could become unstable and tip over.
- ▶ For equipment manufactured by entities other than Marco, you must consult the Original Equipment Manufacturer operator's manuals, information, training, instructions and warnings, for the proper and intended use of all equipment.
- ▶ Flammable fumes, such as solvent and paint fumes in the work area can present an ignition or explosion hazard if allowed to collect in adequate concentrations. To reduce conditions that could result in a fire or an explosion, provide adequate ventilation, eliminate all ignition or spark sources, keep the work area free of debris, store solvents and solvent contaminated rags in approved containers, follow proper grounding procedures, do not plug/unplug power cord or turn on/off power switches when flammable fumes are present, keep a working fire extinguisher or provide another fire suppression system in the work area. Cease all operations and correct condition if a spark or ignition source is identified during operation.
- ▶ Always depressurize the entire system, disconnect all power sources and lockout/tagout all components before any maintenance or troubleshooting is attempted. Failure to comply with the above warning could cause electrical shock and inadvertent activation of equipment resulting in death or serious injury.
- ▶ Moving parts can present an area where crushing, pinching, entanglement or amputation may occur. Do not place body parts or foreign objects in any area where there are moving parts.
- ▶ Surfaces of heated supply tanks, drums and/or lines as well as the adjoining plumbing may become hot during normal use. Do not touch these heated surfaces without proper protection. Deactivate and allow sufficient time for all surfaces to cool before attempting any maintenance.
- ▶ High-pressure fluid from gun, hose leaks, or ruptured components can pierce skin and can cause a serious injury that may result in amputation. Do not point gun or spray tip at anyone or at any part of the body. Keep clear of any leaks or ruptures. Depressurize the entire system before attempting cleaning, inspecting, or servicing equipment.
- ▶ Exposure to toxic fluids or fumes may occur during the normal operation of this system. Before attempting to fill, use, or service this system, read SDS's to know the specific hazards of the fluids you are using. Always use proper Personal Protective Equipment when attempting to fill, use, or service this system.
- ▶ The use of this product for any purpose other than originally intended or altered from its original design is prohibited.
- ▶ Never hang objects from the abrasive blasting pot handle. Doing so may cause the abrasive blasting pot to become unstable and tip over.



## HAZARD IDENTIFICATIONS

### **⚠ CAUTION**

**Failure to comply with ANY CAUTION listed below may result in minor or moderate injury.**

- ▶ Static electricity can be generated by abrasive moving through the abrasive blasting hose causing a shock hazard. Prior to use, ground the abrasive blasting pot and abrasive blasting nozzle to dissipate static electricity.
- ▶ High decibel noise levels are generated during the abrasive blasting process which may cause loss of hearing. Ensure appropriate Personal Protective Equipment and hearing protection is in use.

### **NOTICE**

**Failure to comply with ANY NOTICE listed below could pose a hazard to personnel or property.**

- ▶ See Air & Abrasive Consumption Chart for estimated abrasive consumption rates and required air flow (cubic feet per minute). Your system must meet these minimum requirements to ensure proper function and performance.
- ▶ Always use abrasive that is dry and properly screened. This will reduce the potential for obstructions to enter the remote control system, abrasive metering valve and abrasive blasting nozzle.
- ▶ Moisture build-up occurs when air is compressed. Any moisture within the abrasive blasting system will cause abrasive to clump, clogging metering valves, hoses and nozzles. Install an appropriately sized moisture separator at the inlet of the abrasive blasting system. Leave the moisture separator petcock slightly open to allow for constant release of water. If insufficient volume of air exists and petcock is unable to be left open (at all times) petcock should be opened frequently to release water.
- ▶ To reduce abrasive intrusion in the air supply hose, depressurize the abrasive blasting pot before shutting off air supply from compressor.
- ▶ Inspect abrasive blasting nozzle before placing into service. Damage to abrasive blasting nozzle liner or jacket may occur during shipping. If you receive a damaged abrasive blasting nozzle, contact your distributor immediately for replacement. Abrasive blasting nozzles placed into service may not be returned. Abrasive blasting nozzle liners are made of fragile materials and can be damaged by rough handling and striking against hard surfaces. Never use a damaged abrasive blasting nozzle.
- ▶ Abrasive blasting at optimal pressure for the abrasive used is critical to productivity. Example: For an abrasive with an optimal abrasive blasting pressure of 100 psi at the abrasive blasting nozzle, one pound per square inch of pressure loss will reduce abrasive blasting efficiency by 1.5%. A 10 psi reduction in air pressure will cause a 15% loss of efficiency. Use a Needle Pressure Gauge to identify pressure drops in your system. Consult with your abrasive supplier for the requirements of your abrasive.
- ▶ Replace abrasive blasting nozzle if liner or jacket is cracked or damaged. Replace abrasive blasting nozzle if original orifice size has worn 1/16" or more. Determine abrasive blasting nozzle wear by inserting a drill bit 1/16" larger than original size of abrasive blasting nozzle orifice. If the drill bit passes through abrasive blasting nozzle, replacement is needed.

# DESCRIPTION

## Description

A dust collector creates an engineered air flow in an enclosure, providing ventilation and collecting airborne dust and debris. Abrasive blasting performed in an enclosure requires a dust management system for compliance with OSHA regulations governing the work site. Removing airborne dust and debris from an enclosure improves work site safety and visibility, increasing production rates. The Dustmaster® 50,000 CFM Electric Dust Collectors have a reverse incline blade fan matched to a 150 horsepower Electric motor to generate up to 50,000 CFM of air flow. Typical applications include blast rooms, blast yards, bridges, oil refineries, offshore platforms, pipelines, shipyards, storage tanks, and water treatment plants.

# MAINTENANCE

## Remove & Install Fan Drive Belt

### **⚠ WARNING**

W-562

Always depressurize the entire system, disconnect all power sources and lockout/tagout all components before any maintenance or troubleshooting is attempted. Failure to comply with the above warning could cause electrical shock and inadvertent activation of equipment resulting in death or serious injury.

### **⚠ WARNING**

W-586

Moving parts can present an area where crushing, pinching, entanglement or amputation may occur. Do not place body parts or foreign objects in any area where there are moving parts. Failure to comply with the above warning could result in death or serious injury.

### **⚠ WARNING**

W-590

When performing service or maintenance on systems or devices requiring access from an elevated position, you must comply with all OSHA, local, City, State, Province, Country and jurisdiction regulations, ordinances and standards, as related to working in elevated work areas. Failure to comply with the above warning could result in death or serious injury.

- 1) Turn off main power disconnect on main control box.
- 2) Remove eight Bolts and Washers (1).
- 3) Remove Upper Belt Cover (2).
- 4) Remove Lower Belt Cover (3).

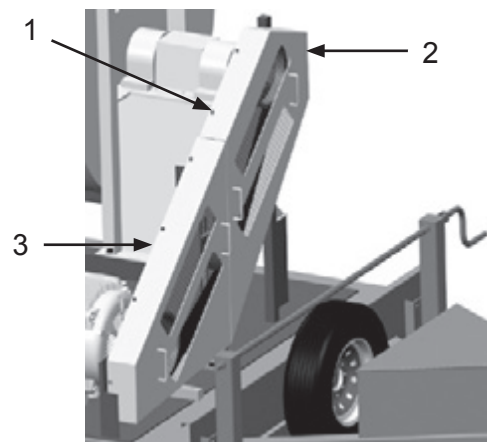

- 5) Loosen two Bolts (5) and turn Nut (6) until Belt (4) is loose and can be removed.
- 6) Remove Belt (4) and replace.
- 7) Adjust fan drive belt tension. (See Adjust Tension of Fan Drive Belt.)
- 8) Install parts in reverse order.

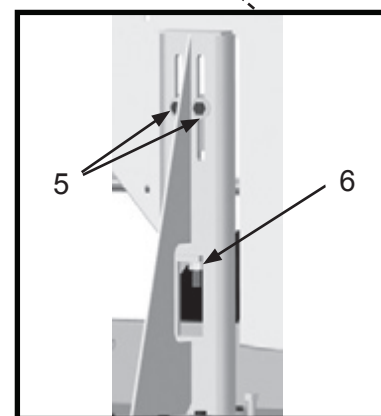
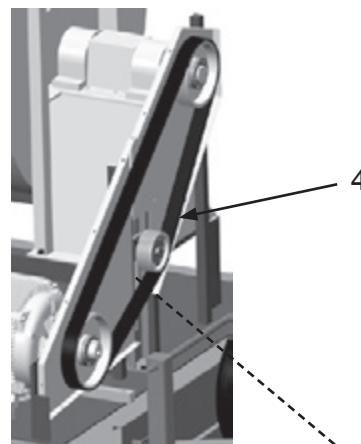



# MAINTENANCE

## Adjust Tension of Fan Drive Belt

### **⚠ WARNING**

W-562

Always depressurize the entire system, disconnect all power sources and lockout/tagout all components before any maintenance or troubleshooting is attempted. Failure to comply with the above warning could cause electrical shock and inadvertent activation of equipment resulting in death or serious injury.

### **⚠ WARNING**

W-586

Moving parts can present an area where crushing, pinching, entanglement or amputation may occur. Do not place body parts or foreign objects in any area where there are moving parts. Failure to comply with the above warning could result in death or serious injury.

### **⚠ WARNING**

W-590

When performing service or maintenance on systems or devices requiring access from an elevated position, you must comply with all OSHA, local, City, State, Province, Country and jurisdiction regulations, ordinances and standards, as related to working in elevated work areas. Failure to comply with the above warning could result in death or serious injury.

- 1) Turn off main power disconnect on main control box.
- 2) Remove eight Bolts and Washers (1).
- 3) Remove Upper Belt Cover (2).
- 4) Remove Lower Belt Cover (3).

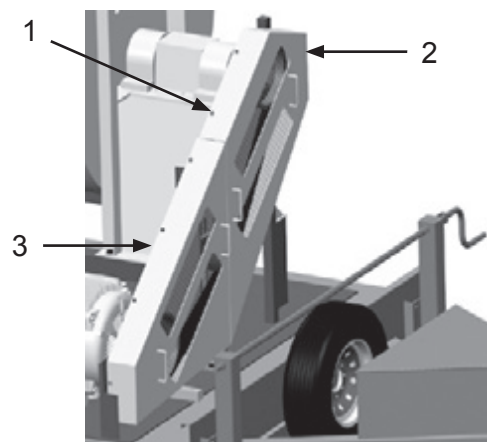

- 5) Inspect Belt (4) for wear, abrasion, and damage. Replace as needed.
- 6) Check tension of Belt (4) by pushing downward on Belt and measure Distance (A) of travel. Belt should have a deflection distance of approximately 1 inch; applied force of approximately 70 pounds.
- 7) To adjust tension of Belt, loosen two Bolts (5) and turn Nut (6) until deflection distance is approximately 1 inch; applied force of approximately 70 pounds. If distance cannot be attained, replace belt.
- 8) Tighten two Bolts (5).
- 9) Install parts in reverse order.

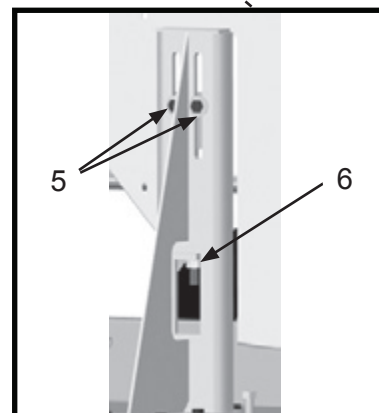
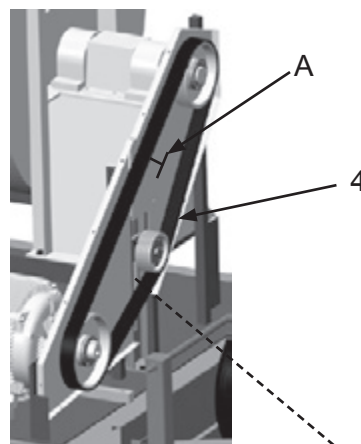

# MAINTENANCE

## Adjust Main Auger Drive Chain

### **WARNING**

W-562

Always depressurize the entire system, disconnect all power sources and lockout/tagout all components before any maintenance or troubleshooting is attempted. Failure to comply with the above warning could cause electrical shock and inadvertent activation of equipment resulting in death or serious injury.

- 1) Close Ball Valves (1).
- 2) Loosen four Bolts (2).

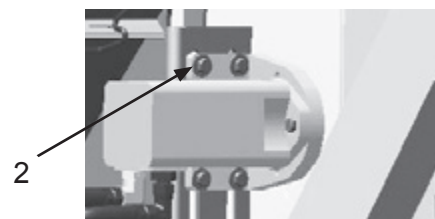
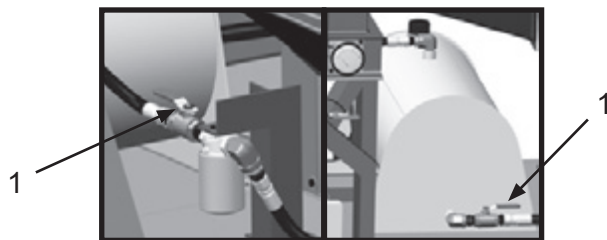

### **WARNING**

W-586

Moving parts can present an area where crushing, pinching, entanglement or amputation may occur. Do not place body parts or foreign objects in any area where there are moving parts. Failure to comply with the above warning could result in death or serious injury.

- 3) Remove four Bolts and Washers (4) and remove Cover (3).

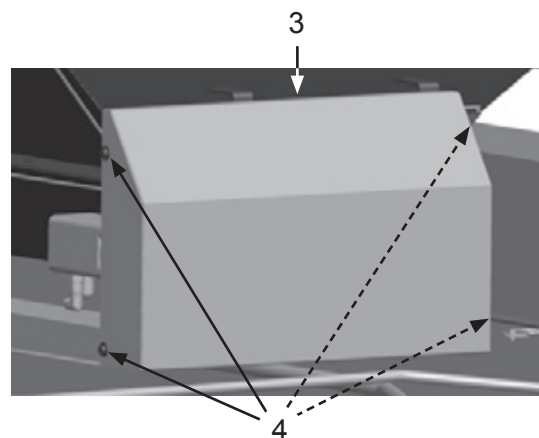

- 4) Move Hydraulic Motor (6) to set Chain (7) deflection to approximately 5/8 - 7/8 inch. Tighten four Bolts (5).

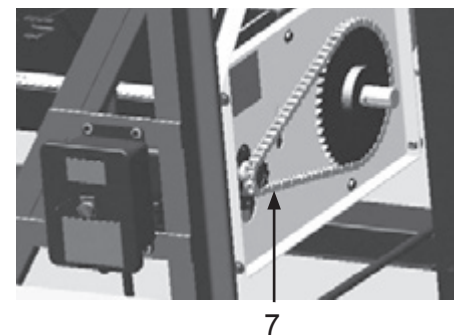
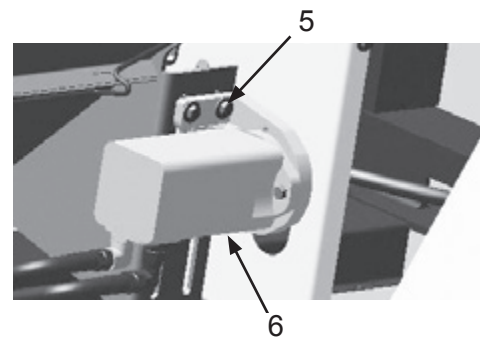

# MAINTENANCE

## Adjust Discharge Auger Drive Chain

### **WARNING**

W-562

Always depressurize the entire system, disconnect all power sources and lockout/tagout all components before any maintenance or troubleshooting is attempted. Failure to comply with the above warning could cause electrical shock and inadvertent activation of equipment resulting in death or serious injury.

### **WARNING**

W-587

Escaping fluid under pressure can penetrate skin and tissue causing injury. Stop pump and relieve pressure before attempting maintenance or repair. Ensure all fittings are properly tightened before restoring pressure. If injury should occur, immediately seek medical attention. Failure to comply with the above warning could result in death or serious injury.

### **WARNING**

W-586

Moving parts can present an area where crushing, pinching, entanglement or amputation may occur. Do not place body parts or foreign objects in any area where there are moving parts. Failure to comply with the above warning could result in death or serious injury.

### **WARNING**

W-590

When performing service or maintenance on systems or devices requiring access from an elevated position, you must comply with all OSHA, local, City, State, Province, Country and jurisdiction regulations, ordinances and standards, as related to working in elevated work areas. Failure to comply with the above warning could result in death or serious injury.

- 1) Turn off main power disconnect on main control box.
- 2) Close Ball Valve (1).
- 3) Remove three Bolts, and Washers (2) and Cover (3).

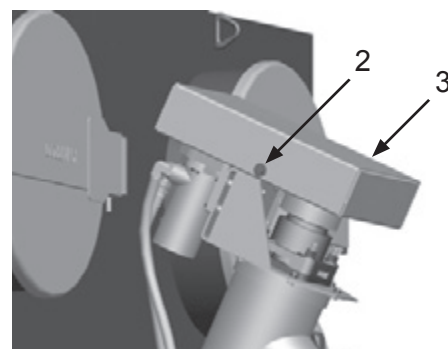
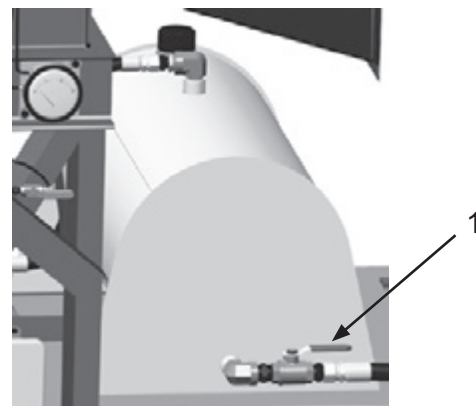

- 4) Loosen four Bolts (4) from Sliding Motor Mount (5).

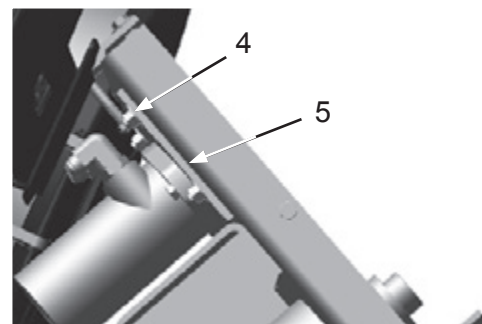

- 5) Remove Chain (6). Inspect for wear or damage. Replace as needed.

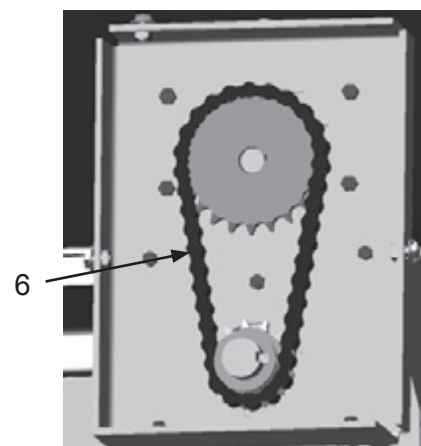

# MAINTENANCE

## Adjust Pulse Separation

### **WARNING**

Always depressurize the entire system, disconnect all power sources and lockout/tagout all components before any maintenance or troubleshooting is attempted. Failure to comply with the above warning could cause electrical shock and inadvertent activation of equipment resulting in death or serious injury.

- 1) Open enclosure door of Timer Controller.
- 2) Locate Adjustment Knobs (1 and 2).

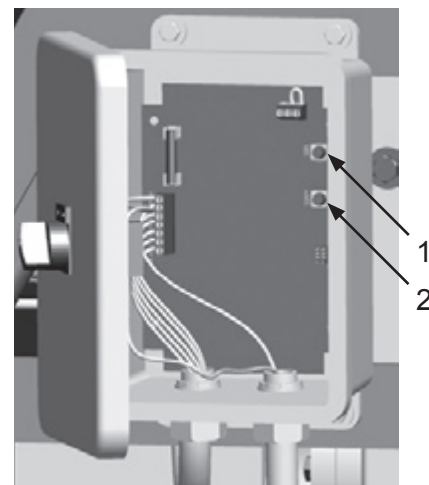

- 3) Set the Pulse Separation, the elapsed time between pulses, by moving Knob (3). The recommended elapsed time between pulses is the minimum time needed for pulse header to return to full pressure. Depending on conditions, the elapsed time may need to be changed. Elapsed time between pulses should be between 5–15 seconds.

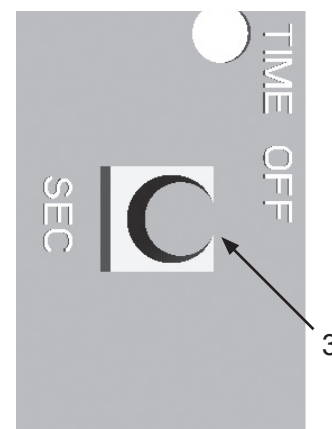

- 4) Set Pulse Duration, the elapsed time of compressed air entering the filters, by moving Knob (4). The recommended elapsed time of compressed air entering the filters is 200 milliseconds (mSEC). Depending on conditions, the elapsed time of air entering the filters should be between 200–350 milliseconds.
- 5) Close enclosure door of Timer Controller.

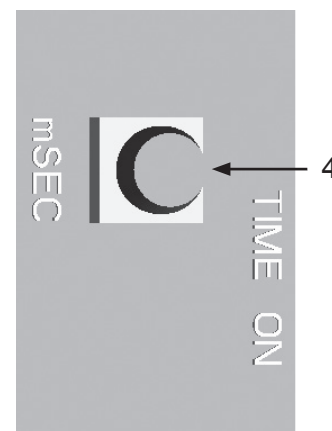

# MAINTENANCE

## Remove & Install Dust Collector Filter Cartridges

### **⚠ WARNING**

W-562

Always depressurize the entire system, disconnect all power sources and lockout/tagout all components before any maintenance or troubleshooting is attempted. Failure to comply with the above warning could cause electrical shock and inadvertent activation of equipment resulting in death or serious injury.

### **⚠ WARNING**

W-501

Breathing dust containing silica could cause silicosis, a fatal lung disease. Breathing dust during abrasive blasting operations, post-blast cleaning operations, and/or servicing equipment within the abrasive blasting area may expose an individual to conditions that could cause asbestosis, lead poisoning and/or other serious or fatal diseases. Harmful dust containing toxic material from abrasives or surfaces being abrasive blasted can remain suspended in the air for long periods of time after abrasive blasting has ceased. A NIOSH-approved, well-maintained, respirator designed for the specific operation being performed must be used by anyone abrasive blasting, handling or using the abrasive, and anyone in the area of the dust. Failure to comply with the above warning could result in death or serious injury.

- 1) Remove Compression Coupling (2) from Pulser System Blowpipe (1).
- 2) Remove Pulser System Blowpipe (1).

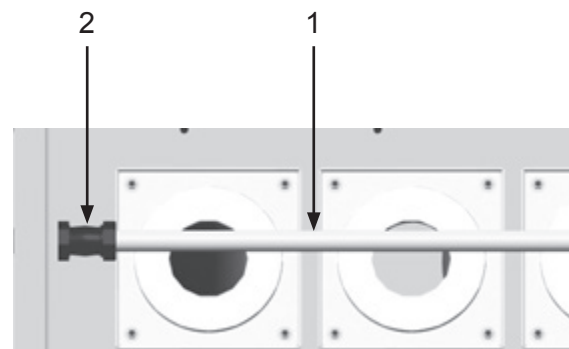

- 3) Remove four Washers and Nuts (3) and remove Filter Retainer (4). Repeat for remaining Filter Retainers.
- 4) Remove Filter Cartridge (5). Repeat for remaining Filter Cartridges.
- 5) Install parts in reverse order.

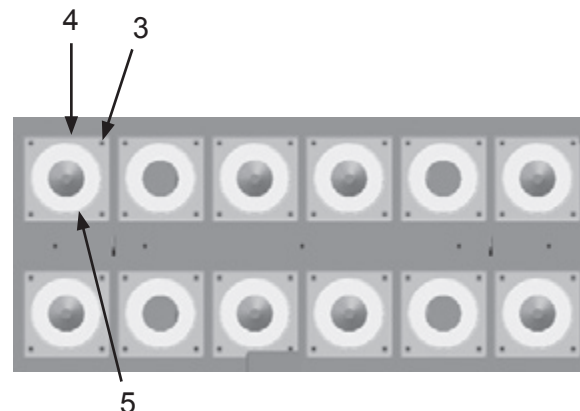

# MAINTENANCE

## Hydraulic System Schematic

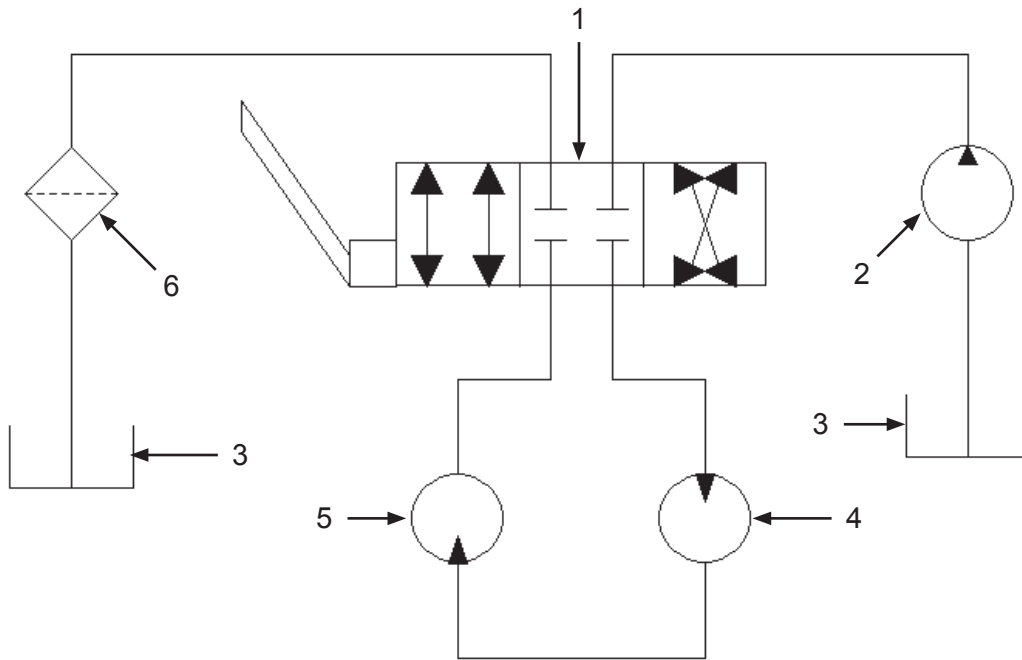

- 1) Hydraulic Control Valve
- 2) Hydraulic Pump
- 3) Hydraulic Oil Tank
- 4) Main Auger Motor
- 5) Discharge Auger Motor
- 6) Hydraulic Oil Filter



# MAINTENANCE

## Remove & Install Hydraulic Oil Filter

### **⚠ WARNING**

W-562

Always depressurize the entire system, disconnect all power sources and lockout/tagout all components before any maintenance or troubleshooting is attempted. Failure to comply with the above warning could cause electrical shock and inadvertent activation of equipment resulting in death or serious injury.

### **⚠ WARNING**

W-587

Escaping fluid under pressure can penetrate skin and tissue causing injury. Stop pump and relieve pressure before attempting maintenance or repair. Ensure all fittings are properly tightened before restoring pressure. If injury should occur, immediately seek medical attention. Failure to comply with the above warning could result in death or serious injury.

### **⚠ WARNING**

W-589

Exposure to diesel fuel, lubricant grease and oil, hydraulic oil, or engine coolant can cause personal injury. Do not allow these products to remain in contact with the skin or eyes. Ingestion of these products or inhalation of fumes from these products can cause dizziness, nausea, vomiting, or poisoning. If exposure to any of these products occurs, or if any of these products are ingested or if fumes are inhaled, please consult the product's SDS for proper first aid or medical procedures. Failure to comply with the above warning could result in death or serious injury.

- 1) Close Ball Valve (1).
- 2) Remove and replace Filter Element (2).
- 3) Open Ball Valve (1).

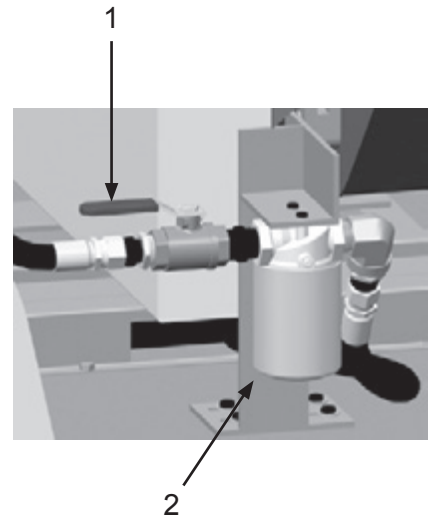

# MAINTENANCE

## Remove & Install Hydraulic Oil Tank

### **WARNING**

Always depressurize the entire system, disconnect all power sources and lockout/tagout all components before any maintenance or troubleshooting is attempted. Failure to comply with the above warning could cause electrical shock and inadvertent activation of equipment resulting in death or serious injury.

### **WARNING**

Escaping fluid under pressure can penetrate skin and tissue causing injury. Stop pump and relieve pressure before attempting maintenance or repair. Ensure all fittings are properly tightened before restoring pressure. If injury should occur, immediately seek medical attention. Failure to comply with the above warning could result in death or serious injury.

### **WARNING**

Exposure to diesel fuel, lubricant grease and oil, hydraulic oil, or engine coolant can cause personal injury. Do not allow these products to remain in contact with the skin or eyes. Ingestion of these products or inhalation of fumes from these products can cause dizziness, nausea, vomiting, or poisoning. If exposure to any of these products occurs, or if any of these products are ingested or if fumes are inhaled, please consult the product's SDS for proper first aid or medical procedures. Failure to comply with the above warning could result in death or serious injury.

- 1) Close Ball Valves (8 and 11).
- 2) Remove Filler Cap (1).

*Note: Drain hoses into container suitable for collecting fluids. Comply with all OSHA, local, City, State, Province, Country and jurisdiction regulations, ordinances and standards, related to your particular work area and environment.*

*Note: Hydraulic Oil Tank capacity is approximately 40 gal.*

- 3) Remove Pipe Plug (15). Connect a hose to outlet to aid recovery of hydraulic fluid.
- 4) Open Ball Valve (14) and allow hydraulic oil to empty from tank.
- 5) Disconnect Hoses (5 and 6).
- 6) Remove Ball Valve (14), Nipple (13) and Adapter (12).
- 7) Remove Elbow (2), Bushing (3), and Adapter (4).
- 8) Remove Ball Valve (8), Elbow (10) and Adapters (7 and 9).

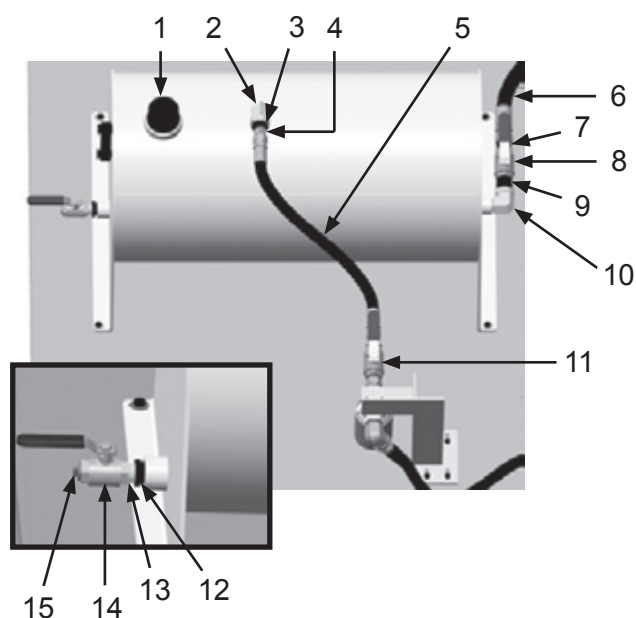

*Note: Approximate empty weight of Hydraulic Oil Tank is 181 lbs. Use suitable lifting devices to support or maneuver Hydraulic Oil Tank.*

- 9) Attach a suitable lifting device to Hydraulic Oil Tank (16).
- 10) Remove four Bolts, Washers, and Nuts (17).
- 11) Remove Hydraulic Oil Tank (16).
- 12) Install parts in reverse order using the following special instructions:
  - Fill Hydraulic Oil Tank using appropriate hydraulic oil. (See Pre-Startup).
  - Activate Auger System and check for leaks. Repair as needed.

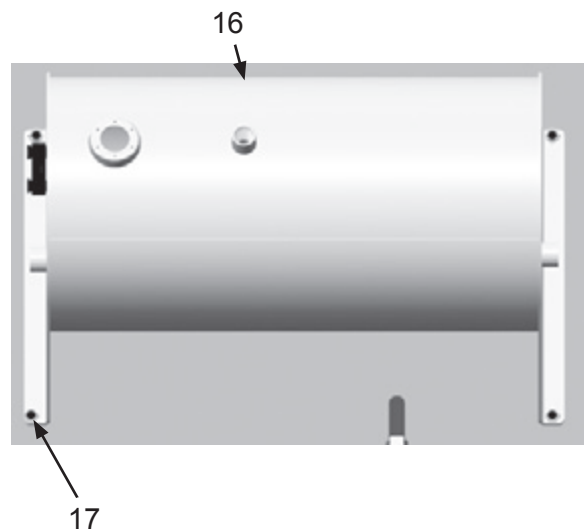

# MAINTENANCE

## Remove & Install Hydraulic Oil Filter Assembly

### **WARNING**

W-562  
Always depressurize the entire system, disconnect all power sources and lockout/tagout all components before any maintenance or troubleshooting is attempted. Failure to comply with the above warning could cause electrical shock and inadvertent activation of equipment resulting in death or serious injury.

### **WARNING**

W-587  
Escaping fluid under pressure can penetrate skin and tissue causing injury. Stop pump and relieve pressure before attempting maintenance or repair. Ensure all fittings are properly tightened before restoring pressure. If injury should occur, immediately seek medical attention. Failure to comply with the above warning could result in death or serious injury.

### **WARNING**

W-589  
Exposure to diesel fuel, lubricant grease and oil, hydraulic oil, or engine coolant can cause personal injury. Do not allow these products to remain in contact with the skin or eyes. Ingestion of these products or inhalation of fumes from these products can cause dizziness, nausea, vomiting, or poisoning. If exposure to any of these products occurs, or if any of these products are ingested or if fumes are inhaled, please consult the product's SDS for proper first aid or medical procedures. Failure to comply with the above warning could result in death or serious injury.

- 1) Close two Ball Valves (1).

*Note: Drain hoses into container suitable for collecting fluids. Comply with all OSHA, local, City, State, Province, Country and jurisdiction regulations, ordinances and standards, related to your particular work area and environment.*

*Note: Label all hoses and connections to aid installation.*

- 2) Disconnect Hoses (2 and 9).
- 3) Remove Filter Element (10).
- 4) Remove Adapter (3).
- 5) Remove Reducer Fitting (4).
- 6) Remove Ball Valve (11).
- 7) Remove Nipple (5).
- 8) Remove Elbow (6).
- 9) Remove Reducer Fitting (7).
- 10) Remove Adapter (8).

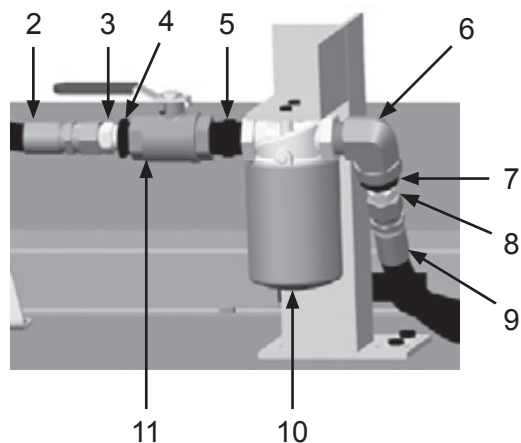
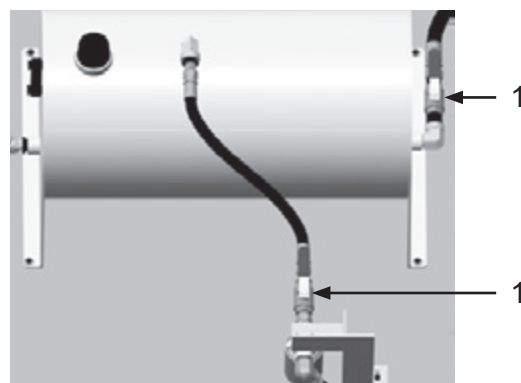

- 11) Remove two Bolts and Washers (12), and Filter Head (13).
- 12) Install parts in reverse order.
- 13) Check hydraulic oil level (See Pre-Startup).
- 14) Activate Auger System and check for hydraulic oil leaks.

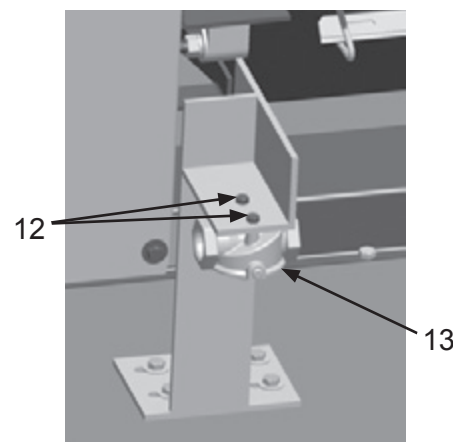

# MAINTENANCE

## Remove & Install Hydraulic Oil Pump

### **WARNING**

W-562

Always depressurize the entire system, disconnect all power sources and lockout/tagout all components before any maintenance or troubleshooting is attempted. Failure to comply with the above warning could cause electrical shock and inadvertent activation of equipment resulting in death or serious injury.

### **WARNING**

W-587

Escaping fluid under pressure can penetrate skin and tissue causing injury. Stop pump and relieve pressure before attempting maintenance or repair. Ensure all fittings are properly tightened before restoring pressure. If injury should occur, immediately seek medical attention. Failure to comply with the above warning could result in death or serious injury.

### **WARNING**

W-589

Exposure to diesel fuel, lubricant grease and oil, hydraulic oil, or engine coolant can cause personal injury. Do not allow these products to remain in contact with the skin or eyes. Ingestion of these products or inhalation of fumes from these products can cause dizziness, nausea, vomiting, or poisoning. If exposure to any of these products occurs, or if any of these products are ingested or if fumes are inhaled, please consult the product's SDS for proper first aid or medical procedures. Failure to comply with the above warning could result in death or serious injury.

- 1) Turn off main power disconnect on main control box.
- 2) Close Ball Valve (1).

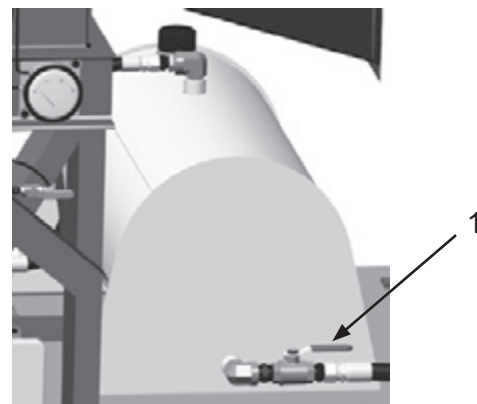

*Note: Drain hoses into container suitable for collecting fluids. Comply with all OSHA, local, City, State, Province, Country and jurisdiction regulations, ordinances and standards, related to your particular work area and environment.*

*Note: Label all hoses and connections to aid installation.*

- 3) Disconnect Hydraulic Hoses (2 and 5).
- 4) Note orientation and location of two Fittings (6) and remove Fittings.
- 5) Remove four Bolts and Washers (4) and Cover (3).
- 6) Remove four Bolts, Nuts and eight Washers (8) and remove Motor (7) with Cover (9).
- 7) Remove Components (10,11,12) from shafts.
- 8) Remove two Bolts and Washers (13) and Cover (9).
- 9) Install parts in reverse order.
- 10) Check hydraulic oil level. (See Pre-Startup).
- 11) Activate Auger System and check for hydraulic oil leaks. Repair as needed.

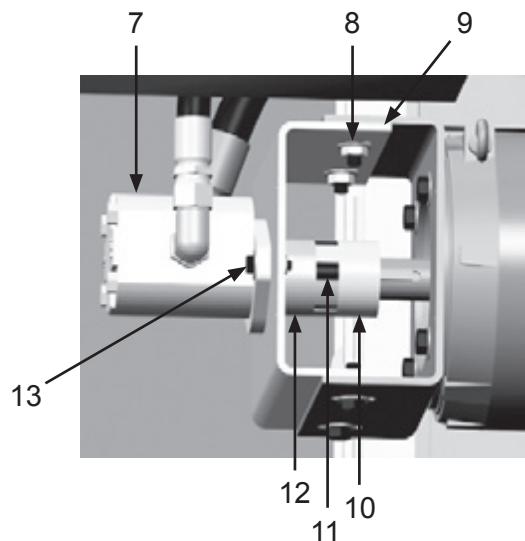
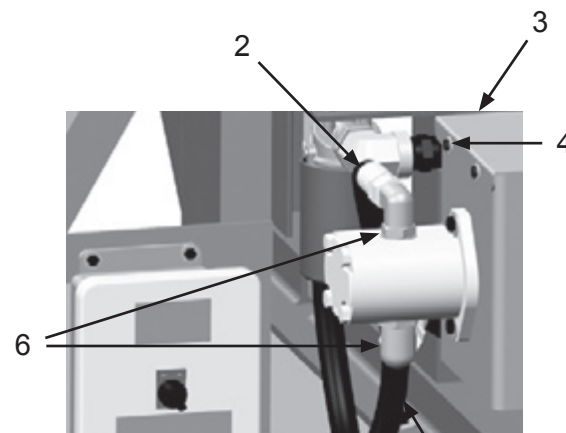

# MAINTENANCE

## Remove & Install Hydraulic Control Valve

### **WARNING**

W-562

Always depressurize the entire system, disconnect all power sources and lockout/tagout all components before any maintenance or troubleshooting is attempted. Failure to comply with the above warning could cause electrical shock and inadvertent activation of equipment resulting in death or serious injury.

### **WARNING**

W-587

Escaping fluid under pressure can penetrate skin and tissue causing injury. Stop pump and relieve pressure before attempting maintenance or repair. Ensure all fittings are properly tightened before restoring pressure. If injury should occur, immediately seek medical attention. Failure to comply with the above warning could result in death or serious injury.

### **WARNING**

W-589

Exposure to diesel fuel, lubricant grease and oil, hydraulic oil, or engine coolant can cause personal injury. Do not allow these products to remain in contact with the skin or eyes. Ingestion of these products or inhalation of fumes from these products can cause dizziness, nausea, vomiting, or poisoning. If exposure to any of these products occurs, or if any of these products are ingested or if fumes are inhaled, please consult the product's SDS for proper first aid or medical procedures. Failure to comply with the above warning could result in death or serious injury.

- 1) Turn off main power disconnect on main control box.
- 2) Close Ball Valve (1).

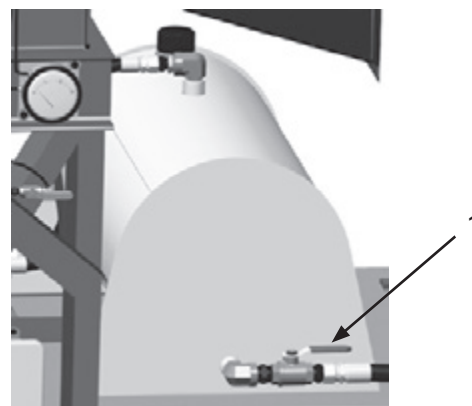

*Note: Drain hoses into container suitable for collecting fluids. Comply with all OSHA, local, City, State, Province, Country and jurisdiction regulations, ordinances and standards, related to your particular work area and environment.*

*Note: Label all hoses and connections to aid installation.*

- 3) Disconnect four Hydraulic Hoses (2).
- 4) Remove four Fittings (3).
- 5) Remove four Bolts (5) and Hydraulic Control Valve (4).
- 6) Install parts in reverse order.
- 7) Check hydraulic oil level, add as needed.
- 8) Activate Auger System and check for leaks. Repair as needed.

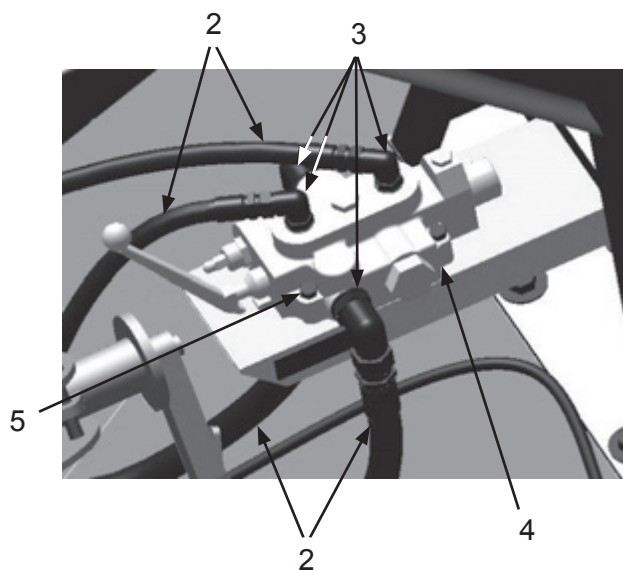



# MAINTENANCE

## Remove & Install Discharge Auger Hydraulic Motor

### WARNING

W-562

Always depressurize the entire system, disconnect all power sources and lockout/tagout all components before any maintenance or troubleshooting is attempted. Failure to comply with the above warning could cause electrical shock and inadvertent activation of equipment resulting in death or serious injury.

### WARNING

W-587

Escaping fluid under pressure can penetrate skin and tissue causing injury. Stop pump and relieve pressure before attempting maintenance or repair. Ensure all fittings are properly tightened before restoring pressure. If injury should occur, immediately seek medical attention. Failure to comply with the above warning could result in death or serious injury.

### WARNING

W-586

Moving parts can present an area where crushing, pinching, entanglement or amputation may occur. Do not place body parts or foreign objects in any area where there are moving parts. Failure to comply with the above warning could result in death or serious injury.

### WARNING

W-590

When performing service or maintenance on systems or devices requiring access from an elevated position, you must comply with all OSHA, local, City, State, Province, Country and jurisdiction regulations, ordinances and standards, as related to working in elevated work areas. Failure to comply with the above warning could result in death or serious injury.

- 1) Turn off main power disconnect on main control box.
- 2) Close Ball Valve (1).

*Note: Drain hoses into container suitable for collecting fluids. Comply with all OSHA, local, City, State, Province, Country and jurisdiction regulations, ordinances and standards, related to your particular work area and environment.*

*Note: Label all hoses and connections to aid installation.*

- 3) Disconnect two Hydraulic Hoses (4).
- 4) Remove three Bolts, and Washers (2) and Cover (3).

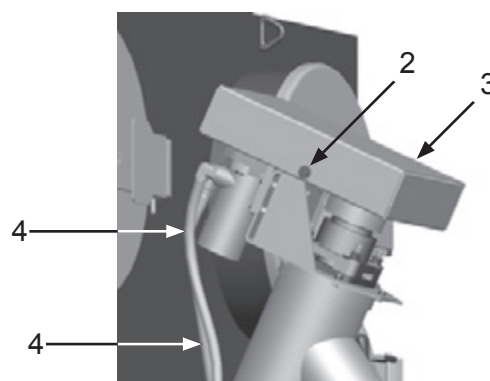
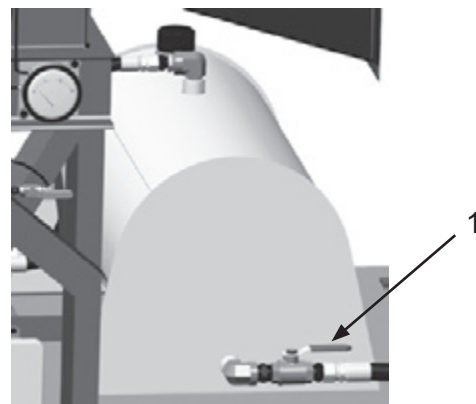

- 5) Loosen four Bolts (5) from Sliding Motor Mount (6).

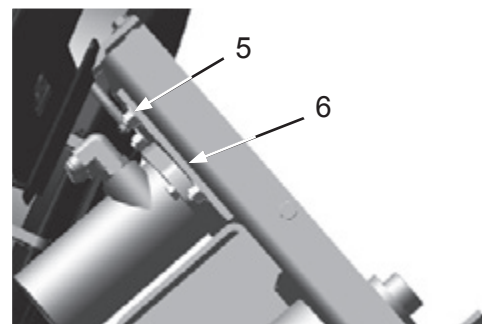

- 6) Remove Chain (7). Inspect for wear or damage. Replace as needed.

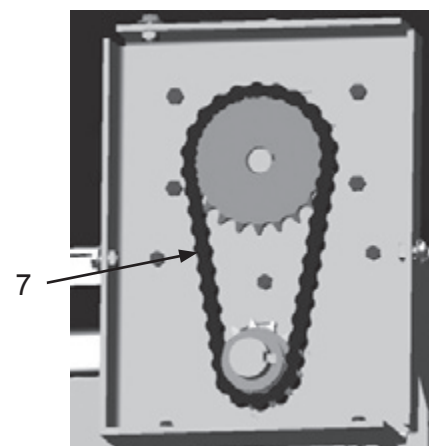



# MAINTENANCE

## Remove & Install Discharge Auger Hydraulic Motor (cont.)

### **WARNING**

W-562

Always depressurize the entire system, disconnect all power sources and lockout/tagout all components before any maintenance or troubleshooting is attempted. Failure to comply with the above warning could cause electrical shock and inadvertent activation of equipment resulting in death or serious injury.

### **WARNING**

W-567

Escaping fluid under pressure can penetrate skin and tissue causing injury. Stop pump and relieve pressure before attempting maintenance or repair. Ensure all fittings are properly tightened before restoring pressure. If injury should occur, immediately seek medical attention. Failure to comply with the above warning could result in death or serious injury.

### **WARNING**

W-589

Exposure to diesel fuel, lubricant grease and oil, hydraulic oil, or engine coolant can cause personal injury. Do not allow these products to remain in contact with the skin or eyes. Ingestion of these products or inhalation of fumes from these products can cause dizziness, nausea, vomiting, or poisoning. If exposure to any of these products occurs, or if any of these products are ingested or if fumes are inhaled, please consult the product's SDS for proper first aid or medical procedures. Failure to comply with the above warning could result in death or serious injury.

- 7) Remove Sprocket (8)

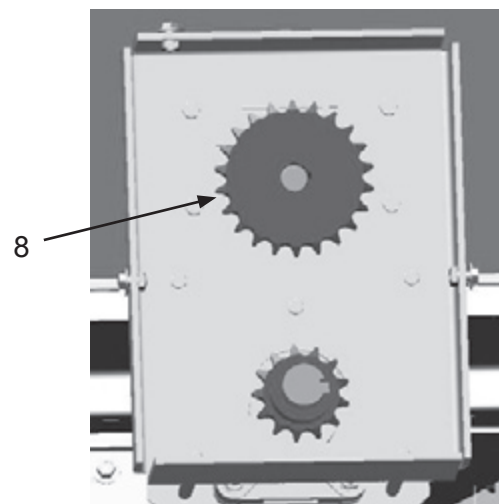

- 8) Remove two Bolts (9) and Hydraulic Motor (10). Repair or replace Hydraulic Motor as needed.
- 9) Install parts in reverse order using the following special instructions:
  - Tighten Bolts (9) in an alternating pattern. Tighten to 9 ft.-lb.
  - Ensure Chain has approximately 3/16 - 1/4 inch of deflection (See Adjust Discharge Auger Drive Chain).
- 10) Check hydraulic oil level (See Pre-Startup).
- 11) Activate Auger System and check for hydraulic oil leaks.

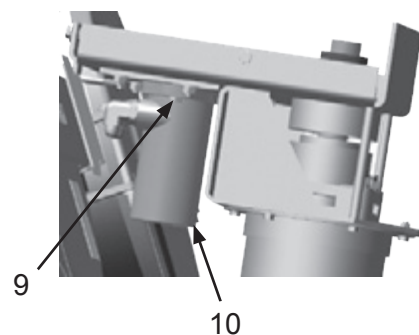

# MAINTENANCE

## Remove & Install Main Auger Hydraulic Motor

### **WARNING**

W-562

Always depressurize the entire system, disconnect all power sources and lockout/tagout all components before any maintenance or troubleshooting is attempted. Failure to comply with the above warning could cause electrical shock and inadvertent activation of equipment resulting in death or serious injury.

### **WARNING**

W-567

Escaping fluid under pressure can penetrate skin and tissue causing injury. Stop pump and relieve pressure before attempting maintenance or repair. Ensure all fittings are properly tightened before restoring pressure. If injury should occur, immediately seek medical attention. Failure to comply with the above warning could result in death or serious injury.

### **WARNING**

W-586

Moving parts can present an area where crushing, pinching, entanglement or amputation may occur. Do not place body parts or foreign objects in any area where there are moving parts. Failure to comply with the above warning could result in death or serious injury.

### **WARNING**

W-590

When performing service or maintenance on systems or devices requiring access from an elevated position, you must comply with all OSHA, local, City, State, Province, Country and jurisdiction regulations, ordinances and standards, as related to working in elevated work areas. Failure to comply with the above warning could result in death or serious injury.

- 1) Turn off main power disconnect on main control box.
- 2) Close Ball Valve (1).

*Note: Drain hoses into container suitable for collecting fluids. Comply with all OSHA, local, City, State, Province, Country and jurisdiction regulations, ordinances and standards, related to your particular work area and environment.*

*Note: Label all hoses and connections to aid installation.*

- 3) Remove two Hydraulic Hoses (2)
- 4) Loosen four Bolts (3).

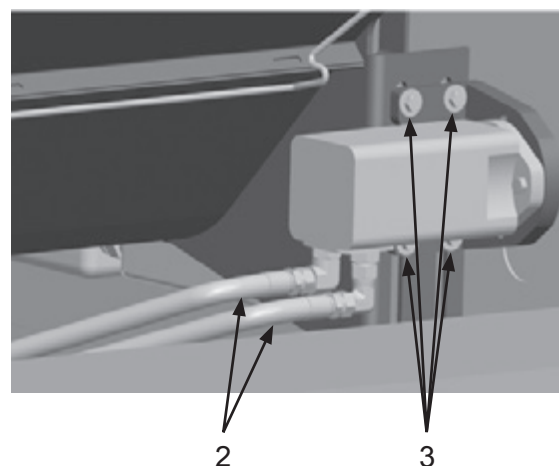
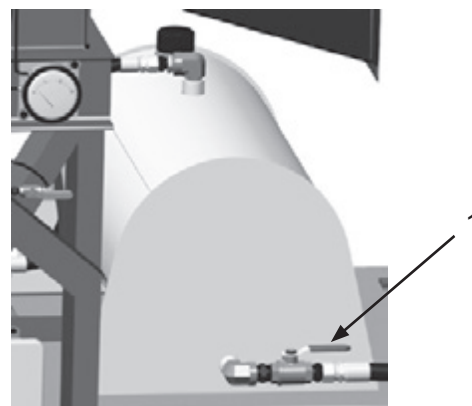

- 5) Remove four Bolts and Washers (5) and remove Cover (4).

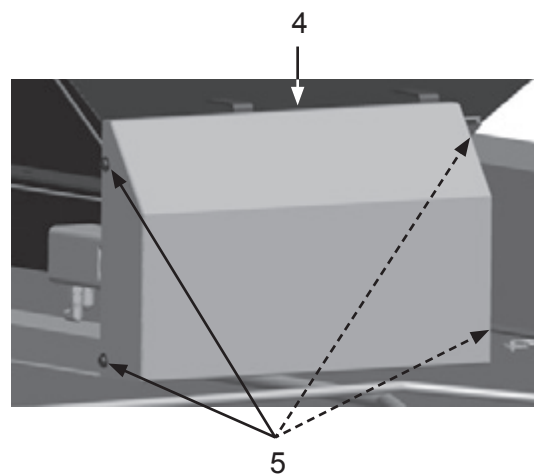

# MAINTENANCE

## Remove & Install Main Auger Hydraulic Motor (cont.)

### **WARNING**

W-562

Always depressurize the entire system, disconnect all power sources and lockout/tagout all components before any maintenance or troubleshooting is attempted. Failure to comply with the above warning could cause electrical shock and inadvertent activation of equipment resulting in death or serious injury.

### **WARNING**

W-586

Moving parts can present an area where crushing, pinching, entanglement or amputation may occur. Do not place body parts or foreign objects in any area where there are moving parts. Failure to comply with the above warning could result in death or serious injury.

- 6) Remove Chain (6).

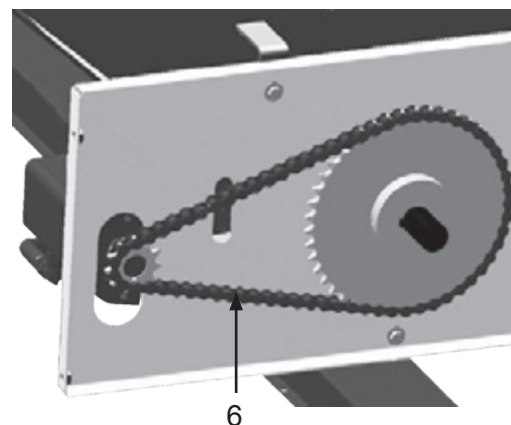

- 7) Remove Sprocket (7).

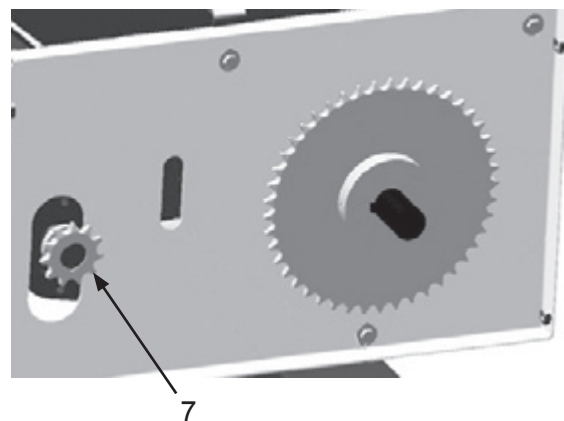

- 8) Remove two Fittings (8).
- 9) Remove two Bolts (10) and Hydraulic Motor (9). Repair or replace Hydraulic Motor as needed.
- 10) Install parts in reverse order using the following special instructions:
  - Ensure Chain has approximately 5/8 - 7/8 inch of deflection (See Adjust Main Auger Drive Chain).
- 11) Check hydraulic oil level (See Pre-Startup).
- 12) Operate Auger System and check for hydraulic oil leaks and Auger System function.

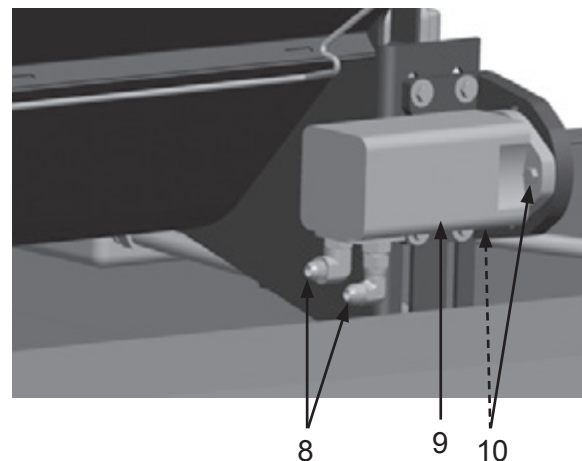

# MAINTENANCE

## Remove & Install Fan Drive Belt Assembly

### **⚠ WARNING**

W-562

Always depressurize the entire system, disconnect all power sources and lockout/tagout all components before any maintenance or troubleshooting is attempted. Failure to comply with the above warning could cause electrical shock and inadvertent activation of equipment resulting in death or serious injury.

### **⚠ WARNING**

W-586

Moving parts can present an area where crushing, pinching, entanglement or amputation may occur. Do not place body parts or foreign objects in any area where there are moving parts. Failure to comply with the above warning could result in death or serious injury.

### **⚠ WARNING**

W-590

When performing service or maintenance on systems or devices requiring access from an elevated position, you must comply with all OSHA, local, City, State, Province, Country and jurisdiction regulations, ordinances and standards, as related to working in elevated work areas. Failure to comply with the above warning could result in death or serious injury.

- 1) Turn off main power disconnect on main control box.
- 2) Remove eight Bolts and Washers (1).
- 3) Remove Upper Belt Cover (2).
- 4) Remove Lower Belt Cover (3).

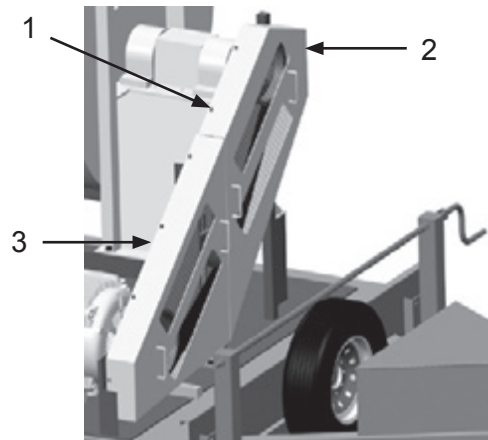

- 5) Loosen two Bolts (5) and turn Nut (6) until Belt (4) is loose enough to remove. Remove belt.
- 6) Inspect Belt (4) for wear, abrasion, and damage. Replace as needed.

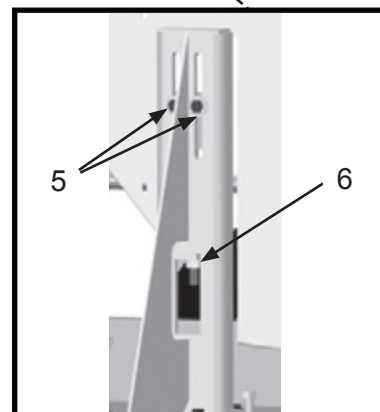
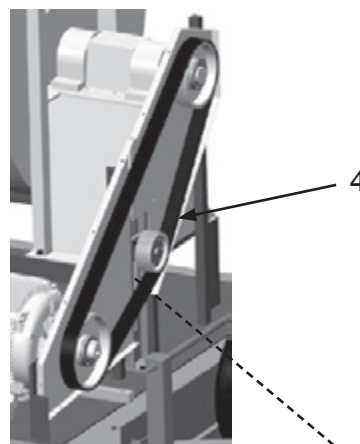

# MAINTENANCE

## Remove & Install Fan Drive Belt Assembly (cont.)

### **WARNING**

W-562

Always depressurize the entire system, disconnect all power sources and lockout/tagout all components before any maintenance or troubleshooting is attempted. Failure to comply with the above warning could cause electrical shock and inadvertent activation of equipment resulting in death or serious injury.

### **WARNING**

W-566

Moving parts can present an area where crushing, pinching, entanglement or amputation may occur. Do not place body parts or foreign objects in any area where there are moving parts. Failure to comply with the above warning could result in death or serious injury.

- 7) Remove three Bolts and Lock Washers (12) and Bushing (11).
- 8) Remove key and Sheave (10) from shaft.
- 9) Remove three Bolts and Lock Washers (12) and Idler Bushing (14).
- 10) Remove Sheave (13).
- 11) Remove three Bolts and Lock Washers (12) and Bushing (16).
- 12) Remove key and Sheave (15) from shaft.
- 13) Remove 10 Bolts, 20 Washers, 10 Lock Washers and 10 Nuts (8) from Belt Guard Back (7,9).
- 14) Remove Belt Guard Backs (7,9).

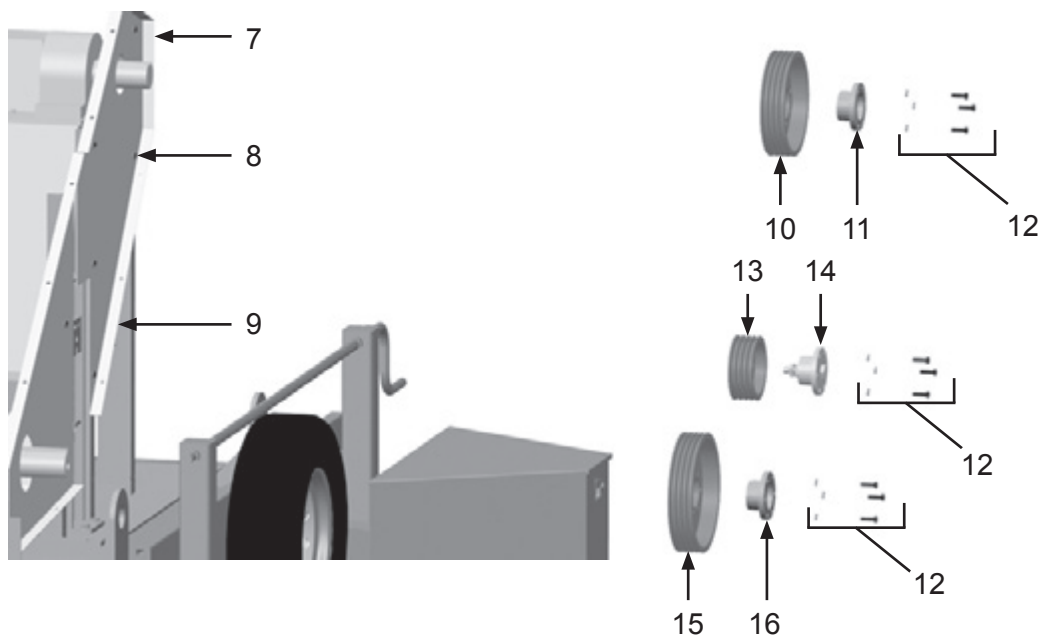

- 15) Remove five Bolts, Washers, and Nuts (17).
- 16) Remove Bracket (18).
- 17) Install parts in reverse order using the following special instructions:
  - Adjust fan drive belt tension. See Adjust Tension of Fan Drive Belt.

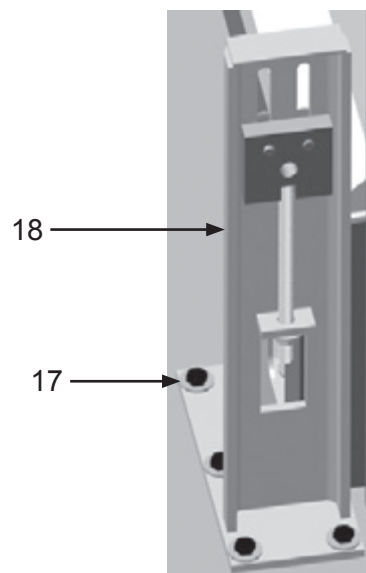



# MAINTENANCE

## Remove & Install Discharge Auger Assembly

### **WARNING**

W-562

Always depressurize the entire system, disconnect all power sources and lockout/tagout all components before any maintenance or troubleshooting is attempted. Failure to comply with the above warning could cause electrical shock and inadvertent activation of equipment resulting in death or serious injury.

### **WARNING**

W-587

Escaping fluid under pressure can penetrate skin and tissue causing injury. Stop pump and relieve pressure before attempting maintenance or repair. Ensure all fittings are properly tightened before restoring pressure. If injury should occur, immediately seek medical attention. Failure to comply with the above warning could result in death or serious injury.

### **WARNING**

W-589

Exposure to diesel fuel, lubricant grease and oil, hydraulic oil, or engine coolant can cause personal injury. Do not allow these products to remain in contact with the skin or eyes. Ingestion of these products or inhalation of fumes from these products can cause dizziness, nausea, vomiting, or poisoning. If exposure to any of these products occurs, or if any of these products are ingested or if fumes are inhaled, please consult the product's SDS for proper first aid or medical procedures. Failure to comply with the above warning could result in death or serious injury.

- 1) Turn off main power disconnect on main control box.
- 2) Close Ball Valve (1).

*Note: Drain hoses into container suitable for collecting fluids. Comply with all OSHA, local, City, State, Province, Country and jurisdiction regulations, ordinances and standards, related to your particular work area and environment.*

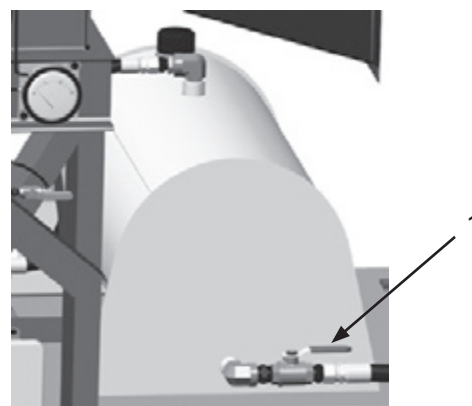

*Note: Label all hoses and connections to aid installation.*

- 3) Disconnect two Hydraulic Hoses (2).
- 4) Route Hydraulic Hoses away from Discharge Auger Assembly.

*Note: Approximate weight of Discharge Auger Assembly is 180 lbs. Use suitable lifting devices to support or maneuver Discharge Auger Assembly.*

- 5) Attach a suitable lifting device to Discharge Auger Assembly (3).

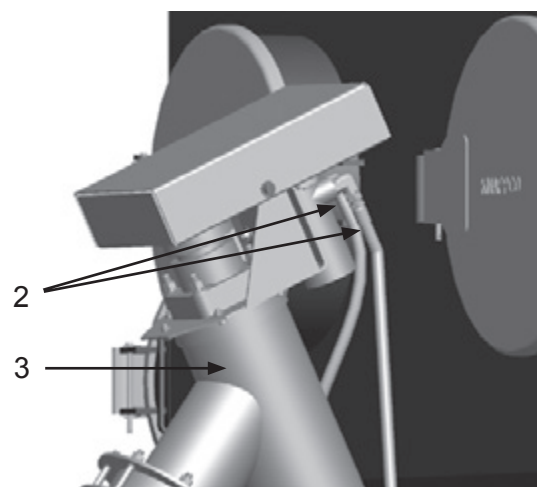

- 6) Remove six Bolts and Washers (4).
- 7) Remove Cover and Gasket (5). Inspect Gasket for wear or damage. Replace as needed.
- 8) Repeat for opposite side.

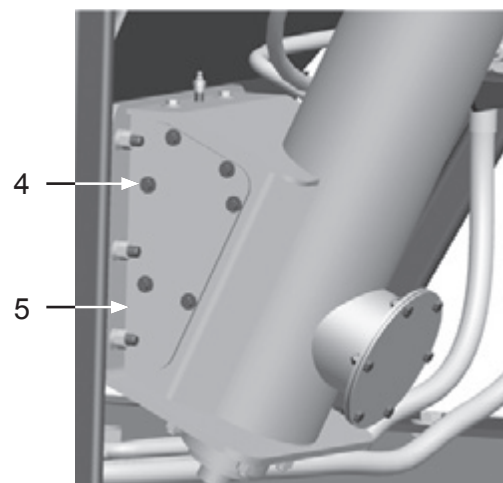



# MAINTENANCE

## Remove & Install Discharge Auger Assembly (cont.)

### **WARNING**

W-562

Always depressurize the entire system, disconnect all power sources and lockout/tagout all components before any maintenance or troubleshooting is attempted. Failure to comply with the above warning could cause electrical shock and inadvertent activation of equipment resulting in death or serious injury.

### **WARNING**

W-590

When performing service or maintenance on systems or devices requiring access from an elevated position, you must comply with all OSHA, local, City, State, Province, Country and jurisdiction regulations, ordinances and standards, as related to working in elevated work areas. Failure to comply with the above warning could result in death or serious injury.

- 9) Remove two Bolts and Nuts (9).
- 10) Remove Grease Fitting (7).
- 11) Remove two Bolts and Washers (6).
- 12) Remove Bearing Hanger Assembly (8).

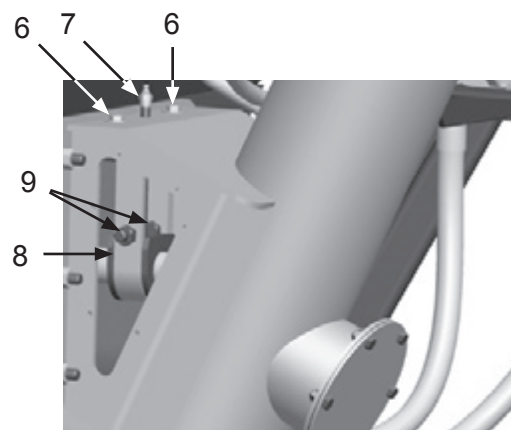

- 13) Route hydraulic hose (10) away from Discharge Auger Assembly.



- 14) Remove six Nuts, Lock Washers, Flat Washers and Bolts (11).
- 15) Remove two Bolts, Washers, and Nuts (14).
- 16) Raise and remove Discharge Auger Assembly.
- 17) Remove two Bolts, Washers, and, Nuts (12), and Bracket (13).
- 18) Install parts in reverse order.
- 19) Check hydraulic oil level. (See Pre-Startup).
- 20) Activate Auger System and check for hydraulic oil leaks. Repair as needed.

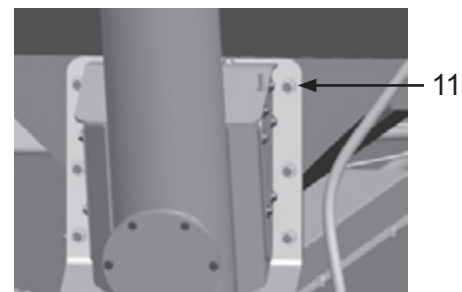

# MAINTENANCE

## Remove & Install Main Auger

### **WARNING**

W-562

Always depressurize the entire system, disconnect all power sources and lockout/tagout all components before any maintenance or troubleshooting is attempted. Failure to comply with the above warning could cause electrical shock and inadvertent activation of equipment resulting in death or serious injury.

### **WARNING**

W-586

Moving parts can present an area where crushing, pinching, entanglement or amputation may occur. Do not place body parts or foreign objects in any area where there are moving parts. Failure to comply with the above warning could result in death or serious injury.

- 1) Turn off main power disconnect on main control box.
- 2) Close Ball Valve (1).
- 3) Remove Discharge Auger Assembly. See Remove & Install Discharge Auger Assembly.
- 4) Loosen four Bolts (2).

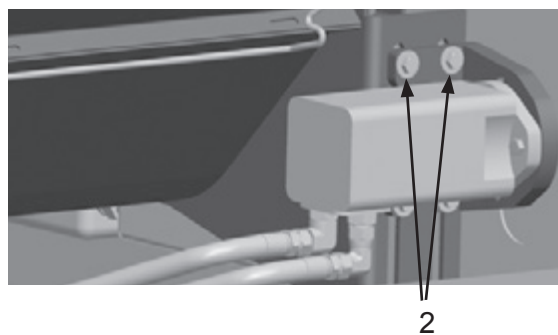
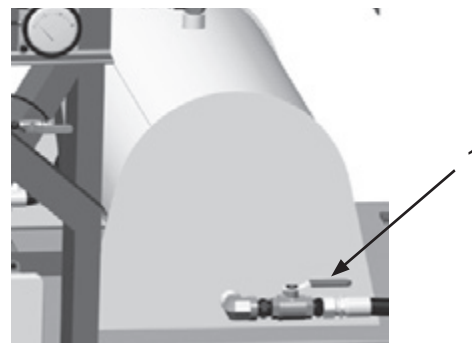

- 5) Remove four Bolts and Washers (4) and remove Cover (3).

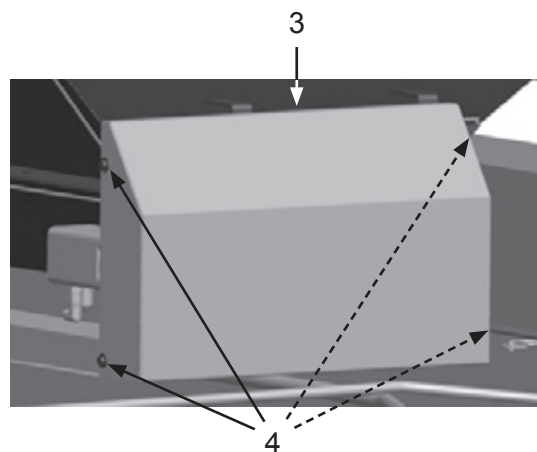

- 6) Remove Chain (5).

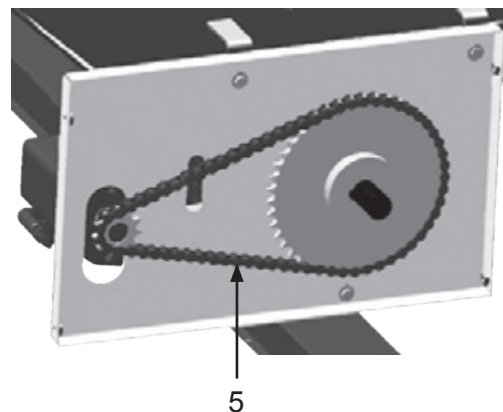

# MAINTENANCE

## Remove & Install Main Auger (cont.)

### **WARNING**

W-562

Always depressurize the entire system, disconnect all power sources and lockout/tagout all components before any maintenance or troubleshooting is attempted. Failure to comply with the above warning could cause electrical shock and inadvertent activation of equipment resulting in death or serious injury.

### **WARNING**

W-586

Moving parts can present an area where crushing, pinching, entanglement or amputation may occur. Do not place body parts or foreign objects in any area where there are moving parts. Failure to comply with the above warning could result in death or serious injury.

- 7) Loosen two Set Screws (7) and remove Sprocket (6).
- 8) Remove Sprocket (8).

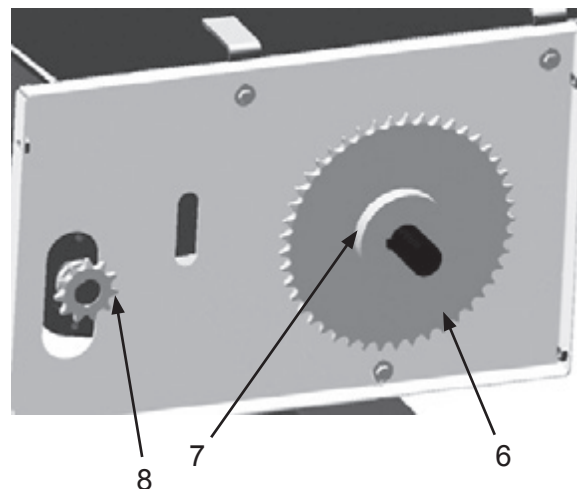

- 9) Remove three Bolts and Washers (10).
- 10) Remove Back Cover (9).

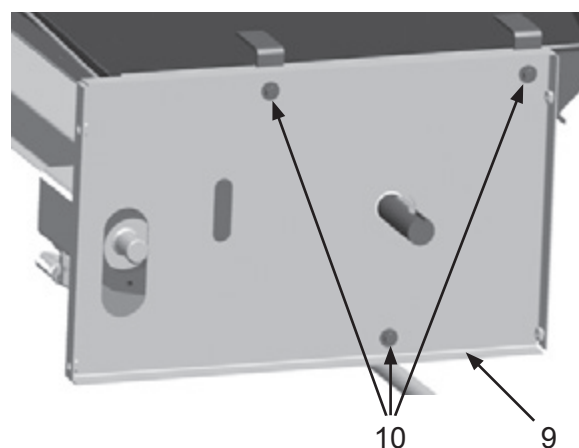

- 11) Remove Key (13).
- 12) Remove Snap Ring (15).
- 13) Rotate Shaft (14) until two Set Screws (11) are visible in the slots. Loosen two Set Screws.
- 14) Remove four Nuts and Washers (16).
- 15) Remove Thrust Bearing (12).

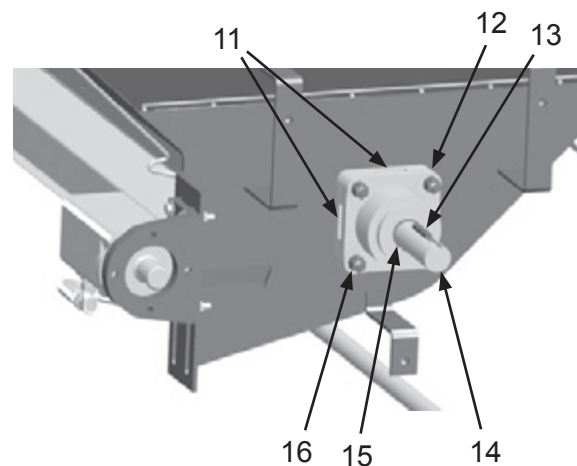

# MAINTENANCE

## Remove & Install Main Auger (cont.)

### **WARNING**

W-562

Always depressurize the entire system, disconnect all power sources and lockout/tagout all components before any maintenance or troubleshooting is attempted. Failure to comply with the above warning could cause electrical shock and inadvertent activation of equipment resulting in death or serious injury.

### **WARNING**

W-586

Moving parts can present an area where crushing, pinching, entanglement or amputation may occur. Do not place body parts or foreign objects in any area where there are moving parts. Failure to comply with the above warning could result in death or serious injury.

- 16) Remove Snap Ring (18) and Seal Plate (17).

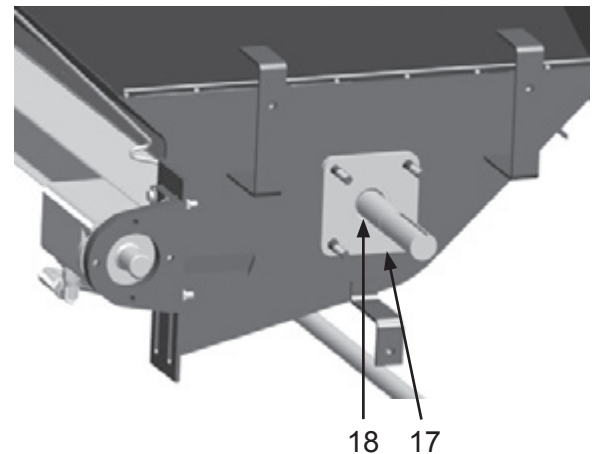

- 17) Remove twelve Bolts and Washers (19) and Access Panel (20).

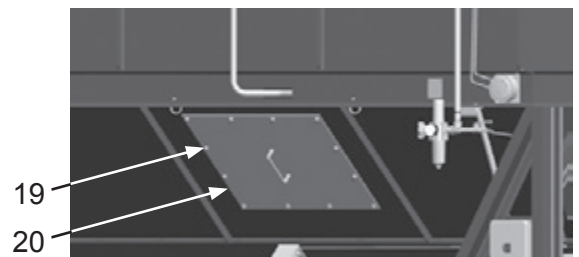

- 18) Remove four Retaining Brackets (21) and Grate (22).

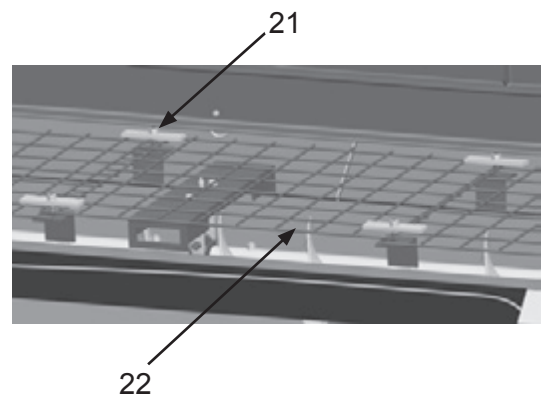

# MAINTENANCE

## Remove & Install Main Auger (cont.)

### **WARNING**

W-562

Always depressurize the entire system, disconnect all power sources and lockout/tagout all components before any maintenance or troubleshooting is attempted. Failure to comply with the above warning could cause electrical shock and inadvertent activation of equipment resulting in death or serious injury.

- 19) Remove Grease Zerk (24).
- 20) Remove two Bolts and Washers (23).
- 21) Remove Bolt and Bearing Hanger (25).

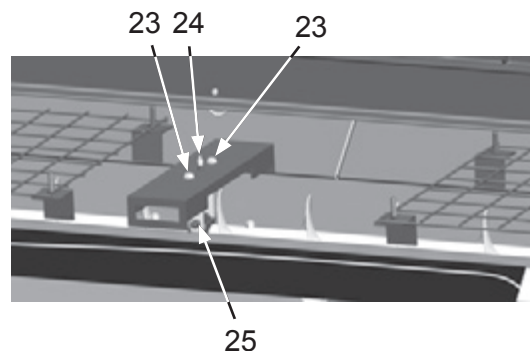

### **WARNING**

W-586

Moving parts can present an area where crushing, pinching, entanglement or amputation may occur. Do not place body parts or foreign objects in any area where there are moving parts. Failure to comply with the above warning could result in death or serious injury.

- 22) Remove two Bolts, Washers and Nuts (26).
- Note: Approximate weight of Main Auger is 105 pounds. Use suitable lifting devices to support or maneuver Main Auger.*

- 23) Remove Main Auger (27).

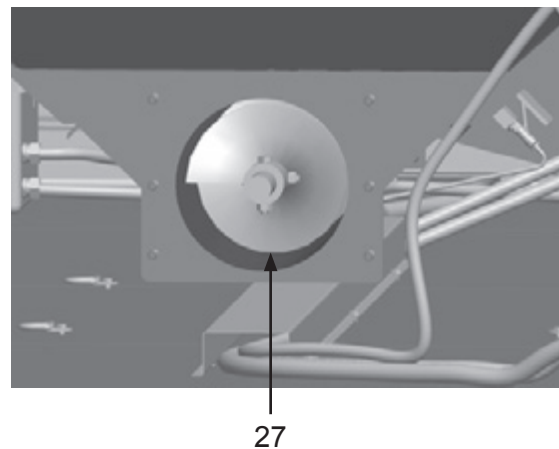
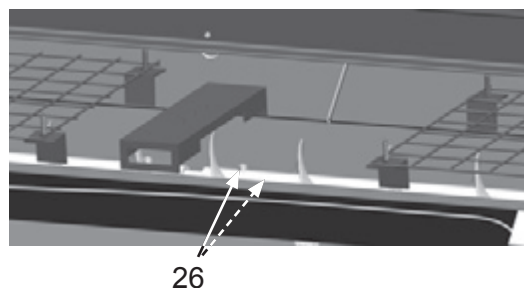

- 24) Install parts in reverse order using the following special instructions:
  - Ensure Chain (28) has approximately 5/8 - 7/8 inch of deflection. Adjust as needed. (See Adjust Main Auger Drive Chain).

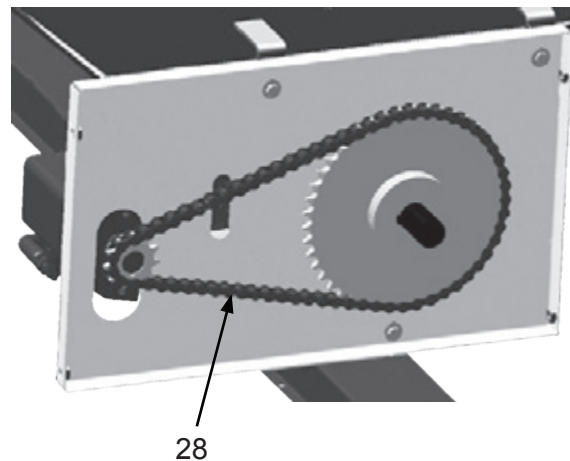

# MAINTENANCE

## Remove & Install Discharge Auger

### **⚠ WARNING**

W-562

Always depressurize the entire system, disconnect all power sources and lockout/tagout all components before any maintenance or troubleshooting is attempted. Failure to comply with the above warning could cause electrical shock and inadvertent activation of equipment resulting in death or serious injury.

### **⚠ WARNING**

W-586

Moving parts can present an area where crushing, pinching, entanglement or amputation may occur. Do not place body parts or foreign objects in any area where there are moving parts. Failure to comply with the above warning could result in death or serious injury.

- 1) Turn off main power disconnect on main control box.
- 2) Close Ball Valve (1).
- 3) Remove Discharge Auger Assembly. See Remove & Install Discharge Auger Assembly.
- 4) Remove three Bolts (2) and Chain Drive Cover (1).

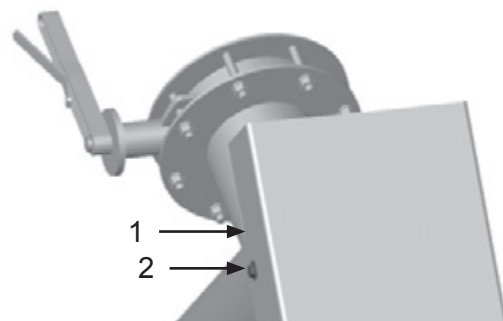
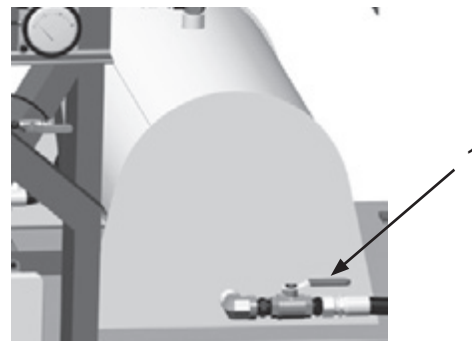

- 5) Loosen four Bolts (3).

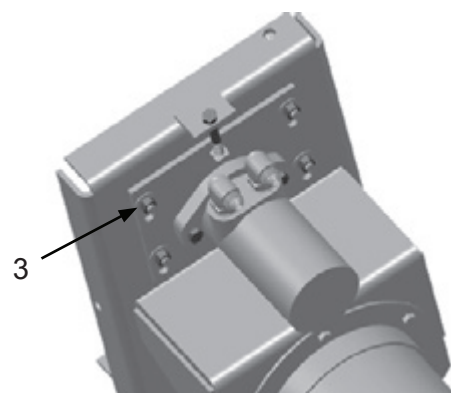

- 6) Remove Chain (4). Inspect for wear or damage. Replace as needed.
- 7) Remove Sprocket (6).
- 8) Loosen two Set Screws (7) retaining Sprocket (5) to shaft and remove Sprocket. Inspect Sprocket for wear or damage. Replace as needed.

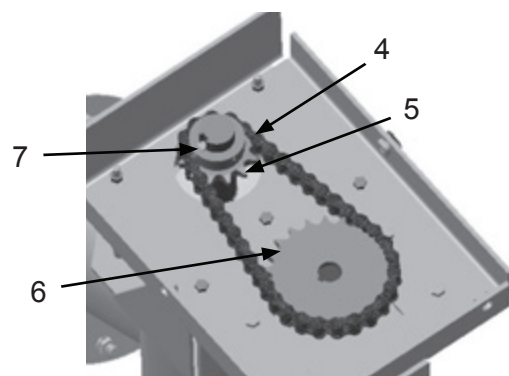



# MAINTENANCE

## Remove & Install Discharge Auger (cont.)

### **WARNING**

W-562

Always depressurize the entire system, disconnect all power sources and lockout/tagout all components before any maintenance or troubleshooting is attempted. Failure to comply with the above warning could cause electrical shock and inadvertent activation of equipment resulting in death or serious injury.

- 9) Remove four Nuts (8) and Bearing (9).

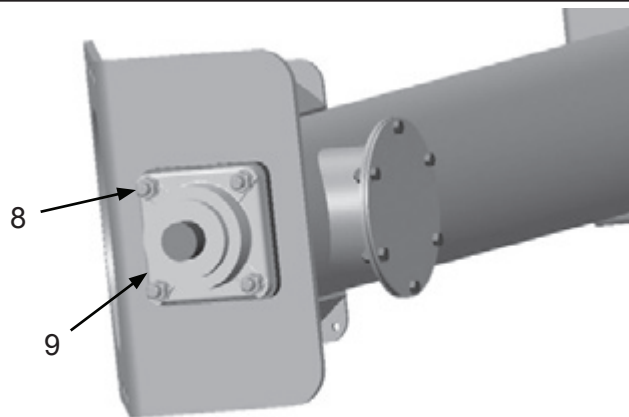

- 10) Remove three Bolts (11); two Nuts, Bolts and Spacers (10) and Chain Guard Bottom Cover (12).

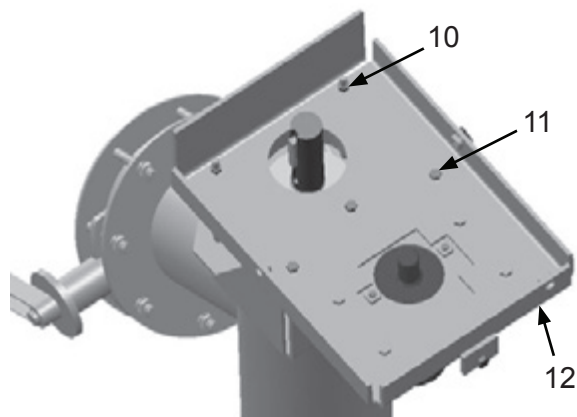

- 11) Rotate shaft (13) until two Set Screws (15) are visible, and loosen Set Screws.  
12) Remove Snap Ring (14).  
13) Remove four Nuts and Lock Washers (17), and Bearing Housing (16).

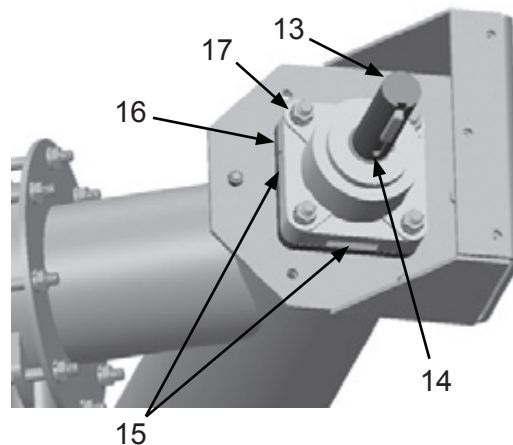

# MAINTENANCE

## Remove & Install Discharge Auger (cont.)

### **WARNING**

W-562

Always depressurize the entire system, disconnect all power sources and lockout/tagout all components before any maintenance or troubleshooting is attempted. Failure to comply with the above warning could cause electrical shock and inadvertent activation of equipment resulting in death or serious injury.

- 1) Remove Snap Ring (18) and Seal Plate (19).
- 2) Remove four Bolts, Washers, and Nuts (20).
- 3) Remove Shaft Cover (21).

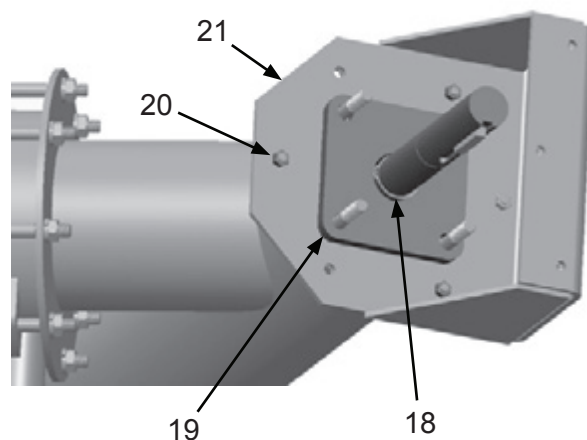

### **WARNING**

W-586

Moving parts can present an area where crushing, pinching, entanglement or amputation may occur. Do not place body parts or foreign objects in any area where there are moving parts. Failure to comply with the above warning could result in death or serious injury.

*Note: Approximate weight of Discharge Auger is 60 pounds. Use suitable lifting devices to support or maneuver Discharge Auger.*

- 4) Remove Discharge Auger (22).

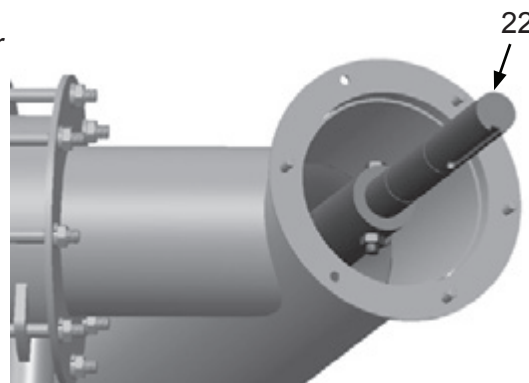

- 5) Remove two Bolts and Nuts (23) and Shaft End (24). Repeat for opposite end.

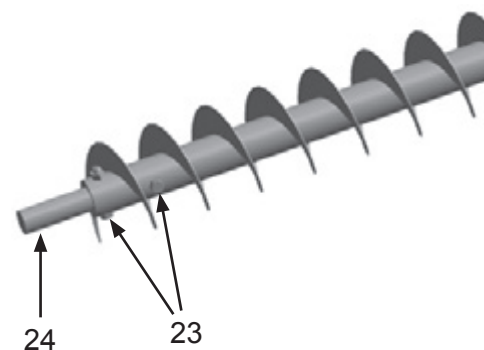

## MAINTENANCE

### Remove & Install Discharge Auger (cont.)

---

#### **⚠ WARNING**

W-562

Always depressurize the entire system, disconnect all power sources and lockout/tagout all components before any maintenance or troubleshooting is attempted. Failure to comply with the above warning could cause electrical shock and inadvertent activation of equipment resulting in death or serious injury.

#### **⚠ WARNING**

W-586

Moving parts can present an area where crushing, pinching, entanglement or amputation may occur. Do not place body parts or foreign objects in any area where there are moving parts. Failure to comply with the above warning could result in death or serious injury.

- 6) Install parts in reverse order using the following special instructions:
  - Tighten four Bolts (25) in an alternating pattern. Tighten to 9 ft.-lb.
  - Ensure Chain has approximately 3/16 - 1/4 inch of deflection (See Adjust Discharge Auger Drive Chain).
- 7) Check hydraulic oil level. (See Pre-Startup).
- 8) Activate Auger System and check for hydraulic oil leaks.

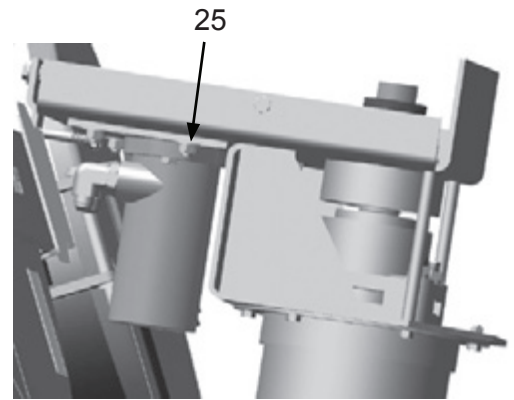

# MAINTENANCE

## Remove & Install Fan

### **WARNING**

W-562

Always depressurize the entire system, disconnect all power sources and lockout/tagout all components before any maintenance or troubleshooting is attempted. Failure to comply with the above warning could cause electrical shock and inadvertent activation of equipment resulting in death or serious injury.

### **WARNING**

W-586

Moving parts can present an area where crushing, pinching, entanglement or amputation may occur. Do not place body parts or foreign objects in any area where there are moving parts. Failure to comply with the above warning could result in death or serious injury.

### **WARNING**

W-590

When performing service or maintenance on systems or devices requiring access from an elevated position, you must comply with all OSHA, local, City, State, Province, Country and jurisdiction regulations, ordinances and standards, as related to working in elevated work areas. Failure to comply with the above warning could result in death or serious injury.

- 1) Turn off main power disconnect on main control box.
- 2) Remove Fan Drive Belt Cover (1) Assembly (See Remove & Install Fan Drive Belt Assembly).

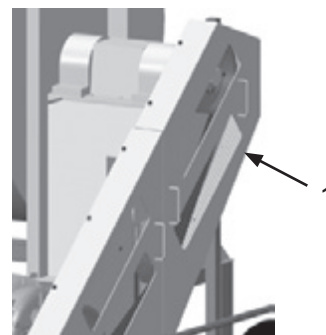

- 3) Remove 12 Bolts, Washers, and Nuts (2). Remove screen (3).

*Note: Approximate weight of fan exhaust is 195 lbs. Use suitable lifting devices to support or maneuver hydraulic oil tank stand.*

- 4) Attach a suitable lifting device to Fan Exhaust (5).
- 5) Remove 10 Bolts, 20 Washers, 10 Lock Washers and 10 Nuts (4). Remove Fan Exhaust (5).

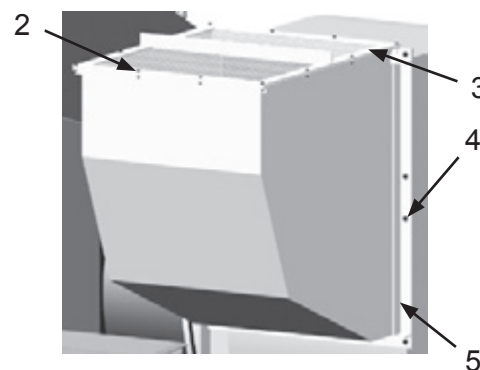

- 6) Remove two Clamps (7) and Rubber Connection Gasket (6).
- 7) Remove Hose Clamp (12), Hose (10), Toe Nipple (11), and Bushing (9).

*Note: Approximate weight of fan is 2050 lbs. Use suitable lifting devices to support or maneuver fan.*

- 8) Attach a suitable lifting device to Fan and remove Six Bolts, Washers, Lock Washers and Nuts (8). Remove Fan.
- 9) Install parts in reverse order.

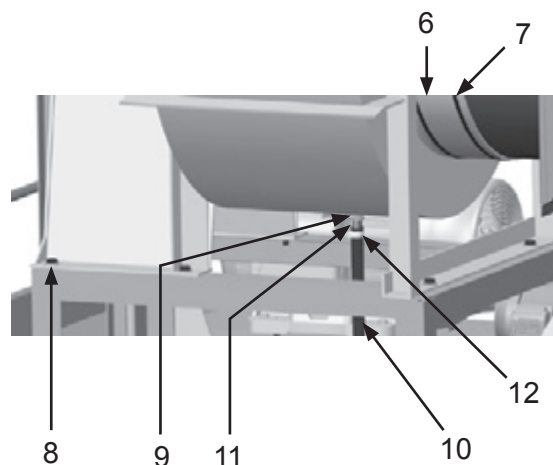

# MAINTENANCE

## Remove & Install Pulsar Solenoid

### **WARNING**

W-562

Always depressurize the entire system, disconnect all power sources and lockout/tagout all components before any maintenance or troubleshooting is attempted. Failure to comply with the above warning could cause electrical shock and inadvertent activation of equipment resulting in death or serious injury.

### **WARNING**

W-590

When performing service or maintenance on systems or devices requiring access from an elevated position, you must comply with all OSHA, local, City, State, Province, Country and jurisdiction regulations, ordinances and standards, as related to working in elevated work areas. Failure to comply with the above warning could result in death or serious injury.

### **NOTICE**

N-530

Label all hoses and connections to aid installation.

- 1) Disconnect air hose from filter/regulator.
- 2) Loosen Screw (2) and remove Cover (1).

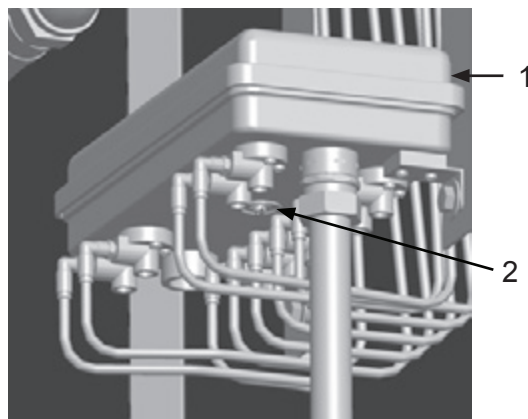

- 3) Disconnect Wire (6) and Wire (5).
- 4) Remove Retaining Clip (3).
- 5) Remove Operator (4).

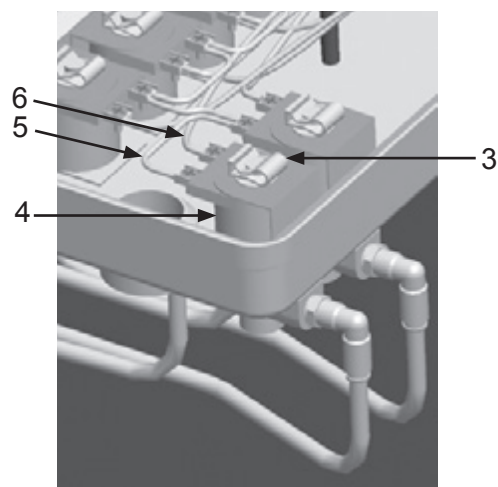

- 6) Disconnect Tubing (8).
- 7) Remove Fitting (7).
- 8) Remove Nut (10) and Valve (9).
- 9) Install parts in reverse order.

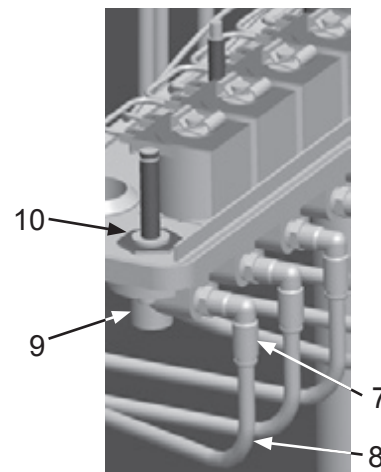

# MAINTENANCE

## Remove & Install Pulser Manifold

### **WARNING**

W-562

Always depressurize the entire system, disconnect all power sources and lockout/tagout all components before any maintenance or troubleshooting is attempted. Failure to comply with the above warning could cause electrical shock and inadvertent activation of equipment resulting in death or serious injury.

### **WARNING**

W-590

When performing service or maintenance on systems or devices requiring access from an elevated position, you must comply with all OSHA, local, City, State, Province, Country and jurisdiction regulations, ordinances and standards, as related to working in elevated work areas. Failure to comply with the above warning could result in death or serious injury.

### **NOTICE**

N-530

Label all hoses and connections to aid installation.

- 1) Disconnect air hose from filter/regulator.
- 2) Disconnect Air Hose (3).
- 3) Remove Ball Valve (4) and Needle Valve (5).
- 4) Remove Clamp (2).
- 5) Remove Filter/Regulator (1).

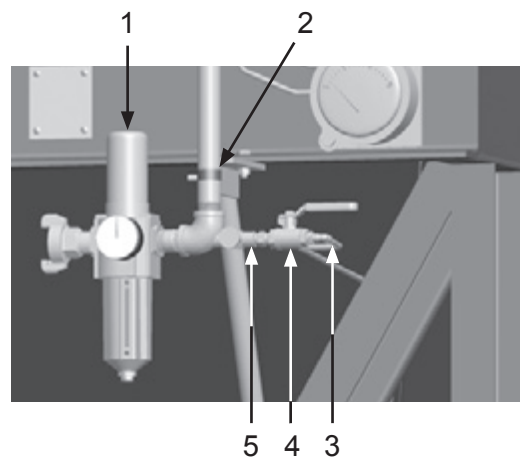

- 6) Disconnect Hose (10).
- 7) Remove Close Nipple (11).
- 8) Remove Ball Valve (12).
- 9) Remove Pipe Tee (13).
- 10) Remove Pipe Nipple (14).
- 11) Remove Close Nipple (9).
- 12) Remove Street Elbow (8).
- 13) Attach a suitable support to Bracket (7).
- 14) Remove two U-bolts (6).
- 15) Place and support Bracket (7) so it is clear of the area.

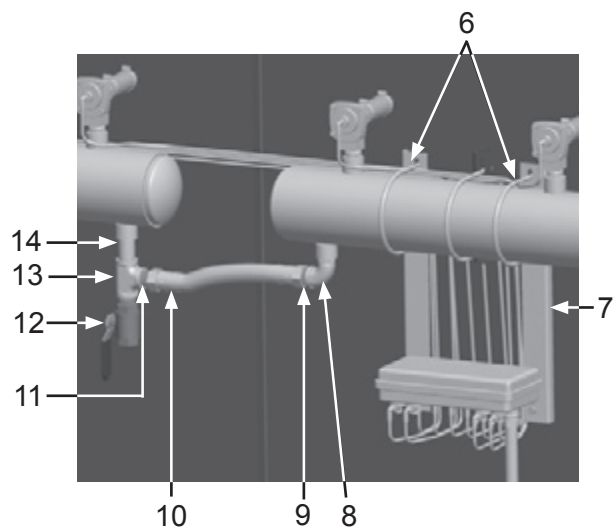

- 16) Remove Pipe (16) and Bushing (15).

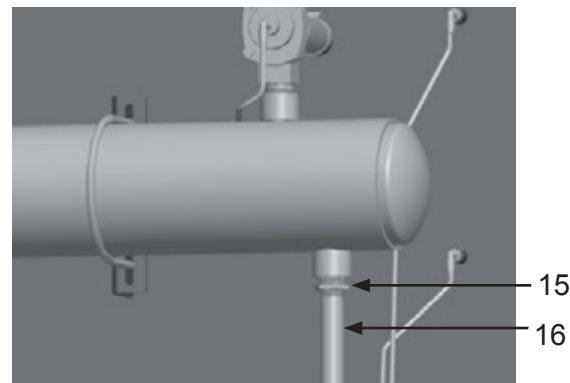



# MAINTENANCE

## Remove & Install Pulser Manifold (cont.)

### **WARNING**

W-562  
Always depressurize the entire system, disconnect all power sources and lockout/tagout all components before any maintenance or troubleshooting is attempted. Failure to comply with the above warning could cause electrical shock and inadvertent activation of equipment resulting in death or serious injury.

### **WARNING**

W-590  
When performing service or maintenance on systems or devices requiring access from an elevated position, you must comply with all OSHA, local, City, State, Province, Country and jurisdiction regulations, ordinances and standards, as related to working in elevated work areas. Failure to comply with the above warning could result in death or serious injury.

- 17) Disconnect Urethane Tubing (20).
- 18) Remove Fitting (21).
- 19) Loosen two Clamps (17) and disconnect Hose (18) from Diaphragm Valve (22).
- 20) Remove Diaphragm Valve (22).
- 21) Remove Nipple (19).
- 22) Route Urethane Tubing (20) away from manifold.
- 23) Repeat for remaining Diaphragm Valves.

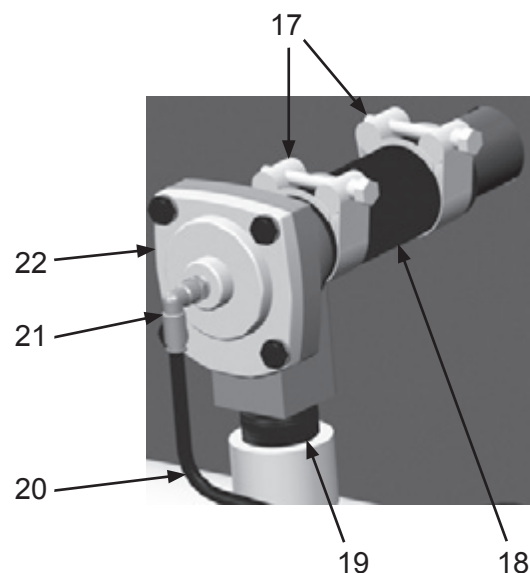

*Note: Approximate weight of Front Pulser Manifold is 120 pounds. Use suitable lifting devices to support or maneuver Front Pulser Manifold.*

- 24) Attach suitable lifting devices to Pulser Manifold (23).
- 25) Remove three U-bolts (24) and remove Pulser Manifold (23).

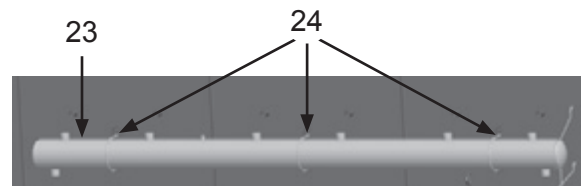

*Note: Approximate weight of Rear Pulser Manifold is 75 pounds. Use suitable lifting devices to support or maneuver Rear Pulser Manifold.*

- 26) Attach suitable lifting devices to Pulser Manifold (25).
- 27) Remove Pipe Plug (27).
- 28) Remove two U-bolts (26) and remove Pulser Manifold (25).
- 29) Install parts in reverse order.

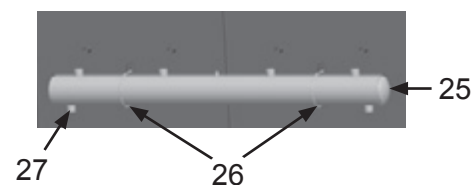

# MAINTENANCE

## Remove & Install Timer Board

### WARNING

W-562

Always depressurize the entire system, disconnect all power sources and lockout/tagout all components before any maintenance or troubleshooting is attempted. Failure to comply with the above warning could cause electrical shock and inadvertent activation of equipment resulting in death or serious injury.

### NOTICE

N-530

Label all hoses and connections to aid installation.

- 1) Turn off main power disconnect on main control box.
- 2) Open enclosure door.
- 3) Remove four Screws (1).
- 4) Record connection location and label Wires (2).
- 5) Disconnect Wires (2).

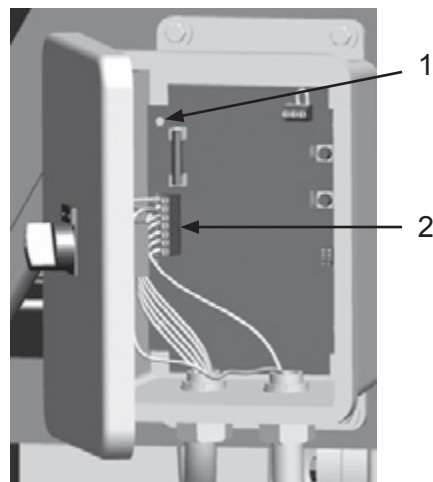

- 6) Install parts in reverse order using the chart as a guide.
- 7) Adjust pulse duration and pulse separation. See Adjust Pulse Separation.

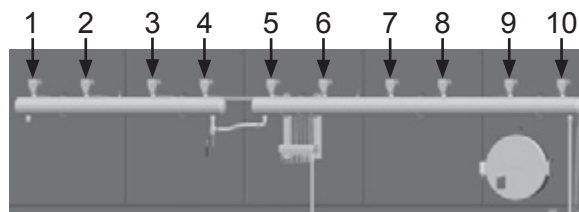
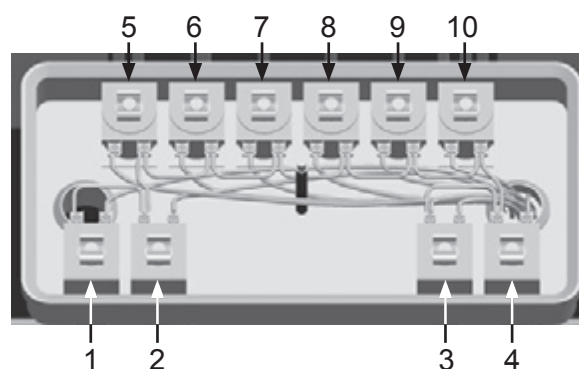
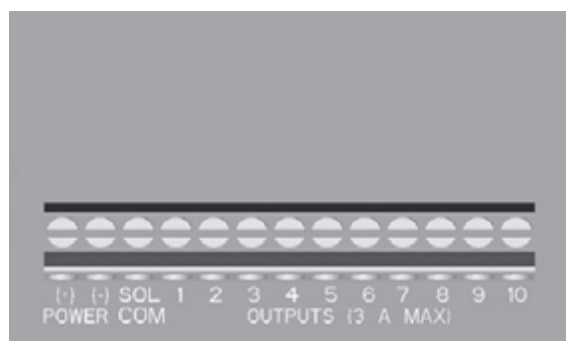

# MAINTENANCE

## Remove & Install Dust Collector Filter Cartridge Hatch Assembly

### WARNING

W-562

Always depressurize the entire system, disconnect all power sources and lockout/tagout all components before any maintenance or troubleshooting is attempted. Failure to comply with the above warning could cause electrical shock and inadvertent activation of equipment resulting in death or serious injury.

### WARNING

W-586

Moving parts can present an area where crushing, pinching, entanglement or amputation may occur. Do not place body parts or foreign objects in any area where there are moving parts. Failure to comply with the above warning could result in death or serious injury.

### WARNING

W-590

When performing service or maintenance on systems or devices requiring access from an elevated position, you must comply with all OSHA, local, City, State, Province, Country and jurisdiction regulations, ordinances and standards, as related to working in elevated work areas. Failure to comply with the above warning could result in death or serious injury.

- 1) Loosen Handles (1).
- 2) Rotate Latch Bars (2) 90° to clear hatch door.
- 3) Open hatch door.

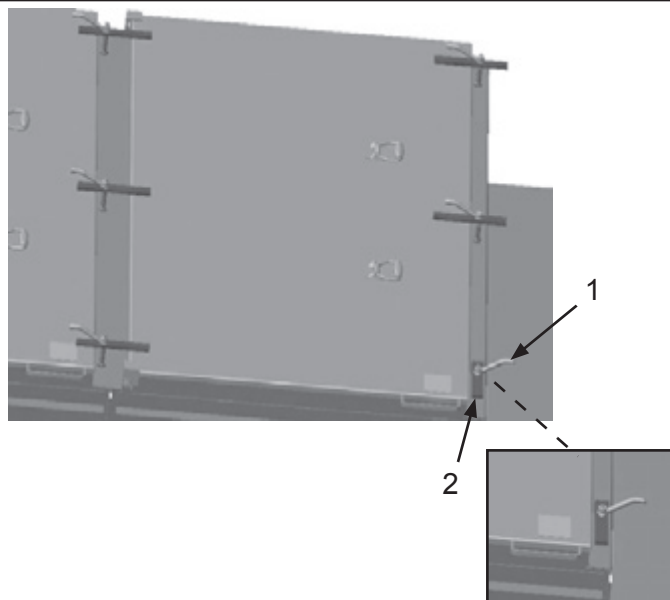

- 4) Remove two Hex Nuts (3).
- 5) Remove Gas Spring (4).
- 6) Repeat for other side.

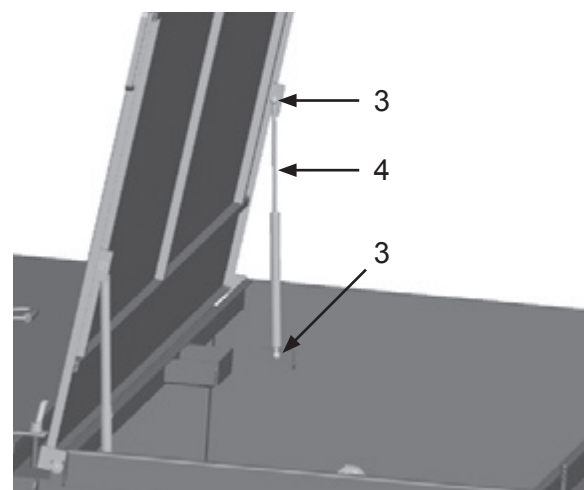

- 7) Move Hatch Door (5) to closed position.
- 8) Remove two Bolts (6).
- 9) Remove Hatch Door (5).

*Note: Approximate weight of Hatch Door is 86 pounds. Use suitable lifting devices to support or maneuver Hatch Door.*

- 10) Install parts in reverse order using the following special instructions:
  - Ensure Gas Spring installed on left side of hatch door is a "locking" style.

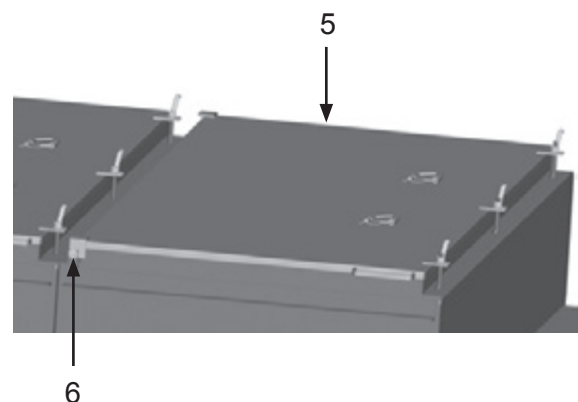

# MAINTENANCE

## Remove & Install Main Auger Protective Grate

### ⚠ WARNING

W-562

Always depressurize the entire system, disconnect all power sources and lockout/tagout all components before any maintenance or troubleshooting is attempted. Failure to comply with the above warning could cause electrical shock and inadvertent activation of equipment resulting in death or serious injury.

### ⚠ WARNING

W-588

Special precautions required before entering, Entry limited to trained personnel only. Compliance with all local, state, and federal regulations is required before entry. Failure to comply with the above warning could result in death or serious injury.

- 1) Turn off main power disconnect on main control box.
- 2) Close Ball Valve (1).
- 3) Remove twelve Bolts and Washers (2) and Access Panel (3).

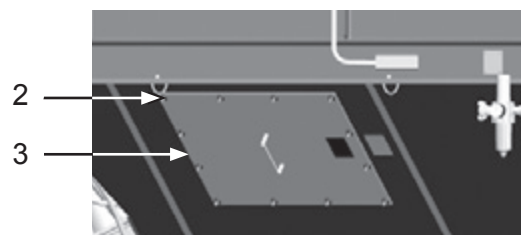
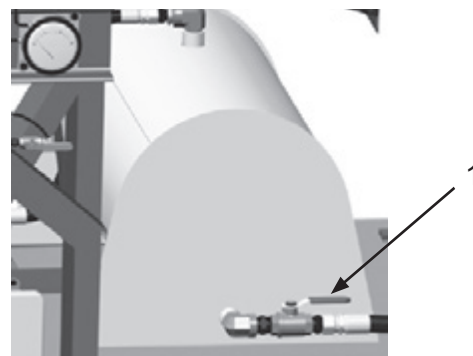

*Note: Side panels of hopper are not removed during this process. Side panels are not shown for clarity.*

- 4) Remove Nut (5), Washer (4), and Retainer (6). Repeat for remaining 11 Retainers.
- 5) Remove six Grates (7). Label and record position of Grates to aid installation.
- 6) Install parts in reverse order.

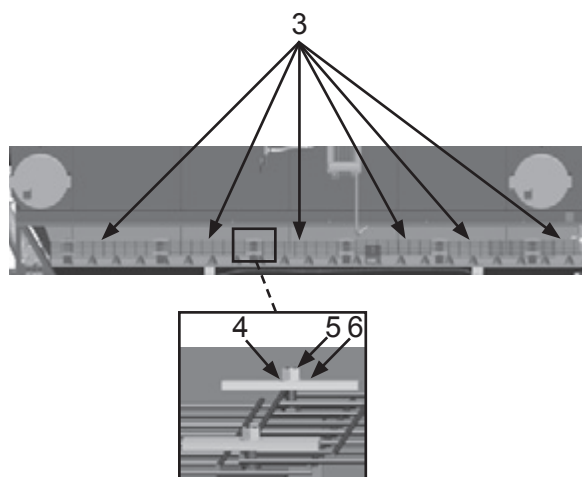

# MAINTENANCE

## Remove & Install Magnehelic Gauge

### **WARNING**

W-562

Always depressurize the entire system, disconnect all power sources and lockout/tagout all components before any maintenance or troubleshooting is attempted. Failure to comply with the above warning could cause electrical shock and inadvertent activation of equipment resulting in death or serious injury.

### **NOTICE**

N-530

Label all hoses and connections to aid installation.

- 1) Label Hose (2) as "Negative".
- 2) Label Hose (4) as "Positive".
- 3) Disconnect Hoses (2,4) from 90° Elbows (1,3).
- 4) Disconnect Hoses (2,4) from Magnehelic Gauge (5).

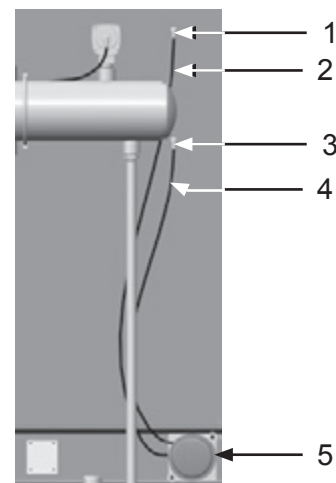

- 5) Remove Washers and Bolts (6).

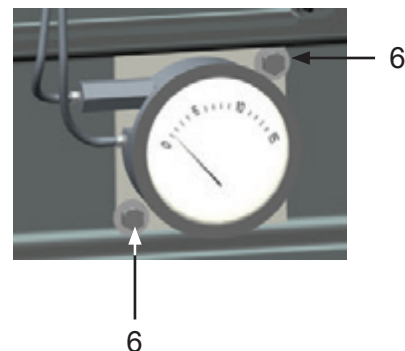

- 6) Install parts in reverse order using the following special instructions:
  - Ensure labeled hoses are installed correctly. "Negative" hose installed in lower port. "Positive" hose in upper port.

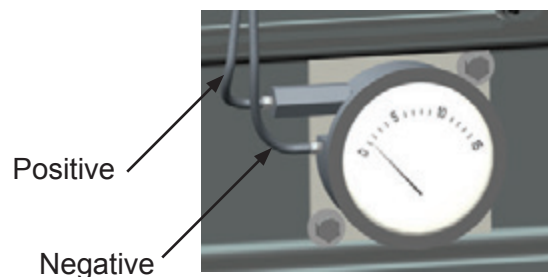

# MAINTENANCE

## Remove & Install Pneumatic Ball Vibrators

### ⚠ WARNING

W-562

Always depressurize the entire system, disconnect all power sources and lockout/tagout all components before any maintenance or troubleshooting is attempted. Failure to comply with the above warning could cause electrical shock and inadvertent activation of equipment resulting in death or serious injury.

### NOTICE

N-530

Label all hoses and connections to aid installation.

*Note: Front, right-hand side Pneumatic Ball Vibrator shown. Procedure is similar for all Pneumatic Ball Vibrators.*

- 1) Close Ball Valve (1)
- 2) Disconnect Hoses (2).
- 3) Remove two Hex Nuts and Flat Washers (3).
- 4) Repeat on opposite side of dust collector.
- 5) Install parts in reverse order.

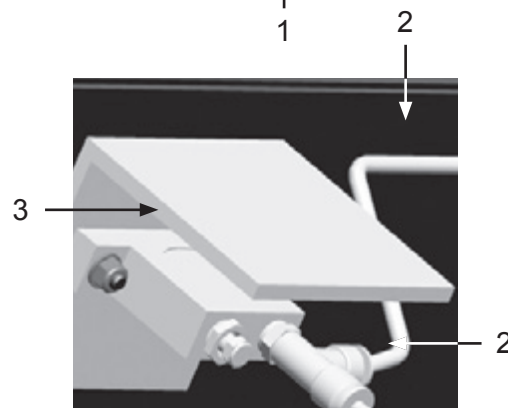
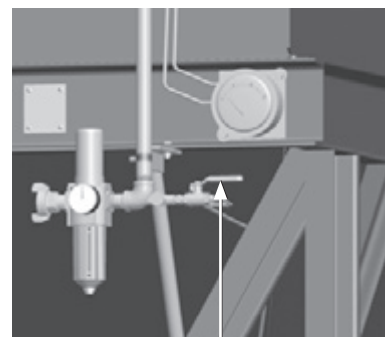

## Disassemble & Assemble Diaphragm Valve

- 1) Remove four Bolts (1) and Washers (2).
- 2) Remove Cover (3).
- 3) Remove Diaphragm (4).
- 4) Install parts in reverse order using the following special instructions:
  - Check Vent Hole (A) is not blocked or occluded.

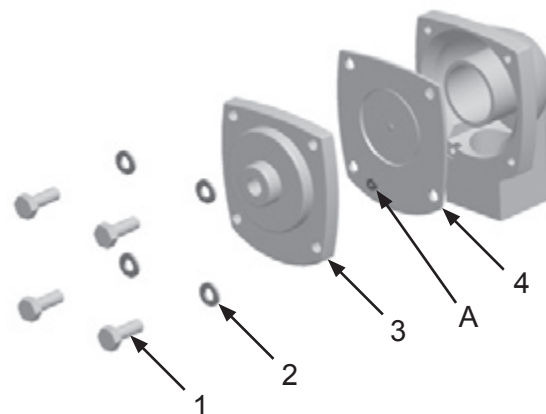



# TROUBLESHOOTING

If the Dustmaster® 50,000 CFM Electric Dust Collector does not function properly, check the following:

## **WARNING**

W-562

Always depressurize the entire system, disconnect all power sources and lockout/tagout all components before any maintenance or troubleshooting is attempted. Failure to comply with the above warning could cause electrical shock and inadvertent activation of equipment resulting in death or serious injury.

## **WARNING**

W-586

Moving parts can present an area where crushing, pinching, entanglement or amputation may occur. Do not place body parts or foreign objects in any area where there are moving parts. Failure to comply with the above warning could result in death or serious injury.

### **SYMPTOM (Cause)**

### **ACTION**

#### **Fan Drive Belt slips or vibrates**

*(Loose connections, worn parts)*

Inspect Fan Drive Belt for damage. Replace as needed.

Adjust Fan Drive Belt Tension. See Adjust Fan Drive Belt Tension.

See fan Operator's Manual for service.

#### **Discharge Augers do not turn**

*(Object in auger, hydraulic fluid levels, hydraulic pressure relief valve, hydraulic pump, hydraulic motor, stripped gear, broken chain)*

Run Discharge Auger in reverse to dislodge item. Dismantle Discharge Auger if object still lodged.

Fill hydraulic system with hydraulic fluid.

Check line pressure at by-pass gauge, reset or replace hydraulic valve.

Test hydraulic pump pressure. Replace hydraulic pump.

Bench test hydraulic motor. Repair or replace hydraulic motor.

#### **Magnehelic Gauge reading greater than normal operating range**

*(Dust Collector Filter Cartridges)*

A reading greater than 10" (w.c) on Magnehelic Gauge indicates clogged filters. Decrease engine RPM to idle speed and disengage clutch while allowing engine to run. Pulsers will clean down the filters. Once gauge reads back into the normal operation range of 3" – 10" (w.c), re-engage clutch and increase RPM to operating speed.

If Magnehelic Gauge is reading above 10" (w.c.), perform After Use procedure. Inspect Pulser System and Filters. Replace filter cartridges, if needed.

If Magnehelic Gauge is reading above 15" (w.c.), shut down unit immediately. Replace filter cartridges.

# TROUBLESHOOTING

## **WARNING**

W-562

Always depressurize the entire system, disconnect all power sources and lockout/tagout all components before any maintenance or troubleshooting is attempted. Failure to comply with the above warning could cause electrical shock and inadvertent activation of equipment resulting in death or serious injury.

## **WARNING**

W-586

Moving parts can present an area where crushing, pinching, entanglement or amputation may occur. Do not place body parts or foreign objects in any area where there are moving parts. Failure to comply with the above warning could result in death or serious injury.

## **SYMPTOM (Cause)**

### **Pulser System leaks**

*(Loose or missing hoses or connections, loose or missing urethane tubing, damaged diaphragm valves)*

## **ACTION**

Check hose and hose connections between diaphragm valves and hopper wall.

Check all tubing for secure connections and fittings. If fittings do not fit tightly in hose, cut a small section from the end of the hose and re-insert fitting in tube.

Inspect diaphragm valve for damage or debris. Repair or replace diaphragm valve.

### **Filter Pulser System pressurizes but does not pulse**

*(No power to control box, blown fuse in control box or timer board, disconnected wires, timer board, solenoid, diaphragm valve)*

Inspect all power connections. Repair or replace faulty connections.

Turn main power switch "ON", and look for indicator light. If indicator light does not signal, turn switch "OFF". Replace fuse.

Turn main power switch "OFF". Replace fuse.

Turn main power switch "ON", and look for indicator light. If indicator light does not signal, turn switch "OFF". Inspect all electrical connections.

Inspect all solenoids and listen for audible sound as it engages to pulse. Replace solenoid.

Inspect diaphragm valve breather vent for obstruction.

## **ADDITIONAL TECHNICAL DATA**

The associations listed below offer information, materials and videos pertaining to abrasive blasting and safe operating practices.

- **American Society for Testing and Materials (ASTM)**  
100 Barr Harbor Drive  
West Conshohocken, PA 19428-2959  
Phone: (610) 832-9585  
FAX: (610) 832-9555  
www.astm.org
- **Occupational Safety & Health Administration (OSHA)**  
United States  
Department of Labor  
200 Constitution Avenue  
Washington, DC 20210  
Phone: (800) 321-OSHA  
(800) 321-6742  
www.osha.gov
- **The National Board of Boiler & Pressure Vessel Inspectors**  
1055 Crupper Avenue  
Columbus, Ohio 4322  
Phone: (614) 888-8320  
FAX: (614) 888-0750  
www.nationalboard.org
- **National Association of Corrosion Engineers (NACE)**  
1440 South Creek Drive  
Houston, TX 77084-4906  
Phone: (281) 228-6200  
FAX: (281) 228-6300  
www.nace.org
- **The Society for Protective Coatings (SSPC)**  
40-24th Street, 6th Floor  
Pittsburgh, PA 15222-4656  
Phone: (412) 281-2331  
FAX: (412) 281-9992  
www.sspc.org
- **American National Standards Institute (ANSI)**  
1899 L Street, NW, 11th Floor  
Washington, DC 20036  
Phone: (202) 293-8020  
FAX: (202) 293-9287  
www.ansi.org

## **LIMITED WARRANTY**

Seller warrants to the original purchaser that the Product covered by this Limited Warranty will remain free from defects in workmanship or material under normal commercial use and service for a period of one year from the date of shipment to the original Purchaser. This Warranty shall not apply to defects arising, in whole or in part, from any accident, negligence, alteration, misuse or abuse of the Product, operation of the Product which is not in accordance with applicable instructions or manuals or under conditions more severe than, or otherwise exceeding, those set forth in the written specifications for the Product, nor shall this Warranty extend to repairs or alterations of the Product and/or any maintenance part by persons other than Seller or Seller's authorized representatives. This warranty does not apply to accessory items. Further, this Warranty does not apply to damage or wear to the surface finish or appearance of the Product or normal wear and tear to the Product. This Warranty is limited to a purchaser who purchases the Product either directly from the Seller or from one of Seller's "Authorized Distributors". An Authorized Distributor is a Seller approved distributor that purchases the Product directly from the Seller for the sole purpose of re-selling the Product at retail, without any use or modifications whatsoever, to an end-purchaser. This warranty is specifically non-assignable and non-transferable.

## **DISCLAIMER OF WARRANTY**

The foregoing Limited Warranty is exclusive and is in lieu of all other warranties, whether oral or written and whether express, implied, or statutory. SELLER HEREBY DISCLAIMS ALL OTHER WARRANTIES, INCLUDING BUT NOT LIMITED TO THE WARRANTIES OF MERCHANTABILITY AND/OR FITNESS FOR A PARTICULAR PURPOSE AND ALL SUCH OTHER WARRANTIES ARE HEREBY EXCLUDED AND ARE INAPPLICABLE TO THE PRODUCT. Seller makes no warranties or representations of any kind concerning respirators, or equipment made by other manufacturers. Seller's agents and representatives are not authorized to offer any further warranties.

## **EXCLUSIVE REMEDY FOR WARRANTY CLAIMS**

THE SOLE AND EXCLUSIVE REMEDY UNDER THE FOREGOING LIMITED WARRANTY, AND TO THE EXTENT PERMITTED BY LAW, ANY WARRANTY OR CONDITION IMPLIED BY LAW, COVERING THIS PRODUCT SHALL BE, AT THE SELLER'S OPTION, THE REPAIR OR REPLACEMENT, FREE OF CHARGE, F.O.B. POINT OF MANUFACTURE, OF ANY DEFECTIVE PART OR PARTS OF THE PRODUCT THAT WERE MANUFACTURED BY SELLER, AND WHICH ARE RETURNED TO SELLER AT SELLER'S PRINCIPAL PLACE OF BUSINESS, POSTAGE PREPAID BY THE PURCHASER. THIS SOLE AND EXCLUSIVE REMEDY IS CONDITIONED UPON PURCHASER'S PROMPT WRITTEN NOTICE TO SELLER AT SELLER'S PLACE OF BUSINESS THAT A DEFECT HAS BEEN DISCOVERED, TOGETHER WITH A REASONABLY DETAILED DESCRIPTION OF THE DEFECT IN THE PRODUCT, PROOF OF PURCHASE OF THE PRODUCT, AND THE MODEL AND IDENTIFICATION NUMBER OF THE PRODUCT WITHIN THIRTY (30) DAYS AFTER DISCOVERY OF THE DEFECT, OTHERWISE SUCH CLAIMS SHALL BE DEEMED WAIVED. NO ALLOWANCE WILL BE GRANTED FOR ANY REPAIRS OR ALTERATIONS MADE BY PURCHASER OR OTHERS WITHOUT SELLER'S PRIOR WRITTEN CONSENT. IF SUCH NOTICE IS TIMELY GIVEN, SELLER WILL HAVE THE OPTION TO EITHER MODIFY THE PRODUCT OR COMPONENT PART THEREOF TO CORRECT THE DEFECT, REPLACE THE PRODUCT OR PART WITH COMPLYING PRODUCTS OR PARTS, OR REFUND THE AMOUNT PAID FOR THE DEFECTIVE PRODUCT, ANY ONE OF WHICH WILL CONSTITUTE THE SOLE LIABILITY OF SELLER AND FULL SETTLEMENT OF ALL CLAIMS. IN NO EVENT SHALL SELLER BE LIABLE FOR ANY OBLIGATION GREATER THAN THE ORIGINAL PURCHASE PRICE OF THE PRODUCT UNDER THIS WARRANTY. PURCHASER SHALL AFFORD SELLER PROMPT AND REASONABLE OPPORTUNITY TO INSPECT THE PRODUCT FOR WHICH A CLAIM IS MADE. THE SOLE PURPOSE OF THE FOREGOING STIPULATED EXCLUSIVE REMEDY SHALL BE TO REPAIR OR REPLACE DEFECTIVE PRODUCTS OR COMPONENTS THEREOF, OR TO REFUND PURCHASER THE PURCHASE PRICE THEREOF. THIS STIPULATED EXCLUSIVE REMEDY SHALL NOT BE DEEMED TO HAVE FAILED OF ITS ESSENTIAL PURPOSE SO LONG AS SELLER IS WILLING AND ABLE TO REPAIR OR REPLACE THE DEFECTIVE PARTS OR REFUND THE PURCHASE PRICE IN ACCORDANCE WITH THE TERMS HEREOF. PRODUCTS THAT HAVE BEEN REPAIRED OR REPLACED UNDER THIS WARRANTY DO NOT RECEIVE A NEW WARRANTY AND ARE ONLY COVERED BY THE REMAINING PORTION OF THE ORIGINAL WARRANTY.

## **LIMITATION OF REMEDIES**

The foregoing stipulated exclusive remedy is in lieu of all other remedies for breach of contract, warranty, and/or tort or otherwise. Seller shall not be liable, either directly or indirectly, for any consequential, incidental or special losses or damages of Purchaser, including but not limited to the Purchaser's expenses for downtime or for making up downtime, damages for which the Purchaser may be liable to other persons and/or entities, damages to property, and injury to or death of any persons and/or any claims for incidental or consequential damages, including but not limited to loss of profits, regardless of whether Seller has been informed of the possibility of such damages. Seller neither assumes, nor authorizes any person to assume for it, any other liability in connection with the sale or use of any Products covered by the foregoing Warranty and Disclaimers, and there are no oral agreements relating to remedies which are collateral to or which affect this limitation.

## 40+ NATIONWIDE SHIPPING LOCATIONS

### GLOBAL HEADQUARTERS

- 3425 East Locust Street  
Davenport, IA 52803

ph: 800.BLAST.IT (800.252.7848)

ph: 563.324.2519

fax: 563.324.6258

### REGIONAL BRANCH OFFICES

- **Iowa**  
Davenport
- **Louisiana**  
Gonzales  
Harvey  
Lafayette
- **Ohio**  
Youngstown
- **Texas**  
Beaumont  
Corpus Christi  
Deer Park



★ Marco Regional Branch Offices  
and Shipping Locations

● Direct Shipping Locations



ABRASIVES

BLASTING

COATING

DUST COLLECTORS

ENGINEERED SYSTEMS

RENTAL

SAFETY

SERVICE & REPAIR

VACUUMS

### CONTACT MARCO

**800.BLAST.IT**

**(800.252.7848)**

**563.324.2519**

**FAX: 563.324.6258**

**WWW.MARCO.US**

**SALES@MARCO.US**