



DEVILBISS® MBC-510 AIR SPRAY GUN



PART NUMBERS AND SCHEMATIC GUIDE

Company Profile

Allredi was formed in the early 2020, when two of the largest distributors in the blasting, coating, safety, and environmental industry, APE Companies and Marco Group International, joined forces. While the qualities both companies are known for have not changed, a lot about our business is new. New abilities. New agilities. New ways to help you win. This calls for a new name, Allredi.

This name exemplifies what we have become. It is completely oriented to the needs of our customers. To your needs. It says that when you call us for anything – products, service, expert advice, anything – you can consider it done. Or even better, Allredi done.

We are your right-now supplier. From skills to SKUs, we deliver the goods fast. So you can be more agile every minute, every day. This is who we are. This is what our new name means. Go ahead and expect excellence, because we're bringing it.

Our Mission and Vision

To be the industry's preferred partner in surface preparation solutions through unrivaled technical expertise, customer experience, product availability, and tailored service offerings.

The Allredi Difference

- **Industry Experience** – With Allredi on your team, you have access to expertise which can only come from decades of industry leadership. We have organized our engineering department, production specialists, customer operations, and safety support into a "Center of Competence." As an Allredi customer, you have access to hundreds of years of cumulative experience related to your operations.
- **Manufacturing Excellence** – Allredi is a U.S. based manufacturer of equipment for the Surface Preparation and Protective Coatings industries. Allredi's engineers benchmark the industry to ensure that we design and manufacture superior products that set the "Gold Standard" for performance, safety, and quality.
- **Legendary Customer Service** – Allredi's legendary customer service team is staffed by friendly, highly-trained individuals who are focused on providing the highest level of product support, order accuracy, and customer satisfaction.
- **Product Availability** – We stock over 10,000 SKU's and have over 45 shipping locations to serve North American and International markets for all major brands of blasting, coating, environmental, and safety equipment. Allredi is your right-now supplier, so you can keep your projects moving. From our foundation of strong relationships, we have built a nationwide network that puts vast inventory and ready service close to our customers. We provide advanced expertise, and we deliver the goods fast – so you can easily access the products and services you need to me more agile every minute, every day.
- **Technology Leadership** – Our website provides: Operator's Manuals, Part Numbers and Schematics Guides, SDS information, and key product features and specifications, providing access to information 24/7.

TABLE OF CONTENTS

Company Profile	2
Table of Contents	3
DeVilbiss® MBC-510 Air Spray Gun	4-7
DeVilbiss® MBC-510 Air Spray Gun Part Numbers.....	4
Fluid Tips and Needles.....	5
Air Caps.....	5
Retaining Ring.....	5
Part Numbers and Schematics.....	6-7

PART NUMBERS AND SCHEMATICS GUIDE



Part Numbers

DEVILBISS® MBC-510 AIR SPRAY GUN					
Part Numbers	Fluid Tip	Fluid Tip Size	Air Cap	Pressure Feed	Suction Feed
20DMBC51064HDD	D	2.2 mm (0.086 in)	64HD	X	
20DMBC510D	D	2.2 mm (0.086 in)	None	X	
20DMBC51064HDE	E	1.8 mm (0.070 in)	64HD	X	
20DMBC510704E	E	1.8 mm (0.070 in)	704	X	
20DMBC510E	E	1.8 mm (0.070 in)	None	X	
20DMBC51030EX	EX	1.8 mm (0.070 in)	30		X
20DMBC510EX	EX	1.8 mm (0.070 in)	None		X
20DMBC510FF	FF	1.4 mm (0.055 in)	None	X	
20DMBC510FX	FX	1.1 mm (0.042 in)	None	X	

PART NUMBERS AND SCHEMATICS GUIDE



Part Number

FLUID TIPS AND NEEDLES			
Part Number	Orifice Size	Fluid Needle	Optional 303 S/S Tip Needle U.H.M.W. Poly
20DAV2115AC	2.8 mm (0.110 in)	20DMBC496C	
20DAV2115D	2.2 mm (0.086 in)	20DMBC496DEX	20DAV4915D
20DAV2115E	1.8 mm (0.070 in)	20DMBC444E	
20DAV2115EX	1.8 mm (0.070 in)	20DMBC496DEX	
20DAV2115FF	1.4 mm (0.055 in)	20DMBC444FF	20DAV4915FF
20DAV2115FX	1.1 mm (0.042 in)	20DMBC444FX	20DAV4912FX



Part Number

AIR CAPS		
Part Number	Cap Number	Retaining Ring Included
20DMB403930	30	X
20DAV43958	58	X
20DMB403962HD	62HD	X
20DMB403964HD	64HD	X
20DMB403969HD	69HD	X
20DMB403980	80	X
20DAV4024	24	
20DAV1239704	704	
20DAV1239765	765	
20D31767777	777	
20DAV1239797	797	
20DAV4409000	9000	

Part Numbers

DEVILBISS® MBC-510 RETAINING RING

Part Numbers	Description
 20DMBC368	DeVilbiss® MBC-510 Retaining Ring

PART NUMBERS AND SCHEMATICS GUIDE

DeVilbiss® MBC-510 Conventional Air Spray Gun

Item#	Part#	Description
Fig. 1		
1	—	Air Cap/Retaining Ring (<i>See Page 5</i>)
2	20DMBC368	Retaining Ring for Ref. No. 3 & 4
3	—	Air Cap Less Retaining Ring (<i>See Page 5</i>)
4	20DPMBC430D 20DPMBC430E 20DPMBC430EX 20DPMBC430FF 20DPMBC430FX	D Sprayhead Assembly E Sprayhead Assembly EX Sprayhead Assembly FF Sprayhead Assembly FX Sprayhead Assembly
5	—	Fluid Tip and Gasket Assembly (<i>See Page 5</i>)
6	20DAV1K5	Gasket Kit (<i>Kit of 5</i>)
7	20DMBC1225	Baffle
8	20DPMBC402	Sprayhead Body
9	20DA23K10	Packing Kit (<i>Kit of 10</i>)
10	20DMB19K5	Packing Nut Kit (<i>Kit of 5</i>)
11	—	Fluid Needle (<i>See Fluid Tips and Needles</i>)
14	20DJGS26K25	U-Cup Kit (<i>Kit of 25</i>)
15	20DJGS431K25	Air Valve Kit (<i>Kit of 25</i>)
16	20DMBD12K25	Spring Kit (<i>Kit of 25</i>)
17	20DJGS72K10	Gasket Kit (<i>Kit of 10</i>)
18	20DJGS4491	Valve Assembly
19	20DMBC1226K10	Gasket Kit (<i>Kit of 10</i>)
20	20DMBC67	Locking Bolt
21	20DMBC4981	Fan Adjustment Valve
27	20DMBC415	Cylinder Assembly
28	20DCV5K5	Gasket Kit (<i>Kit of 5</i>)
30	20DMBC33	Plunger
31	20DMBC29K5	Spring (<i>Kit of 5</i>)
32	20DMBC39	Screw
33	20DPMB51	Air Inlet Adapter 1/4" NPS
36	20DJGS478	Stud and Screw Kit (<i>3 studs, 5 screws in kit</i>)
37	20DJGS4771	Trigger, Stud and Screw Kit (<i>One Each</i>)
38	20DPMBC4283	Spray Gun Less Spray Head
39	—	Fluid Tip and Needle Assembly (<i>See Page 5</i>) (<i>not shown</i>)
—	20DKK40581	DeVilbiss® MBC-510 Conventional Spray Gun Repair Kit (<i>Includes Item #'s: 6, 9, 12, 13, 14, 15, 16, 17, 19, 23, 26, 28, 31, and 35</i>)
—	206M524	Part Numbers and Schematics Guide – DeVilbiss® MBC-510 Air Spray Gun
—	209V524	Operators Manual – DeVilbiss MBC-510 Air Spray Gun

PART NUMBERS AND SCHEMATICS GUIDE

Figure 1: DeVilbiss® MBC-510 Conventional Air Spray Gun

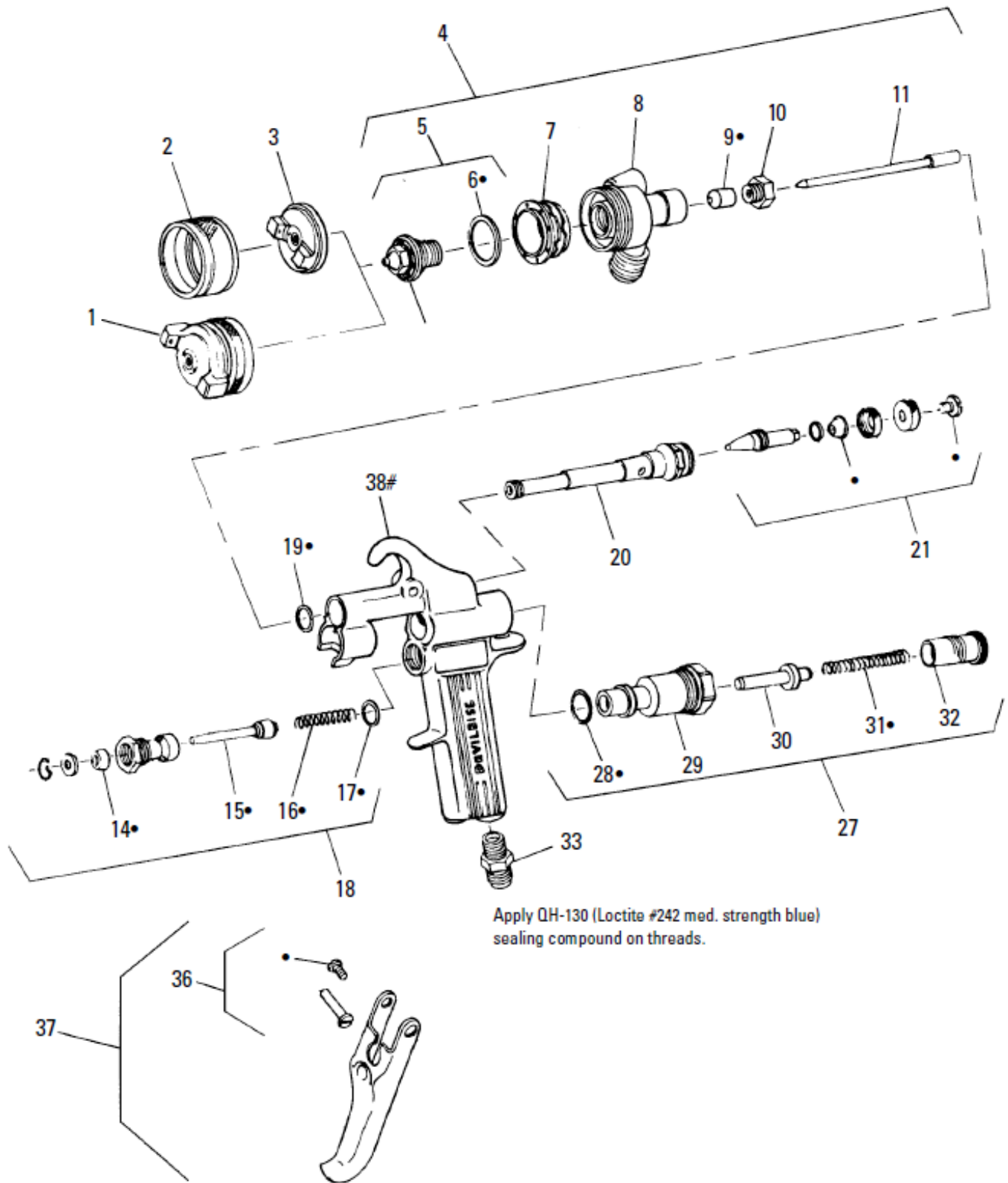



ALLREDI THERE

Serving these industries: Bridge, Pipeline, Tank & Tower, Concrete Services, Rail, Shipyard & Marine, Pools & Fountains and Foundry

UNITED STATES

Pasadena, TX (Headquarters)
844.361.7038

Beaumont, TX
409.722.1284

Bristol, PA
215.826.8080

Corpus Christi, TX
361.887.2038

Davenport, IA
563.324.2519

Deer Park, TX
(Service & Rental Location)
281.930.0905

Duluth, GA
800.535.4564

Gonzales, LA
225.647.7575

Harvey, LA
504.367.8090

Houma, LA
985.580.4273

Jacksonville, FL
904.262.2120

Lafayette, LA
337.267.1440

Theodore, AL
251.338.7525

Youngstown, OH
330.448.6267

CANADA

Calgary, Alberta
403.279.1924

Coquitlam, BC
604.464.6979

Edmonton, Alberta
780.468.2588 (Manus)
780.425.5510 (Mod-U-Blast)

Hamilton, Ontario
905.527.6000 / 888.794.5665

Mississauga, Ontario
905.890.5837

Winnipeg, Manitoba
204.256.3324

800-252-7848 / WWW.ALLREDI-US.COM

Allredi™ and Marco® are registered trademarks of Allredi, LLC.
All other brand names or marks are used for identification purposes and are trademarks of their respective owners.

ALLREDI™

Literature #206M524_8/24/22