



HVLP and Conventional Air Spray Guns and Accessories

Air atomizing spray guns for high-quality industrial finishing.

Spray Guns • Air Caps • Fluid Tips and Needles • Paint Cups • Accessories

DEVILBISS
The Right Way To Finish™



Maximum Performer

Classic Series

Conventional Series

Accessories

Table of Contents

Maximum Performer HVLP Series

Features & Benefits	3
HVLP Technology.....	4
JGHV™ Standard-Size	5
MSV™ Mid-Size.....	6
EGHV™ Touch-Up.....	7
TGHV™ Detail/Touch-Up	8
AGXV™ Automatic.....	9

Classic HVLP Series

HVLP Features & Benefits	10
HVLP Technology.....	11
JGA-HVLP Pressure Feed	12
JGA-HVLP Suction Feed	13
GFG-HVLP Gravity Feed.....	14
HVLP Fluid Tips, Needles & Air Cap Test Kits	15
HVLP Air Cap & Tip Selection Chart	16,17

Conventional Series

Features & Benefits	18
Selection Guide	19
JGA Standard-Size.....	20
MSA Mid-Size	21
MBC-510 Manual	22
EGA Touch-Up.....	23
GFG Gravity Feed.....	24
AGX Automatic	25
AGF Compact Auto / DGD-515 Duster Gun	26
Selecting the Air Cap, Fluid Tip & Needle	27
Air Cap Selection Guide.....	28
Fluid Tip & Needle Selection Guide	29

Accessories

Pressure, Suction & Gravity Feed Cups.....	30,31
Air Control	32
Cleaners, Strainers & Connectors.....	33
Other Equipment.....	34
System Solutions.....	35

When you want the best, ask for it by name.

Since Dr. Allen DeVilbiss first invented more than 100 years ago, the company has continually refined and improved



the spray atomizer that bears his name the process.

Today, DeVilbiss still leads the industry in the development of high transfer efficiency atomization processes and technology. DeVilbiss' product innovations range from our spray gun to the superior atomization of our Maximum Performer HVLP technology and include our specialty tools and accessories to support all of your spray finishing operations.



The net result: practical solutions and a systems approach to today's spray finishing challenges.

In practice, this means we're your partner. We listen. We observe. And we work hard to determine the best solution for you, regardless of the market or application. From appliances, aerospace and automotive, to electronics, metal and wood, the experts at DeVilbiss know your business. And that means improved quality, enhanced performance and reduced costs for our customers.



Add to that our staff of experienced engineers and designers, knowledgeable technicians and responsive customer service professionals, and you've got the best in the industry.



So ask for it by name. Ask for DeVilbiss.

DEVILBISS
The Right Way To Finish™

Maximum Performer Features and Benefits

Durability

- 1 300-grade stainless steel fluid passages offer waterborne compatibility, corrosion resistance and protection from harsh, self-etching primers.
 - Dual-seal fluid inlet assures a positive seal.
- 2 Drop forged aluminum gun bodies are strong, durable and lightweight.
- 3 Lightweight and precision-balanced for operator comfort.
 - Maximum Performer spray guns are sized to fit both the operator and the application, with standard-size, mid-size and detail/touch-up models.

- 4 Replaceable anodized aluminum baffle with air cap retaining ring threads eliminates the need to replace the gun body should threads become damaged.
- 5 Redesigned trigger strike pad makes trigger action smoother and extends air valve life.
 - Cartridge-type air valve is designed for positive sealing and quick triggering action.
 - All gun components have been life cycle tested to ensure reliability in production environments.

Performance

- 6 GoldMax™ air caps and special fluid tip, needle and baffle combinations provide unparalleled atomization.
 - Collectively, Maximum Performer spray guns can handle more than 90% of the materials and coatings being applied today, including higher solids materials and higher fluid flows.
- 7 Long-life needle packings require fewer adjustments.

Easy to Use

- 8 Light trigger action for easy operation and comfort.
- 9 Knurled knobs for easy adjustment of pattern and fluid flow.
- 10 1/4" air inlet connects to any standard compressor system.

Maintenance

- Simple, straightforward design for easy care and maintenance.
- Economical replacement parts are available and easy to install.

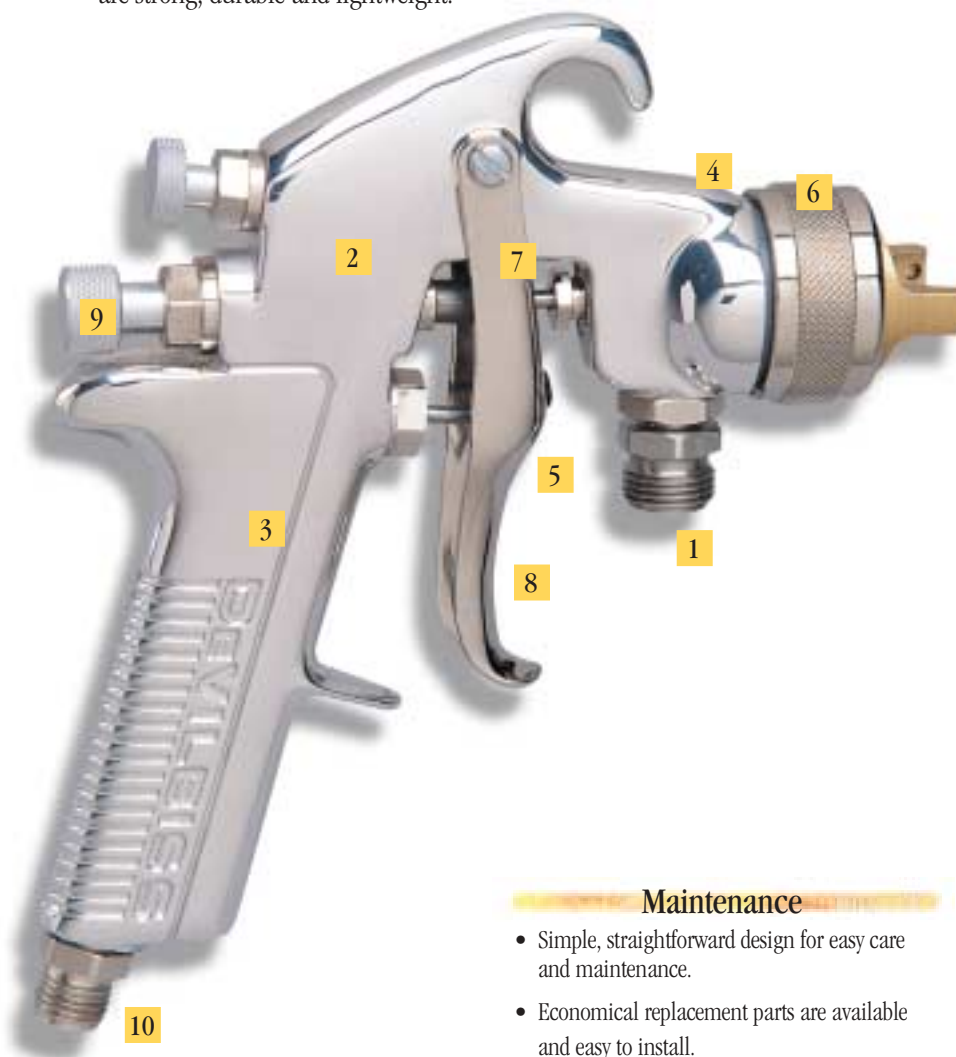

Maximum Performer HVLP Technology

The finest, most consistent atomization you can get.

The DeVilbiss Maximum Performer™ spray gun line provides HVLP finishing like you've never seen before.

And thanks to our exclusive GoldMax™ air caps, Maximum Performer spray guns deliver the finest, most consistent atomization, no matter what materials you spray - from low VOC enamels and polyurethanes to waterborne furniture and other topcoats.

The Maximum Performer HVLP gun family, designed to handle any application, includes:

- A standard-size manual spray gun designed to maintain the comfortable fit and feel operators prefer
- A lighter-weight mid-size model designed for reducing operator fatigue
- A gun designed for use with robots and automatic machines
- A comfortable and easy-to-control detail/touch-up spray gun

The DeVilbiss Maximum Performer line can collectively handle more than 90% of the coatings being applied today. In fact, your only alternative for similar performance is a costly electrostatic system.



MAXIMUM PERFORMER™

Reduce Operating Costs. Enhance Productivity.

High-volume low-pressure (HVLP) atomization uses a low-velocity air stream to deliver a more controlled spray pattern. As a result, there's improved transfer efficiency, less overspray and bounceback. That means a cleaner environment for the operator, with greater visibility and reduced operator error. It also means decreased paint consumption, which reduces spray booth maintenance, filter replacement, waste disposal and material costs.

The high transfer efficiency of HVLP also enhances productivity and finish quality. Because more paint is applied on each pass, fewer passes may be required by the operator.

DeVilbiss' Maximum Performer technology has greatly improved the HVLP process. Fitted with our unique GoldMax™ air caps and special fluid tip, needle and baffle combinations, Maximum Performer spray guns offer unparalleled atomization of a wide range of coatings, including higher solids materials and higher fluid flows.

Maximum Performer HVLP spray guns also meet the legislated VOC requirements of the California South Coast Air Quality Management District.

To help protect our environment, it is expected that similar legislation soon will be required throughout the nation.



High Pressure Spray (Conventional Air Spray)

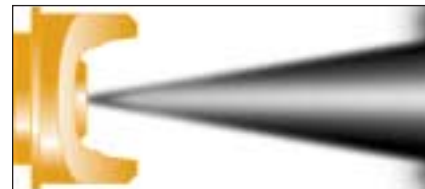

Low Pressure Spray (HVLP)

NOTE: DeVilbiss HVLP spray guns are protected by one or more of the following patents:

Patent # 5,209,405

Patent # 5,090,623

Patent # 5,344,078

JGHV™ Standard-Size Maximum Performer

Manual HVLP Spray Gun

Our JGHV Standard-Size Maximum Performer manual spray gun gives you the best of everything – the comfortable fit and feel of DeVilbiss' classic JGA spray gun combined with the high transfer efficiency and superior atomization of HVLP.

- 300-grade stainless steel fluid passages for waterborne compatibility.

Productivity and Finish Quality

The productivity and finish quality of any Maximum Performer spray gun is determined by the air cap and fluid tip combination. The chart on page 16 provides detailed information about the solids range, fluid flow and air consumption for specific caps and tips. It also illustrates the spray pattern for each air cap.



The versatile JGHV gun delivers a high quality finish with less overspray than conventional guns.



For gun, cap and tip information see charts on pages 15 & 16.

Ordering Information

The JGHV Standard-Size Maximum Performer manual spray gun is available with the following air cap and fluid tip set-ups, factory assembled for immediate delivery.

Part No.	
JGHV-531-33EX*	JGHV-531-83E*
JGHV-531-33FF*	JGHV-531-83D*
JGHV-531-46FX*	
JGHV-531-46FF*	

** Standard tips and needles are 400-grade stainless steel. See page 15 for fluid tips and needles.*

Technical Specifications

Body:	Drop forged aluminum
Weight:	20.8 oz (599 gr)
Air Inlet:	1/4" NPS (M)
Fluid Inlet:	3/8" NPS (M)
Fluid Passages:	Stainless steel
Feed Type:	Pressure Feed
Service Bulletin:	SB-2-246
Gun Repair Kit:	KK-4987-2

Accessories

- **Remote Cups**
Two-quart remote cups are available in aluminum (KB-555) or stainless steel (KB-545-SS).
- **Attached Cups**
One-quart attached cups are available in aluminum with Teflon® lining (TLC-576) or stainless steel (TSC-591).
Note: KK-4980 regulator control kit is required for use with these cups and must be ordered separately.
- **Additional Accessories**
Hose assemblies, air control regulators, air cap test kits, gun and hose cleaning equipment and other accessories also are available.

MSV™ Mid-Size Maximum Performer

Manual HVLP Spray Gun

Our MSV Mid-Size Maximum Performer spray gun delivers the same high transfer efficiency and superior performance as the standard-sized model, only in a smaller package. Weighing only 17 ounces, the Mid-Size Maximum Performer spray gun is lighter, and it helps reduce operator fatigue while providing excellent comfort and control.

- 300-grade stainless steel fluid passages for waterborne compatibility.

For gun, cap and tip information see charts on pages 15 & 16.

Productivity and Finish Quality

The productivity and finish quality of any Maximum Performer spray gun is determined by the air cap and fluid tip combination. The chart on page 16 provides detailed information about the solids range, fluid flow and air consumption for specific caps and tips. It also illustrates the spray pattern for each air cap.



The lightweight MSV spray gun is designed for maximum operator comfort.

Technical Specifications

Body:	Drop forged aluminum
Weight:	17 oz (476 gr)
Air Inlet:	1/4" NPS (M)
Fluid Inlet:	3/8" NPS (M)
Fluid Passages:	Stainless steel
Feed Type:	Pressure feed
Service Bulletin:	SB-2-243
Gun Repair Kit:	KK-4987-2

Ordering Information

The MSV Mid-Size Maximum Performer manual spray gun is available with the following air cap and fluid tip set-ups, factory assembled for immediate delivery.

Part No.	
MSV-531-33EX*	MSV-531-3-46FX**
MSV-531-33FF*	MSV-531-3-46FF**
MSV-531-46FF*	MSV-531-83E*
MSV-531-46FX*	MSV-531-83D*

* Standard tips and needles are 400-grade stainless steel.

** Includes 300-grade stainless steel with U.H.M.W. polyethylene seat in fluid tip. See page 15 for fluid tips and needles.



Accessories

- **Remote Cups**
Two-quart remote cups are available in aluminum (KB-555) or stainless steel (KB-545-SS).
- **Attached Cups**
One-quart attached cups are available in aluminum with Teflon® lining (TLC-576) or stainless steel (TSC-591).
Note: KK-4980 regulator control kit is required for use with these cups and must be ordered separately.
- **Additional Accessories**
Hose assemblies, air control regulators, air cap test kits, gun and hose cleaning equipment and other accessories also are available.

EGHV™ Touch-Up Maximum Performer

HVLP Spray Gun



For gun, cap and tip information see charts on pages 15 & 17.

Comfortable and easy-to-use, the EGHV Touch-Up Maximum Performer spray gun provides precise control for the most exacting detail and touch-up work. The gun features a long tapered fluid needle and a top-mounted trigger, and weighs only 7.5 ounces, making it ideal for hours of fatigue-free precision painting.

- Fluid delivery by attached suction feed or remote pressure feed cup.
- Knurled knobs for fine adjustments of fluid flow and spray pattern.

Productivity and Finish Quality

The productivity and finish quality of any Maximum Performer spray gun is determined by the air cap and fluid tip combination. The chart on page 17 provides detailed information about the solids range, fluid flow and air consumption, and also illustrates the spray pattern.

Ordering Information

The EGHV Touch-Up Maximum Performer manual spray gun is available with the following air cap and fluid tip set-up, factory assembled for immediate delivery.

Part No.

EGHV-531-397E *

* Standard tip and needle is 400-grade stainless steel.

EGHV Accessories

- **8 oz. Cup (TGS-503)**
Solvent-resistant polyethylene cup available.
- **Remote Cups**
Two-quart remote cups are available in aluminum (KB-555) or stainless steel (KB-545-SS).
- **Additional Accessories**
Hose assemblies, air cap test kit, gun and hose cleaning equipment and other accessories also are available.

Technical Specifications

Body:	Drop forged aluminum
Weight:	7.5 oz (210 gr)
Air Inlet:	1/4" NPS (M)
Fluid Inlet:	1/4" NPS (M)
Fluid Passages:	Stainless Steel
Feed Type:	Pressure feed Suction feed
Air Consumption:	8.8 CFM max. @ 10 psi cap pressure
Air Cap Pressure:	10 psi @ 50 psi inlet
Service Bulletin:	SB-2-167
Gun Repair Kit:	KK-5044



EGHV-531 gun and TGS-503 translucent polyethylene cup provide a precision finish with less overspray.

TGHV™ Detail/Touch-Up Maximum Performer

Manual HVLP Spray Gun

Our versatile, TGHV Detail/Touch-Up Maximum Performer spray gun offers superior atomization at the tip, combined with the comfort benefits of a lightweight, pistol-grip design, side port fluid inlet for gravity, and standard bottom inlet for pressure/suction feed.

Requiring low air cap pressure, our TGHV spray gun provides the control needed for detail, repair, shading and highlighting operations. Depending on the type of feed used, an adjustable spray pattern from 5" to less than 1/4" round makes the TGHV ideal for applications requiring focused spray patterns, such as automotive OEM spot repair, final repair, as well as mask spraying in furniture manufacturing, plastic decorating, and other applications requiring small defined patterns or mask spraying.

For gun, cap and tip information see charts on pages 15 & 17.

- Side port gravity feed with smaller front end for better operator visibility to the spray target.



TGHV-635 Gravity Feed with 8 oz. stainless steel cup

- 300-grade stainless steel fluid passages for waterborne compatibility.
- Includes built-in air adjusting valve for precise operator control.
- All TGHV series guns utilize many of the same high quality components as DeVilbiss JGA, MSA, and MSV spray guns.



Productivity and Finish Quality

The productivity and finish quality of any Maximum Performer spray gun is determined by the air cap and fluid tip combination. The chart on page 17 provides detailed information about the solids range, fluid flow and air consumption, and also illustrates the spray pattern.

Ordering Information

The TGHV Detail/Touch-Up Maximum Performer manual spray gun is available in the following models, factory assembled for immediate delivery.

Part No.
TGHV-530-Pressure/Suction Feed**
TGHV-635-Gravity Feed*

* Standard tip and needle is 300-grade stainless steel (F) .041".

** Standard tip is 300-grade s.s., (F) .041", and needle is acetel.

TGHV Accessories

- **Remote Cups**
Two-quart remote cup is available in aluminum (KB-555) or stainless steel (KB-545-SS).
- **Additional Accessories**
Hose assemblies, air cap test kit, gun and hose cleaning equipment and other accessories are also available.

Technical Specifications

Body:	Drop forged aluminum
Weight:	19 oz. (530g) TGHV-530 24.5 oz. (690g) TGHV-635 with 8 oz. cup
Air Inlet:	1/4" NPS(M)
Fluid Inlet:	3/8" NPS(M) - TGHV-530 1/4" BSP(M) - TGHV-635
Fluid Passages:	300-grade stainless steel
Air Consumption:	6.7 SCFM @ 10 psi air cap
Air Requirements:	35 psi inlet = 10 psi cap pressure
Service Bulletin:	SB-2-192
Gun Repair Kit:	KK-5048

AGXV™ Automatic Maximum Performer

HVLP Spray Gun



Designed for use with robots, automatic machines and stationary mounting, the AGXV Automatic Maximum Performer spray gun is built to withstand the harsh conditions common to automatic spray finishing applications.

- Only two moving parts, for greater reliability and easier maintenance.



- Patented Teflon® needle packings are spring loaded for extended service.
- Abrasive fluid packing available as an option for more abrasive coatings.
- Detachable spray head for fast needle packing replacement.
- Circulating capability standard.
- Optional remote fan control.

Productivity and Finish Quality

The productivity and finish quality of any Maximum Performer spray gun is determined by the air cap and fluid tip combination. The chart on page 16 provides detailed information about the solids range, fluid flow and air consumption for specific caps and tips. It also illustrates the spray pattern for each air cap.

For gun, cap and tip information see charts on pages 15 & 16.

Ordering Information

The AGXV Automatic Maximum Performer manual spray gun is available with the following air cap and fluid tip set-ups, factory assembled for immediate delivery.

Part No.	
AGXV-540-33AFF*	AGXV-541-83D*
AGXV-540-33AFX*	AGXV-541-83E*
AGXV-541-46FF**	AGXV-543-46FF**
AGXV-541-46FX*	AGXV-543-46FX**

* Standard tips and needles are 400-grade stainless steel.

** Includes 300-grade stainless steel with U.H.M.W. polyethylene seat in fluid tip. See page 15 for fluid tips and needles.

Technical Specifications

Body:	Machined aluminum
Weight:	26 oz (728 gr) without mounting stud 30 oz (840 gr) with mounting stud
Cylinder Air Pressure:	50 psi min. 100 psi max.
Cylinder Air:	1/4" NPS (M)
Atomization Air:	1/4" NPS (M)
Fluid Inlet:	3/8" NPS (M)
Fluid Passages:	300 Grade stainless steel
Fluid Pressure:	100 psi max.
Mounting Stud:	3/4" dia.
Service Bulletin:	SB-2-628
Gun Repair Kit:	KK-4992-1

Accessories

- **Remote Fan Control (KK-4955)**
Permits remote adjustment of pattern size.
- **Fluid Tip and Needle Sets**
Several kits are available for corrosive materials, primers and highly pigmented materials.
- **Mounting Clamp (AGA-415)**
Clamps gun stud to rod, allowing gun rotation to any angle.
- **Abrasive Fluid Seal Kit (KK-5017)**
Designed for use with abrasive materials.
- **Mounting Block Accessory Kit (KK-5046)**
Allows mounting the gun onto a 1/2" rod.
- **Additional Accessories**
Fluid regulators, fluid strainers, air control units, gun and hose cleaning equipment and other accessories also are available.



The AGXV automatic HVLP spray gun is ideal for spraying both waterborne and solvent-based coatings at high production speeds.

Classic Series HVLP Features and Benefits

Durability

- 1 300-grade stainless steel fluid passages offer waterborne compatibility, corrosion resistance and protection from harsh, self-etching primers.
 - Dual-seal fluid inlet assures a positive seal.
- 2 Drop forged aluminum gun bodies are strong, durable and lightweight.

- 3 Replaceable baffle with anodized aluminum air cap retaining ring threads eliminates the need to replace the gun body, should threads become damaged.

- 4 Redesigned trigger strike pad makes trigger action smoother and extends air valve life.
 - Cartridge-type air valve is designed for positive sealing and quick trigger action.
 - All gun components have been life cycle tested to ensure reliability in production environments.

Performance

- 5 Lightweight and precision-balanced for operator comfort.
 - Classic Series spray guns are sized to fit both the operator and the application, in standard-size and mid-size models.
- 6 Long-life needle packings.

Easy to Use

- 7 Light trigger action for easy operation and comfort.
- 8 Knurled knobs for easy adjustment of pattern and fluid flow.
- 9 1/4" air inlet connects to any standard compressor system.

Maintenance

- Simple, straightforward design for easy care and maintenance.
- Economical replacement parts are the same as those for the popular JGA gun.

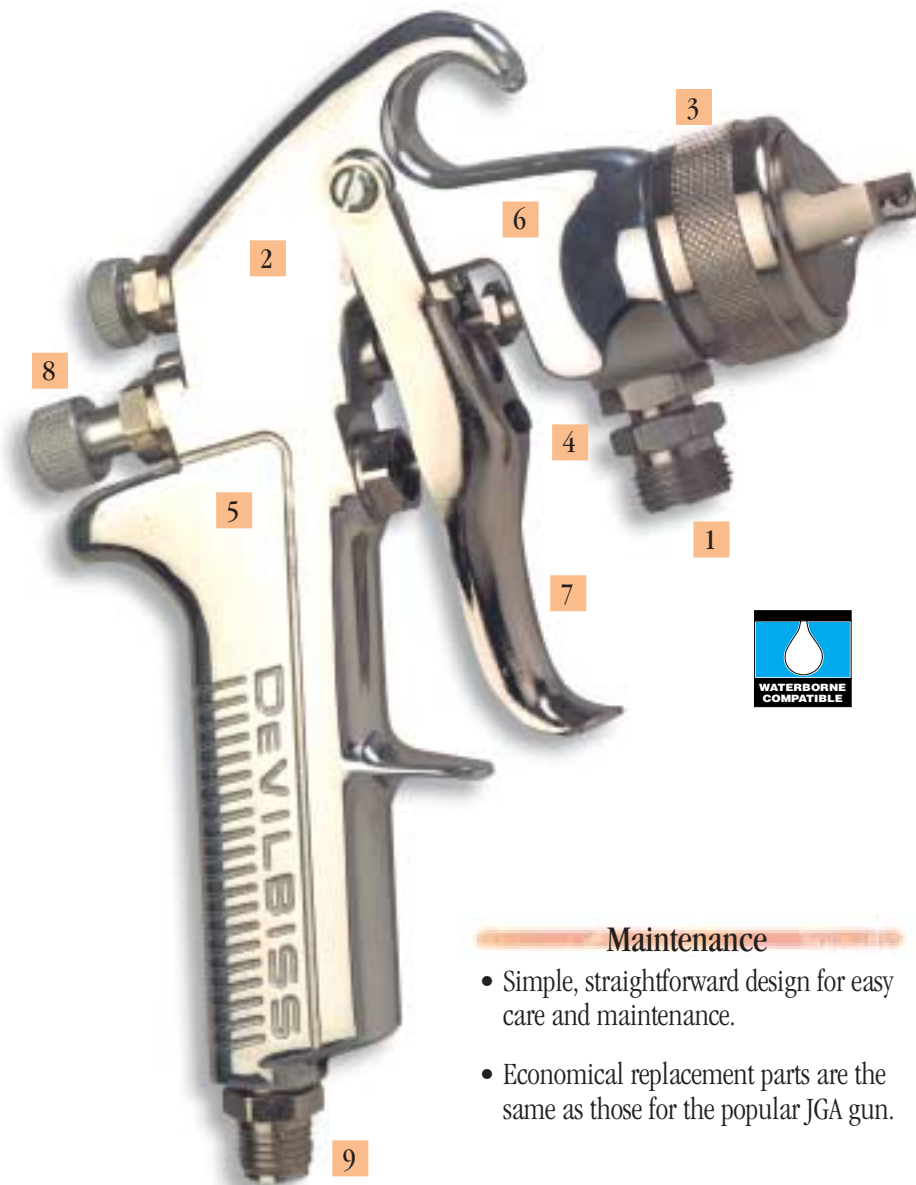

Classic Series HVLP Technology

Increase productivity and quality as you cut operating costs.

High-volume low-pressure (HVLP) atomization uses a low-velocity air stream to deliver a more controlled spray pattern.

The result? Improved transfer efficiency, less overspray and reduced bounceback – and that means a cleaner environment for the operator, with greater visibility and reduced operator error. It also means decreased paint consumption, which reduces spray booth maintenance, filter replacement, waste disposal and materials costs.

The high transfer efficiency of HVLP also enhances productivity and finish quality – because more material is applied on each pass, fewer passes are required by the operator.

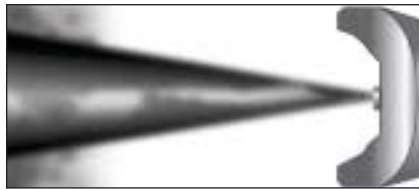

High Pressure Spray (Conventional Air Spray)

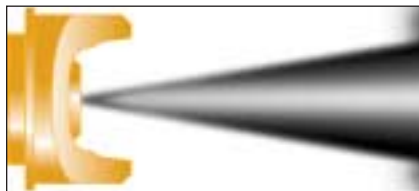

Low Pressure Spray (HVLP)

NOTE: DeVilbiss HVLP spray guns are protected by one or more of the following patents:

Patent # 5,209,405

Patent # 5,090,623

Patent # 5,344,078



Classic Series HVLP Spray Guns

The DeVilbiss line of Classic Series spray guns provides HVLP performance in four widely used gun models:

- *A pressure feed spray gun designed to maintain the comfortable fit and feel operators prefer.*
- *A model that combines the advantages of gravity feed fluid flow with the quality and performance of HVLP.*
- *An all-purpose suction feed HVLP spray gun.*

Ideal for low to medium flow rates, Classic Series HVLP spray guns are designed to handle most common lower solids coatings, such as stains, sealers, primers, enamels, and lacquers.

ITW DeVilbiss

HVLP That Works™

JGA-HVLP Pressure Feed Classic Series Spray Gun

For quality results and continuous output production, our JGA-HVLP spray gun is hard to beat. It delivers smooth triggering action and a comfortable fit and feel, so operators enjoy better control and less fatigue. And it also provides good atomization and high transfer efficiency, and is ideal for applications with limited air supply.

For gun, cap and tip information see charts on pages 15 & 17.

- 300-grade stainless steel fluid passages offer waterborne compatibility, corrosion resistance and protection from harsh self-etching primers.

Productivity and Finish Quality

The productivity and finish quality of any Classic Series spray gun is determined by the air cap and fluid tip combination. The chart on page 17 provides detailed information about the solids range, fluid flow and air consumption, and also illustrates the spray pattern for the 98 air cap.



The versatile JGA-HVLP gun delivers a high quality finish with less overspray than conventional guns.

Ordering Information

The Classic Series JGA-HVLP standard-size spray gun is available with the following air cap and fluid tip set-up, factory-assembled for immediate delivery.

Part No.

JGA-510-98FX*

** Standard tip and needle is 400-grade stainless steel. 300-grade tip and needle is optional for materials with pH less than 7.*

Technical Specifications

Body:	Drop forged aluminum
Weight:	20.4 oz (578 gr)
Air Inlet:	1/4" NPS (M)
Fluid Inlet:	3/8" NPS (M)
Fluid Passages:	300 grade stainless steel
Feed Type:	Pressure feed
Service Bulletin:	SB-2-187
Gun Repair Kit:	KK-4987-2

JGA-HVLP Application Guide

- Maximum 8 oz./min. fluid flow.
- Lower solids coatings.
- Medium to high V.O.C. coatings (4.0-5.0 lbs./gal.)
- Smaller compressors – 3 h.p. is usually sufficient.
- Limited air supply - requires only 11 CFM at 10 PSI air cap pressure.
- Class "B" finish quality requirements.



Accessories

- Two-quart remote cups are available in aluminum (KB-555) or stainless steel (KB-545-SS).
 - One-quart attached cups are available in aluminum with Teflon® lining (TLC-576) or stainless steel (TSC-591).
- Note:* KK-4980 regulator control kit is required for use with these cups and must be ordered separately.
- Hose assemblies, air control regulators, gun and hose cleaning equipment and other accessories also are available.
 - 303-grade lapped tip and needle set JGA-4056-FX.
 - For air cap test kit, see page 15.

JGA-HVLP Suction Feed Classic Series Spray Gun



The JGA-HVLP suction feed spray gun offers easy-to-use suction feed operation with the high transfer efficiency of HVLP. That means you get the flow rates and uniform spray patterns you want using conventional suction feed fluid delivery.

- 300-grade stainless steel fluid passages offer waterborne compatibility, corrosion resistance and protection from harsh self-etching primers.

Productivity and Finish Quality

The productivity and finish quality of any Classic Series spray gun is determined by the air cap and fluid tip combination. The chart on page 17 provides detailed information about the solids range, fluid flow and air consumption, and also illustrates the spray pattern for the #57 air cap.

Ordering Information

The Classic Series JGA-HVLP suction feed spray gun is available with the following air cap and fluid tip setups, factory-assembled for immediate delivery. Standard tip and needle are 400-grade stainless steel.

Part No.

JGA-510-57D*

JGA-510-57DE*

* Cup not included. Order separately.

When ordering DeVilbiss spray guns, the part number includes information on the specific gun model, air cap and fluid tip you will receive.

Example: JGA-510-



Technical Specifications

Body:	Drop forged aluminum
Weight (Less Cup):	21.4 oz (608 gr)
Air Inlet:	1/4" NPS (M)
Fluid Inlet:	3/8" NPS (M)
Fluid Passages:	300 grade stainless steel
Feed Type:	Suction feed
Service Bulletin:	SB-2-248
Gun Repair Kit:	KK-4987-2

For gun, cap and tip information see charts on pages 15 & 17.

Accessories

- One-quart paint cups available in Teflon[®]-lined aluminum (TLC-555), aluminum (TGC-545) and stainless steel (TSC-595).
- One-pint aluminum cup (TGC-536) is also available.
- Hose assemblies, air control regulators, gun and hose cleaning equipment and other accessories also are available.
- For air cap test kit, see page 15.



JGA-HVLP suction feed provides high quality atomization with the high transfer efficiency of HVLP.

GFG-HVLP Gravity Feed Classic Series Spray Gun



For gun, cap and tip information see charts on pages 15 & 17.

- 300-grade stainless steel fluid passages offer waterborne compatibility, corrosion resistance and protection from harsh self-etching primers.
- Standard equipment includes 32 oz. aluminum cup and booth-mount gun hook.
- Drip check in the cup lid prevents leaks and spills from the vent hole.
- Includes EZ liner® disposable cup liners to speed up cleaning, and allows upside-down spraying.

Productivity and Finish Quality

The productivity and finish quality of any Classic Series spray gun is determined by the air cap and fluid tip combination. The chart on page 17 provides detailed information about the solids range, fluid flow and air consumption, and also illustrates the spray pattern for the #57 air cap.

Ordering Information

Classic Series GFG-HVLP gravity feed spray guns are available with the following air cap and fluid tip set-ups, factory-assembled for immediate delivery. A new 32 oz. aluminum gravity cup is included. Standard tip and needle are 400-grade stainless steel.

Part No.

GFG-618-57DFE
GFG-618-57DFW
GFG-618-57DE

When ordering DeVilbiss spray guns, the part number includes information on the specific gun model, air cap and fluid tip you will receive.

Example: GFG-618-

Basic Gun Model (including cup)	Air Cap Number	Fluid Tip Size

Technical Specifications

Body:	Drop forged aluminum
Weight (Gun & Cup):	27 oz (768 gr)
Air Inlet:	1/4" NPS (M)
Fluid Inlet:	3/8" BSP (F)
Fluid Passages:	300 grade stainless steel
Feed Type:	Gravity feed
Service Bulletin:	SB-2-169
Gun Repair Kit:	KK-5025

Accessories

- 20 oz. Delrin cup (GFC-501).
- Workbench gun holder (GH-505) holds the gun upright to facilitate filling.
- Hose assemblies, air control regulators, gun and hose cleaning equipment and other accessories also are available.
- For air cap test kit, see page 15.



For smaller production jobs, GFG-HVLP provides the quality and performance of HVLP technology with the advantages of gravity fluid flow.

HVLP Air Cap Test Kits*



* Air cap test kits may be required by some air quality agencies. These kits are supplied with a special air cap and test gauge to demonstrate actual pressure being used at the cap since it will vary depending on hose length between the air regulator and gun.

This kit can be used as a quality control device for consistent spraying each day. The cap kit should not be used when finishes are being applied.

- **KK-5033-33A** Air Cap Test Kit – Includes air cap and gauge, for use with #33A air caps only.
- **KK-5033-46MP** Air Cap Test Kit – Includes air cap and gauge, for use with #46MP air caps only.
- **KK-5033-83MP** Air Cap Test Kit – Includes air cap and gauge, for use with #83MP air caps only.
- **KK-5033-90HV** Air Cap Test Kit – Includes air cap, gauge and ring, for use with #90HV air caps only.
- **KK-5043** Air Cap Test Kit – Includes air cap and gauge, for use with #397HV air caps only.

- **OMX-5033-46MP** – Includes air cap, gauge and ring, for use with OMX-411-46MP
- **OMX-5033-83MP** – Includes air cap, gauge and ring, for use with OMX-411-83MP

- **KK-5033-98** Air Cap Test Kit – Includes air cap and gauge, for use with JGA-HVLP spray gun using #98 air cap.
- **KK-5033-57** Air Cap Test Kit – Includes air cap and gauge, for use with GFG-HVLP gravity feed and JGA-HVLP suction feed spray guns using #57 air caps.

HVLP Fluid Tips and Needles

Maximum Performer

NUMBER ON FLUID TIP	ORDER TIP AND NEEDLE SET
<i>For JGHV and MSV</i>	
AV-2115-FE, FX	JGA-4040-FE, FX ⁽¹⁾
AV-2120-D, E, FE, FX	JGA-4045-D, E, FE, FX ⁽¹⁾
AV-4915-D, E, FE, FX, G	JGA-4056-D, E, FE, FX, G ⁽²⁾
AV-4920-D, E, FE, FX	JGA-4051-D, E, FE, FX ⁽²⁾
<i>For AGXV</i>	
AV-2115-FE, FX	AGX-4402-FE, FX ⁽¹⁾
AV-2120-D, E	AGX-4483-D,E ⁽¹⁾
AV-2120-FE, FX	AGX-4600-FE, FX ⁽¹⁾
AV-4915-E, FE, FX	AGX-4300-E, FE, FX ⁽²⁾
AV-4920-D, E, FE, FX	AGX-4613-D, E, FE, FX ⁽²⁾
<i>For MAX</i>	
FFP	OMX-4033 ⁽⁴⁾
FXP	OMX-4034 ⁽⁴⁾
EP	OMX-4035 ⁽⁴⁾
<i>For EGHV</i>	
EGA-60-E,F	EGA-4000-E, F ⁽¹⁾
<i>For TGHV</i>	
CV-30-F-HV	TGHV-4000-F ⁽⁵⁾ TGHV-4001-F ⁽⁵⁾

Classic Series

NUMBER ON FLUID TIP	ORDER TIP AND NEEDLE SET
<i>For JGA-HVLP (Pressure)</i>	
AV-2115-FX	JGA-4040-FX ⁽¹⁾
AV-1915-FX	JGA-4056-FX ⁽²⁾
<i>For GFG-HVLP</i>	
AV-2125-DFF	JGA-4046-14 ⁽⁶⁾
AV-2125-DFW	JGA-4046-16 ⁽⁶⁾
AV-2125-DE	JGA-4046-18 ⁽⁶⁾
<i>For JGA-HVLP (Suction)</i>	
AV-2125-DE	JGA-4046-18 ⁽⁶⁾
AV-2125-D	JGA-4046-22 ⁽⁶⁾

- (1) 400-grade stainless steel (lapped).
- (2) 300-grade stainless steel with U.H.M.W. polyethylene seat in fluid tip (matched set).
- (3) Acetal and 300 stainless tip.
- (4) Composite spraybead, 400-grade stainless steel needle with U.H.M.W. polyethylene tip.
- (5) 300-grade stainless steel (lapped).
- (6) 400-grade stainless steel (matched set).

HVLP Air Cap & Tip Selection Chart

JGHV, MSV, AGXV and MAX

TYPICAL COATINGS USED WITH	TYPICAL SOLIDS BY VOLUME VISCOSITIES*	AIR CAP MODEL NO. PART NO.	AIR VOLUME (AT 10 psi AIR CAP PRESSURE)	TYPICAL FLUID FLOW RATES	PATTERN SIZE**	RECOMMENDED FLUID TIPS
Low solids automotive finishes, enamels, lacquers, stains, sealers, etc.	Low solids up to 25% solids by volume Up to 24 seconds, #4 Ford cup	#33A JGHV-101-33A	18.75 CFM	Up To 12 oz./min.	9"	FF (.055") or FX (.042")
Medium solids enamels, urethanes, solvent and waterborne furniture top-coats, waterborne automotive OEM finishes, corrosion protective coatings, leather stains, acrylics, epoxies, etc.	Low-medium solids, up to 50% solids by volume Up to 28 seconds, #4 Ford cup	#46 MP JGHV-101-46MP	22.5 CFM	12-16 oz./min	11"	FF (.055") or FX (.042")
Medium-high solids enamels, urethanes, low VOC waterborne furniture top-coats, porcelain enamel, corrosion protective coatings, acrylics, epoxies, etc., architectural and industrial maintenance coatings.	Medium-high solids, up to 72% solids by volume Over 28 seconds, #4 Ford cup	#83 MP JGHV-101-83 MP	26.0 CFM	Over 16 oz./min.	13"	E (.070") or D (.086")

* Viscosity Cup Reference

18 Seconds #4 Ford = 22 Seconds ZAHN #2

22 Seconds #4 Ford = 24 Seconds ZAHN #2





28 Seconds #4 Ford = 30 Seconds ZAHN #2

** Spray pattern size dependent upon type of feed, material viscosity, and air cap pressure.

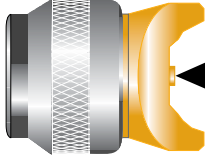

Note: MBC-368 Retaining ring must be ordered separately.

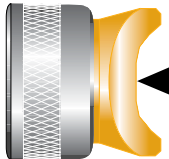
HVLP Air Cap & Tip Selection Chart

EGHV and TGHV

TYPICAL COATINGS USED WITH	TYPICAL SOLIDS BY VOLUME VISCOSITIES*	AIR CAP MODEL NO. PART NO.	AIR VOLUME (AT 10 psi AIR CAP PRESSURE)	TYPICAL FLUID FLOW RATES	PATTERN SIZE**	RECOMMENDED FLUID TIPS
Detail, touch-up enamels, lacquers, etc.	Low solids, up to 25% solids by volume Up to 24 seconds, #4 Ford cup	#397HV EGHV-439-397HV	 8.8 CFM	Up to 6 oz./min.	 Up to 6"	E (.070")
Detail, touch-up enamels, lacquers, etc.	Low solids, up to 25% solids by volume Up to 24 seconds, #4 Ford cup	#90HV CV-39-90HV	 6.7 CFM	Up to 4 oz./min.	 Up to 5"	F (.041")

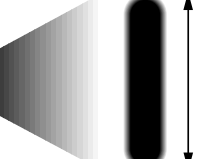
JGA-HVLP AND GFG-HVLP

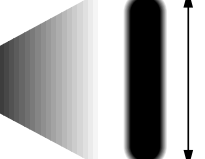
TYPICAL COATINGS USED WITH	TYPICAL SOLIDS BY VOLUME VISCOSITIES*	AIR CAP MODEL NO. PART NO.	AIR VOLUME (AT 10 psi AIR CAP PRESSURE)	TYPICAL FLUID FLOW RATES	PATTERN SIZE**	RECOMMENDED FLUID TIPS
Most common low solids coatings, i.e. enamels, lacquers, stains, sealers, primers, waterbornes, etc.	Low solids, up to 30% solids by volume Up to 24 sec., #4 Ford cup	#98 JGHV-101-98	 11 CFM	Up To 8 oz./min.	 11 1/2"	Pressure Feed • FX (.042")
Most common low solids coatings, i.e., automotive refinish materials, enamels, lacquers, stains, sealers, primers, waterbornes, etc.	Low solids, up to 30% solids by volume Up to 24 sec., #4 Ford cup	#57 JGHV-101-57	 22 CFM	Up to 12 oz./min. (gravity) 8 oz./min. (suction)	 10" - 11"	Gravity Feed • DFF (.055") • DFW (.063") • DE (.070") Suction Feed • D (.086") • DE (.070")

* Viscosity Cup Reference: 18 Seconds #4 Ford = 22 Seconds ZAHN #2
22 Seconds #4 Ford = 24 Seconds ZAHN #2
28 Seconds #4 Ford = 30 Seconds ZAHN #2

** Spray pattern size dependent upon type of feed, material viscosity, and air cap pressure.

Conventional Series Features and Benefits

Durability

- 1 300-grade stainless steel fluid passages offer waterborne compatibility, corrosion resistance and protection from harsh, self-etching primers.
- 2 Drop forged aluminum gun bodies are strong, durable and lightweight.
- 3 Trigger strike pad makes trigger action smooth and extends air valve life.
- 4 Trigger is designed with reinforced wear points.
- 5 All gun components have been life cycle tested to ensure reliability in production environments.
- 6 Long-life needle packings.

Performance

- 7 Dual-seal fluid inlet assures a positive seal.
- 8 Cartridge-type air valve is designed for positive sealing and quick trigger action.
- 9 Lightweight and precision-balanced for operator comfort.
 - Sized to fit both the operator and the application, in standard-size and mid-size models.

Easy to Use

- 10 Large “two-finger” trigger provides light trigger action for easy operation and comfort.
- 11 Knurled knobs for easy adjustment of pattern and fluid flow.
- 12 1/4" air inlet connects to any standard compressor system.

Maintenance

- 13 Replaceable baffle with aluminum air cap retaining ring threads eliminates the need to replace the gun body, should threads become damaged.
- 14 Simple, straightforward design for easy care and maintenance.
- 15 Economical replacement parts are available and easy to install.

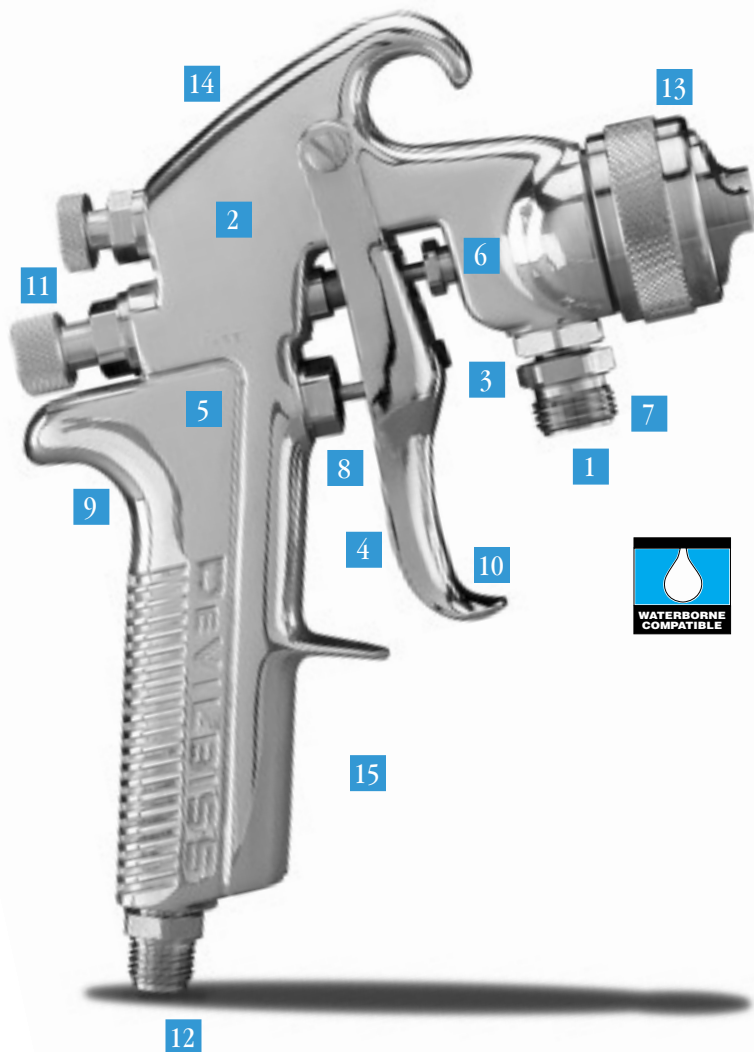

Selecting Conventional Air Spray Guns

GUN MODEL	USAGE/MATERIALS	PAGE NO.	FEED TYPE	CONSTRUCTION	
				BODY	WETTED PARTS
<i>Manual Spray High Production</i>					
JGA-510	General Purpose, Standard Finishes	20	Pressure Suction	Drop-Forged Aluminum	300, 400-Grade Stainless Steel
MSA-510	General Purpose, Standard Finishes	21	Pressure Suction	Drop-Forged Aluminum	300, 400-Grade Stainless Steel
MBC-510	General Purpose, Standard Finishes	22	Pressure Suction	Drop-Forged Aluminum	400-Grade Stainless Steel Plated Brass
<i>Manual Spray Special Purpose</i>					
EGA-503	Detail, Touch-Up, Standard Finishes	23	Pressure Suction	Drop-Forged Aluminum	400-Grade Stainless Steel Aluminum
GFG-618	Gravity Feed Standard Finishes	24	Gravity	Drop-Forged Aluminum	300, 400-Grade Stainless Steel, Aluminum Cup
<i>Automatic Spray</i>					
AGX-550	Most Common Materials	25	Pressure Circulating	Machined Aluminum	300, 400-Grade Stainless Steel Teflon®
AGX-552	Abrasive Materials	25	Pressure Circulating	Machined Aluminum	300, 400-Grade Stainless Steel Carbolloy, Teflon®
AGX-553*	Waterbornes, Mildly Abrasive/Corrosive Mtrls.	25	Pressure Circulating	Machined Aluminum	300-Grade Stainless Steel Teflon®
AGF-506	Compact, Standard Finishes	26	Pressure	Cast Alloy (Aluminum)	400-Grade Stainless Steel, Aluminum

* Models include "premium" fluid tip constructed of 300-grade stainless steel with U.H.M.W. polyethylene insert (needle seat) for extended service life.

JGA Standard-Size Manual Spray Gun

Setting industry standards for high-production performance, the JGA standard-size manual spray gun also offers the comfortable fit and feel operators prefer. An economical option for waterborne and solvent-based material applications, the JGA stainless steel air spray gun delivers the quality results you need for tough applications.

- 300-grade stainless steel fluid passages offer waterborne compatibility, corrosion resistance and protection from harsh self-etching primers.

For gun, cap and tip information see charts on pages 28 & 29.

Productivity and Finish Quality

The productivity and finish quality of any DeVilbiss conventional air spray gun is determined by the air cap and fluid tip combination.

Ordering Information

The JGA standard-size spray gun is available with the following air cap and fluid tip set-ups, factory-assembled for immediate delivery. However, these are only the most popular set-ups – for other air cap and tip combinations that can be ordered separately, see the charts on pages 28 and 29.

Part No.	
JGA-510-30EX	JGA-510-765E
JGA-510-704E	JGA-510-765FF
JGA-510-704FF	JGA-510-765EX
JGA-510-704FX	JGA-510-797FF
	JGA-510-80EX



These guns with fluid tip and needle can be ordered separately without air cap and retaining ring:

Part No.	
JGA-510-D*	JGA-510-FX*
JGA-510-E*	JGA-510-FW*
JGA-510-EX*	JGA-510-3-FF**
JGA-510-FF*	JGA-510-3-FX**

* Models include 400-grade stainless steel tips and needles.

** Models include "premium" 300-grade stainless steel tip with U.H.M.W. polyethylene insert (needle seat) and 300-grade stainless steel needle.

When ordering DeVilbiss spray guns, the part number includes information on the specific gun model, air cap and fluid tip you will receive.

Example: JGA-510-

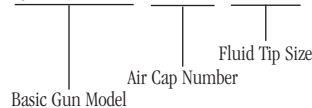

Technical Specifications

Body:	Drop forged aluminum
Weight:	21.6 oz. (613 gr) with air cap and ring
Air Inlet:	100 psi max, 1/4" NPS (M)
Fluid Inlet:	150 psi max, 3/8" NPS (M)
Fluid Passages:	300-grade stainless steel
Feed Type:	Pressure feed Suction feed (EX)
Service Bulletin:	SB-2-252
Gun Repair Kit:	KK-4987-2

Accessories

- Hose assemblies, air control, pressure tanks, cups, gun and hose cleaning equipment and other accessories are also available.
- For optional tip and needle sets, see page 29.

MBC-510 Manual Spray Gun With Removable-Head

Combining a drop forged aluminum body with a forged removable spray head, the MBC-510 spray gun is ideal for applications that require maximum output and quick changeovers.

- Removable spray head allows for reduced downtime on nozzle combination changeovers.
- MBC spray guns have nickel-plated brass fluid passages and 400-grade stainless steel fluid tip and needle.

For gun, cap and tip information see charts on pages 28 & 29.

Productivity and Finish Quality

The productivity and finish quality of any DeVilbiss conventional air spray gun is determined by the air cap and fluid tip combination

Technical Specifications

Body:	Drop forged aluminum
Weight:	27 oz. (756 gr) with air cap and ring
Air Inlet: (M)	100 psi max, 1/4" NPS
Fluid Inlet: (M)	100 psi max, 3/8" NPS
Fluid Passages:	Nickel-plated brass
Wetted Parts:	Nickel-plated brass 400-grade stainless steel
Feed Type:	Pressure feed Suction feed
Service Bulletin:	SB-2-301
Gun Repair Kit:	KK-4058-1

Accessories

- Hose assemblies, air control, pressure tanks, cups, gun and hose cleaning equipment and other accessories are available.

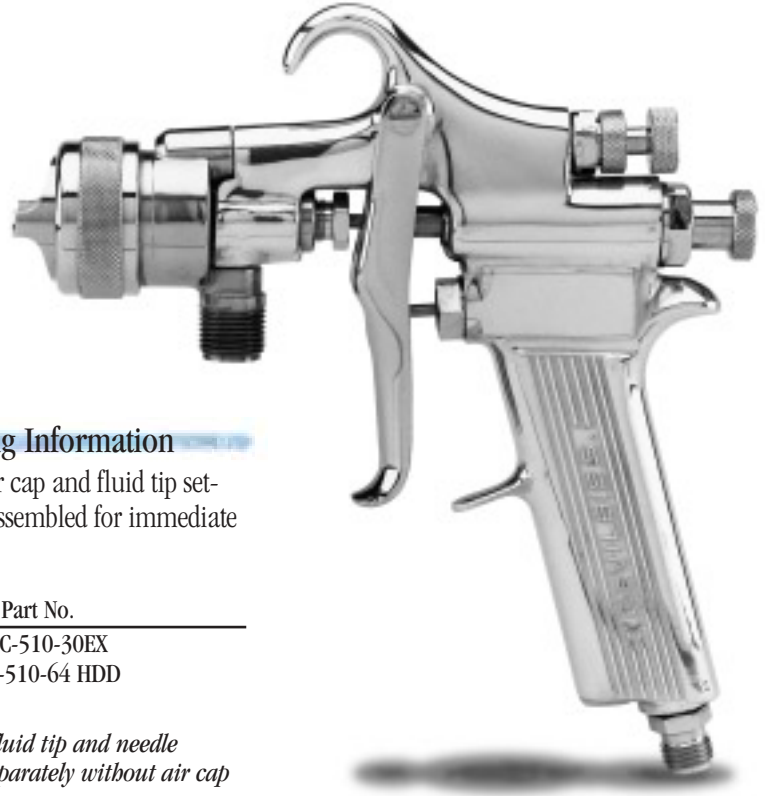

Ordering Information

The following air cap and fluid tip set-ups are factory assembled for immediate delivery.

Part No.

MBC-510-30EX
MBC-510-64 HDD

These guns with fluid tip and needle can be ordered separately without air cap and retaining ring:

Part No.

MBC-510-AC	MBC-510-EX
MBC-510-D	MBC-510-FF
MBC-510-E	MBC-510-FX

When ordering DeVilbiss spray guns, the part number includes information on the specific gun model, air cap and fluid tip you will receive.

Example: MBC-510-

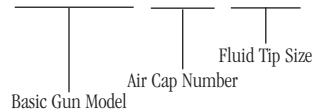

EGA Touch-Up Manual Spray Gun

The gun of choice for touch-up, shading, edging and detail decorating, the EGA touch-up gun provides precise control for any type of delicate spray finishing applications. The gun features a forefinger trigger to enhance operator control, and a long needle taper to make detail work easy.

- Equipped with stainless steel tip and needle.
- Knurled knobs allow fine spray adjustments for fluid and pattern control.

Productivity and Finish Quality

The productivity and finish quality of any DeVilbiss conventional air spray gun is determined by the air cap and fluid tip combination.

Ordering Information

The EGA touch-up gun is available with the following air cap and fluid tip set-up, factory-assembled for immediate delivery.

Part No.

EGA-503-390F



For gun, cap and tip information see charts on pages 28 & 29.

Technical Specifications

Body:	Drop forged aluminum
Weight:	7 oz. (196 gr) with air cap and ring
Air Inlet:	1/4" NPS (M)
Fluid Inlet:	1/4" NPS (M)
Wetted Parts:	Aluminum 400-grade stainless steel
Feed Type:	Pressure feed Suction feed
Service Bulletin:	SB-2-163
Gun Repair Kit:	KK-5044

Accessories

- Hose assemblies, air control, pressure tanks, cups, gun and hose cleaning equipment and other accessories are also available.

GFG Gravity Feed Manual Spray Gun

Combining the advantages of gravity feed fluid delivery with advanced quality and performance, the GFG-618 conventional air spray gun offers high transfer efficiency for small applications that require full, uniform coverage. Fitted with a top-mounted gravity feed cup that makes filling simple and quick, the GFG-618 spray gun uses virtually every drop of paint in the cup, even when working with very small amounts of material.

For gun, cap and tip information see charts on pages 28 & 29.

- 300-grade stainless steel fluid passages offer waterborne compatibility,

corrosion resistance and protection from harsh self-etching primers.

- Standard equipment includes a 32 ounce aluminum cup and booth-mount gun hook.
- Includes E-Z Liner™ disposable cup liners to speed-up cleaning, and allows upside-down spraying.
- Drip check in the cup lid virtually eliminates leaks and spills from the vent hole.

Productivity and Finish Quality

The productivity and finish quality of any DeVilbiss conventional air spray gun is determined by the air cap and fluid tip combination.

Ordering Information

The GFG-618 gravity feed spray gun and cup is available with the following air cap and fluid tip set-ups, factory-assembled for immediate delivery.

Part No.
GFG-618-80FW
GFG-618-90FF*
GFG-618-90FW*

* Models include #9000 air cap.

See pages 28 and 29 for Air Cap, Tip and Needle Selection Guide.



Shown with E-Z Liner™ disposable cup liner



When ordering DeVilbiss spray guns, the part number includes information on the specific gun model, air cap and fluid tip you will receive.

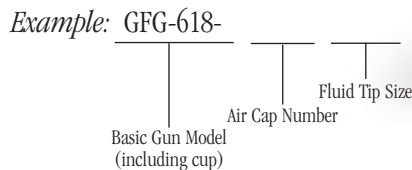

Technical Specifications

Body:	Drop forged aluminum
Weight:	27.5 oz. (770 gr) with paint cup
Air Inlet:	100 psi max, 1/4" NPS (M)
Fluid Inlet:	3/8" BSP (F)
Wetted Parts:	300 and 400-grade stainless steel, aluminum cup
Feed Type:	Gravity feed
Service Bulletin:	SB-2-179
Gun Repair Kit:	KK-5025

Accessories

- 20 oz. delrin cup (GFC-501)
- 32 oz. aluminum cup (GFC-502).
- Disposable E-Z Liner™ cup liners (OMX-70-K48)
- Hose assemblies, air control, gun and hose cleaning equipment and other accessories are also available.

AGX Automatic Spray Gun



When ordering DeVilbiss spray guns, the part number includes information on the specific gun model, air cap and fluid tip you will receive.

Example: AGX-5XX-

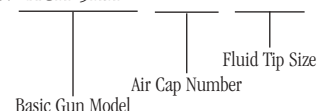

For gun, cap and tip information see charts on pages 28 & 29.

Built to withstand the rigors of high-speed production lines and harsh finishing conditions, the AGX automatic air spray gun is engineered for rugged reliability. Designed for use with industrial robots, reciprocators and stationary mounting, the AGX spray gun's compact size allows mounting in tight areas.

- Simplified gun design for greater reliability and ease of maintenance.
- Detachable spray head for fast needle packing replacement.
- AGX-550 spray gun comes with a 400-grade stainless steel tip for use with many waterborne materials and chlorinated solvents. AGX-552 guns are specially equipped with carbolloy fluid tip and needle for use with water-mix materials and abrasives. AGX-553 guns include "premium" 300-grade stainless steel fluid tip with U.H.M.W. polyethylene insert (needle seat) and 300-grade stainless steel needle for use with mildly abrasive or corrosive materials. All AGX models include 300-grade stainless steel fluid passages.
- Circulating capability standard.

Productivity and Finish Quality

The productivity and finish quality of any DeVilbiss conventional air spray gun is determined by the air cap and fluid tip combination.

Ordering Information

AGX spray guns are available with the following air cap and fluid tip set-ups, factory-assembled for immediate delivery.

Part No.

AGX-550-704E
AGX-550-704FF
AGX-550-704FX

These guns with fluid tip and needle can be ordered separately without air cap and retaining ring:

Part No.

AGX-550-AC	AGX-552-D
AGX-550-D	AGX-552-EE
AGX-550-E	AGX-552-FF
AGX-550-FF	AGX-553-E
AGX-550-FX	AGX-553-FF
AGX-550-G	AGX-553-FX
AGX-552-AC	

See pages 28 and 29 for Air Cap, Tip and Needle Selection Guide.

Technical Specifications

Body:	Machined aluminum
Weight:	26 oz. (728 gr) without mounting stud 30.5 oz. (854 gr) with mounting stud
Air Inlet:	100 psi max, 1/4" NPS (M)
Cylinder Air Pressure:	100 psi max, 50 psi min.
Fluid Inlet:	100 psi max, 3/8" NPS (M)
Wetted Parts:	
AGX-550	300 & 400-grade stainless steel, Teflon®
AGX-552	300 & 400-grade stainless steel, Carbolloy, U.H.M.W. polyethylene
AGX-553	300-grade stainless steel, U.H.M.W. polyethylene, Teflon®
Mounting Stud:	3/4" dia.
Service Bulletin:	SB-2-624
Gun Repair Kit:	KK-4992-1

Accessories

- Convert to HVLP by changing the spray head, air cap and baffle. See Service Bulletin SB-2-628.
- Fluid regulators, fluid strainers, air control, gun and hose cleaning equipment and other accessories are also available.
- KK-5046 Mounting block kit for mounting gun on 1/2" rod.
- Fan control kit – for remote operation (KK-4955)

AGF Compact Automatic Spray Gun

The AGF compact automatic air spray gun is designed for use with conventional materials. Ideal for applying coatings and finishes to small manufactured parts, the AGF spray gun works well in a wide range of automatic and semi-automatic production situations.

- Compact gun size allows mounting in limited spaces.
- Adaptable to multi-gun configuration environments.

Productivity and Finish Quality

The productivity and finish quality of any DeVilbiss conventional air spray gun is determined by the air cap and fluid tip combination.

For gun, cap and tip information see charts on pages 28 & 29.

Ordering Information

AGF-506 spray guns are available with the following air cap and fluid tip set-ups, factory-assembled for immediate delivery.

Part No.
AGF-506-90F
AGF-506-92E

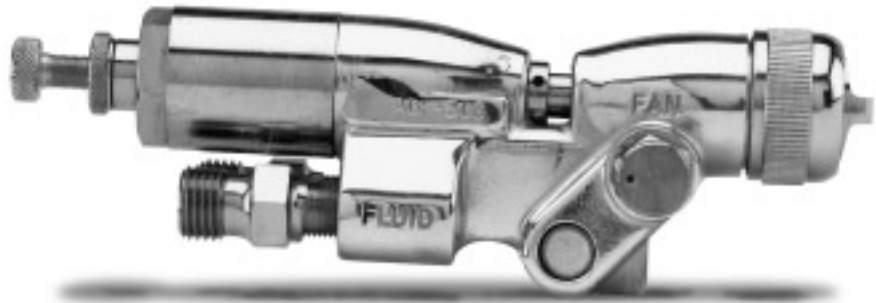

When ordering DeVilbiss spray guns, the part number includes information on the specific gun model, air cap and fluid tip you will receive.

Example: AGF-506-

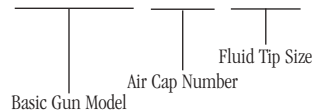

See pages 28 and 29 for Air Cap, Tip and Needle Selection Guide.

Technical Specifications

Body:	Cast aluminum alloy
Weight:	16 oz. (448 gr)
Air Inlet:	100 PSI Max, 1/4" NPS (M)
Fluid Inlet:	100 PSI Max, 1/4" NPS (M)
Wetted Parts:	Aluminum 400-grade stainless steel
Mounting Hole:	3/8" dia.
Piston Op. Pressure:	60 psi min.
Service Bulletin:	SB-2-781

Accessories

- Fluid regulators, fluid strainers, air control, gun and hose cleaning equipment and other accessories are also available.

DGD-515 Duster Gun

The DGD-515 duster gun, constructed of reinforced composite material, features an angled extended nozzle for effective removal of dirt from flat and recessed surfaces. Its lightweight, ergonomic design features a comfortable, four finger trigger with variable trigger flow and complies with OSHA federal safety standards.

Technical Specifications

Air Inlet:	1/4" NPT
Maximum Inlet Pressure:	185 psi
Air Consumption:	11 cfm @ 50 psi
Service Bulletin:	SB-3-146



Selecting the Air Cap, Fluid Tip and Needle

The air cap directs compressed air into the material stream to atomize the fluid and form the spray pattern. The fluid tip and needle meter direct the flow of material from the gun into the air stream.

Because they all affect the quality of the spray pattern, the air cap, fluid tip and needle are usually selected as a unit. Together, these three items are referred to as the nozzle combination.

Types of Air Caps

Air caps are defined by their methods of delivering and mixing the spray finishing materials. Delivery methods include pressure feed, suction feed and gravity feed. *Chart 1 depicts flow rate range, fluid tip size and recommended air caps for a typical product finish. See page 28 for more air cap details.*

Types of Fluid Tips

Fluid tips are made from a variety of metals. The application determines the type of fluid tip to use. Stainless steel tips are ideal for corrosive materials. The

standard tip on most DeVilbiss guns is 400-grade stainless steel; 300-grade “premium” fluid tips with U.H.M.W. polyethylene insert (needle seat) are also available. We also offer carbolloy fluid tips for extremely abrasive materials.

The amount of material discharged from a pressure feed gun depends on a number of factors: the material viscosity, the fluid tip inside diameter, the length and size of hose, and the pressure on the material. Generally, the larger the opening, the more material discharged.

However, if the fluid tip is too large, the operator will lose control over the material discharge. And if the fluid tip opening is too small, the discharge velocity will be too high. This means the air coming from the cap will not atomize the material properly, and the pattern will be distorted.

With a suction feed gun, the fluid flow in ounces per minute is relatively stable because it is determined by atmospheric pressure. It is also determined by the material viscosity and air cap pressure.

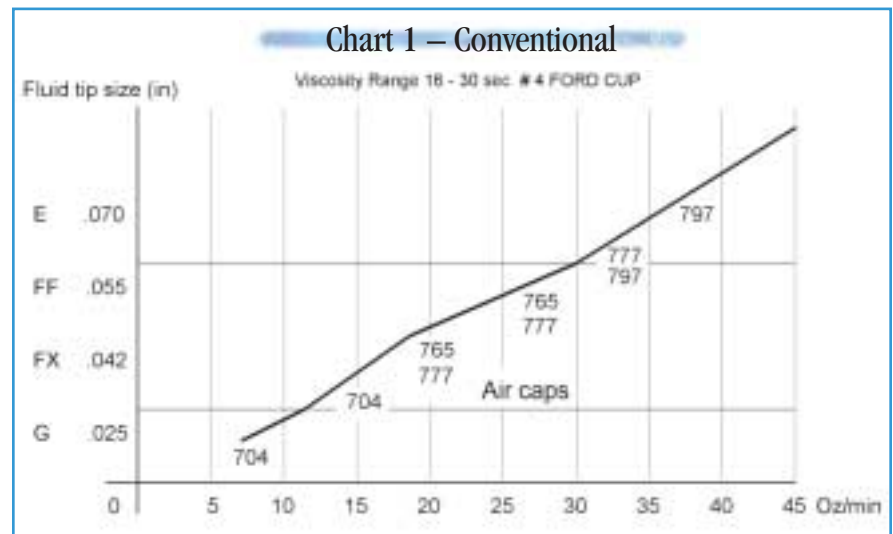

Chart 2 – Flow Rates for Fluid Tips

Fluid Tip	ID Size in (mm)	Flow Rate Or Material
Pressure Feed		
G	.028" (.70)	Up to 12 oz./min.
GX	.034" (.85)	Up to 16 oz./min.
F	.041" (1.0)	Up to 18 oz./min.
FX	.042" (1.1)	Up to 20 oz./min.
FF	.055" (1.4)	Up to 30 oz./min.
FW	.062" (1.6)	Up to 35 oz./min.
E	.070" (1.8)	40 oz./min. and over
EE	.070" (1.8)	Porcelain enamel
D	.086" (2.2)	Heavy-body materials
AC	.110" (2.8)	Heavy-body materials
Suction Feed		
EX	.070" (1.8)	Up to 12 oz./min.
Gravity Feed		
FF	.055" (1.4)	Up to 12 oz./min.
FW	.062" (1.6)	Up to 14 oz./min.

Air Cap Selection Guide

TYPICAL MATERIALS	VISCOSITY RANGE ⁽¹⁾			AIR CAP MODEL NO.	AIR CAP PART NO.	OPERATING RANGE		TYPICAL PATTERN SIZE IN. (MM)	FLUID TIP NO. & SIZE IN. (MM)	TYPE OF FEED ⁽²⁾
	LOW	MED	HIGH			PSI	SCFM			
Adhesives		•	•	24	AV-40-24 ⁽³⁾	50	14	4-7 (100-175)	D .086 (2.2) E .070 (1.8) FF .055 (1.4)	P
Enamels, Lacquers, Metallics	•	•		30	MB-4039-30 ⁽⁹⁾	50	12	8-10 (200-250)	EX .070 (1.8) FF .055 (1.4) FX .042 (1.1)	S
Gen. Purpose	•	•		35L	AV-1239-35L ⁽⁴⁾	50	4.8	4-6 (100-150)	E .070 (1.8) FF .055 (1.4) FX .042 (1.1)	P, S
Gen. Purpose, Enamels, Lacquers	•			58	AV-439-58 ⁽⁹⁾	40	6	9 (225)	E .070 (1.8) EX .070 (1.8) FF .055 (1.4) FX .042 (1.1)	P, S
Heavy Body			•	62HD	MB-4039-62HD ⁽⁹⁾	80	19	8 (200)	AC .110 (2.8)	P
Porcelain Glazes			•	64HD	MB-4039-64HD ⁽⁹⁾	80	22	13-14 (325-350)	D .086 (2.2)	P
Gen. Purpose, Enamels, Lacquers	•	•		80	MB-4039-80 ⁽⁹⁾	60	14	13 (325)	EX .070 (1.8) FW .062 (1.6) FF .055 (1.4)	S, G
Gen. Purpose, All Finishes		•		704	AV-1239-704 ⁽⁵⁾	70	21	10-12 (250-300)	E .070 (1.8) FF .055 (1.4) FX .042 (1.1)	P
Metallics, High Solids		•	•	765	AV-1239-765 ⁽⁵⁾	80	22	15 (375)	E .070 (1.8) FF .055 (1.4)	P
Automotive, High Solids, Base/Clear Coats, Urethanes		•	•	777	31767-777 ⁽⁵⁾	70	23	13-14 (325-350)	E .070 (1.8) FF .055 (1.4)	P
Automotive, Metallics High Solids		•	•	797	AV-1239-797 ⁽⁵⁾	70	21	17 (425)	E .070 (1.8) FF .055 (1.4)	P
Gen. Purpose, Automotive Finishes	•	•	•	9000	AV-440-9000 ⁽⁹⁾ AV-9000 ⁽¹⁰⁾	45	12	10 (250)	FW .062 (1.6) FF .055 (1.4)	G, S
Gen. Purpose, Stains, Lacquer Sealers	•			90 ⁽⁷⁾	CV-39-90 ⁽⁵⁾	40	4	4.5 (112)	F .042 (1.1)	P, S
Heavy Body, Primers		•	•	92 ⁽⁷⁾	CV-439-92 ⁽⁹⁾	50	6	4.5 (112)	E .070 (1.8)	P, S
Detail, Touch-Up, Stains, Lacquer	•			390 ⁽⁸⁾	EGA-40-390 ⁽⁶⁾	30	3	3 (75)	F .042 (1.1)	P, S

(1) Viscosity Cup Reference:
 Low = Up to 23 Seconds ZAHN #2
 Medium = 23-28 Seconds ZAHN #2
 High = 28+ Seconds ZAHN #2

(2) Type of Feed Reference:
 G = Gravity
 P = Pressure
 S = Suction

(3) Retaining Ring Required: Part No. MBC-368 or MSA-1
 (4) Retaining Ring Required: Part No. MSA-1 or MBC-368
 (5) Retaining Ring Required: Part No. TGA-31
 (6) Retaining Ring Required: Part No. EGA-11
 (7) Used with AGF-506 Automatic Spray Gun
 (8) Used with EGA-503 Manual Spray Gun
 (9) Includes Retaining Ring
 (10) Retaining Ring Required: Part No. MBC-368 or MSA-1

Fluid Tip and Needle Selection Guide

GUN MODEL	FLUID TIP	TIP PART NO. ^(1,2)	NEEDLE PART NO.	LAPPED SET PART NO.
400-Grade Stainless Steel Tips and Needles				
JGA-510	AC	AV-650-AC	JGA-402-C	JGA-4040-AC
MSA-510	D	AV-650-D	JGA-402-DEX	JGA-4040-D
GFG-618	E	AV-650-E	JGA-402-E	JGA-4040-E
	EX	AV-650-EX	JGA-402-DEX	JGA-4040-EX ⁽³⁾
	FF	AV-650-FF	JGA-402-FF	JGA-4040-FF
	FW	AV-650-FW	JGA-402-FF	JGA-4040-FW ⁽³⁾
	FX	AV-650-FX	JGA-402-FX	JGA-4040-FX
	GX	AV-650-GX	JGA-402-GX	JGA-4040-GX
MBC-510	AC	AV-650-AC	MBC-496-C	—
	D	AV-650-D	MBC-496-DEX	MBC-4395-D
	E	AV-650-E	MBC-444-E	MBC-4395-E
	EX	AV-650-EX	MBC-496-DEX	—
	FF	AV-650-FF	MBC-444-FF	MBC-4395-FF
	FX	AV-650-FX	MBC-444-FX	MBC-4395-FX
EGA-503	E	—	—	EGA-4000-E
	F	—	—	EGA-4000-F
AGX-550	AC	—	—	AGX-4402-AC
	D	—	—	AGX-4402-D
	E	—	—	AGX-4402-E
	FF	—	—	AGX-4402-FF
	FX	—	—	AGX-4402-FX
	G	—	—	AGX-4402-G
AGF-506	E	CV-30-E	AGF-404-E	—
	F	CV-30-F	AGF-404-F	—
300-Grade Stainless Steel Tips and Needles (Tip includes U.H.M.W. polyethylene insert)				
JGA-510	D	—	JGA-421-DEX	JGA-4056-D ⁽³⁾
MSA-510	E	—	JGA-421-E	JGA-4056-E ⁽³⁾
	FF	—	JGA-421-FF	JGA-4056-FF ⁽³⁾
	FX	—	JGA-421-FX	JGA-4056-FX ⁽³⁾
	G	—	JGA-421-G	JGA-4056-G ⁽³⁾
AGX-553	E	—	—	AGX-4300-E ⁽³⁾
	FF	—	—	AGX-4300-FF ⁽³⁾
	FX	—	—	AGX-4300-FX ⁽³⁾
MBC-510	D	—	—	MBC-4397-D ⁽³⁾
	E	—	—	MBC-4397-E ⁽³⁾
	FF	—	—	MBC-4397-FF ⁽³⁾
Carbolloy Tips and Needles				
JGA-510	AC	AV-617-AC	—	—
MSA-510	D	AV-617-D	JGA-409-D	—
GFG-618	EE	AV-617-EE	JGA-409-DEEE	—
	FF	AV-617-FF	JGA-409-FF	—
AGX-552	D	—	—	AGX-4410-D
	EE	—	—	AGX-4410-EE
	FF	—	—	AGX-4410-FF

Fluid Tip Replacement Guide

To assure a leak-free seal, lapped tip and needle sets are recommended (see selection chart). However, you can also order individual tips with gaskets. To replace an individual fluid tip, point the tip straight up and look for the part number on the outermost surface.

OLD TIP NO.	ORDER NEW TIP/GASKET NO.
AV-15-xx	AV-650-xx
AV-1115-xx	AV-650-xx
AV-1415-xx	AV-617-xx
AV-2115-xx	AV-650-xx

xx = Insert letters to indicate the fluid tip size:
G, GX, FX, FF, E, EE, EX, D, AC or FX.

- (1) AV-601 and AV-641 fluid tips have been replaced by the AV-650 tip.
- (2) To order AV tip replacements, refer to the Fluid Tip Replacement Guide on this page.
- (3) Matched tip and needle set.

Pressure, Suction and Gravity Feed Cups



**Stainless Steel Pressure Feed Cup
KB-545-SS**

**Aluminum Pressure Feed Cup
KB-555**

KB II Series 2-quart cups feature a “pistol grip” carrying handle, and right- or left-handed design for comfort and ease of handling. An easy-open lid and wide cup mouth allow for fast filling and cleanup. KB II Series cups also feature a solvent-resistant check valve, a 0-30 psi air gauge and a wide base for greater stability.

KB II Cups are supplied with disposable cup liners, which reduce clean-up and solvent use. The unique lid liner also protects the underside of the lid, preventing check valve problems. Order KK-5051 (Box of 20 Liners).

Typical use: Ideal for a wide variety of materials and a broad range of fluid flows. Fluid pressure range of 2-30 psi.

- KB-545-SS stainless steel cup is designed for use with waterbornes, halogenated hydrocarbons and other corrosive materials.
- KB-555 aluminum cup is compatible with most coating materials and solvents.

Air/Fluid Hose: Order assemblies separately. Part KB-4006 for 6' hose lengths.



**20 oz. Acetal Gravity Feed Cup
GFC-501**



**32 oz. Aluminum Gravity Feed Cup
GFC-502**

DeVilbiss gravity feed cups are made of strong, lightweight acetal, or aluminum for durability. In addition, an integral drip check in the cup lid virtually eliminates leaks from the vent hole. These cups can be used with E-Z Liner™ disposable cup liners, which reduce clean-up time and solvent use. Order liner kit OMX-70-K48.



**Teflon-Lined Suction Cup
TLC-555**

Aluminum 1-quart cup featuring a Teflon® lining for fast, easy cleaning and reduced color contamination. The lid design has a two-position valve which allows for operation as a “drip-free” cup or as a conventional suction cup. For use with all suction feed spray guns.



**Stainless Steel Suction Cup
TSC-595**

Made from 300-grade stainless steel, this 1-quart cup is designed for use with water-based materials and exempt solvents. The .030" wall thickness makes it more durable than competitive cups, yet it is still lightweight. And the fluid tube is stainless steel for added durability and corrosion resistance.

Low Pressure Cups

TLC-576*

Aluminum 1-quart low pressure, Teflon®-lined for fast, easy cleaning.

TSC-591*

Stainless steel 1-quart low pressure.

** Requires KK-4980 for cup air regulation (order separately).*



Pressure, Suction and Gravity Feed Cups

(Continued)



1-Quart Aluminum Suction Cup
TGC-545



1-Pint Aluminum Suction Cup
TGC-536



8 oz. Polyethylene Suction Cup
TGS-503

Aluminum suction cups incorporate a two-position valve, which allows for operation as a “drip-free” cup or as a conventional suction feed cup. Smooth metal surfaces make cleanup and changeovers fast and easy. For use with all suction feed spray guns.

This 8 oz. cup combines an engineered resin lid with a translucent polyethylene cup that lets you see the liquid level. Lightweight and easy to clean, the non-staining cup has molded-in graduations for mixing ratios. Compatible with all solvents, it fits any suction feed gun with 1/4" NPS threads. Use an AD-404 adapter to adapt to spray guns with 3/8" NPS (M) inlets.

Paint Cup Selection Guide

COMPLETE CUP ASSEMBLY PART NO.	CAPACITY	MATERIAL	FLUID CONNECTION	CUP ONLY PART NO.	SHIPPING WEIGHT ⁽¹⁾
<i>Pressure Feed</i>					
KB-555	2 qt.	Aluminum	3/8" NPS (M) ⁽²⁾	KB-422	3 lb. 14 oz.
KB-545-SS	2 qt.	Stainless Steel	3/8" NPS (M) ⁽²⁾	KB-442	5 lb. 2 oz.
TLC-576 ⁽⁵⁾	1 qt.	Teflon®- lined Aluminum	3/8" NPS (F)	TLC-401	18 oz.
TSC-591 ⁽⁵⁾	1 qt.	Stainless Steel	3/8" NPS (F)	TSC-400	20 oz.
<i>Suction Feed</i>					
TGC-536	1 pt.	Aluminum	3/8" NPS (F)	TGC-432	12 oz.
TGC-545	1 qt.	Aluminum	3/8" NPS (F)	KR-428-2	18 oz.
TGS-503 ⁽³⁾	8 oz.	Polyethylene	1/4" NPS (F)	See Note ⁽³⁾	3 oz.
TLC-555	1 qt.	Teflon®- lined Aluminum	3/8" NPS (F)	TLC-401	18 oz.
TSC-595	1 qt.	Stainless Steel	3/8" NPS (F)	TSC-400	20 oz.
<i>Gravity Feed</i>					
GFC-501 ⁽⁴⁾	20 oz.	Acetal	3/8" BSP (M)	N/A	6 oz.
GFC-502 ⁽⁴⁾	32 oz.	Aluminum	3/8" BSP (M)	N/A	9.4 oz.

(1) Approximate shipping weight for complete cup and lid assembly.

(2) Air connection thread size is 1/4" NPS (M).

(3) For cup and cover assembly, order part TGS-406.

(4) Use with GFG guns only.

(5) Order KK-4980 Regulator Kit in addition to the cup.

Air Control Accessories



Air Control Regulator HARG-510

The HARG-510 air control regulator and gauge combination fits any professional spray gun and is comfortable for both right- and left-handed operators. Precise and lightweight, this unit provides superior color matching capability. A swivel adapter allows fast installation, and a lock ring secures pressure settings to avoid inadvertent adjustment during spraying. Not recommended for HVLP spray guns.

Specifications

Valve Type: Diaphragm, relieving
Inlet Pressure: 250 psi max
Outlet Pressure Range: 5-100 psi
Regulator Gauge Ports (2): 1/8" NPT (F)



Air Adjusting Valve P-H-5516

This convenient air adjustment valve attaches directly to the spray gun air inlet. Commonly used with spray guns, pressure tanks and pumps, the valve features a large knurled knob for adjusting the airflow.



Air Regulator Lockout HAR-400

This device allows the painter to set the air regulator to guarantee proper atomization, as well as to assure compliance in areas where air cap pressure is limited to 10 psi or less. Includes one key per unit.



Air Adjusting Valve HAV-500



Air Adjusting Valve w/Gauge HAV-501

HAV air adjustment valves attach to the spray gun inlet, and allow the operator to control pressure at the gun. The HAV-501 includes an air gauge. The swivel top allows fast, easy installation. For use with all professional spray guns.

Air Control Selection Guide

Air Inlet = 1/4" NPS (M)
Air Outlet = 1/4" NPS (F) (Swivel)

PART NO.	NET WEIGHT	GAUGE RANGE	MAX. INLET PRESSURE	VALVE TYPE
HARG-510	10 oz.	0-160 psi	250	Diaphragm, Relieving
HAV-500	3.5 oz.	N/A	250	Straight
HAV-501	5 oz.	0-160 psi	250	With Gauge
P-H-5516	3 oz.	N/A	250	Straight

Air Quick Detachable Connectors

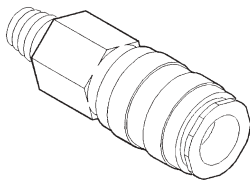

HC-4699

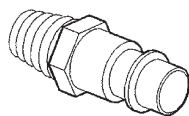

HC-1166

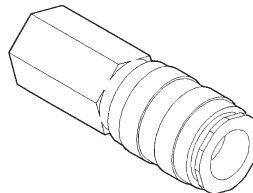

HC-4700

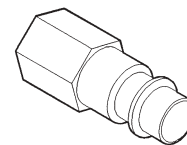

HC-4419

High Flow Air Connections

These connections improve the performance of any air tool by delivering greater air flow with less pressure drop, and are ideal for HVLP applications because they won't ever "starve" the spray gun. In addition, the quick-detach connection assures smooth, easy lock and release.

High Flow Q.D. Air Connectors & Stems

THREAD SIZE AND TYPE	PART NO.	MAX. WORKING PRESSURE (PSI)	MATERIAL OF CONSTRUCTION
1/4" NPT (M)	HC-4699	230	Plated Aluminum, Steel, Brass
1/4" NPT (M)	HC-1166	230	Plated Steel
1/4" NPT (F)	HC-4700	230	Plated Aluminum, Steel, Brass
1/4" NPS (F)	HC-4419	230	Plated Steel

Construction

Precision manufactured light-weight aluminum body, with durable hardened steel sleeve.

Air Spray Gun Accessories



SolventSaver™ Hose/Gun Cleaners

Simple, easy-to-use cleaners speed up equipment cleaning and save solvent (up to 86% savings!), which reduces VOC emissions. With SolventSaver, a finely atomized blast of solvent travels through the hose and gun fluid pas-

sages. Operated with compressed air, metering permits adjustment of the air/solvent mix. Units have 1/4" NPS (M) air and 3/8" NPS (M) fluid connections, and are equipped with a safety valve.

PART NO.	CAPACITY	SHIPPING WEIGHT	MAX. WORKING PRESSURE	FLUID PASSAGES MATERIALS CONSTRUCTION
HD-503*	2 qt.	5 lb.	50 psi	Aluminum, nickel-plated brass, Teflon® and Thiokol gaskets
QMGZ-5200*	2 gal.	42 lb.	110 psi	Galvanized steel, aluminum, nickel-plated brass, Teflon and santoprene gaskets, polyethylene tank liner

* Not suitable for use with chlorinated solvents, such as 1,1,1 trichloroethane or methylene chloride.

Fluid Strainers and Screens



In-Line Strainer VS-534

Stainless steel swivel strainer mounts to the tank or pump and has a 100 mesh replaceable, cylindrical filter.



Gun-Mounted Mini Strainer PLH-MF-6-100

Lightweight stainless steel final filter.



Gun-Mounted Strainer VS-531

This strainer is available in 100 mesh and can be attached to the gun inlet.



Gun-Mounted Strainer VS-532

Designed for use with JGA spray guns, this strainer mounts on the fluid inlet and allows the filter screen to be cleaned or replaced without removing the strainer housing. It also functions as a trigger guard.

STRAINER PART NO.	MAX. WORKING PRESSURE	INLET THREADS	OUTLET THREADS	WETTED PARTS	SCREEN PART NO.	MESH SIZE	MICRON SIZE
Gun Mounted Strainers							
VS-531	300	3/8"NPS(M)	3/8"NPS(F)	CS	31144-310-K10	100	149
VS-532	300	3/8"NPS(M)	3/8"NPS(F)	PB	VS-58-K10	100	149
Swivel							
Gun Mounted Mini Strainers							
PLH-MF-6-100	250	3/8"NPS(M)	3/8"NPS(F)	SS	PLH-MFC-100	100	149
In-Line or Tank/Pump Mounted Strainers							
VS-534	300	3/8"NPS(F)	3/8"NPS(M)	SS	VS-58-K10	100	149
Swivel							

SS = Stainless Steel
PB = Plated Brass
CS = Carbon Steel



Fluid Quick Detachable Connectors



Threaded Connector Q.D.'s

MALE THREAD	CONNECTION NUMBER	MAXIMUM WORKING PRESSURE	MATERIAL OF CONSTRUCTION
3/8" NPS	P-HC-4808-1	500	Aluminum
3/8" NPS	HC-513-1	500	Stainless Steel
3/8" NPS	QDL-4808	500	Delrin®, Stainless Steel

Male Stems for use with any Fluid Q.D. Connection

FEMALE THREAD	PASSAGE 1/4" I.D. STEM NO.	MAXIMUM WORKING PRESSURE	MATERIAL OF CONSTRUCTION
3/8" NPS Non-Swivel	P-HC-4482	750	Steel, Plated
3/8" NPS Swivel	HC-4691	500	Stainless Steel

Other Equipment and Accessories



Cleaning Brushes

For cleaning the threads and recesses of the gun body.

3/8" dia. brush: 42884-214-K5 (pkg. of 5)
 5/8" dia. brush: 42884-215-K10 (pkg. of 10)



Spray Gun Lube SSL-10-K12

Specially formulated spray gun lube improves performance and extends the life of spray equipment. Contains no silicones or petroleum distillates to contaminate paint and coatings. Case of 12 (2-oz.) bottles. Not for use with air tools and high RPM equipment.



Disposable Spray Gun Covers

Save money by reducing cleaning time and maintenance with these covers that also limit operator exposure to overspray.

GC-100-K4 (pkg. of 4)
 GC-100-K48 (pkg. of 48)

Paint Cup Gasket Kits

These kits contain replacement gaskets for pressure and suction feed cups.

Cup Model	TGC, TLC, TSC
Gasket Type	Tri-Seal
Kit Part No.	TGC-9-K5
Quantity	(pkg. of 5)

Cup Model	KB II
Gasket Type	Santoprene
Kit Part No.	KB-80-K5
Quantity	(pkg. of 5)



Mounting Stud AGA-414

Use this stud to attach automatic spray guns to 3/4" rods and increase the flexibility and versatility of your spray system. 16" long, 48 oz. (1344 gr) shipping weight.



JGA Gun Fluid Tube JGA-444

Handy tube combines the fluid and air hoses at the gun handle to prevent twisted lines and keep hoses from dragging over work. 3/8" NPS thread.



Thread Adapter

Thread adapters provide the correct hook-up for spray guns, hoses, tanks and other spray equipment. They work with most standard thread applications.

ADAPTER PART NO.	MALE	MALE	FEMALE
AD-404	—	1/4" NPS	3/8" NPS
P-H-4105	—	3/8" NPS	1/4" NPS
H-1766	1/8" NPT	1/4" NPS	—
H-2008	1/4" NPT	1/4" NPS	—
AD-31	1/4" NPS	1/4" NPS	—
AD-26	1/4" NPS	3/8" NPS	—
H-1580	1/4" NPT	3/8" NPS	—
H-1446	3/8" NPS	3/8" NPS	—
AD-11	3/8" NPS	3/8" NPT	—



Universal Clamp AGA-415

This clamp attaches directly to the gun stud and clamps onto 3/4" rod, allowing the gun to rotate to any angle. 13.5 oz. (378 gr) shipping weight.



Spray Gun Wrench WR-103

Versatile tool fits fluid and air hose connections, as well as adapters and packing nuts.

Multiple Parts Kits

Parts kits include replacement gaskets, o-rings, packings and seals for spray gun repair and maintenance.

SPRAY GUN	PARTS DESCRIPTION	QUANTITY PER PKG.	KIT PART NO.
MBC	Needle Packing	10	A-23-K10
MBC, AGX	Tip Gasket	5	AV-1-K5
MBC	Gasket	5	CV-5-K5
JGA, MSA, GFG	Needle Packing	3	JGV-463-K3
JGA, MSA, GFG	Needle Packing	5	JGA-4035-K5
JGA, MSA	Leather Packing	10	JGA-52-K10
JGA, MSA	Polyethylene Seal	10	JGD-14-K10
EGA	Needle Packing	5	38273-136-K5

System Solutions for Your Spray Finishing Needs



More than just a spray gun manufacturer, DeVilbiss is your single source for practical solutions to all your spray finishing challenges.

To maximize your production output you need consistent, reliable performance, high-quality results and a responsive service partner who knows the industry and your business. And with DeVilbiss, you also get the expertise.

Since 1888, we've advanced the science of spray finishing by introducing innovative products and technological developments that set the standards for the industry. These efforts help ensure that we can deliver the best solution for your particular spray finishing applications.

Spray Guns

- Conventional air spray and HVLV
- Standard-size, mid-size, manual and automatic
- Waterborne compatible, stainless steel passages
- Shading and touch-up guns for precision control
- Decorative guns for textured finish
- Duster guns for tough cleaning applications
- Gravity feed, suction feed, pressure feed
- Internal mix and external mix atomization methods

Cups and Tanks

- Pressure, gravity and suction feed cups
- Aluminum, stainless steel and polyethylene
- ASME-certified galvanized and stainless tanks
- Tank capacities from 2 gal. to 15 gal.
- Air motor drives

Air Control

- Regulators and gauges
- Adjusting valves
- Centrifugal, coalescing, in-line and desiccant filters

Hose

- Fluid and air hose
- Ball and air-adjusting valves
- Fittings and connections

Additional Accessories

- Thread adapters
- SolventSaver™ gun and hose cleaners
- Gun-mounted fluid strainers
- Replacement parts kits
- Air cap test kits
- Fluid regulators

Sales and Service
Through a Nationwide Network of Industrial Distributors



North American Office

World Headquarters
ITW Industrial Finishing
DeVilbiss
195 Internationale Blvd.
Glendale Heights, IL 60139
630-237-5000
Fax 630-237-5011
www.devilbiss.com

Customer Service

1-800-992-4657

Technical Assistance

1-888-992-4657
(USA and Canada only)



DEVILBISS
The Right Way To Finish™

