



BLASTMASTER® TORNADO INTERNAL PIPE BLASTING TOOL



PART NUMBERS AND SCHEMATICS GUIDE

Company Profile

Since 1944, Marco has developed a strong tradition of providing innovative and reliable products and services to the surface preparation and protective coatings industries. We are the world's premier provider of Abrasives, Blasting, Coating, Dust Collectors, Engineered Systems, Rental, Safety, Service, Repair, & Modernization, and Vacuums.

Through innovative designs and a total commitment to quality, Marco manufactures products that increase production rates, create a safer workplace, and reduce maintenance costs. Marco's industry experience, manufacturing capabilities, legendary customer service, product availability, logistics services, and technology leadership is your assurance that we deliver high quality products and services, providing the best value to you, our customer.

The Marco Difference

- **Industry Experience** – With Marco on your team, you have access to expertise which can only come from decades of industry leadership. We have organized our engineering department, production specialists, customer operations, and safety support into a “Center of Competence.” As a Marco customer, you have access to hundreds of years of cumulative experience related to your operations.
- **Manufacturing Excellence** – Marco is a U.S. based, ISO 9001:2008 certified manufacturer of equipment for the Surface Preparation and Protective Coatings industries. Marco's engineers benchmark the industry to ensure that we design and manufacture superior products that set the “Gold Standard” for performance, safety, and quality.
- **Legendary Customer Service** – Marco's legendary customer service team is staffed by friendly, highly-trained individuals who are focused on providing the highest level of product support, order accuracy, and customer satisfaction.
- **Product Availability** – We stock over 10,000 SKU's and have more than 45 shipping locations to serve North American and International markets for all major brands of blasting and coating equipment. As the largest provider of surface preparation and protective coatings equipment in the world, our inventory levels and product availability are unmatched.
- **Logistics Services** – Marco's in-house logistics team is dedicated to moving your shipment anywhere in the world. We move more than 14,000 truckloads every year, allowing you to save on freight costs by leveraging our buying power. Lower your process costs with a single invoice, which includes product and freight.
- **Technology Leadership** – Our website provides: Operator's Manuals, Part Numbers and Schematics Guides, SDS information, and Features & Specifications Guides, providing access to information 24/7. Our Extranet application allows you to receive quotes and place orders online. Our Intranet maintains a complete record of your purchase history to assist with ongoing support of your existing equipment and future purchasing decisions.

Vision Statement

Marco is the world's premier provider of Abrasives, Blasting, Coating, Dust Collectors, Engineered Systems, Rental, Safety, Service, Repair, & Modernization, and Vacuums.

Mission Statement

Marco provides strong leadership and innovation to the surface preparation and protective coatings industries. We dedicate our efforts to the continuous improvement of our products, services, processes, people, and most importantly, the quality of our customer's experience.

Quality Statement

Marco is committed to providing superior quality in the design, manufacturing, distribution, rental, service, and repair of our products. Our ISO 9001:2008 certification extends throughout all operations in all locations. Continuous improvement of our processes and supply chain Integration comprise the core of our business strategy for delivering exceptional quality and value in all Marco products and services.

Management Philosophy

We are a company dedicated to the success of every customer and associate. We discuss, debate, challenge, measure, and test our ideas. We will be boundless and limitless in our passion to improve. Through sound leadership and dedicated associates, we will ensure a long term, profitable future for Marco, our associates, customers, and suppliers.

TABLE OF CONTENTS

Company Profile	2
Table of Contents	3
Blastmaster® Tornado Internal Pipe Blasting Tool	4-7
Blastmaster® Tornado Internal Pipe Blasting Tool Part Numbers	4
Centering Carriage Part Numbers	5
Blastmaster® Tornado Internal Pipe Blasting Tool Part Numbers and Schematics	6-7
Optional Accessories	8-10
Pipe and Wheel Carriage for 12"–36" I.D.	8
Pipe and Wheel Carriage for 40"–60" I.D.	9
2" Tornado Large Rotating Head Assembly . .	10

PART NUMBERS AND SCHEMATICS GUIDE



BLASTMASTER® TORNADO INTERNAL PIPE BLASTING TOOL

Part Numbers	For use in Pipe I.D.	Nozzles
see 10C02601	8"-36"	10AT4 (Quantity of Two)

**Centering Carriages not included*



PART NUMBERS AND SCHEMATICS GUIDE

BLASTMASTER® TORNADO INTERNAL PIPE BLASTING TOOL CENTERING CARRIAGES			
	Part Numbers	<i>For use in Pipe I.D.</i>	Style
	<i>see 10C04971*</i>	12"–36"	Pipe and Wheel
	1084107*	40"–60"	Pipe and Wheel

**Blastmaster® Tornado Internal Pipe Blast Tool not included*

PART NUMBERS AND SCHEMATICS GUIDE

Blastmaster® Tornado Internal Pipe Blasting Tool

Item #	Part #	Description
Fig. 1		
1	1084082	Tube Casting
2		Brake Housing
3	1084089	Locking Pin (<i>Quantity of Two</i>)
4	1084087	Specialty Brake with Lining
5	1084093	Support Ring
6	1084080	Double Seal Light Bearing (<i>Quantity of Two</i>)
7	1084081	Main Body
8		Locking Ring (<i>Quantity of Two</i>)
9	1084094	Felt Seal (<i>Quantity of Two</i>)
10		U Seal (<i>Quantity of Two</i>)
11	1084085	Seal Retainer
12	1084096	Base Assembly (<i>Includes Dowel Pin</i>)
13	—	Dowel Pin
14	1084078	End Locking Nut
15	1084083	Entry Nozzle
16	1084084	Bearing Seal
17	1084097	Wear Sleeve
18	1084098	Spring
19	1084099	Screw (<i>Quantity of Two</i>)
20	1084100	NPT Plug
21	10AT4	#4 Straight Bore Nozzle, Tungsten Carbide Liner, Aluminum Jacket, 1/4" Orifice (<i>Quantity of Two</i>)
—	10AT5	#5 Straight Bore Nozzle, Tungsten Carbide Liner, Aluminum Jacket, 5/16" Orifice
—	10C01410	#5 Tornado Nozzle, 3" Long, 5/16" Orifice
—	10AT6	#6 Straight Bore Nozzle, Tungsten Carbide Liner, Aluminum Jacket, 3/8" Orifice
—	1084092	#6 Tornado Nozzle, 3" Long, 3/8" Orifice
22	1084071	Rotating Nozzle Head
—	1084101	2" Tornado Large Rotating Head Assembly (<i>Optional</i>) (<i>See Fig. 5</i>)
—	10SN450UN	#4 Large Venturi Nozzle, Tungsten Carbide Liner, Poly Jacket, 50mm Threads, 1/4" Orifice (<i>For Use With 1084101 Large Rotating Head Only</i>)
—	10SN550UN	#5 Large Venturi Nozzle, Tungsten Carbide Liner, Poly Jacket, 50mm Threads, 5/16" Orifice (<i>For Use With 1084101 Large Rotating Head Only</i>)
—	10SN650UN	#6 Large Venturi Nozzle, Tungsten Carbide Liner, Poly Jacket, 50mm Threads, 3/8" Orifice (<i>For Use With 1084101 Large Rotating Head Only</i>)
23	1084090	2-1/2" Round Head Screw (<i>Quantity of Four</i>)
24		Flat Washer (<i>Quantity of Eight</i>)
25	1084103	Spring Washer (<i>Quantity of Eight</i>)
26	1084104	Screw (<i>Quantity of Four</i>)
27	1084105	NTC-1 Nylon Threaded Tank Coupling (<i>Quantity of Two</i>)
—	106M614	Part Numbers & Schematics Guide – Blastmaster® Tornado Internal Pipe Blasting Tool
—	1090614	Operator's Manual – Blastmaster® Tornado Internal Pipe Blasting Tool

PART NUMBERS AND SCHEMATICS GUIDE

Figure 1: Blastmaster® Tornado Internal Pipe Blasting Tool

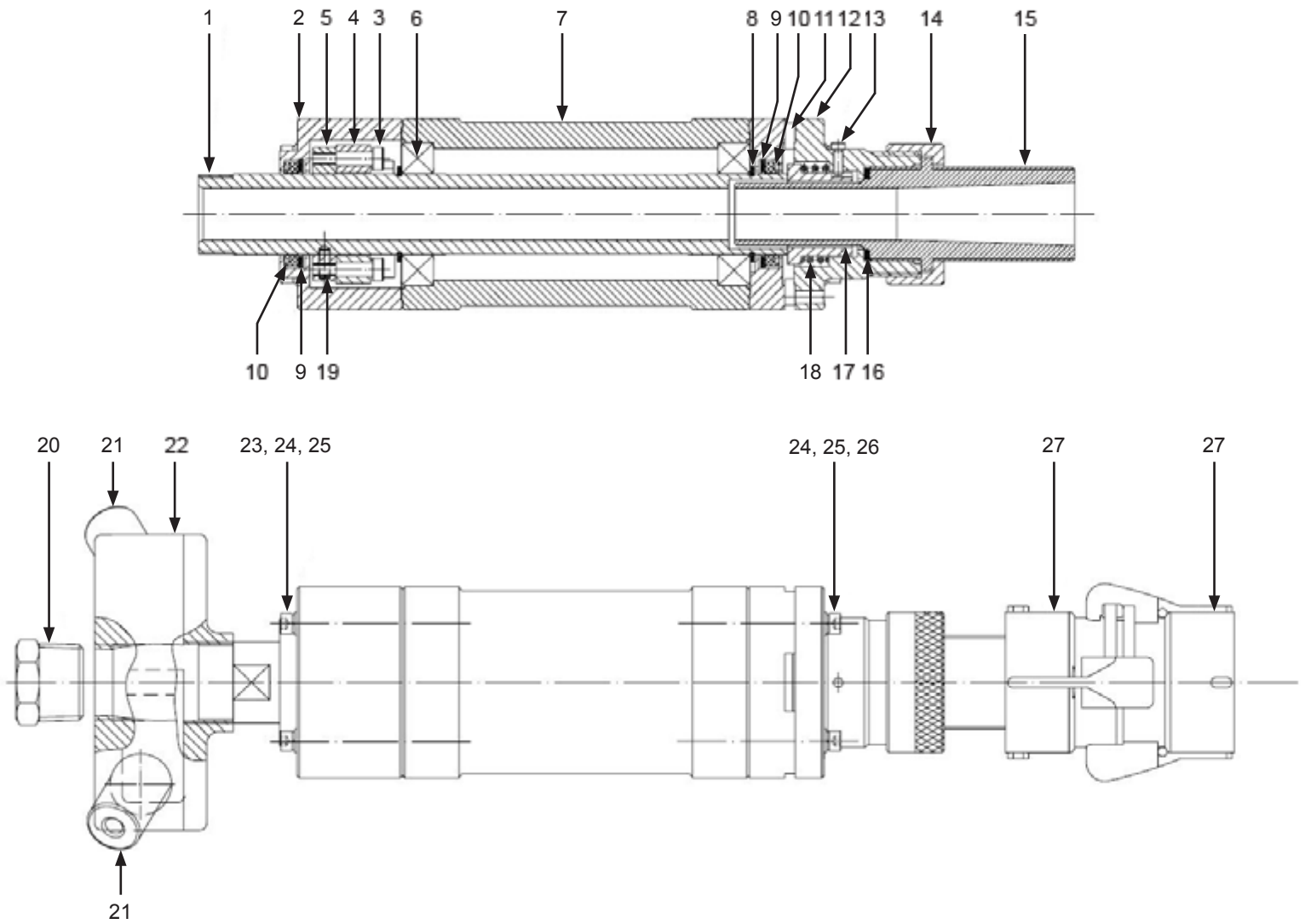

OPTIONAL ACCESSORIES

Figure 2: Tornado Pipe and Wheel Carriage for 12"–36" I.D.

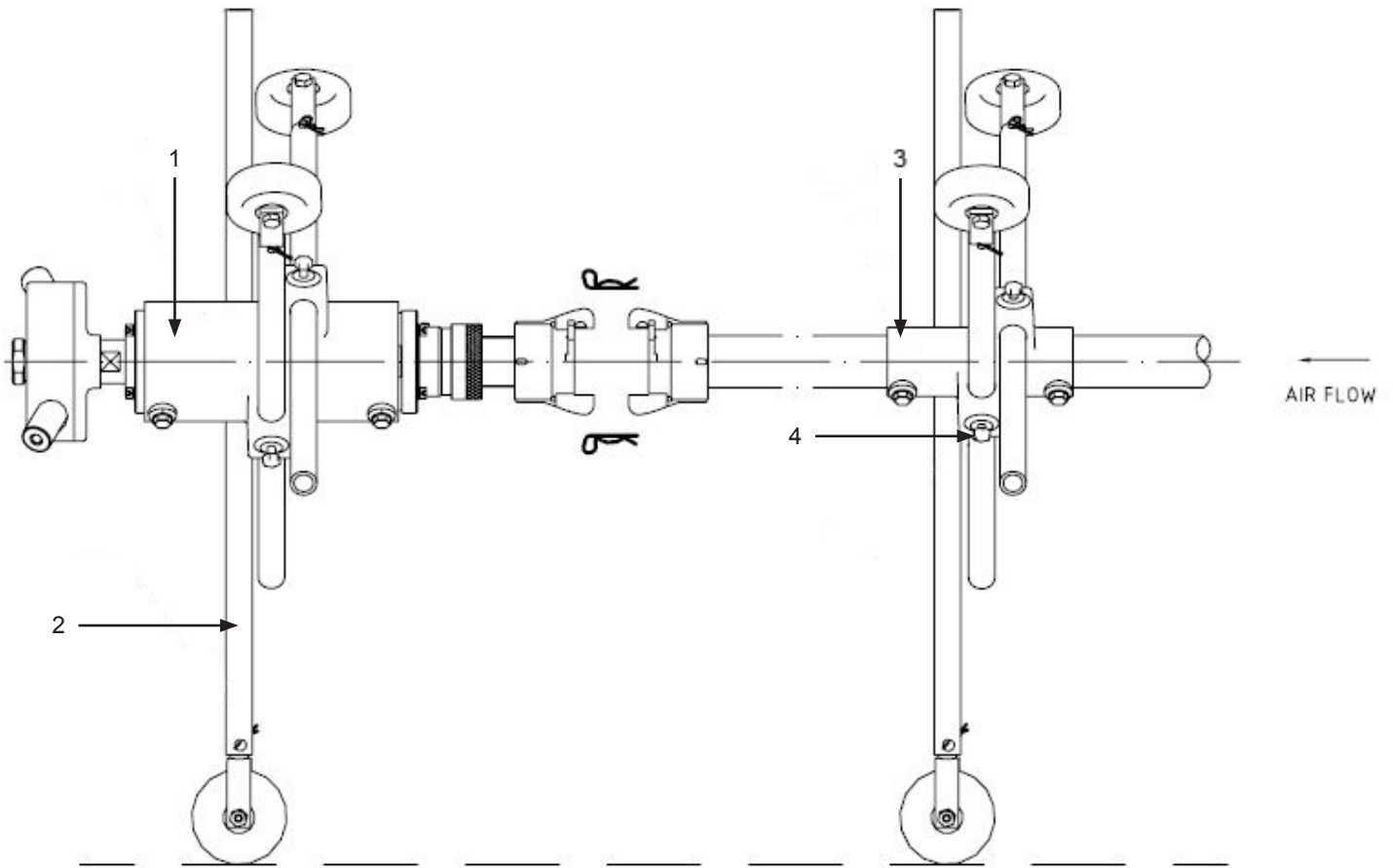

Item#	Part#	Description
-------	-------	-------------

Fig. 2

1		
2	1084074	Medium Leg Set (<i>Includes Leg Extensions, Wheel Brackets, Wheels, and Fittings</i>)
3	10C04938	Rear Body Collar
4	1084106	5/16" x 26mm Machine Screw Hex Head (<i>Quantity of Ten</i>)

OPTIONAL ACCESSORIES

Figure 3: Tornado Pipe and Wheel Carriage for 40"–60" I.D.

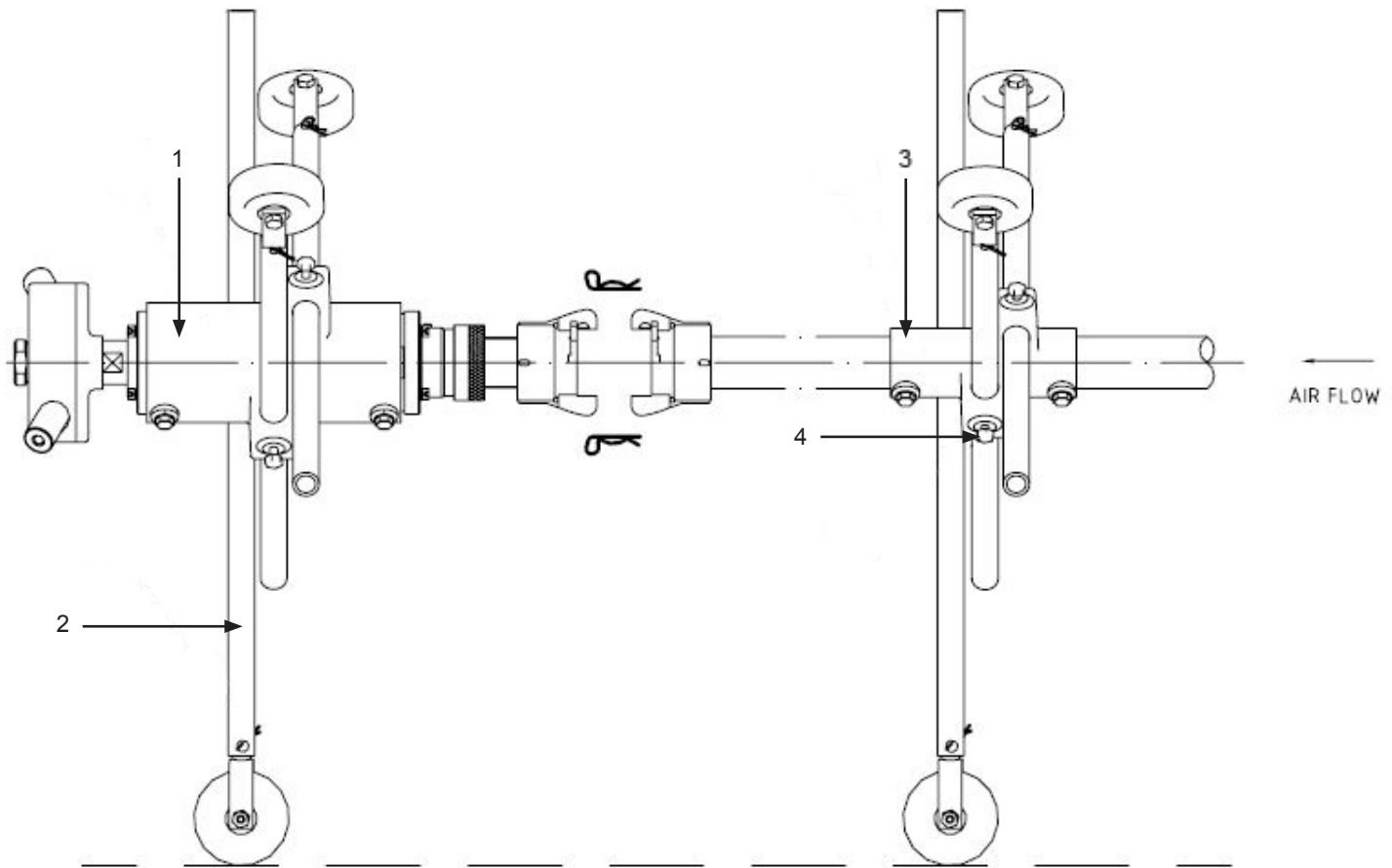

Item#	Part#	Description
-------	-------	-------------

Fig. 3

—	1084107	Tornado Pipe and Wheel Carriage for 40" – 60" I.D. Pipe
---	----------------	--

1	10C04937	Front Body Collar
---	----------	-------------------

2	1084075	Long Leg Set <i>(Includes Leg Extensions, Wheel Brackets, Wheels, and Fittings)</i>
---	---------	---

3	10C04938	Rear Body Collar
---	----------	------------------

4	1084106	5/16" x 26mm Machine Screw Hex Head <i>(Quantity of Ten)</i>
---	---------	--

OPTIONAL ACCESSORIES

Figure 4: 2" Tornado Large Rotating Head Assembly

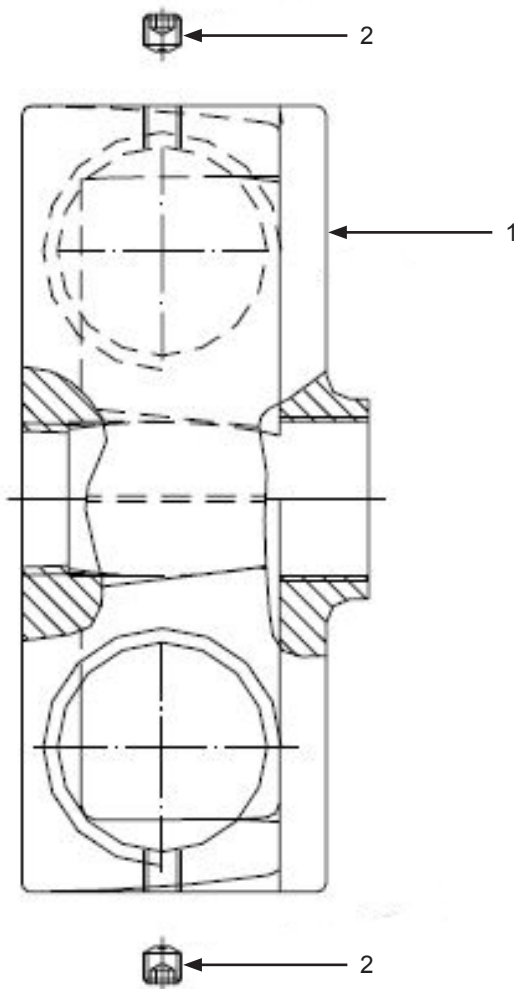

Item#	Part#	Description
Fig. 4		
—	1084101	2" Tornado Large Rotating Head Assembly <i>(For use when blasting 40"–60" pipe)</i>
1	—	50mm 2" Contractor Large Rotating Head
2	—	Screw <i>(Quantity of Two)</i>
—	10SN650UN	Blastmaster® Silicon Carbide All Poly Nozzles – #6, 3/8" Orifice <i>(Two Required) (Optional)</i>

GLOBAL HEADQUARTERS

- 3425 East Locust Street
Davenport, IA 52803

ph: 800.BLAST.IT (800.252.7848)
ph: 563.324.2519
fax: 563.324.6258

REGIONAL BRANCH OFFICES

- **Iowa**
Davenport
- **Louisiana**
Gonzales
Harvey
Lafayette
- **Ohio**
Youngstown
- **Texas**
Beaumont
Corpus Christi
Deer Park

40+ NATIONWIDE SHIPPING LOCATIONS



★ Marco Regional Branch Offices and Shipping Locations ● Direct Shipping Locations



ABRASIVES
BLASTING
COATING
DUST COLLECTORS
ENGINEERED SYSTEMS
RENTAL
SAFETY
SERVICE, REPAIR, & MODERNIZATION
VACUUMS

CONTACT MARCO

800.BLAST.IT
(800.252.7848)
563.324.2519
FAX: 563.324.6258

WWW.MARCO.US
SALES@MARCO.US