



BLASTMASTER® 6.5 CU. FT. S-SERIES ABRASIVE BLASTING POT



BUILT MARCO TOUGH
MARCO MANUFACTURED

PART NUMBERS AND SCHEMATICS GUIDE

Company Profile

Since 1944, Marco has developed a strong tradition of providing innovative and reliable products and services to the surface preparation and protective coatings industries. We are the world's premier provider of Abrasives, Blasting Equipment, Coating Equipment, Engineered Systems, Rental Equipment, Safety Equipment, Service, and Repair.

Through innovative designs and a total commitment to quality, Marco manufactures products that increase production rates, create a safer workplace, and reduce maintenance costs. Marco's industry experience, manufacturing capabilities, legendary customer service, product availability, logistics services, and technology leadership is your assurance that we deliver high quality products and services, providing the best value to you, our customer.

The Marco Difference

- **Industry Experience** – With Marco on your team, you have access to expertise which can only come from decades of industry leadership. We have organized our engineering department, production specialists, customer operations, and safety support into a “Center of Competence.” As a Marco customer, you have access to hundreds of years of cumulative experience related to your operations.
- **Manufacturing Excellence** – Marco is a U.S. based, ISO 9001:2008 certified manufacturer of equipment for the Surface Preparation and Protective Coatings industries. Marco's engineers benchmark the industry to ensure that we design and manufacture superior products that set the “Gold Standard” for performance, safety, and quality.
- **Legendary Customer Service** – Marco's legendary customer service team is staffed by friendly, highly-trained individuals who are focused on providing the highest level of product support, order accuracy, and customer satisfaction.
- **Product Availability** – We stock over 10,000 SKU's and have over 45 shipping locations to serve North American and International markets for all major brands of blasting and painting equipment. As the largest provider of surface preparation and protective coatings equipment in the world, our inventory levels and product availability are unmatched.
- **Logistics Services** – Marco's in-house logistics team is dedicated to moving your shipment anywhere in the world. We move over 14,000 truckloads every year, allowing you to save on freight costs by leveraging our buying power. Lower your process costs with a single invoice, which includes product and freight.
- **Technology Leadership** – Our website provides: Operator's Manuals, Part Numbers and Schematics Guides, MSDS information, and Features and Specifications Guides, providing access to information 24/7. Our Extranet application allows you to receive quotes and place orders online. Our Intranet maintains a complete record of your purchase history to assist with ongoing support of your existing equipment and future purchasing decisions.

Vision Statement

Marco is the world's premier provider of Abrasives, Blasting Equipment, Coating Equipment, Engineered Systems, Rental Equipment, Safety Equipment, Service, and Repair.

Mission Statement

Marco provides strong leadership and innovation to the surface preparation and protective coatings industries. We dedicate our efforts to the continuous improvement of our products, services, processes, people, and most importantly, the quality of our customer's experience.

Quality Statement

Marco is committed to providing superior quality in the design, manufacturing, distribution, rental, service, and repair of our products. Our ISO 9001:2008 certification extends throughout all operations in all locations. Continuous improvement of our processes and supply chain Integration comprise the core of our business strategy for delivering exceptional quality and value in all Marco products and services.

Management Philosophy

We are a company dedicated to the success of every customer and associate. We discuss, debate, challenge, measure, and test our ideas. We will be boundless and limitless in our passion to improve. Through sound leadership and dedicated associates, we will ensure a long term, profitable future for Marco, our associates, customers, and suppliers.

TABLE OF CONTENTS

Company Profile	2
Table of Contents	3
Part Numbers	4
Part Numbers and Schematics	5
Inspection Door Assembly	5
Pop-up Valve Assembly	5
Blastmaster® 6.5 Cu. Ft. S-Series Abrasive Blasting Pot — Pneumatic — 1-1/4”	6
Blastmaster® 6.5 Cu. Ft. S-Series Abrasive Blasting Pot — Pneumatic — 1-1/2”	8
Blastmaster® 6.5 Cu. Ft. S-Series Abrasive Blasting Pot — Electric — 1-1/4”	10
Blastmaster® 6.5 Cu. Ft. S-Series Abrasive Blasting Pot — Electric — 1-1/2”	12
Pusher Line Assembly	14
Exhaust Muffler Assembly	15
Blastmaster® 123P Remote Control System	16
Tandem Remote Control Valve	17
Blastmaster® Bantam Abrasive Metering Valve	18
12-Volt DC 190 Electric Control Assembly	20
12-Volt DC 190 Electric Solenoid	21
12-Volt AC 190 Electric Control Assembly	22
12-Volt AC 190 Electric Solenoid	23
Blastmaster® 120-Volt AC to 12-Volt AC Power Converter	24
Optional Accessories	26
1-1/4” Extractor Abrasive Blasting Pot Moisture Separator	26
Lid and Screen	27
Loading Skid	28

PART NUMBERS

BLASTMASTER® 6.5 CU. FT. S-SERIES ABRASIVE BLASTING POT

Part Numbers	Power Source	Blastmaster® Remote Control System	Blastmaster® Remote Control Switch	Blastmaster® Bantam Abrasive Metering Valve	1-1/4" Extractor Abrasive Blasting Pot Moisture Separator	Loading Skid
1065002	Pneumatic	123P	152P	1-1/4"		
1065002PKA	Pneumatic	123P	152P	1-1/4"	X	
1065002PKALS	Pneumatic	123P	152P	1-1/4"	X	X
1065002LS	Pneumatic	123P	152P	1-1/4"		X
1065003	Pneumatic	123P	152P	1-1/2"		
1065003PKA	Pneumatic	123P	152P	1-1/2"	X	
1065003PKALS	Pneumatic	123P	152P	1-1/2"	X	X
1065003LS	Pneumatic	123P	152P	1-1/2"		X
1065005	12-Volt DC	123E	151E	1-1/4"		
1065005PKA	12-Volt DC	123E	151E	1-1/4"	X	
1065005PKALS	12-Volt DC	123E	151E	1-1/4"	X	X
1065005LS	12-Volt DC	123E	151E	1-1/4"		X
1065006	12-Volt DC	123E	151E	1-1/2"		
1065006PKA	12-Volt DC	123E	151E	1-1/2"	X	
1065006PKALS	12-Volt DC	123E	151E	1-1/2"	X	X
1065006LS	12-Volt DC	123E	151E	1-1/2"		X
1065008	120-Volt AC	123E	151E	1-1/4"		
1065008PKA	120-Volt AC	123E	151E	1-1/4"	X	
1065008PKALS	120-Volt AC	123E	151E	1-1/4"	X	X
1065008LS	120-Volt AC	123E	151E	1-1/4"		X
1065009	120-Volt AC	123E	151E	1-1/2"		
1065009PKA	120-Volt AC	123E	151E	1-1/2"	X	
1065009PKALS	120-Volt AC	123E	151E	1-1/2"	X	X
1065009LS	120-Volt AC	123E	151E	1-1/2"		X

PART NUMBERS AND SCHEMATICS

Figure 1: Inspection Door Assembly

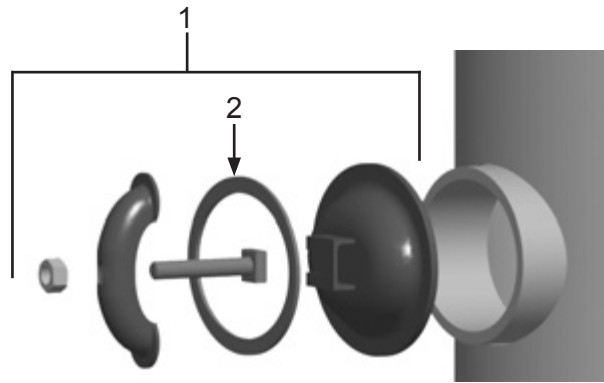

Item #	Part #	Description
Fig. 1		
1	1006200	6" x 8" Inspection Door Assembly
2	1006201	Gasket

Figure 2: Pop-up Valve Assembly

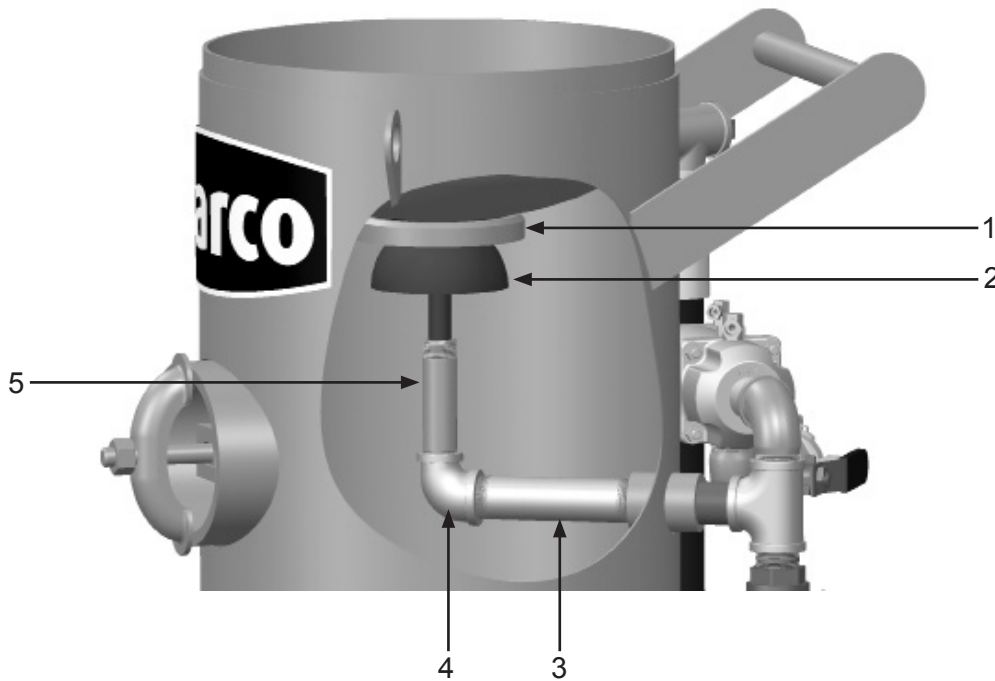

Item #	Part #	Description
Fig. 2		
1	1006040	Pop Up Valve Seat
2	1006030	Pop Up Valve
3	1011214	1-1/4" x 10" NPT Pipe Nipple
4	1006210	1-1/4" x 1" Reducing Pipe Elbow
5	1011815	1" x 5" NPT Pipe Nipple

PART NUMBERS AND SCHEMATICS

Blastmaster® 6.5 Cu. Ft. S-Series Abrasive Blasting Pot — Pneumatic — 1-1/4”

Item #	Part #	Description
Fig. 3		
1	1011204	1-1/4" x 3" Galvanized Close Nipple (<i>Three Required</i>)
2	1011803	1-1/4" Pipe Tee (<i>Two Required</i>)
3	1011902	1-1/4" Galvanized Square Head Pipe Plug
4	1011201	1-1/4" Galvanized Close Nipple (<i>Five Required</i>)
5	10NHA1	3/4" Aluminum Nozzle Holder (<i>Two Required</i>)
6	10BH0342BR	Blastmaster® 3/4" I.D. Heavy-Duty Abrasive Blasting Hose (<i>Per Foot</i>)
7	1012300	Blastmaster® Tandem Valve – Complete
8	10ME3	1-1/4" NPT (F) Air Hose Fitting
9	1011602	1-1/4" NPT Full Port Brass Ball Valve (<i>Two Required</i>)
10	1011802	1-1/4" Galvanized Street Elbow (<i>Two Required</i>)
11	1012157	1-1/4" x 1" Bushing
12	1011100	Blastmaster® Abrasive Blasting Pot Muffler (<i>See Fig. 8</i>)
13	1006205	Wheel Clip for 16" Wheels (<i>Four Required</i>)
14	1006064	16" Wheel (<i>Two Required</i>)
15	10SB2S	1-1/2" NPT Brass Tank Coupling
16	1014101	Blastmaster® 1-1/4" Bantam Abrasive Metering Valve
17	—	1-1/4" Pusher Line Assembly (<i>See Fig. 7</i>)
18	1011216	1-1/4" x 3-1/2" Galvanized Close Nipple
—	1012350	Blowdown Hose Assembly <i>Includes Item #'s: 5 (Quantity of One), and 6 (Quantity of Two Feet)</i>
—	106M054	Part Numbers & Schematics Guide – Blastmaster® 6.5 Cu. Ft. S-Series Abrasive Blasting Pot
—	106M068	Part Numbers & Schematics Guide – Blastmaster® 152P Remote Control Switch
—	1090054	Operator's Manual – Blastmaster® 6.5 Cu. Ft. S-Series Abrasive Blasting Pot
—	1090068	Operator's Manual – Blastmaster® 152P Remote Control Switch

PART NUMBERS AND SCHEMATICS

Figure 3: Blastmaster® 6.5 Cu. Ft. S-Series Abrasive Blasting Pot — Pneumatic — 1-1/4”

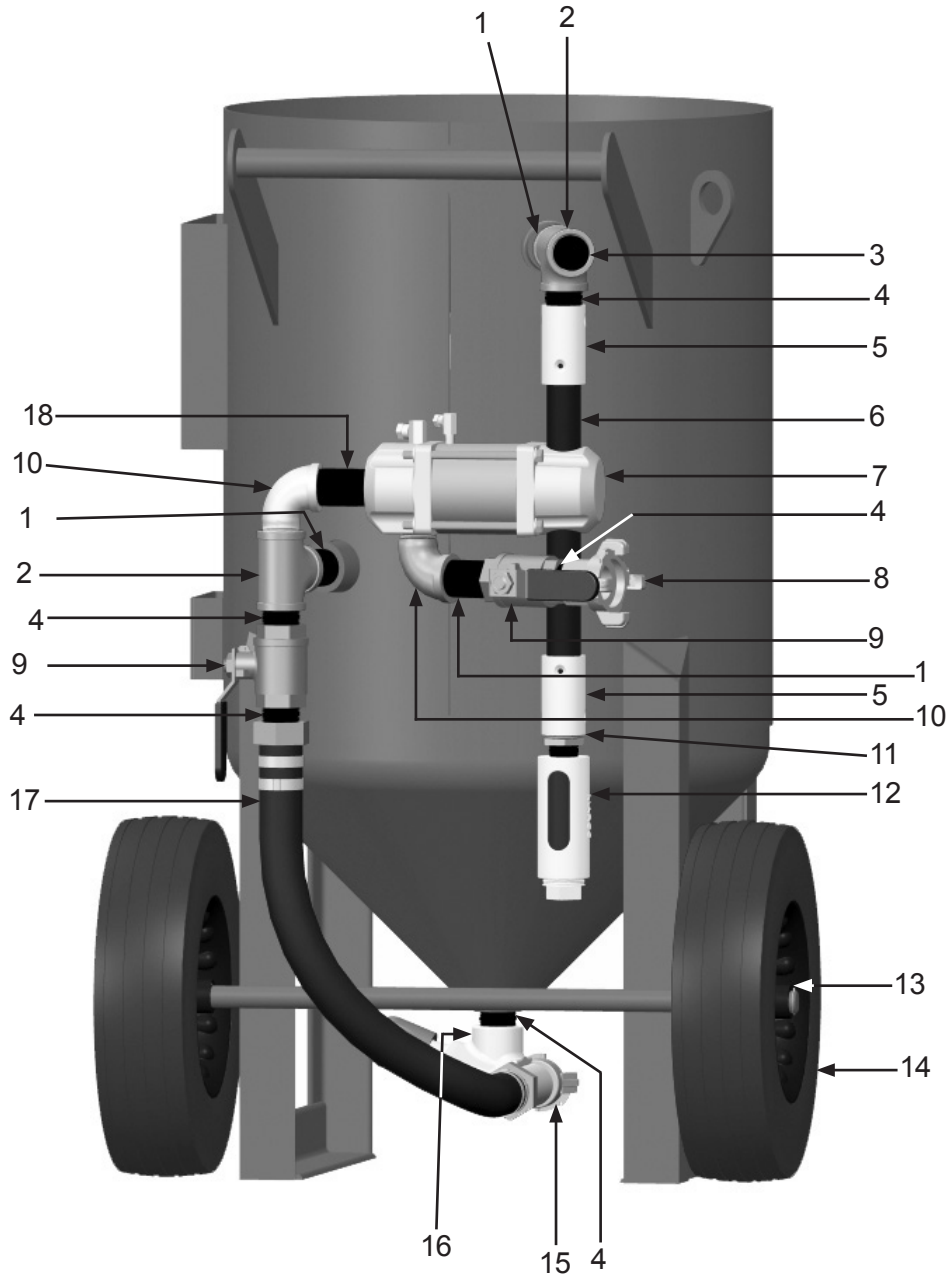

PART NUMBERS AND SCHEMATICS

Blastmaster® 6.5 Cu. Ft. S-Series Abrasive Blasting Pot — Pneumatic — 1-1/2”

Item #	Part #	Description
Fig. 4		
1	1011204	1-1/4" x 3" Galvanized Close Nipple (<i>Three Required</i>)
2	1011803	1-1/4" Pipe Tee
3	1011902	1-1/4" Galvanized Square Head Pipe Plug
4	1011201	1-1/4" Galvanized Close Nipple (<i>Two Required</i>)
5	10NHA1	3/4" Aluminum Nozzle Holder (<i>Two Required</i>)
6	10BH0342BR	Blastmaster® 3/4" I.D. Heavy-Duty Abrasive Blasting Hose (<i>Per Foot</i>)
7	1012300	Blastmaster® Tandem Valve – Complete
8	10ME3	1-1/4" NPT (F) Air Hose Fitting
9	1011602	1-1/4" NPT Full Port Brass Ball Valve (<i>Two Required</i>)
10	1011802	1-1/4" Galvanized Street Elbow (<i>Two Required</i>)
11	1012157	1-1/4" x 1" Bushing
12	1011100	Blastmaster® Abrasive Blasting Pot Muffler (<i>See Fig. 8</i>)
13	1006205	Wheel Clip for 16" Wheels (<i>Four Required</i>)
14	1006064	16" Wheel (<i>Two Required</i>)
15	10SB2S	1-1/2" NPT Brass Tank Coupling
16	1014102	Blastmaster® 1-1/2" Bantam Abrasive Metering Valve
17	—	1-1/2" Pusher Line Assembly (<i>See Fig. 7</i>)
18	1014015	1-1/2" Galvanized Close Nipple (<i>Two Required</i>)
19	1011603	1-1/2" NPT Full Port Brass Ball Valve
20	1011834	1-1/2" x 1-1/4" x 1-1/4" Galvanized Pipe Tee
21	1011216	1-1/4" x 3-1/2" Galvanized Close Nipple
—	1012350	Blowdown Hose Assembly <i>Includes Item #'s: 5 (Quantity of One), and 6 (Quantity of Two Feet)</i>
—	106M054	Part Numbers & Schematics Guide – Blastmaster® 6.5 Cu. Ft. S-Series Abrasive Blasting Pot
—	106M068	Part Numbers & Schematics Guide – Blastmaster® 152P Remote Control Switch
—	1090054	Operator's Manual – Blastmaster® 6.5 Cu. Ft. S-Series Abrasive Blasting Pot
—	1090068	Operator's Manual – Blastmaster® 152P Remote Control Switch

PART NUMBERS AND SCHEMATICS

Figure 4: Blastmaster® 6.5 Cu. Ft. S-Series Abrasive Blasting Pot — Pneumatic — 1-1/2”

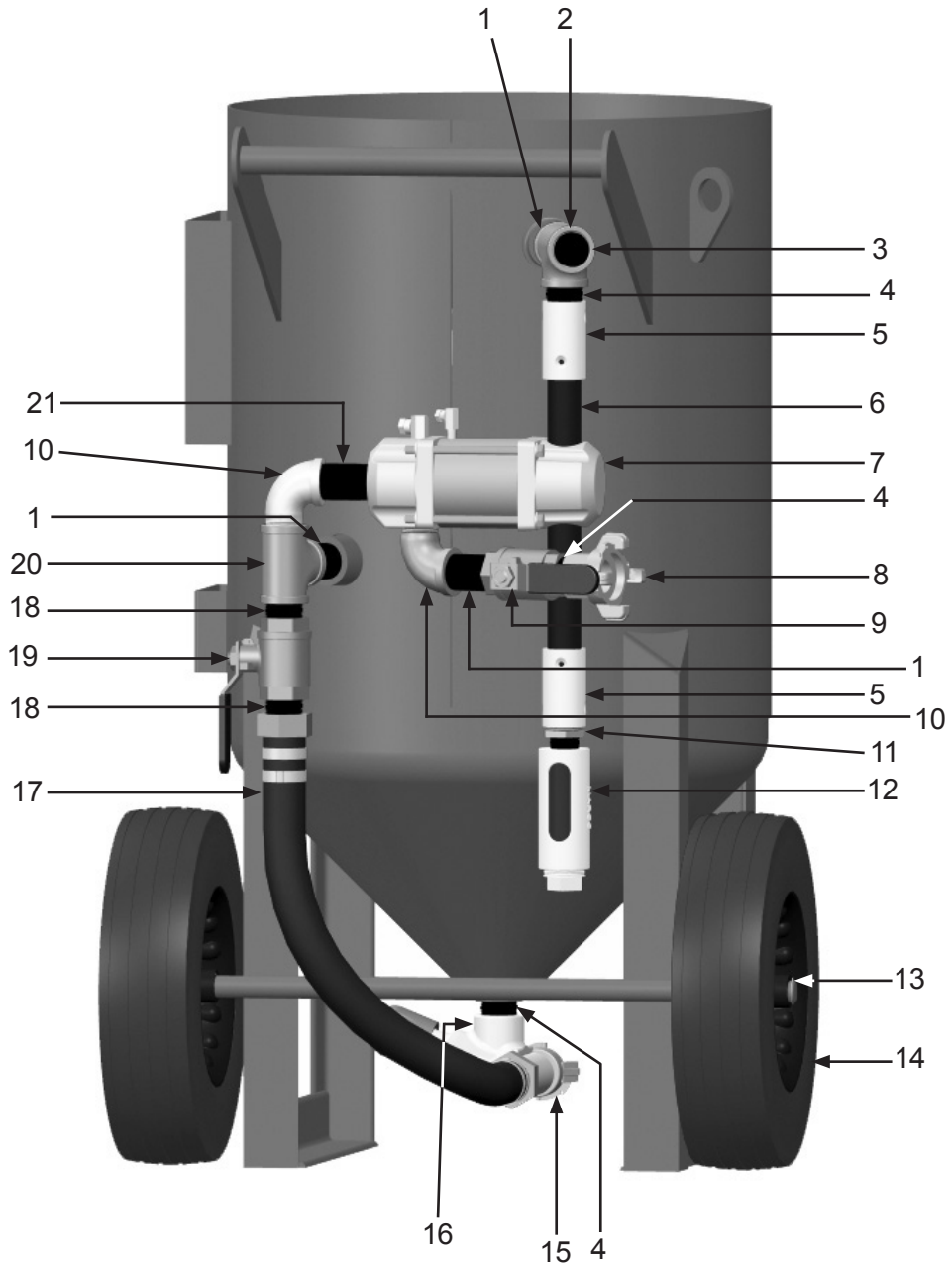

PART NUMBERS AND SCHEMATICS

Blastmaster® 6.5 Cu. Ft. S-Series Abrasive Blasting Pot — Electric — 1-1/4"

Item #	Part #	Description
Fig. 5		
1	1011204	1-1/4" x 3" Galvanized Close Nipple (<i>Three Required</i>)
2	1011803	1-1/4" Pipe Tee (<i>Two Required</i>)
3	1011902	1-1/4" Galvanized Square Head Pipe Plug
4	1011201	1-1/4" Galvanized Close Nipple (<i>Four Required</i>)
5	10NHA1	3/4" Aluminum Nozzle Holder (<i>Two Required</i>)
6	10BH0342BR	Blastmaster® 3/4" I.D. Heavy-Duty Abrasive Blasting Hose (<i>Per Foot</i>)
7	1012300	Blastmaster® Tandem Valve – Complete
8	10ME3	1-1/4" NPT (F) Air Hose Fitting
9	1011602	1-1/4" NPT Full Port Brass Ball Valve (<i>Two Required</i>)
10	1011802	1-1/4" Galvanized Street Elbow (<i>Two Required</i>)
11	1012157	1-1/4" x 1" Bushing (<i>Two Required</i>)
12	1011100	Blastmaster® Abrasive Blasting Pot Muffler (<i>See Fig. 8</i>)
13	1006205	Wheel Clip for 16" Wheels (<i>Four Required</i>)
14	1006064	16" Wheel (<i>Two Required</i>)
15	10SB2S	1-1/2" NPT Brass Tank Coupling
16	1014101	Blastmaster® 1-1/4" Bantam Abrasive Metering Valve
17	—	1-1/4" Pusher Line Assembly (<i>See Fig. 7</i>)
18	1011216	1-1/4" x 3-1/2" Nipple
19	1019051	12-Volt DC 190 Electric Control Assembly
—	1019052	12-Volt AC 190 Electric Control Assembly
—	1012350	Blowdown Hose Assembly <i>Includes Item #'s: 5 (Quantity of One), and 6 (Quantity of Two Feet)</i>
—	106M063	Part Numbers & Schematics Guide – Blastmaster® 156E Remote Control Switch
—	106M054	Part Numbers & Schematics Guide – Blastmaster® 6.5 Cu. Ft. S-Series Abrasive Blasting Pot
—	1090063	Operator's Manual – Blastmaster® 156E Remote Control Switch
—	1090054	Operator's Manual – Blastmaster® 6.5 Cu. Ft. S-Series Abrasive Blasting Pot

PART NUMBERS AND SCHEMATICS

Figure 5: Blastmaster® 6.5 Cu. Ft. S-Series Abrasive Blasting Pot — Electric — 1-1/4”

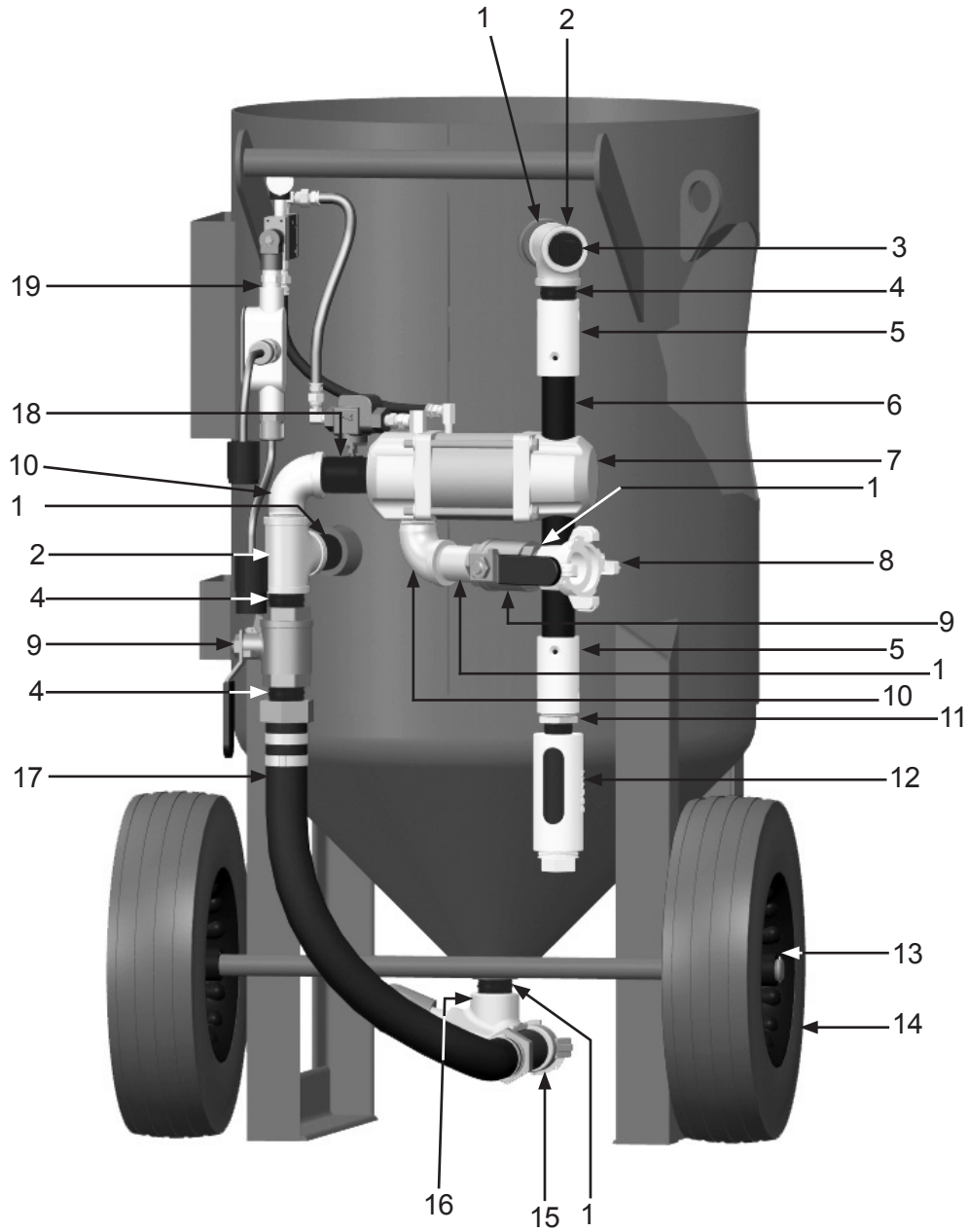

PART NUMBERS AND SCHEMATICS

Blastmaster® 6.5 Cu. Ft. S-Series Abrasive Blasting Pot — Electric — 1-1/2"

Item #	Part #	Description
Fig. 6		
1	1011204	1-1/4" x 3" Galvanized Close Nipple (<i>Three Required</i>)
2	1011803	1-1/4" Pipe Tee
3	1011902	1-1/4" Galvanized Square Head Pipe Plug
4	1011201	1-1/4" Galvanized Close Nipple (<i>Two Required</i>)
5	10NHA1	3/4" Aluminum Nozzle Holder (<i>Two Required</i>)
6	10BH0342BR	Blastmaster® 3/4" I.D. Heavy-Duty Abrasive Blasting Hose (<i>Per Foot</i>)
7	1012300	Blastmaster® Tandem Valve – Complete
8	10ME3	1-1/4" NPT (F) Air Hose Fitting
9	1011602	1-1/4" NPT Full Port Brass Ball Valve
10	1011802	1-1/4" Galvanized Street Elbow (<i>Two Required</i>)
11	1012157	1-1/4" x 1" Bushing
12	1011100	Blastmaster® Abrasive Blasting Pot Muffler (<i>See Fig. 8</i>)
13	1006205	Wheel Clip for 16" Wheels (<i>Four Required</i>)
14	1006064	16" Wheel (<i>Two Required</i>)
15	10SB2S	1-1/2" NPT Brass Tank Coupling
16	1014102	Blastmaster® 1-1/2" Bantam Abrasive Metering Valve
17	—	1-1/2" Pusher Line Assembly (<i>See Fig. 7</i>)
18	1014015	1-1/2" Galvanized Close Nipple (<i>Two Required</i>)
19	1011603	1-1/2" NPT Full Port Brass Ball Valve
20	1011834	1-1/2" x 1-1/4" x 1-1/4" Galvanized Pipe Tee
21	1011216	1-1/4" x 3-1/2" Galvanized Close Nipple
22	1019051	12-Volt DC 190 Electric Control Assembly
—	1019052	12-Volt AC 190 Electric Control Assembly
—	1012350	Blowdown Hose Assembly <i>Includes Item #'s: 5 (Quantity of One), and 6 (Quantity of Two Feet)</i>
—	106M063	Part Numbers & Schematics Guide – Blastmaster® 156E Remote Control Switch
—	106M054	Part Numbers & Schematics Guide – Blastmaster® 6.5 Cu. Ft. S-Series Abrasive Blasting Pot
—	1090063	Operator's Manual – Blastmaster® 156E Remote Control Switch
—	1090054	Operator's Manual – Blastmaster® 6.5 Cu. Ft. S-Series Abrasive Blasting Pot

PART NUMBERS AND SCHEMATICS

Figure 6: Blastmaster® 6.5 Cu. Ft. S-Series Abrasive Blasting Pot — Electric — 1-1/2”

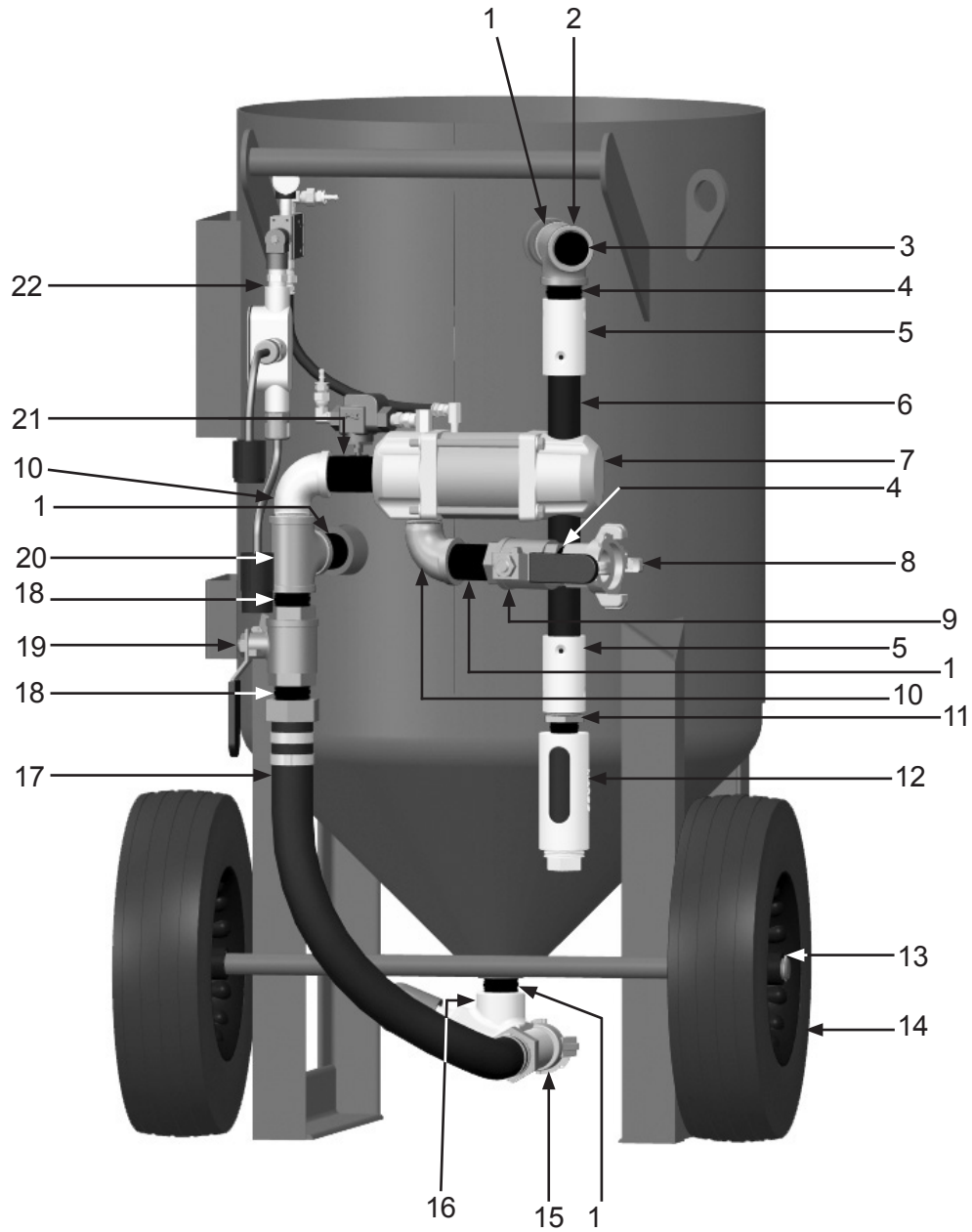

PART NUMBERS AND SCHEMATICS

Figure 7: Pusher Line Assembly

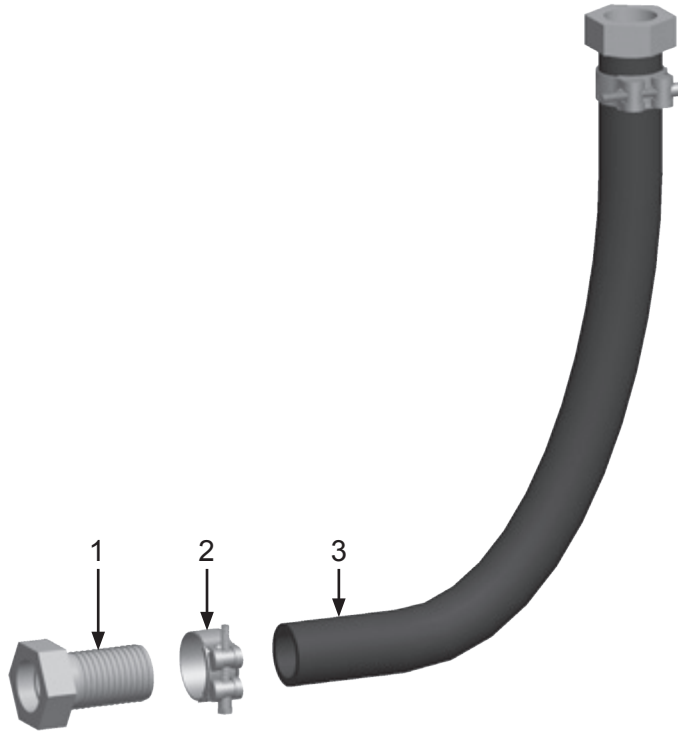

Item #	Part #	Description
Fig. 7		
—	1006311	1-1/4" I.D. Pusher Line Assembly <i>Includes Item #: 1, 2, and 3 (Quantity of Three Feet)</i>
—	1006312	1-1/2" I.D. Pusher Line Assembly <i>Includes Item #: 1, 2, and 3 (Quantity of Three Feet)</i>
1	10SFE3 10SFE4	1-1/4" Female Swivel Air Hose End <i>(Two Required)</i> 1-1/2" Female Swivel Air Hose End <i>(Two Required)</i>
2	10103737 10103738	1-1/4" T-Bolt Hose Clamp <i>(Two Required)</i> 1-1/2" T-Bolt Hose Clamp <i>(Two Required)</i>
3	10AH114B 10AH112B	1-1/4" I.D. Air Hose 1-1/2" I.D. Air Hose
—	10SFE3G	Gasket for 10SFE3 Swivel Air Hose End <i>(Not Shown)</i>
—	10SFE4G	Gasket for 10SFE4 Swivel Air Hose End <i>(Not Shown)</i>
—	1090059	Technical Data Sheet – Pusher Line Assemblies

PART NUMBERS AND SCHEMATICS

Figure 8: Exhaust Muffler Assembly

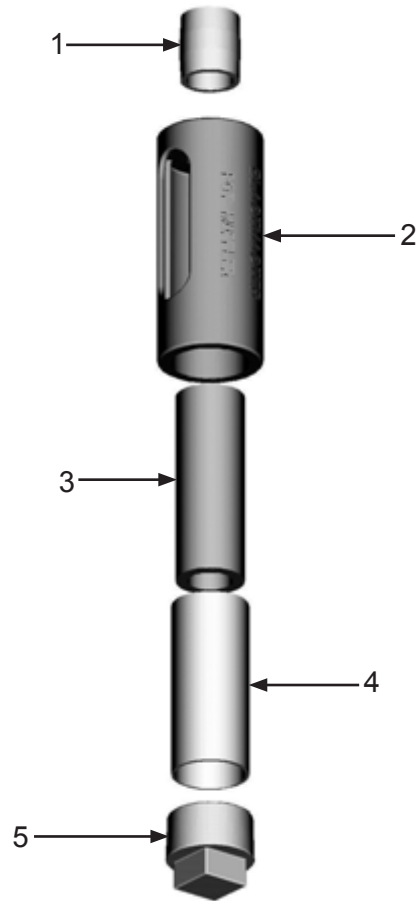

Item #	Part #	Description
Fig. 8		
—	1011100	Blastmaster® Abrasive Blasting Pot Muffler – Complete
1	1012151	1" Close Nipple
2	1011102	Body
3	1011103	Filter Element
4	1011104	Screen
5	1011101	1-1/2" Pipe Plug
—	1011105	Blastmaster® Abrasive Blasting Pot Muffler Service Kit <i>Includes Item #'s: 3 (Quantity of Three), 4, and 5</i>
—	106M347	Part Numbers And Schematics Guide – Blastmaster® Abrasive Blasting Pot Mufflers

PART NUMBERS AND SCHEMATICS

Figure 9: Blastmaster® 123P Remote Control System

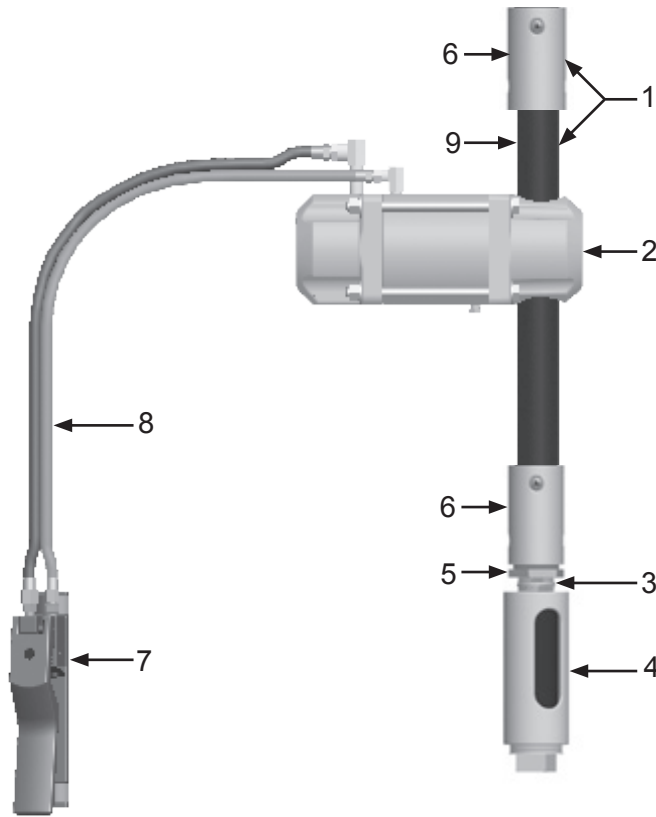

Item #	Part #	Description
Fig. 9		
—	1012351	Blastmaster® 123P Remote Control System – Complete
1	1012350	Blowdown Hose Assembly <i>(Includes Item #'s: 6 and 9 (Quantity of Two Feet))</i>
2	1012300	Tandem Remote Control Valve – Complete
3	1012151	1" Close Nipple
4	1011100	Blastmaster® Exhaust Muffler <i>(See Figure 10)</i>
5	1012157	1-1/4" x 1" Bushing
6	10NHA1	1-1/4" Aluminum Nozzle Holder
7	1015200	Blastmaster® 152P Remote Control Switch
8	1016000	55 Feet of Coupled Control Line with 1/4" and 1/8" Fittings
9	10BH0342BR	3/4" I.D. Abrasive Blasting Hose <i>(sold per foot)</i>
—	106M007	Part Numbers & Schematics Guide – Blastmaster® 123P Remote Control System
—	106M068	Part Numbers & Schematics Guide – Blastmaster® 152P Remote Control Switch
—	1090007	Operator's Manual – Blastmaster® 123P Remote Control System
—	1090068	Operator's Manual – Blastmaster® 152 Remote Control Switch

PART NUMBERS AND SCHEMATICS

Figure 10: Tandem Remote Control Valve

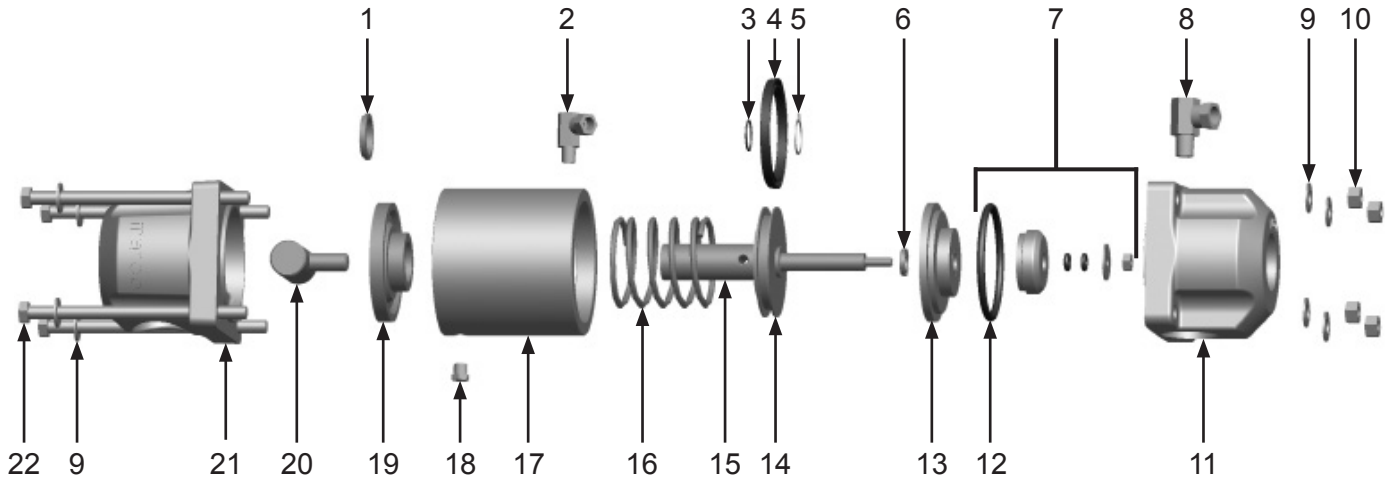

Item #	Part #	Description
Fig. 10		
—	1012300	Tandem Remote Control Valve – Complete
1	1012308	Seal – Upper Rod Guide
2	1014239	1/8" 90° Swivel Fitting
3	1012312	O-ring – Shaft
4	1012317	Seal – Piston
5	1012313	13/16" External Snap Ring
6	1012314	Seal – Lower Rod Guide
7	1012322	Valve Plug Assembly <i>(Includes Item #12)</i>
8	1012326	1/4" 90° Swivel Fitting
9	1014241	3/8" Washer <i>(Eight Required)</i>
10	1012318	3/8-16 Nut <i>(Four Required)</i>
11	1012321	Base
12	1012320	O-ring – Lower Rod Guide
13	1012319	Lower Rod Guide
14	1012315	Piston
15	1012316	Shaft
16	1012309	Spring
17	1012311	Cylinder
18	1012905	1/8" Breather Muffler
19	1012307	Upper Rod Guide
20	1012306	Pinch Ram
21	1012305	Cap
22	1012310	3/8-16 x 6" Bolt <i>(Four Required)</i>
—	1012301	Tandem Remote Control Valve Repair Kit <i>(Includes Item #'s: 1,3–7, and 12)</i>
—	106M007	Part Numbers & Schematics Guide – Blastmaster® 123P Remote Control System
—	1090007	Operator's Manual – Blastmaster® 123P Remote Control System
—	1091045	Hazard Identification Tag

PART NUMBERS AND SCHEMATICS

Blastmaster® Bantam Abrasive Metering Valve

Item #	Part #	
Fig. 11		
—	1014103	1" Female x 1" Female Blastmaster® Bantam Abrasive Metering Valve – Complete <i>(For use with 1/2" I.D. Abrasive Blasting Hose)</i>
—	1014100	1" Blastmaster® Bantam Abrasive Metering Valve – Complete
—	1014101	1-1/4" Blastmaster® Bantam Abrasive Metering Valve – Complete
—	1014102	1-1/2" Blastmaster® Bantam Abrasive Metering Valve – Complete
1	1014110	Metering Knob
2	1014112	5/16-18 x 3-1/4" Hex Bolt <i>(Two Required)</i>
3	1014111	Knob Pin
4	10L805003	5/16" Washer <i>(Two Required)</i>
5	1014113	Cap
6	1014114	Plunger
7	1014115	Valve Body
8	1014219	Plunger Seal
9	1014117	Urethane Sleeve
10	1014118	Gasket
11a	10000135	1" Female x 1" Female Nipple
11b	1014119	1" Female x 1-1/2" Male Nipple
11c	1014120	1-1/4" Male x 1-1/2" Male Nipple
11d	1014121	1-1/2" Male x 1-1/2" Male Nipple
—	1014123	Repair Kit <i>(Includes Item #'s: 2,6,8,9, and 10)</i>
—	1014116	Soft Seal Kit <i>(Includes Item #'s: 8, 9, and 10)</i>
—	1011812	1" Male x 1/2" Female NPT Bushing <i>(For use with 1014103)</i>
—	10SB2S	1-1/2" NPS Brass Tank Coupling <i>(For use with 1014100, 1014101, 1014102)</i>
—	106M022	Part Numbers and Schematics Guide – Blastmaster® Bantam Abrasive Metering Valve
—	1090022	Operator's Manual – Blastmaster® Bantam Abrasive Metering Valve
—	1091045	Warning Tag

PART NUMBERS AND SCHEMATICS

Figure 11: Blastmaster® Bantam Abrasive Metering Valve

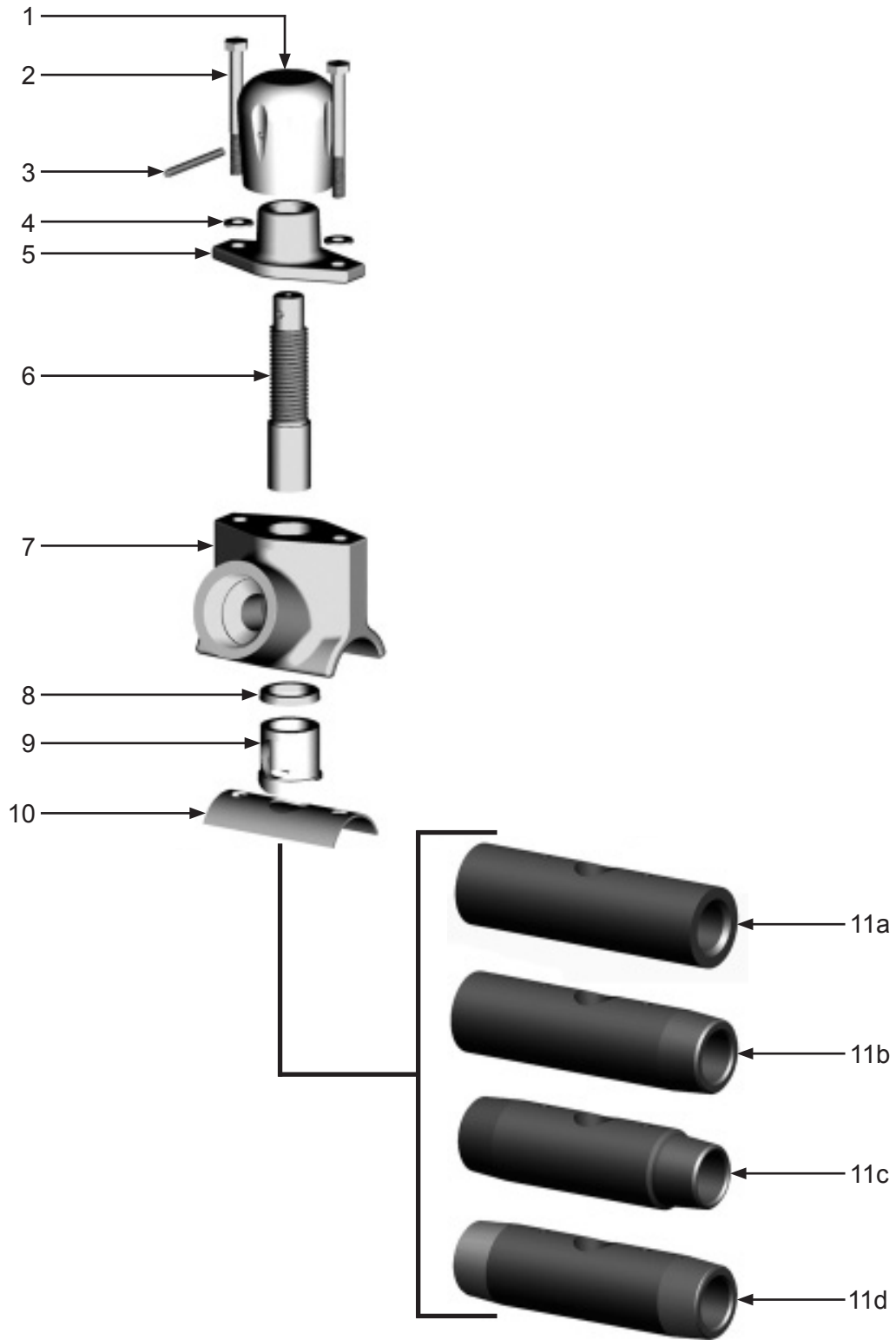

PART NUMBERS AND SCHEMATICS

Figure 12: 12-Volt DC 190 Electric Control Assembly

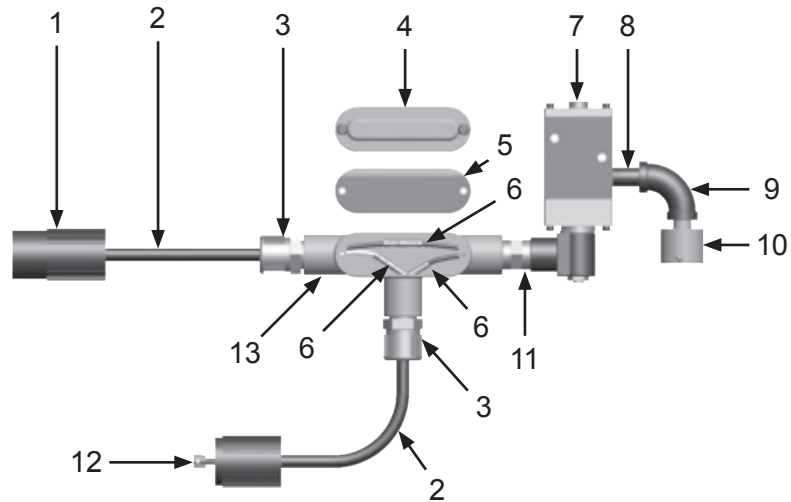

Item #	Part #	Description
--------	--------	-------------

Fig. 12

—	1019051	12-Volt DC 190 Electric Control Assembly – Complete
1	1015556	3-Prong Twist-Lock Plug – Female
2	1015540	16/2 SJ Power Cord – Per Foot
3	1019021	Cord Grip (<i>Two Required</i>)
4	1019022	Conduit Box Cover
5	1019023	Conduit Box Cover Gasket
6	1030028	Butt Splicer (<i>Four Required</i>)
7	1019010	12-Volt DC Electric Solenoid – Complete
8	1011217	1/4" x 2" Pipe Nipple
9	1011832	1/4" NPT 90° Pipe Nipple
10	10DE025	Dust Eliminator
11	20100677	1/2" x 1/2" NPT Hex Nipple
12	1015555	3-Prong Twist-Lock Plug – Male
13	1019020	1/2" Tee Conduit Box

PART NUMBERS AND SCHEMATICS

Figure 13: 12-Volt DC 190 Electric Solenoid

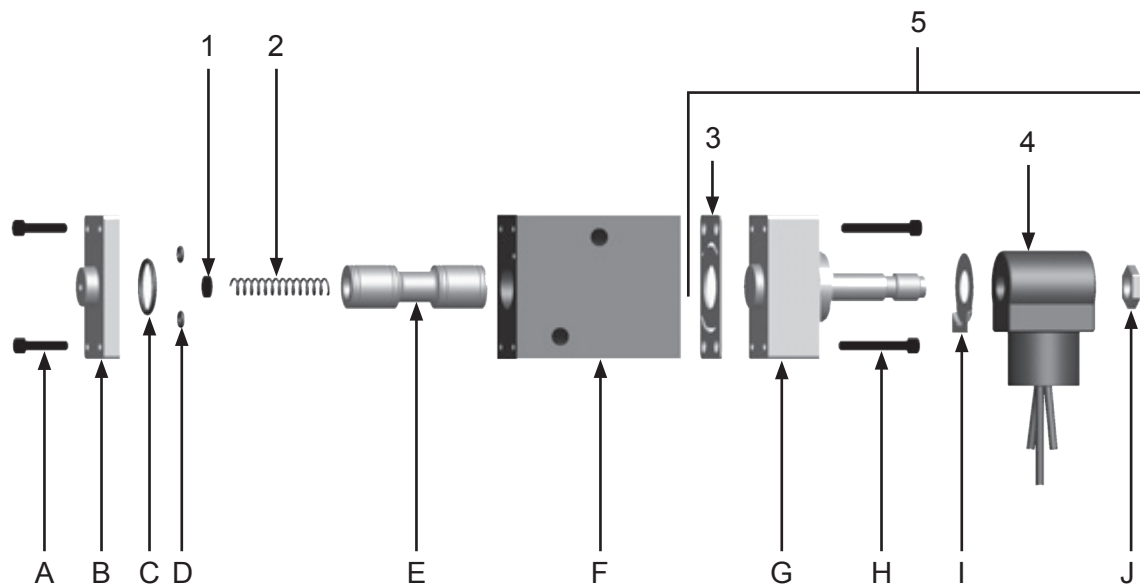

Item #	Part #	Description
--------	--------	-------------

Fig. 13

—	1019010	12-Volt DC 190 Electric Solenoid — Normally-closed — Complete
---	----------------	--

1	1019029	Felt Filter
---	---------	-------------

2	1019032	Spring
---	---------	--------

3	1019033	Gasket
---	---------	--------

4	1019039	12-Volt DC Coil
---	---------	-----------------

5	1019034	12-Volt DC Operator Assembly (Includes Items: #3, #4, G, H, I, and J)
---	---------	--

—	1019030	Electric Solenoid Repair Kit (Includes Items: #1, #2, #3, C, D, and E)
---	---------	---

* Items A–J are not available individually

PART NUMBERS AND SCHEMATICS

Figure 14: 12-Volt AC 190 Electric Control Assembly

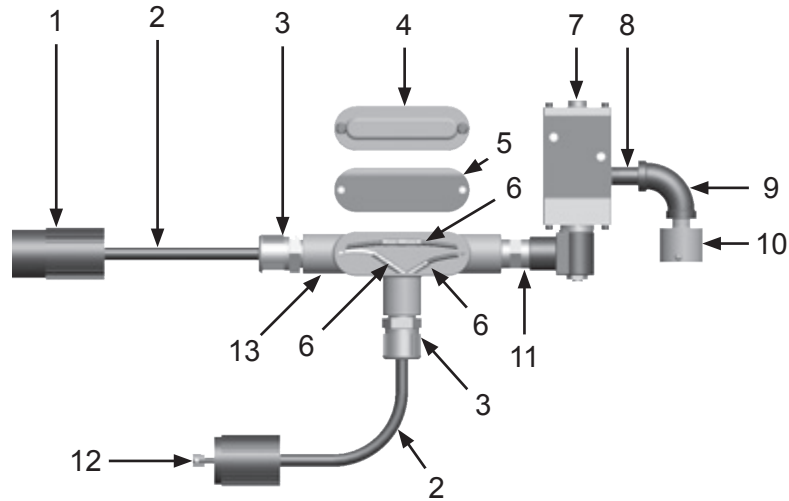

Item #	Part #	Description
--------	--------	-------------

Fig. 14

—	1019052	12-Volt AC 190 Electric Control Assembly – Complete
1	1015556	3-Prong Twist-Lock Plug – Female
2	1015540	16/2 SJ Power Cord – Per Foot
3	1019021	Cord Grip (<i>Two Required</i>)
4	1019022	Conduit Box Cover
5	1019023	Conduit Box Cover Gasket
6	1030028	Butt Splicer (<i>Four Required</i>)
7	1019011	12-Volt AC Electric Solenoid – Complete
8	1011217	1/4" x 2" Pipe Nipple
9	1011832	1/4" NPT 90° Pipe Nipple
10	10DE025	Dust Eliminator
11	20100677	1/2" x 1/2" NPT Hex Nipple
12	1015555	3-Prong Twist-Lock Plug – Male
13	1019020	1/2" Tee Conduit Box

PART NUMBERS AND SCHEMATICS

Figure 15: 12-Volt AC 190 Electric Solenoid

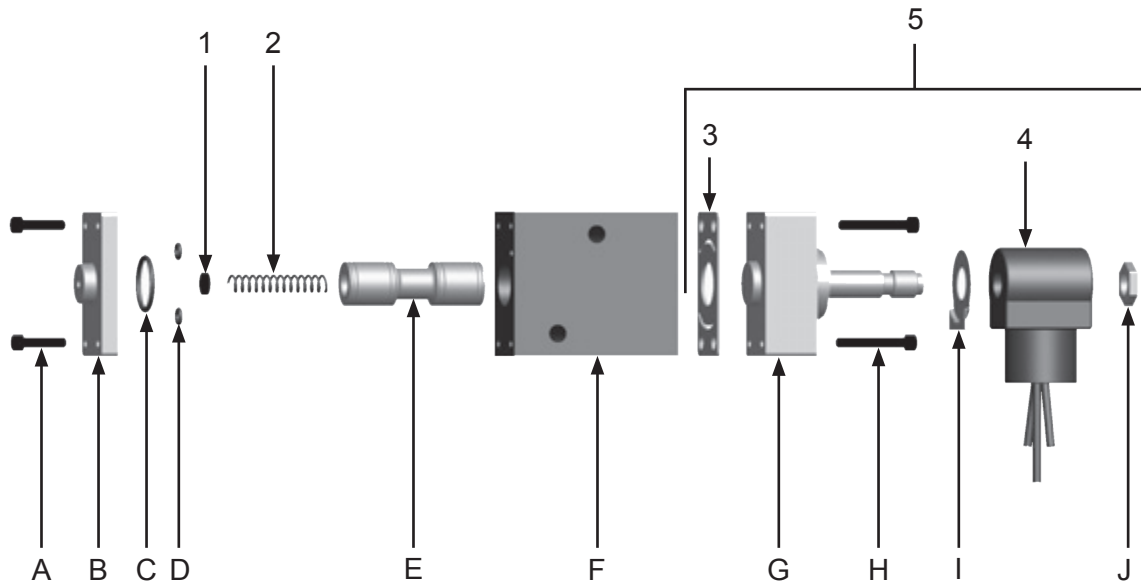

Item #	Part #	Description
Fig. 15		
—	1019011	12-Volt AC 190 Electric Solenoid – Complete
1	1019029	Felt Filter
2	1019032	Spring
3	1019033	Gasket
4	1019040	12-Volt AC Coil
5	1019035	12-Volt AC Electric Operator Assembly (Includes Items: #3, #4, G, H, I, and J)
—	1019030	12-Volt AC Electric Solenoid Repair Kit (Includes Items: #1, #2, #3, C, D, and E)
* Items A–J are not available individually		

PART NUMBERS AND SCHEMATICS

Blastmaster® 120-Volt AC to 12-Volt AC Power Converter

Item #	Part #	Description
Fig. 16		
—	1030020	Blastmaster® 120-Volt AC to 12-Volt AC Power Converter with 3 feet of 14/2 Electric Cord and Plug – Complete
1	1030123	3 Amp Fuse
2	1030023	In-Line Fuse Holder
3	1030022	Transformer – Blastmaster 120-Volt AC to 12-Volt AC Power Converter
4	1091067	Power-Out Decal (<i>Not Shown</i>)
5	1030013	14/2 SEOW Electric Cord (<i>Per Foot</i>)
6	1030025	Strain Relief (<i>Two Required</i>)
7	1030021	Resistor
8	1030026	3-prong, 120-Volt AC Plug – Male
9	1092014	Power-In Decal (<i>Not Shown</i>)
10	1015550	14/3 SEOW Electric Cord (<i>Per Foot</i>)
—	1091063	Hazard Identification Decal

PART NUMBERS AND SCHEMATICS

Figure 16: Blastmaster® 120-Volt AC to 12-Volt AC Power Converter

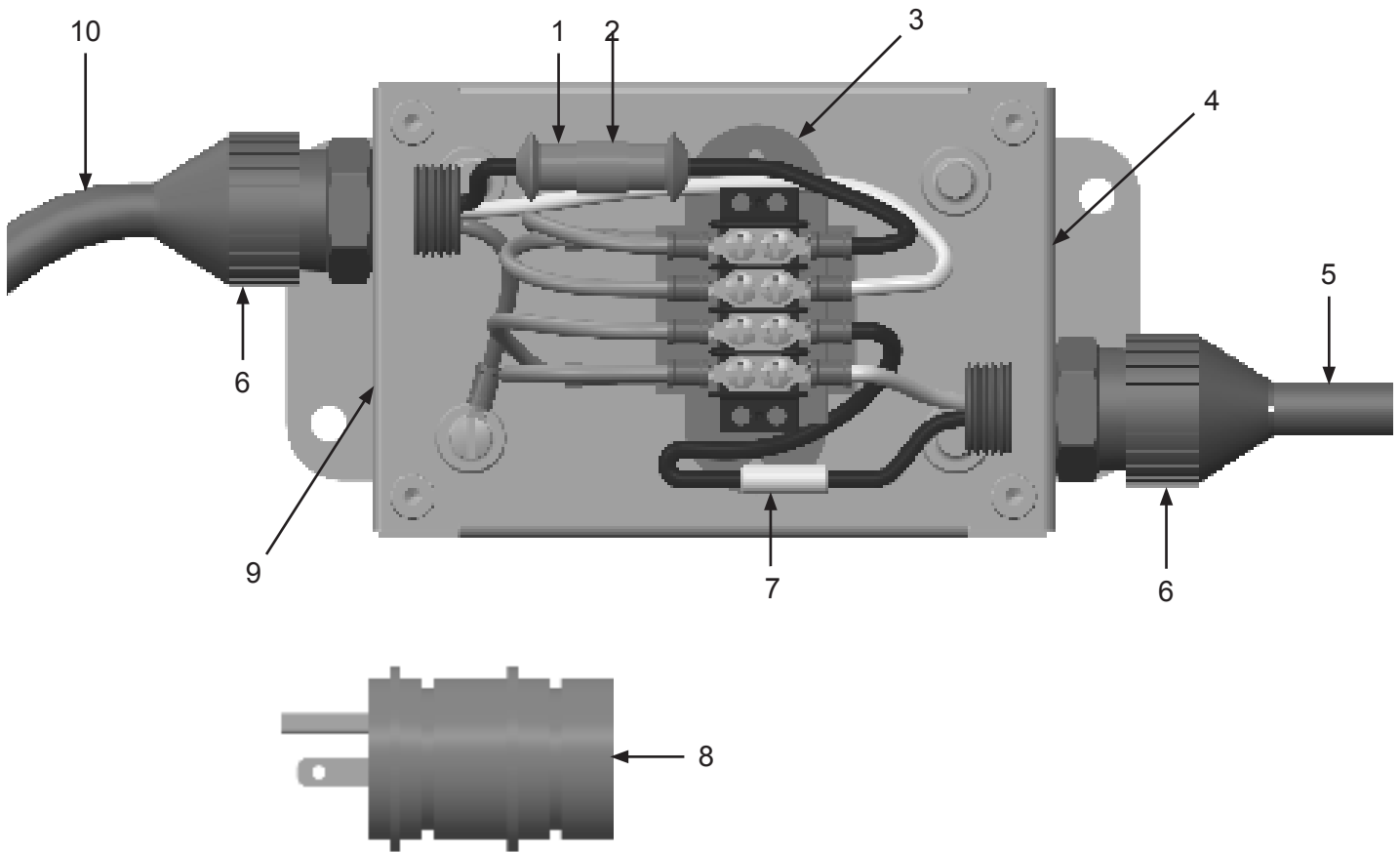

OPTIONAL ACCESSORIES

Figure 17: 1-1/4" Extractor Abrasive Blasting Pot Moisture Separator

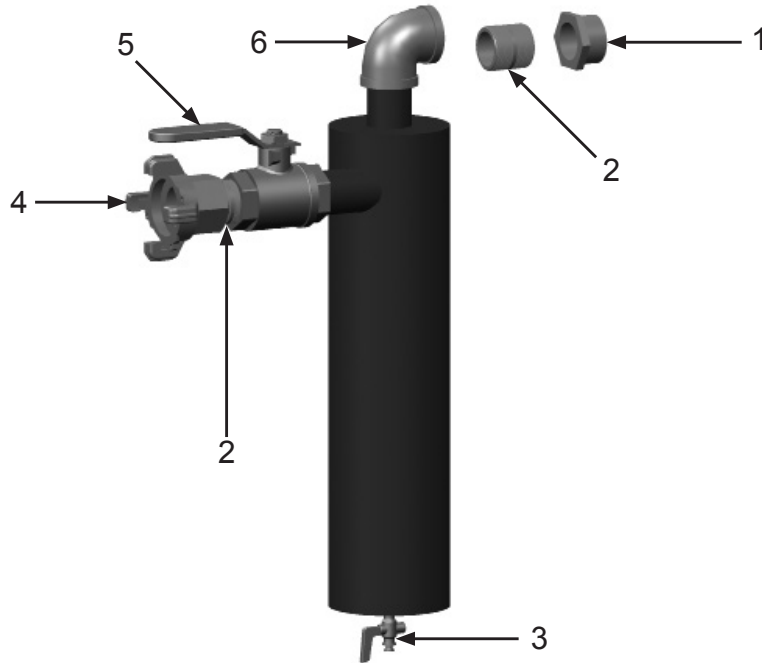

Item #	Part #	Description
Fig. 17		
—	1011740	Blastmaster® 1-1/4" Extractor Moisture Separator
1	1011501	1-1/2" x 1-1/4" Bushing
2	1011201	1-1/4" NPT Close Nipple (<i>Two Required</i>)
3	1012101	1/4" NPT Brass Petcock
4	10ME3	4-Lug Air Hose Fitting – 1-1/4" NPT (F)
5	1011602	1-1/4" NPT Full Port Brass Ball Valve
6	1006204	1-1/4" NPT 90° Elbow
—	106M349	Part Numbers and Schematics Guide – Blastmaster® Extractor Moisture Separators

OPTIONAL ACCESSORIES

Figure 18: Lid and Screen

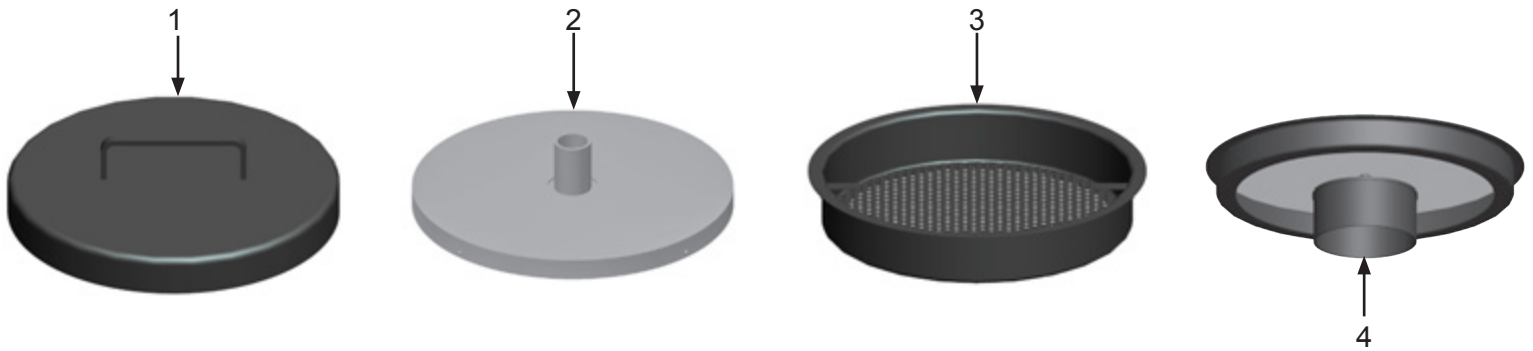

Item #	Part #	Description
Fig. 18		
1	1006101	24" Lid
2	10108827	24" Cover with 2-3/4" Fill
3	1006102	24" Screen
4	10100733	Abrasive Umbrella (<i>Screen Not Included</i>)

OPTIONAL ACCESSORIES

Figure 19: Loading Skid

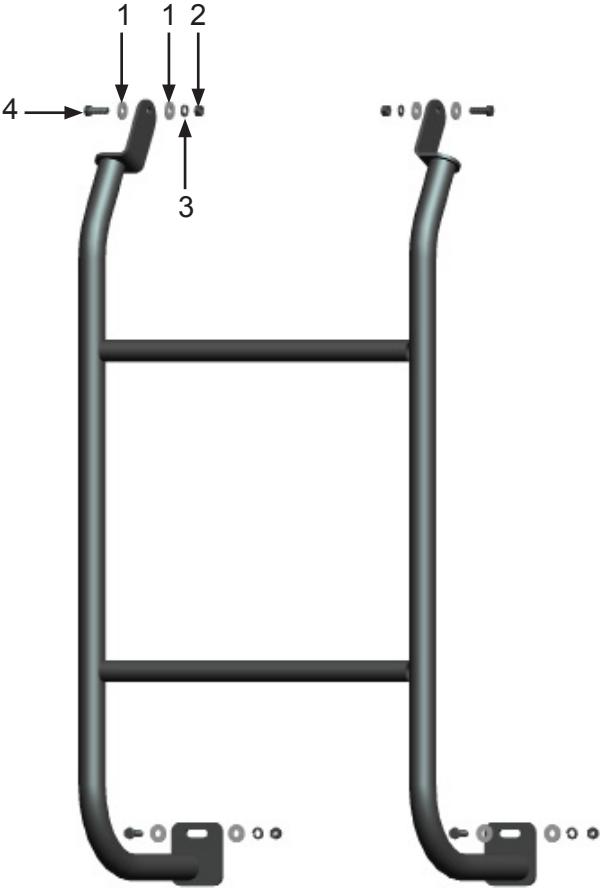

Item #	Part #	Description
Fig. 19		
—	1065040	Load Skid – Complete
1	10L805003	5/16" Zinc Flat Washer
2	1035046	5/16-18 Nut
3	10L805014	5/16" Lock Washer
4	1035045	5/16-18 x 1" Bolt

CONTACT CENTER

- 3425 East Locust Street
Davenport, IA 52803

ph: 800.BLAST.IT (800.252.7848)
ph: 563.324.2519
fax: 563.324.6258

REGIONAL BRANCH OFFICES

- **Iowa**
Davenport
- **Louisiana**
Gonzales
Lafayette
- **Ohio**
Youngstown
- **Texas**
Beaumont
Corpus Christi
Deer Park



ABRASIVES

BLASTING

COATING

DUST COLLECTORS

ENGINEERED SYSTEMS

RENTAL

SAFETY

SERVICE & REPAIR

VACUUMS

40+ NATIONWIDE SHIPPING LOCATIONS



★ Marco Regional Branch Offices
and Shipping Locations

● Direct Shipping Locations

CONTACT MARCO

800.BLAST.IT
(800.252.7848)
563.324.2519
FAX: 563.324.6258

WWW.MARCO.US
SALES@MARCO.US