

# OPERATOR'S MANUAL

## BLASTMASTER® 157E REMOTE CONTROL SWITCH

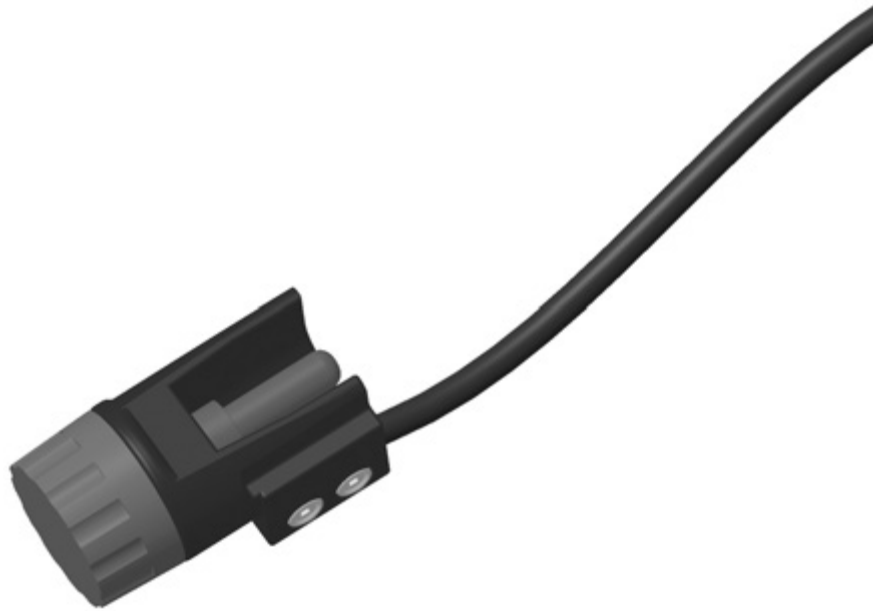

**BUILT MARCO  
TOUGH**  
MARCO MANUFACTURED

### **⚠ WARNING**

Before using this equipment, read, understand and follow all instructions in the Operator's Manuals provided with this equipment. If the user and/or assistants cannot read or understand the warnings and instructions, the employer of the user and/or assistants must provide adequate and necessary training to ensure proper operation and compliance with all safety procedures pertaining to this equipment. If Operator's Manuals have been lost, please visit [www.marco.us](http://www.marco.us), or contact Marco at 563.324.2519 for replacements. Failure to comply with the above warning could result in death or serious injury.

**Marco**

## Company Profile

Since 1944, Marco has developed a strong tradition of providing innovative and reliable products and services to the surface preparation and protective coatings industries. We are the world's premier provider of Abrasives, Blasting, Coating, Dust Collectors, Engineered Systems, Rental, Safety, Service, Repair, & Modernization, and Vacuums.

Through innovative designs and a total commitment to quality, Marco manufactures products that increase production rates, create a safer workplace, and reduce maintenance costs. Marco's industry experience, manufacturing capabilities, legendary customer service, product availability, logistics services, and technology leadership is your assurance that we deliver high quality products and services, providing the best value to you, our customer.

## The Marco Difference

- **Industry Experience** – With Marco on your team, you have access to expertise which can only come from decades of industry leadership. We have organized our engineering department, production specialists, customer operations, and safety support into a “Center of Competence.” As a Marco customer, you have access to hundreds of years of cumulative experience related to your operations.
- **Manufacturing Excellence** – Marco is a manufacturer of equipment for the Surface Preparation and Protective Coatings industries. Marco's engineers benchmark the industry to ensure that we design and manufacture superior products that set the “Gold Standard” for performance, safety, and quality.
- **Legendary Customer Service** – Marco's legendary customer service team is staffed by friendly, highly-trained individuals who are focused on providing the highest level of product support, order accuracy, and customer satisfaction.
- **Product Availability** – We stock over 10,000 SKU's and have more than 45 shipping locations to serve North American and International markets for all major brands of blasting and coating equipment. As the largest provider of surface preparation and protective coatings equipment in the world, our inventory levels and product availability are unmatched.
- **Logistics Services** – Marco's in-house logistics team is dedicated to moving your shipment anywhere in the world. We move more than 14,000 truckloads every year, allowing you to save on freight costs by leveraging our buying power. Lower your process costs with a single invoice, which includes product and freight.
- **Technology Leadership** – Our website provides: Operator's Manuals, Part Numbers and Schematics Guides, SDS information, and Features & Specifications Guides, providing access to information 24/7. Our Extranet application allows you to receive quotes and place orders online. Our Intranet maintains a complete record of your purchase history to assist with ongoing support of your existing equipment and future purchasing decisions.

## Vision Statement

Marco is the world's premier provider of Abrasives, Blasting, Coating, Dust Collectors, Engineered Systems, Rental, Safety, Service, Repair, & Modernization, and Vacuums.

## Mission Statement

Marco provides strong leadership and innovation to the surface preparation and protective coatings industries. We dedicate our efforts to the continuous improvement of our products, services, processes, people, and most importantly, the quality of our customer's experience.

## Quality Statement

Marco is committed to providing superior quality in the design, manufacturing, distribution, rental, service, and repair of our products. Continuous improvement of our processes and supply chain Integration comprise the core of our business strategy for delivering exceptional quality and value in all Marco products and services.

## Management Philosophy

We are a company dedicated to the success of every customer and associate. We discuss, debate, challenge, measure, and test our ideas. We will be boundless and limitless in our passion to improve. Through sound leadership and dedicated associates, we will ensure a long term, profitable future for Marco, our associates, customers, and suppliers.

# TABLE OF CONTENTS

<b>Company Profile</b> .....	1	<b>Troubleshooting</b> .....	13
<b>Operating Instructions</b> .....	9	<b>Limited Warranty</b> .....	14
Description .....	9	Disclaimer of Warranty .....	14
Operational Requirements .....	9	Exclusive Remedy for Warranty Claims .....	14
Operating Instructions .....	9	Limitation of Remedies .....	14
<b>Installation</b> .....	10		
Blastmaster® 157E Remote Control Switches .	10		
<b>Maintenance</b> .....	11		
Disassemble and Assemble Blastmaster®			
157E Remote Control Switch .....	11		

## DEFINITION OF TERMS

### **DANGER**

This is an example of danger. This indicates an imminently hazardous situation which, if not avoided, will result in death or serious injury.

### **CAUTION**

This is an example of a caution. This indicates a potentially hazardous situation which, if not avoided, may result in minor or moderate injury. It can also be used to alert against unsafe practices.

### **WARNING**

This is an example of a warning. This indicates a potentially hazardous situation which, if not avoided, could result in death or serious injury.

### **NOTICE**

This is an example of a notice. This indicates policy or practice directly related to safety of personnel or protection of property.

# HAZARD IDENTIFICATIONS

## **WARNING**

### **Failure to comply with ANY WARNING listed below could result in death or serious injury.**

- ▶ OSHA sets exposure limits to protect workers from exposure to respirable crystalline silica, 29 CFR 1910.1053. Airborne dust could increase the exposure levels beyond permissible limits. Breathing dust containing silica could cause silicosis, a fatal lung disease. Breathing dust during abrasive blasting operations, post-blast cleaning operations, and/or servicing equipment within the abrasive blasting area may expose an individual to conditions that could cause asbestosis, lead poisoning and/or other serious or fatal diseases. Harmful dust containing toxic material from abrasives or surfaces being abrasive blasted can remain suspended in the air for long periods of time after abrasive blasting has ceased. A NIOSH-approved, well-maintained, respirator designed for the specific operation being performed must be used by anyone abrasive blasting, handling or using the abrasive, and anyone in the area of the dust.
- ▶ Contact NIOSH and OSHA offices to determine the proper respirator for your specific application. The air supplied to the respirator must be at least Grade D quality as described in Compressed Gas Association Commodity Specification G-7.1 and as specified by OSHA Regulation 1910.134. Ensure air filter and respirator system hoses are not connected to non-air sources or in-plant lines that may contain nitrogen, oxygen, acetylene or other non-breathable gases. Before removing respirator, use an air monitoring instrument to determine if the atmosphere is safe to breathe.
- ▶ You must comply with all OSHA, local, City, State, Province, Country and jurisdiction regulations, ordinances and standards, related to your particular work area and environment. Keep unprotected individuals out of the work area.
- ▶ Abrasive blasting operators must receive thorough training on the use of abrasive resistant attire which includes: supplied-air respirator, abrasive blasting suit, safety shoes, gloves, ear protection and eye protection. Protect the operator and bystanders by complying with NIOSH and OSHA Safety Standards.
- ▶ Inspect all equipment for wear or damage before and after each use. Failure to use Original Equipment Manufacturer repair parts and failure to immediately replace worn or damaged components could void warranties and cause malfunctions.
- ▶ OSHA requires abrasive blasting nozzles be equipped with an operating valve, which shall be designed to be held open only by continuous hand pressure and shall close immediately upon release of hand pressure (i.e., a “deadman” control). The valve shall not be modified in any manner that would allow it to remain open without the application of continuous hand pressure by the operator. Failure to comply with the above warning could result in release of high speed abrasive and compressed air resulting in death or serious injury. OSHA 29CFR 1910.244(b)
- ▶ Point the abrasive blasting nozzle only at the surface being abrasive blasted. Never point the abrasive blasting nozzle or abrasive stream at yourself or others.
- ▶ Unless otherwise specified, maximum working pressure of abrasive blasting pots and related components must not exceed 150 psi. Exceeding maximum working pressure of 150 psi could cause the abrasive blasting pot and components to burst. Failure to comply with the above warning could result in death or serious injury.
- ▶ Never weld, grind or drill on the abrasive blasting pot (or any pressure vessel). Doing so will void ASME certification and manufacturer’s warranty. Welding, grinding or drilling on the abrasive blasting pot (or any pressure vessel) could weaken the vessel causing it to burst. Failure to comply with the above warning could result in death or serious injury. (ASME Pressure Vessel Code, Section VIII, Division 1)
- ▶ This equipment is not intended for use in any area that might be considered a hazardous location, as described in the National Electric Code NFPA 70, Article 500. Use of this equipment in a hazardous location could cause an explosion or electrocution.
- ▶ Never attempt to move an abrasive blasting pot containing abrasive. Never attempt to manually move abrasive blasting pots greater than 6.5 cubic foot capacity. Always use at least two capable people to manually move an abrasive blasting pot on flat, smooth surfaces. A mechanical lifting device must be used if an abrasive blasting pot is moved in any other manner.

# HAZARD IDENTIFICATIONS

## **WARNING**

**Failure to comply with ANY WARNING listed below could result in death or serious injury.**

- ▶ This product is not for use in wet environments. Always use a Ground Fault Interrupter Circuit (GFI) for all electrical power source connections. Use of this product in wet environments could create a shock or electrocution hazard.
- ▶ Frozen moisture could cause restrictions and obstructions in pneumatic control lines. Any restriction or obstruction in the pneumatic control lines could prevent the proper activation and deactivation of the remote control system, resulting in the release of high speed abrasive and compressed air. In conditions where moisture may freeze in the control lines an antifreeze injection system approved for this application can be installed.
- ▶ Do not cut, obstruct, restrict or pinch pneumatic control lines. Doing so could prevent the proper activation and deactivation of the remote control system, resulting in the release of high speed abrasive and compressed air.
- ▶ Use of Marco remote control switches with other manufacturer's remote control systems could cause unintended activation of remote control systems resulting in the release of high speed abrasive and compressed air. Only Marco remote control switches should be used with Marco remote control systems.
- ▶ Always be certain to have secure footing when abrasive blasting. There is a recoil hazard when abrasive blasting starts that may cause user to fall and misdirect the abrasive stream at operator or bystander.
- ▶ Never use an abrasive blasting pot or attachments as a climbing device. The person could slip and fall. The abrasive blasting pot could become unstable and tip over.
- ▶ For equipment manufactured by entities other than Marco, you must consult the Original Equipment Manufacturer operator's manuals, information, training, instructions and warnings, for the proper and intended use of all equipment.
- ▶ Flammable fumes, such as solvent and paint fumes in the work area can present an ignition or explosion hazard if allowed to collect in adequate concentrations. To reduce conditions that could result in a fire or an explosion, provide adequate ventilation, eliminate all ignition or spark sources, keep the work area free of debris, store solvents and solvent contaminated rags in approved containers, follow proper grounding procedures, do not plug/unplug power cord or turn on/off power switches when flammable fumes are present, keep a working fire extinguisher or provide another fire suppression system in the work area. Cease all operations and correct condition if a spark or ignition source is identified during operation.
- ▶ Always depressurize the entire system, disconnect all power sources and lockout/tagout all components before any maintenance or troubleshooting is attempted. Failure to comply with the above warning could cause electrical shock and inadvertent activation of equipment resulting in death or serious injury.
- ▶ Moving parts can present an area where crushing, pinching, entanglement or amputation may occur. Do not place body parts or foreign objects in any area where there are moving parts.
- ▶ Surfaces of heated supply tanks, drums and/or lines as well as the adjoining plumbing may become hot during normal use. Do not touch these heated surfaces without proper protection. Deactivate and allow sufficient time for all surfaces to cool before attempting any maintenance.
- ▶ High-pressure fluid from gun, hose leaks, or ruptured components can pierce skin and can cause a serious injury that may result in amputation. Do not point gun or spray tip at anyone or at any part of the body. Keep clear of any leaks or ruptures. Depressurize the entire system before attempting cleaning, inspecting, or servicing equipment.
- ▶ Exposure to toxic fluids or fumes may occur during the normal operation of this system. Before attempting to fill, use, or service this system, read SDS's to know the specific hazards of the fluids you are using. Always use proper Personal Protective Equipment when attempting to fill, use, or service this system.
- ▶ The use of this product for any purpose other than originally intended or altered from its original design is prohibited.
- ▶ Never hang objects from the abrasive blasting pot handle. Doing so may cause the abrasive blasting pot to become unstable and tip over.

## HAZARD IDENTIFICATIONS

### CAUTION

**Failure to comply with ANY CAUTION listed below may result in minor or moderate injury.**

- ▶ Static electricity can be generated by abrasive moving through the abrasive blasting hose causing a shock hazard. Prior to use, ground the abrasive blasting pot and abrasive blasting nozzle to dissipate static electricity.
- ▶ High decibel noise levels are generated during the abrasive blasting process which may cause loss of hearing. Ensure appropriate Personal Protective Equipment and hearing protection is in use.

### NOTICE

**Failure to comply with ANY NOTICE listed below could pose a hazard to personnel or property.**

- ▶ See Air & Abrasive Consumption Chart for estimated abrasive consumption rates and required air flow (cubic feet per minute). Your system must meet these minimum requirements to ensure proper function and performance.
- ▶ Always use abrasive that is dry and properly screened. This will reduce the potential for obstructions to enter the remote control system, abrasive metering valve and abrasive blasting nozzle.
- ▶ Moisture build-up occurs when air is compressed. Any moisture within the abrasive blasting system will cause abrasive to clump, clogging metering valves, hoses and nozzles. Install an appropriately sized moisture separator at the inlet of the abrasive blasting system. Leave the moisture separator petcock slightly open to allow for constant release of water. If insufficient volume of air exists and petcock is unable to be left open (at all times) petcock should be opened frequently to release water.
- ▶ To reduce abrasive intrusion in the air supply hose, depressurize the abrasive blasting pot before shutting off air supply from compressor.
- ▶ Inspect abrasive blasting nozzle before placing into service. Damage to abrasive blasting nozzle liner or jacket may occur during shipping. If you receive a damaged abrasive blasting nozzle, contact your distributor immediately for replacement. Abrasive blasting nozzles placed into service may not be returned. Abrasive blasting nozzle liners are made of fragile materials and can be damaged by rough handling and striking against hard surfaces. Never use a damaged abrasive blasting nozzle.
- ▶ Abrasive blasting at optimal pressure for the abrasive used is critical to productivity. Example: For an abrasive with an optimal abrasive blasting pressure of 100 psi at the abrasive blasting nozzle, one pound per square inch of pressure loss will reduce abrasive blasting efficiency by 1.5%. A 10 psi reduction in air pressure will cause a 15% loss of efficiency. Use a Needle Pressure Gauge to identify pressure drops in your system. Consult with your abrasive supplier for the requirements of your abrasive.
- ▶ Replace abrasive blasting nozzle if liner or jacket is cracked or damaged. Replace abrasive blasting nozzle if original orifice size has worn 1/16" or more. Determine abrasive blasting nozzle wear by inserting a drill bit 1/16" larger than original size of abrasive blasting nozzle orifice. If the drill bit passes through abrasive blasting nozzle, replacement is needed.

# AIR & ABRASIVE CONSUMPTION CHART

## NOTICE

Failure to comply with ANY NOTICE listed below could pose a hazard to personnel or property.

- ▶ See Air & Abrasive Consumption Chart for estimated abrasive consumption rates and required air flow (cubic feet per minute). Your system must meet these minimum requirements to ensure proper function and performance.
- ▶ When it comes to air & abrasive mixtures, more is not necessarily better. Optimum abrasive blasting efficiency takes place when a lean air & abrasive mixture is used. To correctly set the abrasive metering valve, begin with the valve fully closed and slowly increase the amount of abrasive entering the airstream. As you increase the abrasive flow, watch for a “blue flame” at the exit of the abrasive blasting nozzle. Faster cutting, reduced abrasive consumption and lower clean up costs, are benefits of the “blue flame”.
- ▶ Abrasive blasting at optimal pressure for the abrasive used is critical to productivity. Example: For an abrasive with an optimal abrasive blasting pressure of 100 psi at the abrasive blasting nozzle, one pound per square inch of pressure loss will reduce abrasive blasting efficiency by 1.5%. A 10 psi reduction in air pressure will cause a 15% loss of efficiency. Use a Needle Pressure Gauge to identify pressure drops in your system. Consult with your abrasive supplier for the requirements of your abrasive.

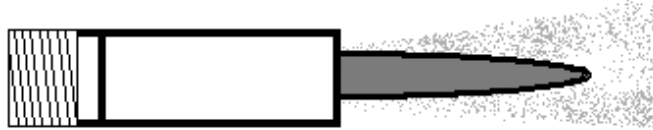

“Blue Flame”

Air & Abrasive Consumption Chart\*

Inspect abrasive blasting nozzle before placing into service. Damage to abrasive blasting nozzle liner or jacket may occur during shipping. If you receive a damaged abrasive blasting nozzle, contact your distributor immediately for replacement. Abrasive blasting nozzles placed into service may not be returned. Abrasive blasting nozzle liners are made of fragile materials and can be damaged by rough handling and striking against hard surfaces. Never use a damaged abrasive blasting nozzle.

Nozzle Orifice	Pressure at the Nozzle (PSI)								Air (in cfm), Abrasive & Compressor Requirements
	50	60	70	80	90	100	125	140	
No. 2 (1/8")	11	13	15	17	18	20	25	28	Air (cfm)
	67	77	88	101	112	123	152	170	Abrasive (lbs/hr)
	2.5	3	3.5	4	4.5	5	5.5	6.2	Compressor Horsepower
No. 3 (3/16")	26	30	33	38	41	45	55	62	Air (cfm)
	150	171	196	216	238	264	319	357	Abrasive (lbs/hr)
	6	7	8	9	10	10	12	13	Compressor Horsepower
No. 4 (1/4")	47	54	61	68	74	81	98	110	Air (cfm)
	268	312	354	408	448	494	608	681	Abrasive (lbs/hr)
	11	12	14	16	17	18	22	25	Compressor Horsepower
No. 5 (5/16")	77	89	101	113	126	137	168	188	Air (cfm)
	468	534	604	672	740	812	982	1100	Abrasive (lbs/hr)
	18	20	23	26	28	31	37	41	Compressor Horsepower
No. 6 (3/8")	108	126	143	161	173	196	237	265	Air (cfm)
	668	764	864	960	1052	1152	1393	1560	Abrasive (lbs/hr)
	24	28	32	36	39	44	52	58	Compressor Horsepower
No. 7 (7/16")	147	170	194	217	240	254	314	352	Air (cfm)
	896	1032	1176	1312	1448	1584	1931	2163	Abrasive (lbs/hr)
	33	38	44	49	54	57	69	77	Compressor Horsepower
No. 8 (1/2")	195	224	252	280	309	338	409	458	Air (cfm)
	1160	1336	1512	1680	1856	2024	2459	2754	Abrasive (lbs/hr)
	44	50	56	63	69	75	90	101	Compressor Horsepower
No. 10 (5/8")	308	356	404	452	504	548	663	742	Air (cfm)
	1875	2140	2422	2690	2973	3250	3932	4405	Abrasive (lbs/hr)
	68.5	79.5	90	100.5	112	122	146	165	Compressor Horsepower
No. 12 (3/4")	432	504	572	644	692	784	948	1062	Air (cfm)
	2672	3056	3456	3840	4208	4608	5570	6238	Abrasive (lbs/hr)
	96	112	127	143	154	174.5	209	236	Compressor Horsepower

\*Abrasive consumption is based on abrasive with a bulk density of 100 lbs per Cubic Foot

## NOTICE

Replace abrasive blasting nozzle if liner or jacket is cracked or damaged. Replace abrasive blasting nozzle if original orifice size has worn 1/16" or more. Determine abrasive blasting nozzle wear by inserting a drill bit 1/16" larger than original size of abrasive blasting nozzle orifice. If the drill bit passes through abrasive blasting nozzle, replacement is needed.

# “THE BIG PICTURE”

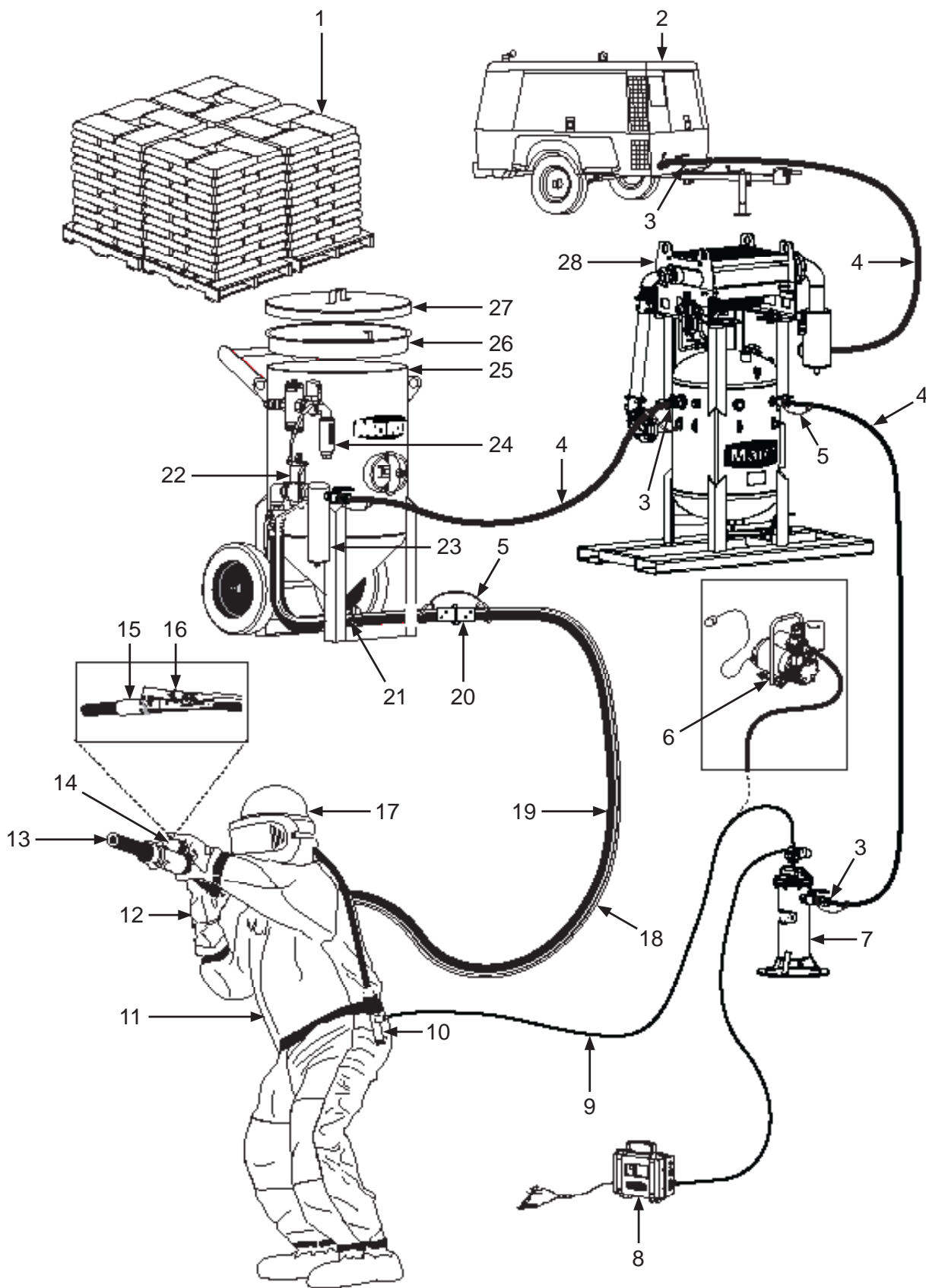



# DAILY PRE-OPERATION CHECKLIST

## Daily Pre-operation Checklist

- 1. Abrasive
- 2. Air Compressor
- 3. Air Hose Couplings & Gaskets
- 4. Air Hose
- 5. Safety Cable
- 6. Ambient Air Pump\*
- 7. Breathing Air Filter
- 8. CO Monitor
- 9. Breathing Line
- 10. Climate Control Device
- 11. Abrasive Blasting Suit
- 12. Gloves
- 13. Abrasive Blasting Nozzle
- 14. Lighting System\*
- 15. Abrasive Blasting Nozzle Holder
- 16. Remote Control Switch
- 17. Supplied-Air Respirator
- 18. Control Line
- 19. Abrasive Blasting Hose
- 20. Abrasive Blasting Hose Couplings & Gaskets
- 21. Abrasive Metering Valve
- 22. Remote Control System
- 23. Moisture Separator
- 24. Abrasive Blasting Pot Exhaust Muffler
- 25. Abrasive Blasting Pot
- 26. Abrasive Blasting Pot Screen
- 27. Abrasive Blasting Pot Lid
- 28. Aftercooler\*

\* *Optional or alternative device. Ask your Marco Representative for more details.*

**Abrasive** – Select the correct Abrasive (1) for the application. Review the SDS (*Safety Data Sheet*) to ensure the correct PPE (*Personal Protective Equipment*) and Environmental Controls have been selected and are in place.

**Air Compressor** – Select an Air Compressor (2) of adequate size to support all equipment requirements. Refer to “Air & Abrasive Consumption Chart” for Abrasive Blasting Nozzle (13) air consumption requirements. Before connecting Air Hose (4), sample the air being produced by the air compressor (2) to ensure it is free of petroleum contaminants.

**Air Hose, and Air Hose Couplings & Gaskets** – Select Air Hoses (4) of sufficient size to support all subsequent volumetric requirements and with a sufficient PSI (*pound per square inch*) rating. Inspect all Air Hoses (4), and Air Hose Couplings & Gaskets (3) for damage or wear. Repair or replace damaged or worn components.

**Abrasive Blasting Hose, Abrasive Blasting Hose Couplings & Gaskets, and Abrasive Blasting Nozzle Holder** – Select an Abrasive Blasting Hose (19) that has an inner diameter 3 to 4 times larger than your Abrasive Blasting Nozzle (13). Inspect Abrasive Blasting Hose (19), Abrasive Blasting Hose Couplings & Gaskets (20), and Abrasive Blasting Nozzle Holder (15) for damage or wear. Repair or replace damaged or worn components.

**Safety Cables** – Install a Safety Cable (5) at each Abrasive Blasting Hose (19), and Air Hose (4) connection points.

**Aftercooler and Moisture Separator** – Ensure Aftercooler (28) is positioned on stable ground. Keep petcock drain of Moisture Separator (23) slightly open during use. Drain both devices after each use.

**Supplied-Air Respirator, Breathing Line, Breathing Air Filter, Climate Control Device, CO Monitor, Ambient Air Pump** – You MUST consult the Operator’s Manual supplied with your Respiratory Equipment (6, 7, 8, 9, 10, 17) for ALL applicable instructions and warnings. Inspect all Respiratory Equipment components for damage or wear. Repair or replace damaged or worn components.

**Abrasive Blasting Suit and Gloves** – Select an abrasive-resistant Abrasive Blasting Suit (11) that is slightly oversized to allow ease of movement and allows air to flow around your body. Select abrasive-resistant Gloves (12) with a tight fit and a long cuff that overlaps the sleeve of the Abrasive Blasting Suit (11).

**Abrasive Metering Valve and Abrasive Blasting Pot** – Confirm Abrasive Blasting Pot (25) is positioned on stable ground. Inspect Abrasive Blasting Pot (25) and Abrasive Metering Valve (21) for damage or wear. Repair or replace damaged or worn components.

**Abrasive Blasting Pot Screen and Abrasive Blasting Pot Lid** – Always use an Abrasive Blasting Pot Screen (26) when filling Abrasive Blasting Pot (25) with Abrasive (1) to prevent debris from entering the Abrasive Blasting Pot (25). Remove Abrasive Blasting Pot Lid (27) before operating the Abrasive Blasting Pot (25). Install Abrasive Blasting Pot Lid (27) after use to protect the Abrasive Blasting Pot’s (25) interior.

**Remote Control System, Remote Control Switch, Control Line,** – Inspect Remote Control System (22) and Control Line (18) for damage or wear. Repair or replace damaged or worn components. Ensure Control Line (18) fittings connected to the Remote Control System (22) are tight and free of leaks. Ensure Remote Control Switch (16) is functioning properly. Consult Remote Control Switch Operator’s Manual for applicable instructions.

**Abrasive Blasting Pot Exhaust Muffler** – Inspect Abrasive Blasting Pot Exhaust Muffler (24) at start and end of daily use. Replace element of Abrasive Blasting Pot Exhaust Muffler (24) per Operator’s Manual instructions.

**Lighting System** – Ensure the Lighting System (14) is connected to a proper power supply before use.

# OPERATING INSTRUCTIONS

## **WARNING**

Use of Marco remote control switches with other manufacturer's remote control systems could cause unintended activation of remote control systems resulting in the release of high speed media and compressed air. Only Marco remote control switches should be used with Marco remote control systems. Failure to comply with the above warning could result in death or serious injury.

## **WARNING**

OSHA requires abrasive blasting nozzles be equipped with an operating valve, which shall be designed to be held open only by continuous hand pressure and shall close immediately upon release of hand pressure (i.e., a "deadman" control). The valve shall not be modified in any manner that would allow it to remain open without the application of continuous hand pressure by the operator. Failure to comply with the above warning could result in release of high speed media and compressed air resulting in death or serious injury. OSHA 29 CFR 1910.244(b)

## **WARNING**

W-519

This product is not for use in wet environments. Always use a Ground Fault Interrupter Circuit (GFIC) for all electrical power source connections. Use of this product in wet environments could create a shock or electrocution hazard. Failure to comply with the above warning could result in death or serious injury.

## Description

A remote control switch gives an operator the ability to remotely activate and deactivate the remote control system at the blast nozzle. An electric remote control switch reduces the time required to activate and deactivate the remote control system compared to a pneumatic remote control switch. The reduced time is most noticeable when the operator is working at distances greater than 100 feet from the blast pot. The Blastmaster 157E Remote Control Switch is a multi-function, three-wire switch for use with any electric blast pot remote control system. Typical applications include blast rooms, blast yards, bridges, oil refineries, pipelines, railcar shops, shipyards, and storage tanks.

## Operational Requirements

**The following may cause safety hazards or reduced performance:**

- Improper installation and/or maintenance of components.
- Use of anything other than hand pressure to activate remote control switch.
- Allowing anything to obstruct operation or release.

## Operating Instructions

**Before using:**

- Set up abrasive blasting pot and remote control system. (See Operator's Manuals.)
- Inspect electric control line and connectors for cracks, abrasion, or damage.
- Inspect Toggle Boot (1) for damage. Replace immediately if damaged.
- Test switch for free movement. Switch must return to OFF (center) position immediately upon release.

**During use:**

- Activate remote control switch using thumb/finger by pushing up or down on the Toggle Boot (1).
- To cease abrasive blasting, release Toggle Boot (1). Ensure Toggle Boot returns to OFF (center) position.

**After use:**

- When abrasive blasting is concluded, inspect components for damage. Store abrasive blasting hose with remote control switch attached in an area clear of debris and abrasive.

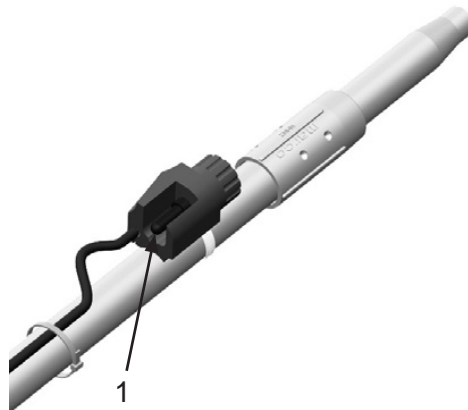

# INSTALLATION

## Blastmaster® 157E Remote Control Switches

### NOTICE

Pulling and dragging abrasive blasting hose may cause control line and power cord connections to separate. Connect the control line and power cord to the abrasive blasting hose every 4 to 6 feet and on each side of the control line connections. Provide adequate slack at each connection.

### NOTICE

Use 16 gauge power cord for lengths up to 300 feet. To reduce electrical resistance, use larger gauge electric cord.

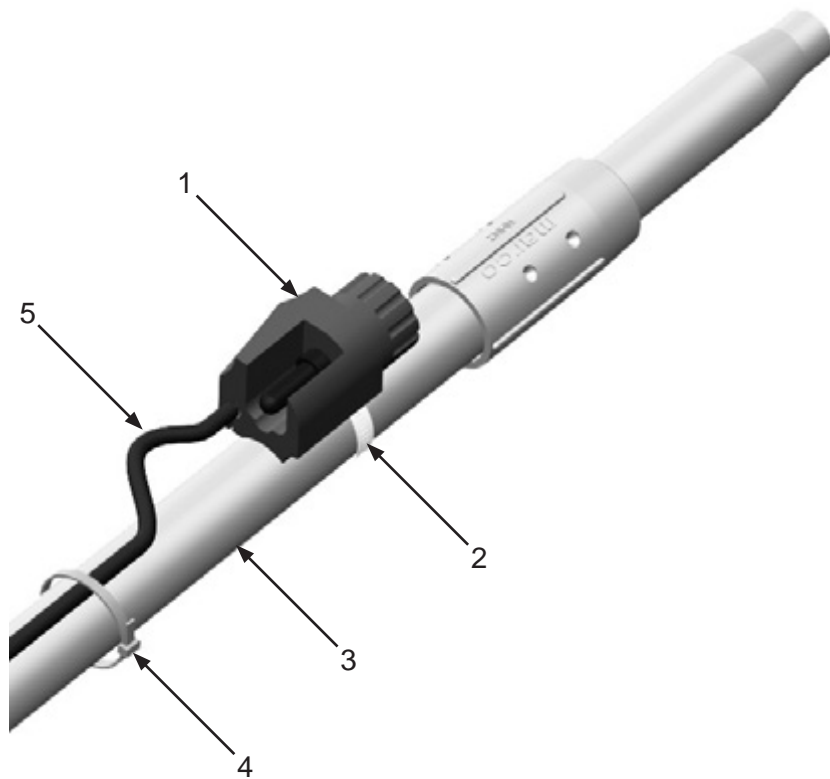

### Installation

- 1) Attach Remote Control Switch (1) to Abrasive Blasting Hose (3) using Hose Clamp (2).
- 2) Secure Electric Control Line (5) to Abrasive Blasting Hose (3) every 4 to 6 feet, and on each side of the hose connections. Provide adequate slack at each connection.
- 3) Install a Cord Connector or Electrical Plug to the exposed end of the Electric Control Line (5).

# MAINTENANCE

## Disassemble and Assemble Blastmaster® 157E Remote Control Switch

### WARNING

Always depressurize the entire blasting system, disconnect all power sources and lockout/tagout all components before any maintenance or troubleshooting is attempted. Failure to comply with the above warning could cause electrical shock and inadvertent activation of equipment resulting in death or serious injury.

### WARNING

The use of this product for any purpose other than originally intended or altered from its original design is prohibited. Failure to comply with the above warning could result in death or serious injury.

Maintenance of the Blastmaster® 157E Remote Control Switch is limited to the daily cleaning and the immediate replacement of damaged or worn parts.

*Note: Anytime a switch is being replaced, the cord supplied with switch should be replaced and discarded.*

#### **Disassemble:**

- 1) Disconnect switch from power source.
  - 2) Remove Cap (1) by turning counter-clockwise.
- Note: Note that terminals 1, 2 and 3 on Switch (2) and the threads in Cap (1) have silicone on them. This silicone must be removed from all surfaces.*
- 3) Cut cord (5) at location (7).
  - 4) Loosen Screws (6) by rotating counterclockwise four full turns.
  - 5) Remove Boot (4) by unscrewing counterclockwise.
  - 6) Remove Switch (2) by pushing on end of exposed Toggle (8).
  - 7) Remove any residual silicone.

#### **Assemble:**

- 1) Install Electric Control Line (5) into Switch Body (3).
  - 2) Taking switch (2) in hand, slide switch into place with the groove on Threads (9) facing down. Pull Electric Control Line through Switch Body until Switch (2) seats in Switch Body.
- Note: When Switch (2) is properly seated, Terminal #1 (10) will be on top.*
- 3) To connect cord, the white wire should be connected to *Terminal #1* (10), the black wire connected to *Terminal #2* (11) and the green wire connected to *Terminal #3* (12).
  - 4) Decrease the amount of excess wire located in the switch cavity by pulling on cord (5) until all of the excess has been removed.
  - 5) Tighten Screws (6) by rotating clockwise four full turns.
  - 6) Install boot (4) by rotating clockwise on Threads (9), making sure that the boot is on snugly. Over-tightening will cause damage to the boot and nullify its effectiveness. One full turn of the boot after it has reached its position should suffice.

*Note: Depressing boot will activate white wire. Raising boot will activate green wire.*

- 7) Check for electrical continuity by connecting White And Black wires to a flashlight continuity checker, then depressing boot. Light should come on. Repeat this procedure with Green And Black wires, raising boot. Light should come on. Under no circumstances should light come on when boot is in the center (neutral) position.

*Note: If the switch is not working properly, recheck steps 1 through 4.*

- 8) Apply a sufficient amount of silicone to completely cover to terminals 1, 2, & 3. Apply a small amount of silicone to female threads in cap (1) and install cap (1) by rotating clockwise approximately 3 times.

# MAINTENANCE

## Disassemble and Assemble Blastmaster® 157E Remote Control Switch (cont.)

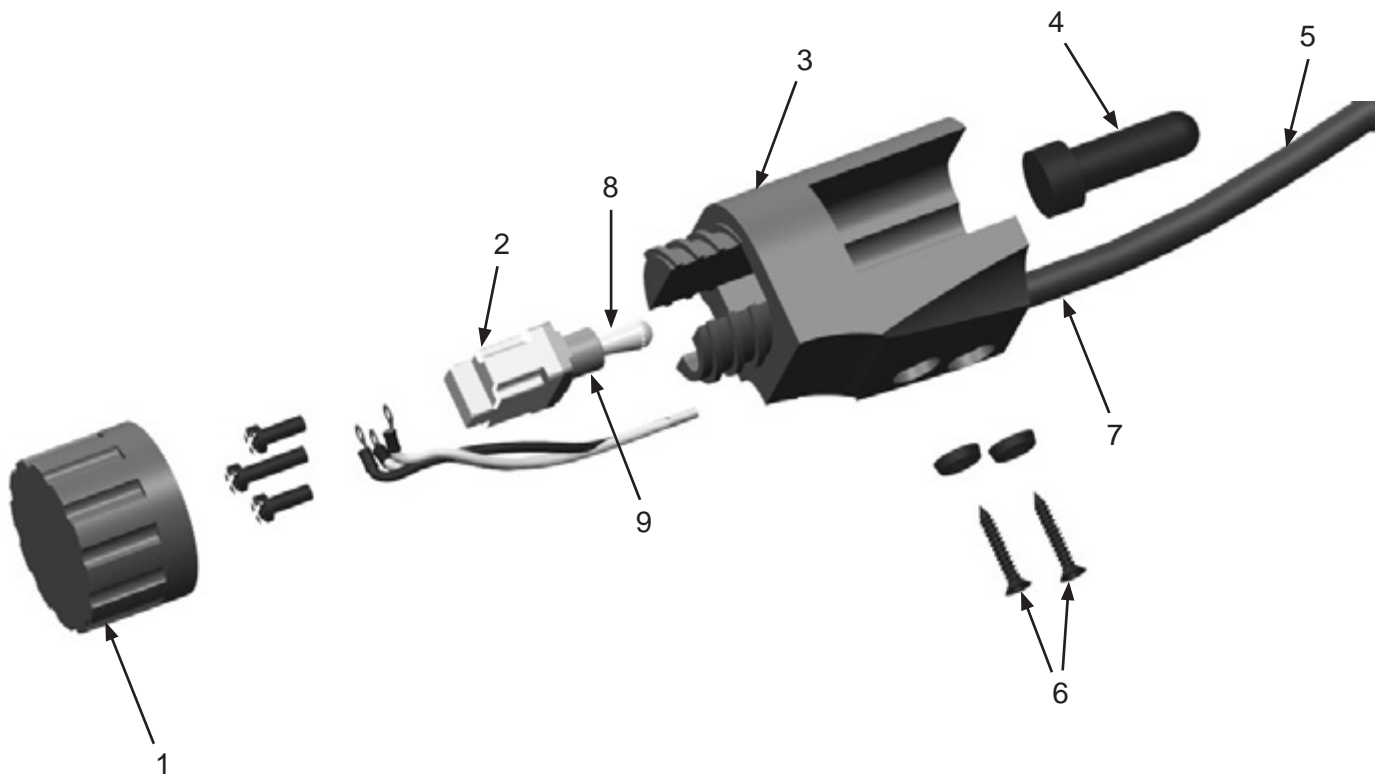
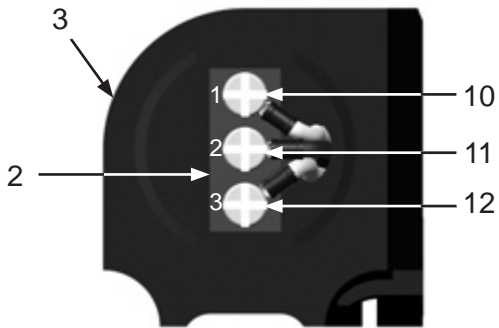

# TROUBLESHOOTING

## WARNING

Always depressurize the entire blasting system, disconnect all power sources and lockout/tagout all components before any maintenance or troubleshooting is attempted. Failure to comply with the above warning could cause electrical shock and inadvertent activation of equipment resulting in death or serious injury.

## NOTICE

Use 16 gauge power cord for lengths up to 300 feet. To reduce electrical resistance, use larger gauge electric cord.

If the Blastmaster® 157E Remote Control Switch does not function properly, check the following:

---

### **SYMPTOM (Cause)**

### **ACTION**

---

#### **Control Switch operates in only one direction**

*(Debris or foreign object, damaged Toggle Boot, or Toggle Switch.)*

Clean around Toggle boot. Remove any debris.

Replace Toggle Boot if damaged.

Replace Blastmaster® 157E Remote Control Switch or repair using the repair kit.

---

#### **Remote Control System fails to operate when Control Switch is activated**

*(Power interrupted, debris or foreign object, damaged Toggle Switch, Remote Control System failure)*

Inspect all electric control lines and connections.

Clean around Toggle Boot. Remove any debris.

Replace Toggle Boot if damaged.

Replace Blastmaster® 157E Remote Control Switch or repair using the repair kit.

See remote control system Operator's Manual.

---

#### **Switch DOES NOT return to OFF (center) position**

*(Debris or foreign object, damaged Toggle Boot or Toggle Switch.)*

Clean around Toggle Boot. Remove any debris.

Replace Blastmaster® 157E Remote Control Switch or repair using the repair kit.

---

## **ADDITIONAL TECHNICAL DATA**

The associations listed below offer information, materials and videos pertaining to abrasive blasting and safe operating practices.

- **American Society for Testing and Materials (ASTM)**  
100 Barr Harbor Drive  
West Conshohocken, PA 19428-2959  
Phone: (610) 832-9585  
FAX: (610) 832-9555  
www.astm.org
- **Occupational Safety & Health Administration (OSHA)**  
United States  
Department of Labor  
200 Constitution Avenue  
Washington, DC 20210  
Phone: (800) 321-OSHA  
(800) 321-6742  
www.osha.gov
- **The National Board of Boiler & Pressure Vessel Inspectors**  
1055 Crupper Avenue  
Columbus, Ohio 4322  
Phone: (614) 888-8320  
FAX: (614) 888-0750  
www.nationalboard.org
- **National Association of Corrosion Engineers (NACE)**  
1440 South Creek Drive  
Houston, TX 77084-4906  
Phone: (281) 228-6200  
FAX: (281) 228-6300  
www.nace.org
- **The Society for Protective Coatings (SSPC)**  
40-24th Street, 6th Floor  
Pittsburgh, PA 15222-4656  
Phone: (412) 281-2331  
FAX: (412) 281-9992  
www.sspc.org
- **American National Standards Institute (ANSI)**  
1899 L Street, NW, 11th Floor  
Washington, DC 20036  
Phone: (202) 293-8020  
FAX: (202) 293-9287  
www.ansi.org

### **Limited Warranty:**

Seller warrants to the original Purchaser that any MARCO manufactured product covered by this Limited Warranty will remain free from defects in workmanship or material under normal commercial use and service for a period of one year from the date of shipment to the original Purchaser. This Warranty shall not apply to defects arising, in whole or in part, from any accident, negligence, alteration, misuse or abuse of the Product, operation of the Product which is not in accordance with applicable instructions or manuals or under conditions more severe than, or otherwise exceeding, those set forth in the written specifications for the Product, nor shall this Warranty extend to repairs or alterations of the Product and/or any maintenance part by persons other than Seller or Seller's authorized representatives. This warranty does not apply to accessory items or third-party manufactured product. Further, this Warranty does not apply to damage or wear to the surface finish or appearance of the Product or normal wear and tear to the Product. This Warranty is limited to a purchaser who purchases the Product either directly from the Seller or from one of Seller's "Authorized Distributors". An Authorized Distributor is a Seller approved distributor that purchases the Product directly from the Seller for the sole purpose of re-selling the Product at retail, without any use or modifications whatsoever, to an end-purchaser. This warranty is specifically non-assignable and non-transferable. All third-party manufactured product will be covered by original manufacturer warranties.

### **Disclaimer of Warranty:**

This warranty is exclusive and, except as stated herein, MARCO makes no express or implied warranties as to any matter whatsoever, including, without limitation, the warranty of merchantability and fitness for a particular, which exceed the foregoing warranty. Purchaser's sole remedy and MARCO's sole obligation arising out of or in connection with defects in materials, workmanship or services, which are based on warranty, contract, negligence, strict liability or otherwise, shall be those stated in the following Section 4. The Purchaser acknowledges that any affirmation of fact or promise made by MARCO shall not be deemed to create an express warranty, that Purchaser is not relying on MARCO's skill or judgment in selecting or furnishing a system suitable for any particular purpose, and there are no warranties which extend beyond the description on the face hereof.

### **Exclusive Remedy for Warranty Claims:**

The sole and exclusive remedy under the foregoing limited warranty, and to the extent permitted by law, any warranty or condition implied by law, covering this product shall be, at the seller's option, the repair or replacement, free of charge, F.O.B. point of manufacture, of any defective part or parts of the product that were manufactured by seller, and which are returned to seller at seller's principal place of business, postage prepaid by the Purchaser. This sole and exclusive remedy is conditioned upon Purchaser's prompt written notice to seller at seller's place of business that a defect has been discovered, together with a reasonably detailed description of the defect in the product, proof of purchase of the product, and the model and identification number of the product within thirty (30) days after discovery of the defect, otherwise such claims shall be deemed waived. No allowance will be granted for any repairs or alterations made by Purchaser or others without seller's prior written consent. If such notice is timely given, seller will have the option to either modify the product or component part thereof to correct the defect, replace the product or part with complying products or parts, or refund the amount paid for the defective product, any one of which will constitute the sole liability of seller and full settlement of all claims. In no event shall seller be liable for any obligation greater than the original purchase price of the product under this warranty. Purchaser shall afford seller prompt and reasonable opportunity to inspect the product for which a claim is made. The sole purpose of the foregoing stipulated exclusive remedy shall be to repair or replace defective products or components thereof or to refund purchaser the purchase price thereof. This stipulated exclusive remedy shall not be deemed to have failed of its essential purpose so long as seller is willing and able to repair or replace the defective parts or refund the purchase price in accordance with the terms hereof. Products that have been repaired or replaced under this warranty do not receive a new warranty and are only covered by the remaining portion of the original warranty.

### **Limitation of Remedies:**

The foregoing stipulated exclusive remedy is in lieu of all other remedies for breach of contract, warranty, and/or tort or otherwise. Seller shall not be liable, either directly or indirectly, for any consequential, incidental or special losses or damages of Purchaser, including but not limited to the Purchaser's expenses for downtime or for making up downtime, damages for which the Purchaser may be liable to other persons and/or entities, damages to property, and injury to or death of any persons and/or any claims for incidental or consequential damages, including but not limited to loss of profits, regardless of whether Seller has been informed of the possibility of such damages. Seller neither assumes, nor authorizes any person to assume for it, any other liability in connection with the sale or use of any Products covered by the foregoing Warranty and Disclaimers, and there are no oral agreements relating to remedies which are collateral to or which affect this limitation.

