

OPERATOR'S MANUAL

BLASTMASTER® 123P REMOTE CONTROL SYSTEM

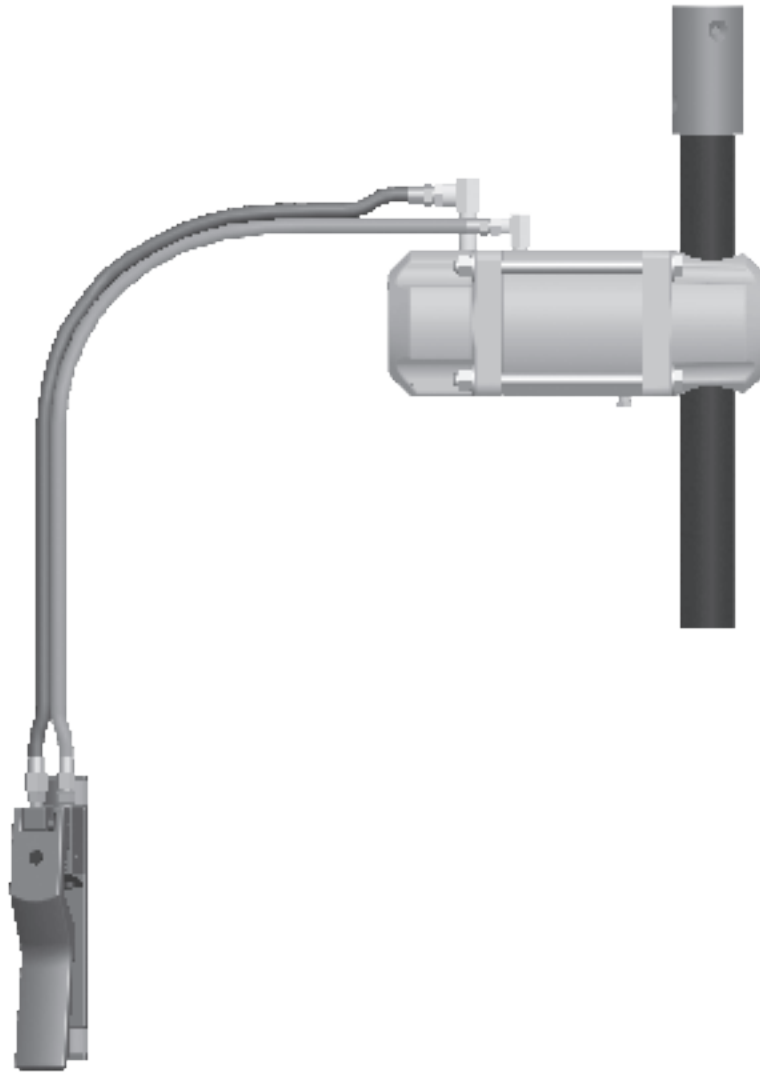

**BUILT MARCO
TOUGH**
MARCO MANUFACTURED

⚠ WARNING

Before using this equipment, read, understand and follow all instructions in the Operator's Manuals provided with this equipment. If the user and/or assistants cannot read or understand the warnings and instructions, the employer of the user and/or assistants must provide adequate and necessary training to ensure proper operation and compliance with all safety procedures pertaining to this equipment. If Operator's Manuals have been lost, please visit www.marco.us, or contact Marco at 563.324.2519 for replacements. Failure to comply with the above warning could result in death or serious injury.

Marco

Company Profile

Since 1944, Marco has developed a strong tradition of providing innovative and reliable products and services to the surface preparation and protective coatings industries. We are the world's premier provider of Abrasives, Blasting Equipment, Coating and Painting Equipment, Engineered Systems, Rental Equipment, Safety Equipment, Service, and Repair.

Through innovative designs and a total commitment to quality, Marco manufactures products that increase production rates, create a safer workplace, and reduce maintenance costs. Marco's industry experience, manufacturing capabilities, legendary customer service, product availability, logistics services, and technology leadership is your assurance that we deliver high quality products and services, providing the best value to you, our customer.

The Marco Difference

- **Industry Experience** – With Marco on your team, you have access to expertise which can only come from over 65 years of industry leadership. We have organized our engineering department, production specialists, customer operations, and safety support into a “Center of Competence.” As a Marco customer, you have access to hundreds of years of cumulative experience related to your operations.
- **Manufacturing Excellence** – Marco is a U.S. based, ISO 9001:2008 certified manufacturer of equipment for the Surface Preparation and Protective Coatings industries. Marco's engineers benchmark the industry to ensure that we design and manufacture superior products that set the “Gold Standard” for performance, safety, and quality.
- **Legendary Customer Service** – Marco's legendary customer service team is staffed by friendly, highly-trained individuals who are focused on providing the highest level of product support, order accuracy, and customer satisfaction.
- **Product Availability** – We stock over 10,000 SKU's and have over 45 shipping locations to serve North American and International markets for all major brands of blasting and painting equipment. As the largest provider of surface preparation and protective coatings equipment in the world, our inventory levels and product availability are unmatched.
- **Logistics Services** – Marco's in-house logistics team is dedicated to moving your shipment anywhere in the world. We move over 14,000 truckloads every year, allowing you to save on freight costs by leveraging our buying power. Lower your process costs with a single invoice, which includes product and freight.
- **Technology Leadership** – Our website provides: Operator's Manuals, Part Numbers and Schematics Guides, MSDS information, and Features, Advantages, and Benefits Guides, providing access to information 24/7. Our Extranet application allows you to receive quotes and place orders online. Our Intranet maintains a complete record of your purchase history to assist with ongoing support of your existing equipment and future purchasing decisions.

Vision Statement

Marco is the world's premier provider of Abrasives, Blasting Equipment, Coating and Painting Equipment, Engineered Systems, Rental Equipment, Safety Equipment, Service, and Repair.

Mission Statement

Marco provides strong leadership and innovation to the surface preparation and protective coatings industries. We dedicate our efforts to the continuous improvement of our products, services, processes, people, and most importantly, the quality of our customer's experience.

Quality Statement

Marco is committed to providing superior quality in the design, manufacturing, distribution, rental, service, and repair of our products. Our ISO 9001:2008 certification extends throughout all operations in all locations. Continuous improvement of our processes and supply chain integration comprise the core of our business strategy for delivering exceptional quality and value in all Marco products and services.

Management Philosophy

We are a company dedicated to the success of every customer and associate. We discuss, debate, challenge, measure, and test our ideas. We will be boundless and limitless in our passion to improve. Through sound leadership and dedicated associates, we will ensure a long term, profitable future for Marco, our associates, customers, and suppliers.

DEFINITION OF TERMS

Company Profile	1	Troubleshooting	15-16
Definition of Terms	2	Assembly Part Numbers & Schematics . . .	17-18
Hazard Identifications	3-6	Blastmaster® 123P Remote Control	
Air & Abrasive Consumption Chart	6	System	17
Daily Pre-operation Checklist	7-8	Tandem Remote Control Valve	18
Blastmaster® 123P Remote		Maintenance Notes.	19-21
Control System	9-18	Warranty	22
Description	9	Disclaimer of Warranty.	22
Operating Requirements	9	Exclusive Remedies for Warranty Claims.	22
Operating Instructions	9-10	Limitation of Remedies.	22
Before Use.	9		
During Use.	9		
After Use	9		
Installation	11-12		
Maintenance	13-14		
Disassemble and Assemble			
Tandem Remote Control Valve.	13-14		

Definition of Terms

DANGER

This is an example of danger. This indicates an imminently hazardous situation which, if not avoided, will result in death or serious injury.

CAUTION

This is an example of a caution. This indicates a potentially hazardous situation which, if not avoided, may result in minor or moderate injury. It can also be used to alert against unsafe practices.

WARNING

This is an example of a warning. This indicates a potentially hazardous situation which, if not avoided, could result in death or serious injury.

NOTICE

This is an example of a notice. This indicates policy or practice directly related to safety of personnel or protection of property.

HAZARD IDENTIFICATIONS

WARNING

- ▶ Breathing dust containing silica could cause silicosis, a fatal lung disease. Breathing dust during abrasive blasting operations, post-blast cleaning operations, and/or servicing equipment within the abrasive blasting area may expose an individual to conditions that could cause asbestosis, lead poisoning and/or other serious or fatal diseases. Harmful dust containing toxic material from abrasives or surfaces being abrasive blasted can remain suspended in the air for long periods of time after abrasive blasting has ceased. A NIOSH-approved, well-maintained, respirator designed for the specific operation being performed must be used by anyone abrasive blasting, handling or using the abrasive, and anyone in the area of the dust.
- ▶ Contact NIOSH and OSHA offices to determine the proper respirator for your specific application. The air supplied to the respirator must be at least Grade D quality as described in Compressed Gas Association Commodity Specification G-7.1 and as specified by OSHA Regulation 1910.134. Ensure air filter and respirator system hoses are not connected to non-air sources or in-plant lines that may contain nitrogen, oxygen, acetylene or other non-breathable gases. Before removing respirator, use an air monitoring instrument to determine if the atmosphere is safe to breathe.
- ▶ You must comply with all OSHA, local, City, State, Province, Country and jurisdiction regulations, ordinances and standards, related to your particular work area and environment. Keep unprotected individuals out of the work area.
- ▶ Abrasive blasting operators must receive thorough training on the use of abrasive resistant attire which includes: supplied-air respirator, abrasive blasting suit, safety shoes, gloves, ear protection and eye protection. Protect the operator and bystanders by complying with NIOSH and OSHA Safety Standards.
- ▶ Inspect all equipment for wear or damage before and after each use. Failure to use Original Equipment Manufacturer repair parts and failure to immediately replace worn or damaged components could void warranties and cause malfunctions.
- ▶ OSHA requires abrasive blasting nozzles be equipped with an operating valve, which shall be designed to be held open only by continuous hand pressure and shall close immediately upon release of hand pressure (i.e., a “deadman” control). The valve shall not be modified in any manner that would allow it to remain open without the application of continuous hand pressure by the operator. Failure to comply with the above warning could result in release of high speed abrasive and compressed air resulting in death or serious injury. OSHA 29CFR 1910.244(b)
- ▶ Point the abrasive blasting nozzle only at the surface being abrasive blasted. Never point the abrasive blasting nozzle or abrasive stream at yourself or others.
- ▶ Unless otherwise specified, maximum working pressure of abrasive blasting pots and related components must not exceed 125 psi. Exceeding maximum working pressure of 125 psi could cause the abrasive blasting pot and components to burst. Failure to comply with the above warning could result in death or serious injury.
- ▶ Never weld, grind or drill on the abrasive blasting pot (or any pressure vessel). Doing so will void ASME certification and manufacturer’s warranty. Welding, grinding or drilling on the abrasive blasting pot (or any pressure vessel) could weaken the vessel causing it to burst. Failure to comply with the above warning could result in death or serious injury. (ASME Pressure Vessel Code, Section VIII, Division 1)
- ▶ This equipment is not intended for use in any area that might be considered a hazardous location, as described in the National Electric Code NFPA 70, Article 500. Use of this equipment in a hazardous location could cause an explosion or electrocution.
- ▶ Never hang objects from the abrasive blasting pot handle. Doing so may cause the abrasive blasting pot to become unstable and tip over.
- ▶ Never attempt to move an abrasive blasting pot containing abrasive. Never attempt to manually move abrasive blasting pots greater than 6.5 cubic foot capacity. Always use at least two capable people to manually move an abrasive blasting pot on flat, smooth surfaces. A mechanical lifting device must be used if an abrasive blasting pot is moved in any other manner.
- ▶ The use of this product for any purpose other than originally intended or altered from its original design is prohibited.

HAZARD IDENTIFICATIONS

WARNING

Failure to comply with ANY WARNING listed below could result in death or serious injury.

- ▶ This product is not for use in wet environments. Always use a Ground Fault Interrupter Circuit (GFIC) for all electrical power source connections. Use of this product in wet environments could create a shock or electrocution hazard.
- ▶ Frozen moisture could cause restrictions and obstructions in pneumatic control lines. Any restriction or obstruction in the pneumatic control lines could prevent the proper activation and deactivation of the remote control system, resulting in the release of high speed abrasive and compressed air. In conditions where moisture may freeze in the control lines an antifreeze injection system approved for this application can be installed.
- ▶ Do not cut, obstruct, restrict or pinch pneumatic control lines. Doing so could prevent the proper activation and deactivation of the remote control system, resulting in the release of high speed abrasive and compressed air.
- ▶ Use of Marco remote control switches with other manufacturer's remote control systems could cause unintended activation of remote control systems resulting in the release of high speed abrasive and compressed air. Only Marco remote control switches should be used with Marco remote control systems.
- ▶ Always be certain to have secure footing when abrasive blasting. There is a recoil hazard when abrasive blasting starts that may cause user to fall and misdirect the abrasive stream at operator or bystander.
- ▶ Never use an abrasive blasting pot or attachments as a climbing device. The person could slip and fall. The abrasive blasting pot could become unstable and tip over.
- ▶ For equipment manufactured by entities other than Marco, you must consult the Original Equipment Manufacturer operator's manuals, information, training, instructions and warnings, for the proper and intended use of all equipment.
- ▶ Flammable fumes, such as solvent and paint fumes in the work area can present an ignition or explosion hazard if allowed to collect in adequate concentrations. To reduce conditions that could result in a fire or an explosion, provide adequate ventilation, eliminate all ignition or spark sources, keep the work area free of debris, store solvents and solvent contaminated rags in approved containers, follow proper grounding procedures, do not plug/unplug power cord or turn on/off power switches when flammable fumes are present, keep a working fire extinguisher or provide another fire suppression system in the work area. Cease all operations and correct condition if a spark or ignition source is identified during operation.
- ▶ Always depressurize the entire system, disconnect all power sources and lockout/tagout all components before any maintenance or troubleshooting is attempted. Failure to comply with the above warning could cause electrical shock and inadvertent activation of equipment resulting in death or serious injury.
- ▶ Moving parts can present an area where crushing, pinching, entanglement or amputation may occur. Do not place body parts or foreign objects in any area where there are moving parts.
- ▶ Surfaces of heated supply tanks, drums and/or lines as well as the adjoining plumbing may become hot during normal use. Do not touch these heated surfaces without proper protection. Deactivate and allow sufficient time for all surfaces to cool before attempting any maintenance.
- ▶ High-pressure fluid from gun, hose leaks, or ruptured components can pierce skin and can cause a serious injury that may result in amputation. Do not point gun or spray tip at anyone or at any part of the body. Keep clear of any leaks or ruptures. Depressurize the entire system before attempting cleaning, inspecting, or servicing equipment.
- ▶ Exposure to toxic fluids or fumes may occur during the normal operation of this system. Before attempting to fill, use, or service this system, read MSDS's to know the specific hazards of the fluids you are using. Always use proper Personal Protective Equipment when attempting to fill, use, or service this system.

HAZARD IDENTIFICATIONS

CAUTION

Failure to comply with ANY CAUTION listed below may result in minor or moderate injury.

- ▶ Static electricity can be generated by abrasive moving through the abrasive blasting hose causing a shock hazard. Prior to use, ground the abrasive blasting pot and abrasive blasting nozzle to dissipate static electricity.
- ▶ High decibel noise levels are generated during the abrasive blasting process which may cause loss of hearing. Ensure appropriate Personal Protective Equipment and hearing protection is in use.

NOTICE

Failure to comply with ANY NOTICE listed below could pose a hazard to personnel or property.

- ▶ See Air & Abrasive Chart for estimated abrasive consumption rates and required air flow (cubic feet per minute). Your system must meet these minimum requirements to ensure proper function and performance.
- ▶ Always use abrasive that is dry and properly screened. This will reduce the potential for obstructions to enter the remote control system, abrasive metering valve and abrasive blasting nozzle.
- ▶ Moisture build-up occurs when air is compressed. Any moisture within the abrasive blasting system will cause abrasive to clump, clogging metering valves, hoses and nozzles. Install an appropriately sized moisture separator at the inlet of the abrasive blasting system. Leave the moisture separator petcock slightly open to allow for constant release of water. If insufficient volume of air exists and petcock is unable to be left open (at all times) petcock should be opened frequently to release water.
- ▶ To reduce abrasive intrusion in the air supply hose, depressurize the abrasive blasting pot before shutting off air supply from compressor.
- ▶ Inspect abrasive blasting nozzle before placing into service. Damage to abrasive blasting nozzle liner or jacket may occur during shipping. If you receive a damaged abrasive blasting nozzle, contact your distributor immediately for replacement. Abrasive blasting nozzles placed into service may not be returned. Abrasive blasting nozzle liners are made of fragile materials and can be damaged by rough handling and striking against hard surfaces. Never use a abrasive blasting nozzle.
- ▶ Abrasive blasting at optimal pressure for the abrasive used is critical to productivity. Example: For an abrasive with an optimal abrasive blasting pressure of 100 psi at the abrasive blasting nozzle, one pound per square inch of pressure loss will reduce abrasive blasting efficiency by 1.5%. A 10 psi reduction in air pressure will cause a 15% loss of efficiency. Use a Needle Pressure Gauge to identify pressure drops in your system. Consult with your abrasive supplier for the requirements of your abrasive.
- ▶ Replace abrasive blasting nozzle if liner or jacket is cracked or damaged. Replace abrasive blasting nozzle if original orifice size has worn 1/16" or more. Determine abrasive blasting nozzle wear by inserting a drill bit 1/16" larger than original size of abrasive blasting nozzle orifice. If the drill bit passes through abrasive blasting nozzle, replacement is needed.

AIR & ABRASIVE CONSUMPTION CHART

NOTICE

Failure to comply with ANY NOTICE listed below could pose a hazard to personnel or property.

- ▶ See Air & Abrasive Chart for estimated abrasive consumption rates and required air flow (cubic feet per minute). Your system must meet these minimum requirements to ensure proper function and performance.
- ▶ When it comes to air & abrasive mixtures, more is not necessarily better. Optimum abrasive blasting efficiency takes place when a lean air & abrasive mixture is used. To correctly set the abrasive metering valve, begin with the valve fully closed and slowly increase the amount of abrasive entering the airstream. As you increase the abrasive flow, watch for a “blue flame” at the exit of the abrasive blasting nozzle. Faster cutting, reduced abrasive consumption and lower clean up costs, are benefits of the “blue flame”.
- ▶ Abrasive blasting at optimal pressure for the abrasive used is critical to productivity. Example: For an abrasive with an optimal abrasive blasting pressure of 100 psi at the abrasive blasting nozzle, one pound per square inch of pressure loss will reduce abrasive blasting efficiency by 1.5%. A 10 psi reduction in air pressure will cause a 15% loss of efficiency. Use a Needle Pressure Gauge to identify pressure drops in your system. Consult with your abrasive supplier for the requirements of your abrasive.

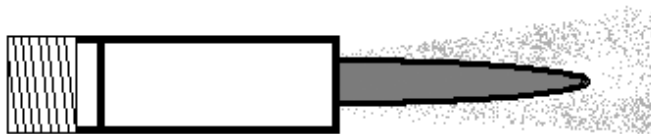

Figure 1

NOTICE

Inspect abrasive blasting nozzle before placing into service. Damage to abrasive blasting nozzle liner or jacket may occur during shipping. If you receive a damaged abrasive blasting nozzle, contact your distributor immediately for replacement. Abrasive blasting nozzles placed into service may not be returned. Abrasive blasting nozzle liners are made of fragile materials and can be damaged by rough handling and striking against hard surfaces. Never use a abrasive blasting nozzle.

Air & Abrasive Consumption Chart*

Nozzle Orifice	Pressure at the Nozzle (PSI)								Air (in cfm), Abrasive & Compressor Requirements
	50	60	70	80	90	100	125	140	
No. 2 (1/8")	11	13	15	17	18	20	25	28	Air (cfm)
	67	77	88	101	112	123	152	170	Abrasive (lbs/hr)
	2.5	3	3.5	4	4.5	5	5.5	6.2	Compressor Horsepower
No. 3 (3/16")	26	30	33	38	41	45	55	62	Air (cfm)
	150	171	196	216	238	264	319	357	Abrasive (lbs/hr)
	6	7	8	9	10	10	12	13	Compressor Horsepower
No. 4 (1/4")	47	54	61	68	74	81	98	110	Air (cfm)
	268	312	354	408	448	494	608	681	Abrasive (lbs/hr)
	11	12	14	16	17	18	22	25	Compressor Horsepower
No. 5 (5/16")	77	89	101	113	126	137	168	188	Air (cfm)
	468	534	604	672	740	812	982	1100	Abrasive (lbs/hr)
	18	20	23	26	28	31	37	41	Compressor Horsepower
No. 6 (3/8")	108	126	143	161	173	196	237	265	Air (cfm)
	668	764	864	960	1052	1152	1393	1560	Abrasive (lbs/hr)
	24	28	32	36	39	44	52	58	Compressor Horsepower
No. 7 (7/16")	147	170	194	217	240	254	314	352	Air (cfm)
	896	1032	1176	1312	1448	1584	1931	2163	Abrasive (lbs/hr)
	33	38	44	49	54	57	69	77	Compressor Horsepower
No. 8 (1/2")	195	224	252	280	309	338	409	458	Air (cfm)
	1160	1336	1512	1680	1856	2024	2459	2754	Abrasive (lbs/hr)
	44	50	56	63	69	75	90	101	Compressor Horsepower
No. 10 (5/8")	308	356	404	452	504	548	663	742	Air (cfm)
	1875	2140	2422	2690	2973	3250	3932	4405	Abrasive (lbs/hr)
	68.5	79.5	90	100.5	112	122	146	165	Compressor Horsepower
No. 12 (3/4")	432	504	572	644	692	784	948	1062	Air (cfm)
	2672	3056	3456	3840	4208	4608	5570	6238	Abrasive (lbs/hr)
	96	112	127	143	154	174.5	209	236	Compressor Horsepower

*Abrasive consumption is based on abrasive with a bulk density of 100 lbs per Cubic Foot

NOTICE

Replace abrasive blasting nozzle if liner or jacket is cracked or damaged. Replace abrasive blasting nozzle if original orifice size has worn 1/16" or more. Determine abrasive blasting nozzle wear by inserting a drill bit 1/16" larger than original size of abrasive blasting nozzle orifice. If the drill bit passes through abrasive blasting nozzle, replacement is needed.

"THE BIG PICTURE"

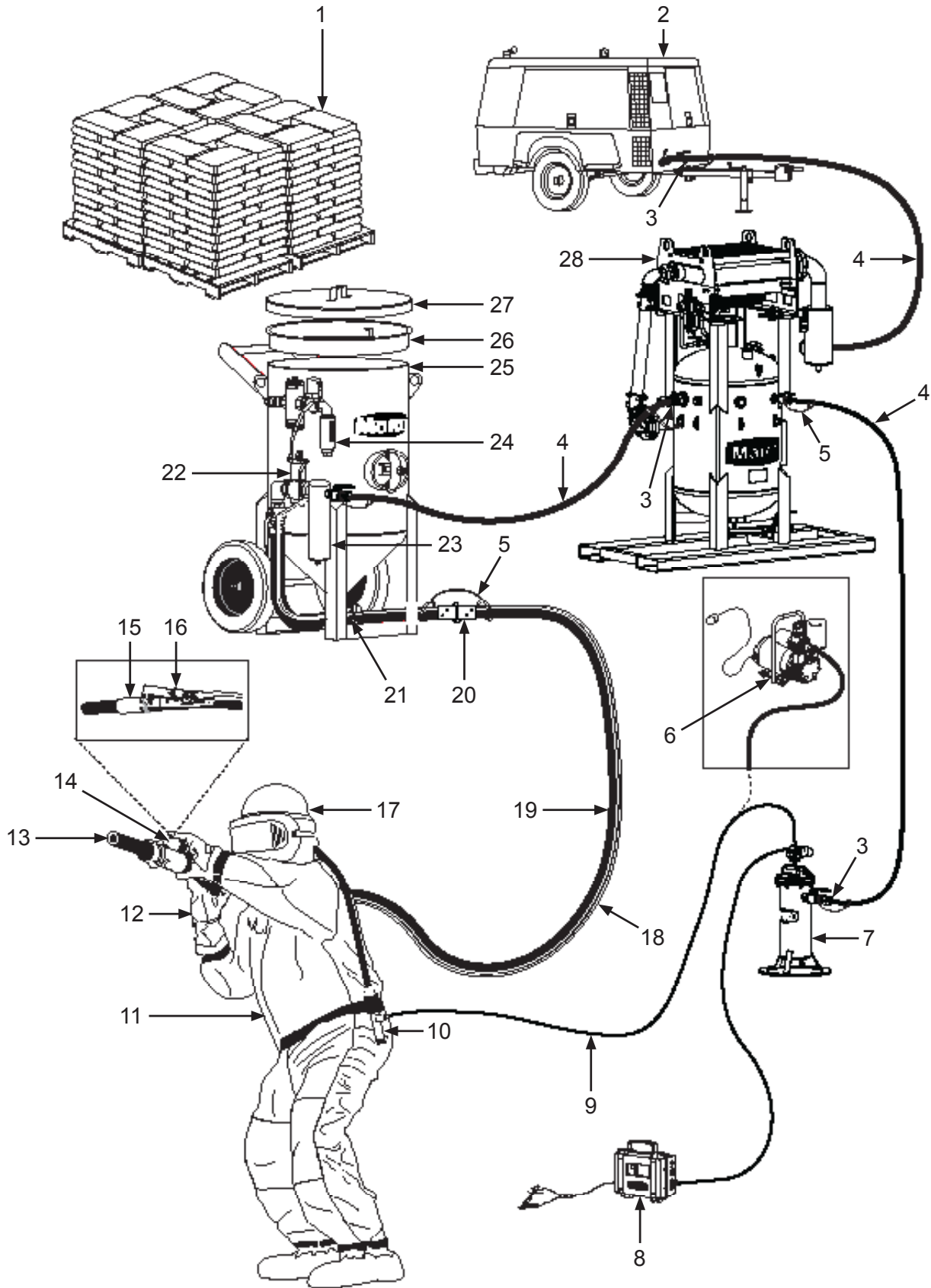

DAILY PRE-OPERATION CHECKLIST

Daily Pre-operation Checklist

- 1. Abrasive
- 2. Air Compressor
- 3. Air Hose Couplings & Gaskets
- 4. Air Hose
- 5. Safety Cable
- 6. Ambient Air Pump*
- 7. Breathing Air Filter
- 8. CO Monitor
- 9. Breathing Line
- 10. Climate Control Device
- 11. Abrasive Blasting Suit
- 12. Gloves
- 13. Abrasive Blasting Nozzle
- 14. Lighting System*
- 15. Abrasive Blasting Nozzle Holder
- 16. Remote Control Switch
- 17. Supplied-Air Respirator
- 18. Control Line
- 19. Abrasive Blasting Hose
- 20. Abrasive Blasting Hose Couplings & Gaskets
- 21. Abrasive Metering Valve
- 22. Remote Control System
- 23. Moisture Separator
- 24. Abrasive Blasting Pot Exhaust Muffler
- 25. Abrasive Blasting Pot
- 26. Abrasive Blasting Pot Screen
- 27. Abrasive Blasting Pot Lid
- 28. Aftercooler*

* *Optional or alternative device. Ask your Marco Representative for more details.*

Abrasive – Select the correct Abrasive (1) for the application. Review the MSDS (*Material Safety Data Sheet*) to ensure the correct PPE (*Personal Protective Equipment*) and Environmental Controls have been selected and are in place.

Air Compressor – Select an Air Compressor (2) of adequate size to support all equipment requirements. Refer to “Air & Abrasive Consumption Chart” for Abrasive Blasting Nozzle (13) air consumption requirements. Before connecting Air Hose (4), sample the air being produced by the air compressor (2) to ensure it is free of petroleum contaminants.

Air Hose, and Air Hose Couplings & Gaskets – Select Air Hoses (4) of sufficient size to support all subsequent volumetric requirements and with a sufficient PSI (*pound per square inch*) rating. Inspect all Air Hose (4), and Air Hose Couplings & Gaskets (3) for damage or wear. Repair or replace damaged or worn components.

Abrasive Blasting Hose, Abrasive Blasting Hose Couplings & Gaskets, and Abrasive Blasting Nozzle Holder – Select an Abrasive Blasting Hose (19) that has an inner diameter 3 to 4 times larger than your Abrasive Blasting Nozzle (13). Inspect Abrasive Blasting Hose (19), Abrasive Blasting Hose Couplings & Gaskets (20), and Abrasive Blasting Nozzle Holder (15) for damage or wear. Repair or replace damaged or worn components.

Safety Cables – Install a Safety Cable (5) at each Abrasive Blasting Hose (19), and Air Hose (4) connection points.

Aftercooler and Moisture Separator – Ensure Aftercooler (28) is positioned on stable ground. Keep petcock drain of Moisture Separator (23) slightly open during use. Drain both devices after each use.

Supplied-Air Respirator, Breathing Line, Breathing Air Filter, Climate Control Device, CO Monitor, Ambient Air Pump – You MUST consult the Operator’s Manual supplied with your Respiratory Equipment (6, 7, 8, 9, 10, 17) for ALL applicable instructions and warnings. Inspect all Respiratory Equipment components for damage or wear. Repair or replace damaged or worn components.

Abrasive Blasting Suit and Gloves – Select an abrasive-resistant Abrasive Blasting Suit (11) that is slightly oversized to allow ease of movement and allows air to flow around your body. Select abrasive-resistant Gloves (12) with a tight fit and a long cuff that overlaps the sleeve of the Abrasive Blasting Suit (11).

Abrasive Metering Valve and Abrasive Blasting Pot – Confirm Abrasive Blasting Pot (25) is positioned on stable ground. Inspect Abrasive Blasting Pot (25) and Abrasive Metering Valve (21) for damage or wear. Repair or replace damaged or worn components.

Abrasive Blasting Pot Screen and Abrasive Blasting Pot Lid – Always use an Abrasive Blasting Pot Screen (26) when filling Abrasive Blasting Pot (25) with Abrasive (1) to prevent debris from entering the Abrasive Blasting Pot (25). Remove Abrasive Blasting Pot Lid (27) before operating the Abrasive Blasting Pot (25). Install Abrasive Blasting Pot Lid (27) after use to protect the Abrasive Blasting Pot’s (25) interior.

Remote Control System, Remote Control Switch, Control Line, – Inspect Remote Control System (22) and Control Line (18) for damage or wear. Repair or replace damaged or worn components. Ensure Control Line (18) fittings connected to the Remote Control System (22) are tight and free of leaks. Ensure Remote Control Switch (16) is functioning properly. Consult Remote Control Switch Operator’s Manual for applicable instructions.

Abrasive Blasting Pot Exhaust Muffler – Inspect Abrasive Blasting Pot Exhaust Muffler (24) at start and end of daily use. Replace element of Abrasive Blasting Pot Exhaust Muffler (24) per Operator’s Manual instructions.

Lighting System – Ensure the Lighting System (14) is connected to a proper power supply before use.

⚠ WARNING

Always depressurize the entire system, disconnect all power sources and lockout/tagout all components before any maintenance or troubleshooting is attempted. Failure to comply with the above warning could cause electrical shock and inadvertent activation of equipment resulting in death or serious injury.

⚠ WARNING

OSHA requires blast-cleaning nozzles be equipped with an operating valve, which shall be designed to be held open only by continuous hand pressure and shall close immediately upon release of hand pressure (i.e., a "deadman" control). The valve shall not be modified in any manner that would allow it to remain open without the application of continuous hand pressure by the operator. Failure to comply with the above warning could result in release of high speed abrasive and compressed air resulting in death or serious injury. OSHA 29CFR 1910.244(b)

⚠ WARNING

For equipment manufactured by entities other than Marco, you must consult the Original Equipment Manufacturer operator's manuals, information, training, instructions and warnings, for the proper and intended use of all equipment. Failure to comply with the above warning could result in death or serious injury.

Description

Remote control systems give an operator the ability to remotely activate and deactivate the flow of air and abrasive at the nozzle. Pressure-release remote control systems pressurize and depressurize the abrasive blasting pot each time the operator activates and deactivates the remote control switch, allowing for the abrasive blasting pot to be filled between activation cycles. This increases productivity and eliminates the need for a pot tender. The Blastmaster® 123P Remote Control System is a pressure-release remote control system that uses a pneumatic signal from the remote control switch to remotely activate and deactivate an abrasive blasting pot. Typical applications include blast rooms, blast yards, bridges, oil refineries, pipelines, railcar shops, shipyards, and storage tanks.

Operational Requirements

The following is required for proper installation of a Blastmaster® 123P Remote Control System:

- An abrasive blasting pot with an air inlet and air exhaust outlet of 1" I.D. or greater.

The following may cause safety hazards or reduced performance:

- Improper installation and/or maintenance of components
- Improper air supply pressure (operating pressure: 50–150 PSI)
- Use of pneumatic twinline hose greater than 100 feet in length

Operating Instructions

Fig. 2

Before using:

- Inspect Blastmaster® 123P Remote Control System components for damage and air leaks. Repair or replace damaged components before use.
- Test Pneumatic Remote Control Switch (5) for proper functioning. (See pneumatic remote control switch Operator's Manual.)
- Ensure abrasive blasting pot is depressurized. (See abrasive blasting pot Operator's Manual.)
- Connect air supply from compressor to Inlet Port (3).
- Connect Pneumatic Control Line (4) to Tandem Remote Control Valve (2).
- Connect Pneumatic Remote Control Switch (5) to Pneumatic Control Line (4).

During use:

- To begin abrasive blasting, activate the Pneumatic Remote Control Switch (5), this will complete an air circuit to the Tandem Remote Control Valve (2), to begin pressurizing the abrasive blasting pot.
- Monitor all components of the Blastmaster® 123P Remote Control System for proper functioning.
- To cease abrasive blasting, deactivate the Pneumatic Remote Control Switch (5), this will interrupt the air circuit, allowing the abrasive blasting pot to depressurize.
- Inspect Blowdown Hose Assembly (1) at least twice daily for damage. Repair or replace damaged components.

After use:

- Inspect components of the Blastmaster® 123P Remote Control System for damage. Repair or replace damaged components.

OPERATING INSTRUCTIONS

Figure 2

CAUTION

High decibel noise levels are generated during the abrasive blasting process which may cause loss of hearing. Ensure appropriate Personal Protective Equipment and hearing protection is in use. Failure to comply with the above caution may result in minor or moderate injury.

CAUTION

Release of high speed abrasive and compressed air occurs during depressurization of the abrasive blasting pot. Ensure appropriate Personal Protective Equipment is in use. Failure to comply with the above caution may result in minor or moderate injury.

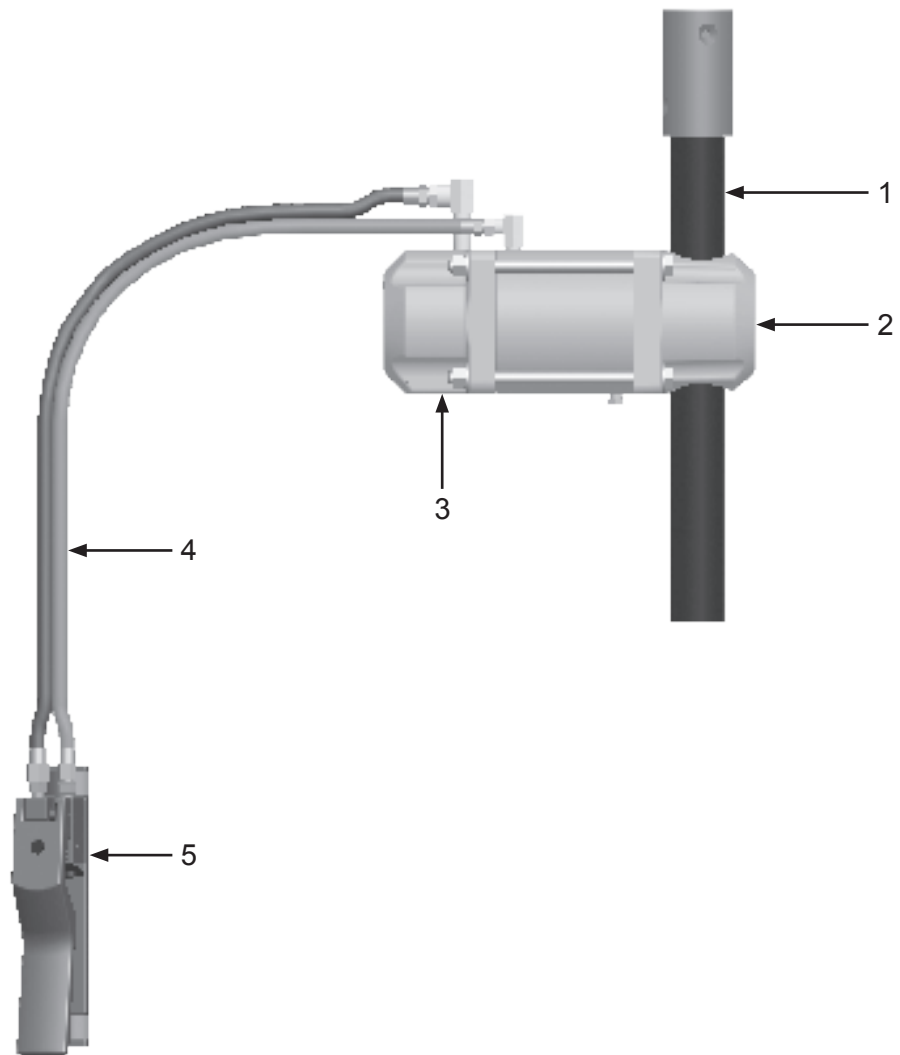

INSTALLATION

WARNING

Inspect all equipment for wear or damage before and after each use. Failure to use Original Equipment Manufacturer repair parts and failure to immediately replace worn or damaged components could void warranties and cause malfunctions. Failure to comply with the above warning could result in death or serious injury.

WARNING

Moving parts can present an area where crushing, pinching, entanglement or amputation may occur. Do not place body parts or foreign objects in any area where there are moving parts. Failure to comply with the above warning could result in death or serious injury.

Installation

Fig. 3

NOTE: Additional piping may be required to install the Blastmaster® 123P Remote Control System.

- 1) Install Air Outlet Port (7) of Tandem Remote Control Valve (5) on inlet piping of abrasive blasting pot.
- 2) Insert Blowdown Hose Assembly (4) in Tandem Remote Control Valve (5).
- 3) Install Blowdown Hose Assembly (4) on outlet piping of abrasive blasting pot.
- 4) Connect Leg A (1) of Pneumatic Control Line (9) to Fitting (2).
- 5) Connect Leg B (8) of Pneumatic Control Line (9) to Fitting (3).
- 6) Connect Pneumatic Remote Control Switch (10) to Pneumatic Control Line (9). (See pneumatic remote control switch Operator's Manual.)
- 8) Connect air inlet piping in Air Inlet Port (6) of Tandem Remote Control Valve (5).

INSTALLATION

Figure 3

WARNING

Always depressurize the entire system, disconnect all power sources and lockout/tagout all components before any maintenance or troubleshooting is attempted. Failure to comply with the above warning could cause electrical shock and inadvertent activation of equipment resulting in death or serious injury.

WARNING

For equipment manufactured by entities other than Marco, you must consult the Original Equipment Manufacturer operator's manuals, information, training, instructions and warnings, for the proper and intended use of all equipment. Failure to comply with the above warning could result in death or serious injury.

NOTICE

Apply pipe thread sealant to all pipe threads to ensure an airtight seal.

NOTICE

Pulling and dragging abrasive blasting hose may cause pneumatic control line connections to separate. Connect the pneumatic control line to the abrasive blasting hose every 4 to 6 feet and on each side of the pneumatic control line connections. Provide adequate slack at each connection.

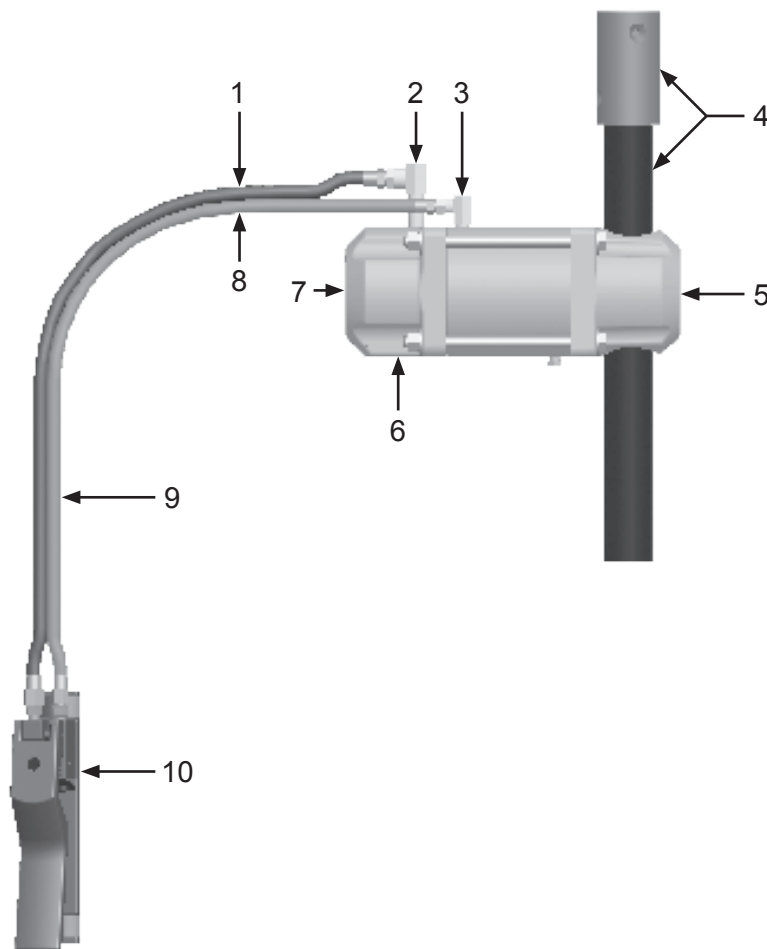

MAINTENANCE

Disassemble and Assemble Tandem Remote Control Valve

WARNING

Always depressurize the entire system, disconnect all power sources and lockout/tagout all components before any maintenance or troubleshooting is attempted. Failure to comply with the above warning could cause electrical shock and inadvertent activation of equipment resulting in death or serious injury.

WARNING

Never use compressed air to separate or remove internal components during maintenance. Components could be ejected at high speeds. Failure to comply with the above warning could result in death or serious injury.

WARNING

Moving parts can present an area where crushing, pinching, entanglement or amputation may occur. Do not place body parts or foreign objects in any area where there are moving parts. Failure to comply with the above warning could result in death or serious injury.

WARNING

The Tandem Remote Control Valve base (p/n) 1012321 has an integrated restrictor port to limit the volume of supplied air to the remote control switch. Failure to use original manufacturer repair parts will void warranties, cause malfunctions and could result in uncontrolled release of high speed abrasive and compressed air. Failure to comply with the above warning could result in death or serious injury.

Maintenance of the Tandem Remote Control Valve is limited to the daily cleaning and the immediate replacement of damaged or worn parts.

Disassemble:

Fig. 4

- 1) Remove Swivel Fittings (3 and 11).
- 2) Remove Breather Muffler (22).
- 3) Remove four Bolts (26), Washers (25), Nuts (12), and Washers (13) in a cross pattern.
- 4) Remove Base (14) and Cap (24). Note orientation of Cap when removing.
- 5) Remove Lower Rod O-ring (17).
- 6) Remove Nut (10), Washer (15), two O-rings (9), and Valve Plug (16) from Shaft (19).
- 7) Remove Lower Rod Guide (8) from Shaft (19).
- 8) Gently remove Pinch Ram (23) from Cylinder (21).
- 9) Insert a tool in Hole (D), and remove Spring (20) from Shaft (19) by grasping Pinch Ram (23) and turning it counter-clockwise. Remove Pinch Ram (23) from Shaft. NOTE: Spring is under tension. Do not remove Snap Ring (6) before Spring is removed.
- 10) Remove Upper Rod Guide (2) and Spring (20) from Shaft (19).
- 11) Remove Snap Ring (6), Piston (18) and O-ring (4) from Shaft (19).
- 12) Remove U-cup (5) from Piston (18).
- 13) Remove Seal (1) from Upper Rod Guide (2).
- 14) Remove U-cup (7) from Lower Rod Guide (8).
- 15) Clean and inspect all parts for damage. Replace damaged parts as necessary.

Assemble:

- 1) Install O-ring (4) in wide groove of Shaft (19).
- 2) Place Piston Seal (5) on Piston (18).
- 3) Apply white lithium grease to O-ring (4), and install Piston (18) onto Shaft (19). Install Snap Ring (6). Ensure "flat" side of the Piston is facing the male threads on Shaft.
- 4) Install Upper Rod Guide Seal (1) into Upper Rod Guide (2) as shown. Apply white lithium grease to inner diameter of Upper Rod Guide Seal.
- 5) Install Spring (20), and Upper Rod Guide (2) on Shaft (19).
- 6) Compress Spring (20) until Shaft (19) protrudes through Upper Rod Guide (2) and install Pinch Ram (23) in Shaft.
- 7) Place Cylinder (21) on flat surface with tapered inner diameter facing up.
- 8) Lubricate outer surface of Piston Seal (5) using white lithium grease. Insert Shaft Assembly into Cylinder (21) until Upper Rod Guide (2) fully seats in Cylinder.
- 9) Install Seal (7), as shown, in Lower Rod Guide (8). Place Lower Rod Guide on Shaft (19) with flat side toward Piston (18).
- 10) Install Valve Plug (16) on Shaft (19). Install two O-rings (9) on Shaft and seat in recess of Valve Plug. Install Washer (15) and Nut (10) on Shaft.
- 11) Place Cap (24) over Pinch Ram (23) and seat Cap against Cylinder (21). Ensure Blow Down Assembly Port (A) is aligned with Control Line Port (B) on top of Cylinder. and Pinch Ram (23) seats in internal grooves in Cap. Place Washer (25) on Bolt (26) and install in Cap. Repeat for remaining three washers and bolts.
- 12) Place O-Ring (17) on Lower Rod Guide (8), and install Base (14) over Valve Plug (16). Ensure Control Line Port (C) is aligned with Control Line Port (B).
- 13) Insert Bolt (26) through Base (14), and install Washer (13) and Nut (12) on Bolt. Repeat for remaining three washers and nuts. Tighten Nuts in a cross pattern.
- 14) Install 1/8" Breather Vent (22), in port closest to Pinch Ram (23).
- 15) Install 1/4" Swivel Fitting (11) in Control Line Port (C) and 1/8" Swivel Fitting (3) in Control Line Port (A).

MAINTENANCE

Figure 4

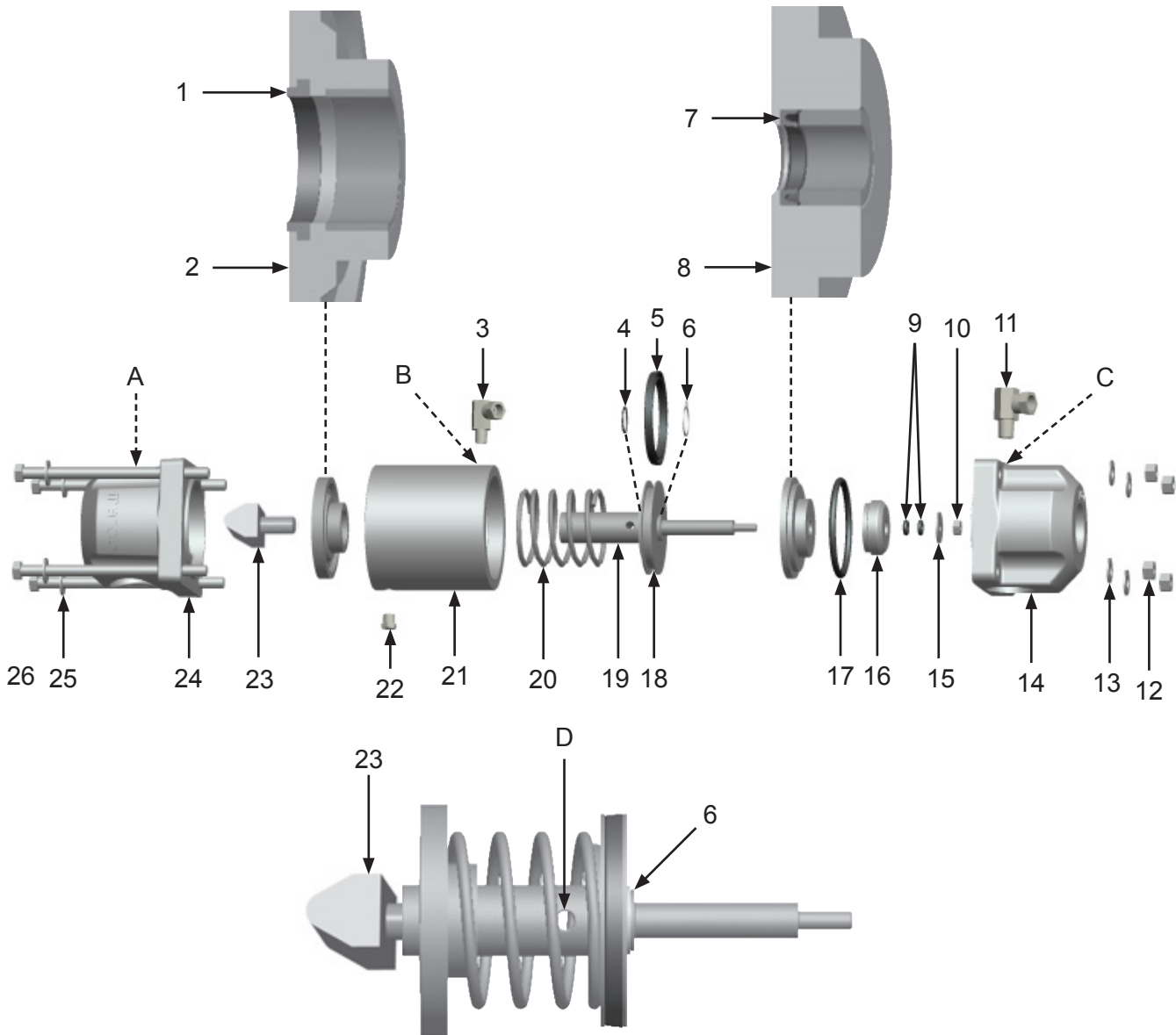

TROUBLESHOOTING

If the Blastmaster® 123P Remote Control System does not function properly, check the following:

WARNING

Always depressurize the entire system, disconnect all power sources and lockout/tagout all components before any maintenance or troubleshooting is attempted. Failure to comply with the above warning could cause electrical shock and inadvertent activation of equipment resulting in death or serious injury.

WARNING

Do not cut, obstruct, restrict or pinch pneumatic twinline or single line hoses. Doing so could prevent the proper activation and deactivation of the remote control system, resulting in the release of high speed abrasive and compressed air. Failure to comply with the above warning could result in death or serious injury.

WARNING

Frozen moisture could cause restrictions and obstructions in pneumatic twinline or single line hoses. Any restriction or obstruction in the pneumatic twinline or single line hoses could prevent the proper activation and deactivation of the remote control system, resulting in the release of high speed abrasive and compressed air. In conditions where moisture may freeze in the pneumatic twinline or single line hoses an antifreeze injection system approved for this application can be installed. Failure to comply with the above warning could result in death or serious injury.

SYMPTOM (Cause)

Abrasive blasting pot will not pressurize

(Damaged components, Pneumatic control line, Improper air supply)

ACTION

Inspect pneumatic control lines for correct routing, air leaks, blockage or pinch points. Tighten control line fittings if leaks are present. Replace damaged pneumatic control lines.

1/8" Breather Muffler. Remove 1/8" Breather Muffler, and attempt to pressurize abrasive blasting pot. If abrasive blasting pot pressurizes, replace 1/8" Breather Muffler.

Observe Pinch Ram clamping on Blowdown Hose. If Pinch Ram does not fully clamp on Blowdown Hose, inspect Tandem Remote Control Valve for damage. Repair or replace damaged components.

Inspect Blowdown Hose Assembly for leaks. Replace Blow Down Assembly.

Insufficient air supply. Ensure minimum of 50 PSI is supplied to the Tandem Remote Control Valve.

See Operator's Manual for the remote control switch, and abrasive blasting pot.

Inconsistent activation/deactivation

(Improper air supply, Damaged components, Pneumatic control lines)

Inspect pneumatic control lines for correct routing, air leaks, blockage or pinch points. Tighten control line fittings if leaks are present. Replace damaged pneumatic control lines.

Insufficient air supply. Ensure minimum of 50 PSI is supplied to the Tandem Remote Control Valve.

Inspect Tandem Remote Control Valve for damage. Repair or replace as necessary.

See Operator's Manual for the remote control switch, and abrasive blasting pot.

TROUBLESHOOTING

WARNING

Always depressurize the entire system, disconnect all power sources and lockout/tagout all components before any maintenance or troubleshooting is attempted. Failure to comply with the above warning could cause electrical shock and inadvertent activation of equipment resulting in death or serious injury.

WARNING

Do not cut, obstruct, restrict or pinch pneumatic twinline or single line hoses. Doing so could prevent the proper activation and deactivation of the remote control system, resulting in the release of high speed abrasive and compressed air. Failure to comply with the above warning could result in death or serious injury.

If the Blastmaster® 123P Remote Control System does not function properly, check the following:

SYMPTOM (Cause)

Abrasive blasting pot will not depressurize or depressurizes slowly
(Damaged components, Pneumatic control line, obstruction in system exhaust)

ACTION

Inspect pneumatic control lines for correct routing, air leaks, blockage or pinch points. Tighten control line fittings if leaks are present. Replace damaged pneumatic control lines.

1/8" Breather Muffler. Remove 1/8" Breather Muffler, and attempt to depressurize abrasive blasting pot. If abrasive blasting pot depressurizes, replace 1/8" Breather Muffler.

Inspect Tandem Remote Control Valve for damage. Repair or replace as necessary.

Inspect Blowdown Hose Assembly for obstructions and damage. Replace Blowdown Assembly.

See Operator's Manual for the remote control switch, and abrasive blasting pot.

ASSEMBLY PART NUMBERS AND SCHEMATIC

Figure 6: Blastmaster® 123P Remote Control System

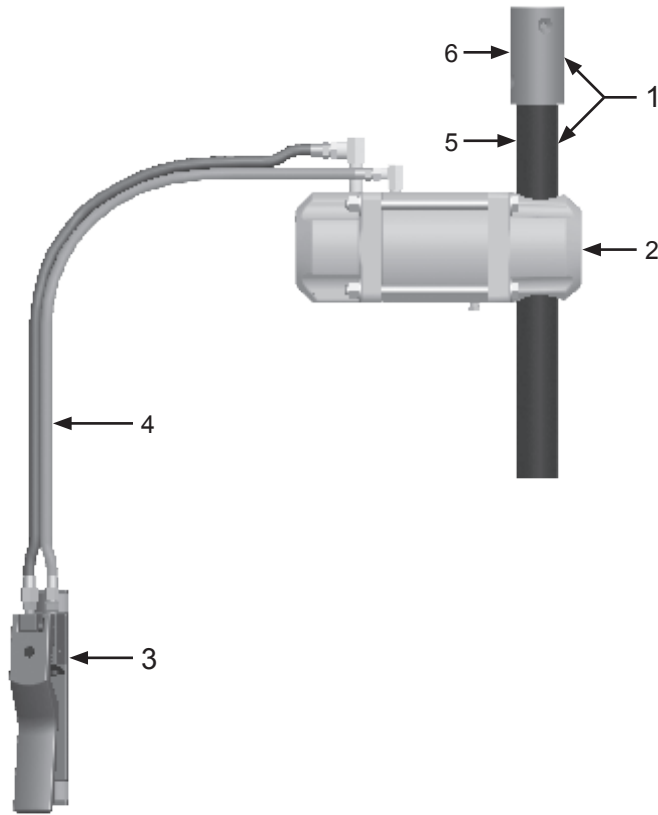

Item #	Part #	Description
Fig. 6		
—	1012351	Blastmaster® 123P Remote Control System – Complete
1	1012350	Blowdown Hose Assembly <i>(Includes Item #'s: 5 (Quantity of two feet) and 6)</i>
2	1012300	Tandem Remote Control Valve – Complete <i>(see Figure 7)</i>
3	1015200	Blastmaster® 152P Remote Control Switch
4	1016000	55 Feet of Coupled Control Line with 1/4" and 1/8" Fittings
5	10BH0342BR	3/4" I.D. Abrasive Blasting Hose <i>(sold per foot)</i>
6	10NHA1	1-1/4" Aluminum Nozzle Holder
—	106M007	Part Numbers & Schematics Guide – Blastmaster® 123P Remote Control System
—	106M068	Part Numbers & Schematics Guide – Blastmaster® 152P Remote Control Switch
—	1090007	Operator's Manual – Blastmaster® 123P Remote Control System
—	1090068	Operator's Manual – Blastmaster® 152 Remote Control Switch

ASSEMBLY PART NUMBERS AND SCHEMATIC

Figure 7: Tandem Remote Control Valve

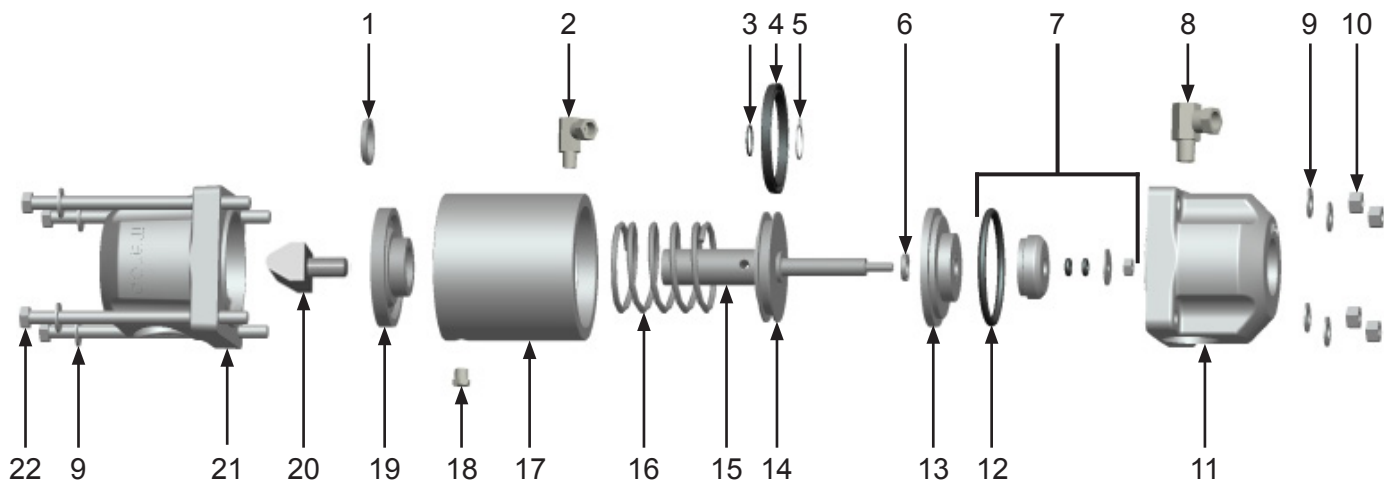

Item #	Part #	Description
Fig. 7		
—	1012300	Tandem Remote Control Valve – Complete
1	1012308	Seal – Upper Rod Guide
2	1014239	1/8" 90° Swivel Fitting
3	1012312	O-ring – Shaft
4	1012317	Seal – Piston
5	1012313	13/16" External Snap Ring
6	1012314	Seal – Lower Rod Guide
7	1012322	Valve Plug Assembly (<i>Includes Item #12</i>)
8	1012326	1/4" 90° Swivel Fitting
9	1014241	3/8" Washer (<i>Eight Required</i>)
10	1012318	3/8-16 Nut (<i>Four Required</i>)
11	1012321	Base
12	1012320	O-ring – Lower Rod Guide
13	1012319	Lower Rod Guide
14	1012315	Piston
15	1012316	Shaft
16	1012309	Spring
17	1012311	Cylinder
18	1012905	1/8" Breather Muffler
19	1012307	Upper Rod Guide
20	1012306	Pinch Ram
21	1012305	Cap
22	1012310	3/8-16 x 6" Bolt (<i>Four Required</i>)
—	1012301	Tandem Remote Control Valve Repair Kit (<i>Includes Item #'s: 1, 3–7, and 12</i>)
—	106M007	Part Numbers and Schematics Guide – Blastmaster® 123P Remote Control System
—	1090007	Operator's Manual – Blastmaster® 123P Remote Control System
—	1091045	Hazard Identification Tag

ADDITIONAL TECHNICAL DATA

The associations listed below offer information, materials and videos pertaining to abrasive blasting and safe operating practices.

- **American Society for Testing and Materials (ASTM)**
100 Barr Harbor Drive
West Conshohocken, PA 19428-2959
Phone: (610) 832-9585
FAX: (610) 832-9555
www.astm.org
- **Occupational Safety & Health Administration (OSHA)**
United States
Department of Labor
200 Constitution Avenue
Washington, DC 20210
Phone: (800) 321-OSHA
(800) 321-6742
www.osha.gov
- **The National Board of Boiler & Pressure Vessel Inspectors**
1055 Crupper Avenue
Columbus, Ohio 4322
Phone: (614) 888-8320
FAX: (614) 888-0750
www.nationalboard.org
- **National Association of Corrosion Engineers (NACE)**
1440 South Creek Drive
Houston, TX 77084-4906
Phone: (281) 228-6200
FAX: (281) 228-6300
www.nace.org
- **The Society for Protective Coatings (SSPC)**
40-24th Street, 6th Floor
Pittsburgh, PA 15222-4656
Phone: (412) 281-2331
FAX: (412) 281-9992
www.sspc.org
- **American National Standards Institute (ANSI)**
1899 L Street, NW, 11th Floor
Washington, DC 20036
Phone: (202) 293-8020
FAX: (202) 293-9287
www.ansi.org

LIMITED WARRANTY

Seller warrants to the original purchaser that the Product covered by this Limited Warranty will remain free from defects in workmanship or material under normal commercial use and service for a period of one year from the date of shipment to the original Purchaser. This Warranty shall not apply to defects arising, in whole or in part, from any accident, negligence, alteration, misuse or abuse of the Product, operation of the Product which is not in accordance with applicable instructions or manuals or under conditions more severe than, or otherwise exceeding, those set forth in the written specifications for the Product, nor shall this Warranty extend to repairs or alterations of the Product and/or any maintenance part by persons other than Seller or Seller's authorized representatives. This warranty does not apply to accessory items. Further, this Warranty does not apply to damage or wear to the surface finish or appearance of the Product or normal wear and tear to the Product. This Warranty is limited to a purchaser who purchases the Product either directly from the Seller or from one of Seller's "Authorized Distributors". An Authorized Distributor is a Seller approved distributor that purchases the Product directly from the Seller for the sole purpose of re-selling the Product at retail, without any use or modifications whatsoever, to an end-purchaser. This warranty is specifically non-assignable and non-transferable.

DISCLAIMER OF WARRANTY

The foregoing Limited Warranty is exclusive and is in lieu of all other warranties, whether oral or written and whether express, implied, or statutory. SELLER HEREBY DISCLAIMS ALL OTHER WARRANTIES, INCLUDING BUT NOT LIMITED TO THE WARRANTIES OF MERCHANTABILITY AND/OR FITNESS FOR A PARTICULAR PURPOSE AND ALL SUCH OTHER WARRANTIES ARE HEREBY EXCLUDED AND ARE INAPPLICABLE TO THE PRODUCT. Seller makes no warranties or representations of any kind concerning respirators, or equipment made by other manufacturers. Seller's agents and representatives are not authorized to offer any further warranties.

EXCLUSIVE REMEDY FOR WARRANTY CLAIMS

THE SOLE AND EXCLUSIVE REMEDY UNDER THE FOREGOING LIMITED WARRANTY, AND TO THE EXTENT PERMITTED BY LAW, ANY WARRANTY OR CONDITION IMPLIED BY LAW, COVERING THIS PRODUCT SHALL BE, AT THE SELLER'S OPTION, THE REPAIR OR REPLACEMENT, FREE OF CHARGE, F.O.B. POINT OF MANUFACTURE, OF ANY DEFECTIVE PART OR PARTS OF THE PRODUCT THAT WERE MANUFACTURED BY SELLER, AND WHICH ARE RETURNED TO SELLER AT SELLER'S PRINCIPAL PLACE OF BUSINESS, POSTAGE PREPAID BY THE PURCHASER. THIS SOLE AND EXCLUSIVE REMEDY IS CONDITIONED UPON PURCHASER'S PROMPT WRITTEN NOTICE TO SELLER AT SELLER'S PLACE OF BUSINESS THAT A DEFECT HAS BEEN DISCOVERED, TOGETHER WITH A REASONABLY DETAILED DESCRIPTION OF THE DEFECT IN THE PRODUCT, PROOF OF PURCHASE OF THE PRODUCT, AND THE MODEL AND IDENTIFICATION NUMBER OF THE PRODUCT WITHIN THIRTY (30) DAYS AFTER DISCOVERY OF THE DEFECT, OTHERWISE SUCH CLAIMS SHALL BE DEEMED WAIVED. NO ALLOWANCE WILL BE GRANTED FOR ANY REPAIRS OR ALTERATIONS MADE BY PURCHASER OR OTHERS WITHOUT SELLER'S PRIOR WRITTEN CONSENT. IF SUCH NOTICE IS TIMELY GIVEN, SELLER WILL HAVE THE OPTION TO EITHER MODIFY THE PRODUCT OR COMPONENT PART THEREOF TO CORRECT THE DEFECT, REPLACE THE PRODUCT OR PART WITH COMPLYING PRODUCTS OR PARTS, OR REFUND THE AMOUNT PAID FOR THE DEFECTIVE PRODUCT, ANY ONE OF WHICH WILL CONSTITUTE THE SOLE LIABILITY OF SELLER AND FULL SETTLEMENT OF ALL CLAIMS. IN NO EVENT SHALL SELLER BE LIABLE FOR ANY OBLIGATION GREATER THAN THE ORIGINAL PURCHASE PRICE OF THE PRODUCT UNDER THIS WARRANTY. PURCHASER SHALL AFFORD SELLER PROMPT AND REASONABLE OPPORTUNITY TO INSPECT THE PRODUCT FOR WHICH A CLAIM IS MADE. THE SOLE PURPOSE OF THE FOREGOING STIPULATED EXCLUSIVE REMEDY SHALL BE TO REPAIR OR REPLACE DEFECTIVE PRODUCTS OR COMPONENTS THEREOF, OR TO REFUND PURCHASER THE PURCHASE PRICE THEREOF. THIS STIPULATED EXCLUSIVE REMEDY SHALL NOT BE DEEMED TO HAVE FAILED OF ITS ESSENTIAL PURPOSE SO LONG AS SELLER IS WILLING AND ABLE TO REPAIR OR REPLACE THE DEFECTIVE PARTS OR REFUND THE PURCHASE PRICE IN ACCORDANCE WITH THE TERMS HEREOF. PRODUCTS THAT HAVE BEEN REPAIRED OR REPLACED UNDER THIS WARRANTY DO NOT RECEIVE A NEW WARRANTY AND ARE ONLY COVERED BY THE REMAINING PORTION OF THE ORIGINAL WARRANTY.

LIMITATION OF REMEDIES

The foregoing stipulated exclusive remedy is in lieu of all other remedies for breach of contract, warranty, and/or tort or otherwise. Seller shall not be liable, either directly or indirectly, for any consequential, incidental or special losses or damages of Purchaser, including but not limited to the Purchaser's expenses for downtime or for making up downtime, damages for which the Purchaser may be liable to other persons and/or entities, damages to property, and injury to or death of any persons and/or any claims for incidental or consequential damages, including but not limited to loss of profits, regardless of whether Seller has been informed of the possibility of such damages. Seller neither assumes, nor authorizes any person to assume for it, any other liability in connection with the sale or use of any Products covered by the foregoing Warranty and Disclaimers, and there are no oral agreements relating to remedies which are collateral to or which affect this limitation.

CONTACT CENTER

- 3425 East Locust Street
Davenport, IA 52803

ph: 800.BLAST.IT (800.252.7848)

ph: 563.324.2519

fax: 563.324.6258

REGIONAL BRANCH OFFICES

- **Iowa**
Davenport
- **Louisiana**
Gonzales
Lafayette
- **Ohio**
Youngstown
- **Texas**
Beaumont
Corpus Christi
Deer Park



ABRASIVES

BLASTING

COATING

DUST COLLECTORS

ENGINEERED SYSTEMS

RENTAL

SAFETY

SERVICE, REPAIR, & MODERNIZATION

VACUUMS

40+ NATIONWIDE SHIPPING LOCATIONS



★ Marco Regional Branch Offices
and Shipping Locations

● Direct Shipping Locations

CONTACT MARCO

800.BLAST.IT
(800.252.7848)

563.324.2519

FAX: 563.324.6258

WWW.MARCO.US
SALES@MARCO.US