



# BINKS® TROPHY AIR SPRAY GUN



## PART NUMBERS AND SCHEMATICS GUIDE

## Company Profile

Since 1944, Marco has developed a strong tradition of providing innovative and reliable products and services to the surface preparation and protective coatings industries. We are the world's premier provider of Abrasives, Blasting Equipment, Coating Equipment, Engineered Systems, Rental Equipment, Safety Equipment, Service, and Repair.

Through innovative designs and a total commitment to quality, Marco manufactures products that increase production rates, create a safer workplace, and reduce maintenance costs. Marco's industry experience, manufacturing capabilities, legendary customer service, product availability, logistics services, and technology leadership is your assurance that we deliver high quality products and services, providing the best value to you, our customer.

## The Marco Difference

- **Industry Experience** – With Marco on your team, you have access to expertise which can only come from decades of industry leadership. We have organized our engineering department, production specialists, customer operations, and safety support into a “Center of Competence.” As a Marco customer, you have access to hundreds of years of cumulative experience related to your operations.
- **Manufacturing Excellence** – Marco is a U.S. based, ISO 9001:2008 certified manufacturer of equipment for the Surface Preparation and Protective Coatings industries. Marco's engineers benchmark the industry to ensure that we design and manufacture superior products that set the “Gold Standard” for performance, safety, and quality.
- **Legendary Customer Service** – Marco's legendary customer service team is staffed by friendly, highly-trained individuals who are focused on providing the highest level of product support, order accuracy, and customer satisfaction.
- **Product Availability** – We stock over 10,000 SKU's and have over 45 shipping locations to serve North American and International markets for all major brands of blasting and painting equipment. As the largest provider of surface preparation and protective coatings equipment in the world, our inventory levels and product availability are unmatched.
- **Logistics Services** – Marco's in-house logistics team is dedicated to moving your shipment anywhere in the world. We move over 14,000 truckloads every year, allowing you to save on freight costs by leveraging our buying power. Lower your process costs with a single invoice, which includes product and freight.
- **Technology Leadership** – Our website provides: Operator's Manuals, Part Numbers and Schematics Guides, MSDS information, and Features and Specifications Guides, providing access to information 24/7. Our Extranet application allows you to receive quotes and place orders online. Our Intranet maintains a complete record of your purchase history to assist with ongoing support of your existing equipment and future purchasing decisions.

## Vision Statement

Marco is the world's premier provider of Abrasives, Blasting Equipment, Coating Equipment, Engineered Systems, Rental Equipment, Safety Equipment, Service, and Repair.

## Mission Statement

Marco provides strong leadership and innovation to the surface preparation and protective coatings industries. We dedicate our efforts to the continuous improvement of our products, services, processes, people, and most importantly, the quality of our customer's experience.

## Quality Statement

Marco is committed to providing superior quality in the design, manufacturing, distribution, rental, service, and repair of our products. Our ISO 9001:2008 certification extends throughout all operations in all locations. Continuous improvement of our processes and supply chain Integration comprise the core of our business strategy for delivering exceptional quality and value in all Marco products and services.

## Management Philosophy

We are a company dedicated to the success of every customer and associate. We discuss, debate, challenge, measure, and test our ideas. We will be boundless and limitless in our passion to improve. Through sound leadership and dedicated associates, we will ensure a long term, profitable future for Marco, our associates, customers, and suppliers.

# TABLE OF CONTENTS

<b>Company Profile</b> .....	<b>2</b>
<b>Table of Contents</b> .....	<b>3</b>
<b>Binks® Trophy Air Spray Guns</b> .....	<b>4-15</b>
Conventional Pressure/Siphon Feed Air Spray Gun . . . .	4
Conventional Gravity Feed Air Spray Gun .....	5
Conventional Round Air Spray Gun .....	5
LVMP Pressure/Siphon Feed Air Spray Gun .....	6
LVMP Gravity Feed Air Spray Gun .....	7
HVLP Pressure/Siphon Feed Air Spray Gun .....	8
HVLP Gravity Feed Air Spray Gun .....	9
Air Caps .....	10
Retaining Ring .....	10
Fluid Tips and Needles .....	11
Binks® Trophy Pressure/Siphon Feed Air Spray Gun Part Numbers and Schematics .....	12-13
Binks® Trophy Gravity Feed Air Spray Gun Part Numbers and Schematics .....	14-15
<b>Optional Accessories</b> .....	<b>16-22</b>
3/8" I.D. Fluid Hose .....	16
3/8" I.D. Fluid Hose Couplings .....	16
5/16" I.D. Air Hose .....	17
5/16" I.D. Air Hose Couplings .....	17
Cups .....	18
1 qt. Siphon Cup .....	19
900cc Aluminum Cup .....	20
4 oz. Gravity Cup .....	21
8 oz. Siphon Cup .....	22
<b>Maintenance Notes</b> .....	<b>23</b>

## PART NUMBERS AND SCHEMATICS GUIDE



### Part Numbers

<b>BINKS® TROPHY CONVENTIONAL AIR SPRAY GUN</b>					
<b>Part Numbers</b>	<b>Type</b>	<b>1 qt Siphon Cup (Included)</b>	<b>Air Cap</b>	<b>Fluid Nozzle Size</b>	<b>Material Handling (Viscosity)</b>
20BK246510CN11S0	Pressure		11-C	1.0 mm (0.039 in)	Thin and Non-Stick Coatings
20BK246512CN11S0	Pressure		11-C	1.2 mm (0.047 in)	Thin, Medium, and Mold Release
20BK246514CN11S0	Pressure		11-C	1.4 mm (0.055 in)	Thin, Medium, Hammers, and Wrinkle Enamels
20BK246516CN11S0	Pressure		11-C	1.6 mm (0.063 in)	Thin, Medium, Heavy, Hammers, and Wrinkle Enamels
20BK246518CN11S0	Pressure		11-C	1.8 mm (0.071 in)	Medium and Heavy
20BK246516CN12S0	Pressure		12-C	1.6 mm (0.063 in)	Thin, Medium, Heavy, and Hammers
20BK246514CN14V0	Pressure		14-C	1.4 mm (0.055 in)	Ceramics
20BK246518CN14V0	Pressure		14-C	1.8 mm (0.071 in)	Ceramics
20BK246520CN14S0	Pressure		14-C	2.0 mm (0.079 in)	Medium, Heavy, and Adhesives
20BK246522CN14S0	Pressure		14-C	2.2 mm (0.087 in)	Medium, Heavy, and Adhesives
20BK246522CN14V0	Pressure		14-C	2.2 mm (0.087 in)	Ceramics and Zinc Rich Coatings
20BK246526CN14V0	Pressure		14-C	2.6 mm (0.102 in)	Ceramics
20BK246516CN12SS	Siphon	X	12-C	1.6 mm (0.063 in)	Thin and Medium
20BK246518CN12SS	Siphon	X	12-C	1.8 mm (0.071 in)	Thin, Medium, Adhesives, and Non-Stick Coatings

## PART NUMBERS AND SCHEMATICS GUIDE



**Part Numbers**

### BINKS® TROPHY CONVENTIONAL GRAVITY FEED AIR SPRAY GUN

	Type	900cc Aluminum Cup (Included)	Air Cap	Fluid Nozzle Size	Material Handling (Viscosity)
20BK246614CN12SG	Gravity	X	12-C	1.4 mm (0.055 in)	Thin
20BK246616CN12SG	Gravity	X	12-C	1.6 mm (0.063 in)	Thin
20BK246616CN12SG	Gravity	X	12-C	1.6 mm (0.063 in)	Medium
20BK246618CN12SG	Gravity	X	12-C	1.8 mm (0.071 in)	Medium



**Part Numbers**

### BINKS® TROPHY CONVENTIONAL ROUND AIR SPRAY GUN

	Type	1 qt Siphon Cup (Included)	Air Cap	Fluid Nozzle Size	Material Handling (Viscosity)
20BK246512CN16S0	Pressure		16	1.2 mm (0.047 in)	Thin and Medium

## PART NUMBERS AND SCHEMATICS GUIDE



**Part Numbers**

<b>BINKS® TROPHY LVMP AIR SPRAY GUN</b>					
<b>Part Numbers</b>	<b>Type</b>	<b>1 qt Siphon Cup (Included)</b>	<b>Air Cap</b>	<b>Fluid Nozzle Size</b>	<b>Material Handling (Viscosity)</b>
<b>20BK246585LV22S0</b>	Pressure		22-L	0.85 mm (0.035 in)	Thin
<b>20BK246510LV22S0</b>	Pressure		22-L	1.0 mm (0.039 in)	Thin
<b>20BK246512LV23S0</b>	Pressure		23-L	1.2 mm (0.047 in)	Thin and Medium
<b>20BK246514LV23S0</b>	Pressure		23-L	1.4 mm (0.055 in)	Thin and Medium
<b>20BK246514LV24S0</b>	Pressure		23-L	1.4 mm (0.055 in)	Medium
<b>20BK246585LV25S0</b>	Pressure		25-L	0.85 mm (0.035 in)	Thin
<b>20BK246510LV25S0</b>	Pressure		25-L	1.0 mm (0.039 in)	Thin
<b>20BK246518LV25S0</b>	Pressure		25-L	1.8 mm (0.071 in)	Medium
<b>20BK246518LV23SS</b>	Siphon	X	23-L	1.8 mm (0.071 in)	Thin and Medium
<b>20BK246514LV25SS</b>	Siphon	X	25-L	1.4 mm (0.055 in)	Medium

## PART NUMBERS AND SCHEMATICS GUIDE



### Part Numbers

<b>BINKS® TROPHY LVMP GRAVITY FEED AIR SPRAY GUN</b>					
<b>Part Numbers</b>	<b>Type</b>	<b>900cc Aluminum Cup (Included)</b>	<b>Air Cap</b>	<b>Fluid Nozzle Size</b>	<b>Material Handling (Viscosity)</b>
<b>20BK246612LV23SG</b>	Gravity	X	23-L	1.2 mm (0.047 in)	Thin
<b>20BK246614LV23SG</b>	Gravity	X	23-L	1.4 mm (0.055 in)	Thin
<b>20BK246614LV23SG</b>	Gravity	X	23-L	1.4 mm (0.055 in)	Medium
<b>20BK246618LV23SG</b>	Gravity	X	23-L	1.8 mm (0.071 in)	Medium

## PART NUMBERS AND SCHEMATICS GUIDE



### Part Numbers

<b>BINKS® TROPHY HVLP AIR SPRAY GUN</b>					
<b>Part Numbers</b>	<b>Type</b>	<b>1 qt Siphon Cup (Included)</b>	<b>Air Cap</b>	<b>Fluid Nozzle Size</b>	<b>Material Handling (Viscosity)</b>
20BK246585HV31P0	Pressure		31-H	0.85 mm (0.035 in)	Thin
20BK246510HV31P0	Pressure		31-H	1.0 mm (0.039 in)	Thin
20BK246512HV31P0	Pressure		31-H	1.2 mm (0.047 in)	Thin and Medium
20BK246514HV31P0	Pressure		31-H	1.4 mm (0.055 in)	Medium and Heavy
20BK246585HV32S0	Pressure		32-H	0.85 mm (0.035 in)	Thin
20BK246510HV32S0	Pressure		32-H	1.0 mm (0.039 in)	Thin
20BK246512HV32S0	Pressure		32-H	1.2 mm (0.047 in)	Thin and Medium
20BK246514HV32S0	Pressure		32-H	1.4 mm (0.055 in)	Medium and Heavy
20BK246516HV32S0	Pressure		32-H	1.6 mm (0.063 in)	Medium and Heavy
20BK246518HV32S0	Pressure		32-H	1.8 mm (0.071 in)	Medium and Heavy
20BK246585HV33S0	Pressure		33-H	0.85 mm (0.035 in)	Thin
20BK246510HV33S0	Pressure		33-H	1.0 mm (0.039 in)	Thin
20BK246585HV39S0	Pressure		39-H	0.85 mm (0.035 in)	Thin
20BK246510HV39S0	Pressure		39-H	1.0 mm (0.039 in)	Thin
20BK246512HV39S0	Pressure		39-H	1.2 mm (0.047 in)	Thin and Medium
20BK246514HV39S0	Pressure		39-H	1.4 mm (0.055 in)	Medium
20BK246518HV32SS	Siphon	X	32-H	1.2 mm (0.047 in)	Thin and Medium
20BK246514HV32SS	Siphon	X	32-H	1.4 mm (0.055 in)	Medium



## PART NUMBERS AND SCHEMATICS GUIDE



### Part Numbers

<b>BINKS® TROPHY HVLP GRAVITY FEED AIR SPRAY GUN</b>					
<b>Part Numbers</b>	<b>Type</b>	<b>900cc Aluminum Cup (Included)</b>	<b>Air Cap</b>	<b>Fluid Nozzle Size</b>	<b>Material Handling (Viscosity)</b>
<b>20BK246612HV32SG</b>	Gravity	X	32-H	1.2 mm (0.047 in)	Thin
<b>20BK246614HV32SG</b>	Gravity	X	32-H	1.4 mm (0.055 in)	Thin
<b>20BK246614HV32SG</b>	Gravity	X	32-H	1.4 mm (0.055 in)	Medium
<b>20BK246618HV32SG</b>	Gravity	X	32-H	1.8 mm (0.071 in)	Medium

## PART NUMBERS AND SCHEMATICS GUIDE



### Part Numbers

AIR CAPS				
	Trophy Gun Type	Cap Number	Spray Pattern Range	Type
<b>20BK266500</b>	Conventional	11-C	8-12"	Pressure
<b>20BK466501</b>	Conventional	12-C	4-12"	Pressure and Siphon
<b>20BK466503</b>	Conventional	14-C	8-14"	Pressure
<b>20BK466505</b>	Round	16	2-4"	Pressure and Siphon
<b>20BK466510</b>	LVMP	22-L	4-12"	Pressure and Siphon
<b>20BK466511</b>	LVMP	23-L	4-12"	Pressure
<b>20BK466512</b>	LVMP	24-L	2-6"	Pressure and Siphon
<b>20BK466513</b>	LVMP	25-L	4-15"	Pressure
<b>20BK466517</b>	HVLP	31-H	8-12"	Pressure and Siphon
<b>20BK466518</b>	HVLP	32-H	8-14"	Pressure and Siphon
<b>20BK466519</b>	HVLP	33-H	8-12"	Pressure
<b>20BK466525</b>	HVLP	39-H	4-12"	Pressure

### Part Numbers

RETAINING RING	
	Description
<b>20BK546120</b>	Binks® Trophy Air Cap Retaining Ring



## PART NUMBERS AND SCHEMATICS GUIDE



**Part  
Numbers**

### FLUID TIPS AND NEEDLES

**Orifice Size**

**Fluid Needle**

Part Numbers	Orifice Size	Fluid Needle
20BK451105050	0.50 mm (0.020 in)	20BK476825
20BK451105085	0.85 mm (0.035 in)	20BK476825
20BK451105010	1.0 mm (0.039 in)	20BK476825
20BK451105012	1.2 mm (0.047 in)	20BK476825
20BK451105014	1.4 mm (0.055 in)	20BK476825
20BK451108014	1.4 mm (0.055 in)	20BK476830
20BK451105016	1.6 mm (0.063 in)	20BK476825
20BK451105018	1.8 mm (0.071 in)	20BK476825
20BK451108018	1.8 mm (0.071 in)	20BK476830
20BK451106020	2.0 mm (0.079 in)	20BK476825
20BK451106022	2.2 mm (0.087 in)	20BK476825
20BK451108022	2.2 mm (0.087 in)	20BK476830
20BK451106026	2.6 mm (0.102 in)	20BK476825
20BK451108026	2.6 mm (0.102 in)	20BK476830

## PART NUMBERS AND SCHEMATICS GUIDE

### Binks® Trophy Pressure/Siphon Feed Air Spray Gun

Item#	Part#	Description	Item#	Part#	Description
<b>Fig. 1</b>			30	20BK546132K	Trigger Screw Nut Kit <i>(Includes Item #'s: 31 and 32)</i>
1	20BK546120	Air Cap Retaining Ring Assembly <i>(See Page 10)</i>	31	—	Trigger Screw
5	—	Air Cap <i>(See Page 10)</i>	32	—	Trigger Nut
6	20BKJGA156K10	Spring-Clip <i>(Quantity of Ten)</i>	33	20BK543513	Valve Spindle Cap
7	—	Fluid Nozzle <i>(See Page 11)</i>	34	20BKSN11	Plug
8	20BK546102K3	Baffle & Separator Kit <i>(Quantity of Three)</i>	35	20BK6112	Fitting – Air Inlet
9	20BK546122	Side Port Valve Assembly <i>(Includes Item #'s: 10, 11, 12, 13, and 14)</i>	36	—	Gun Body with Fluid Inlet
10	—	Retaining Clip	37	—	Tool – Seal Insertion
11	—	Body Bushing	38	—	Gunner's Mate
12	—	O-Ring	—	20BK81800	1 qt Suction Cup <i>(For Siphon Feed Models)</i>
13	—	Side Port Stem	—	20BKGTI428K5	Side Port Repair Kit <i>(Includes Item #'s: 10, 12, and 14)</i>
14	—	Pin	—	20BK546135	Binks® Trophy Repair Kit <i>(Includes Item #'s: 15, 18, 23, and 28)</i>
15	20BK546131K	Air Valve Service Kit <i>(Includes Item #'s: 16, 17, 19, and 20)</i>	—	201V538	Brochure – Binks® Trophy Air Spray Gun
16	—	Front Seal – Air Valve	—	206M600	Part Numbers and Schematics Guide – Binks® Trophy Air Spray Gun
17	—	Front Air Valve Seal	—	209V535	Operator's Manual – Binks® Trophy Pressure/Siphon Feed Air Spray Gun
18	20BK546109	Air Valve Spindle			
19	—	Air Valve Spring			
20	—	Rear Seal – Air Valve			
21	20BKSN66	Housing			
22	20BK476825	Needle – Stainless Steel (Standard)			
—	20BK476830	Needle – Tungsten Carbide			
—	20BK476826	Needle – Plastic Tip			
23	20BK546133K3	Spring/Pad Assembly – Standard <i>(Quantity of Three)</i>			
—	20BK546134K	Spring/Pad Assembly Kit – Heavy Duty <i>(Optional)</i>			
24	20BK546111	Knob – Needle Adjusting			
25	20BK246130K	Needle Packing Kit – Standard <i>(Includes Item #'s: 26, 27, and 28)</i>			
—	20BK546129K	Needle Packing Kit – Vitreous <i>(Includes Item #'s: 26, 27, and 28)</i>			
26	—	Nut – Packing			
27	—	Spring for Packing			
28	—	Needle Packing – Standard			
—	20BKSN2K3	Needle Packing – Standard <i>(Quantity of Three)</i>			
—	—	Needle Packing – Vitreous <i>(Quantity of Three)</i>			
29	20BK544360	Trigger			

# PART NUMBERS AND SCHEMATICS GUIDE

Figure 1: Binks® Trophy Pressure/Siphon Feed Air Spray Gun

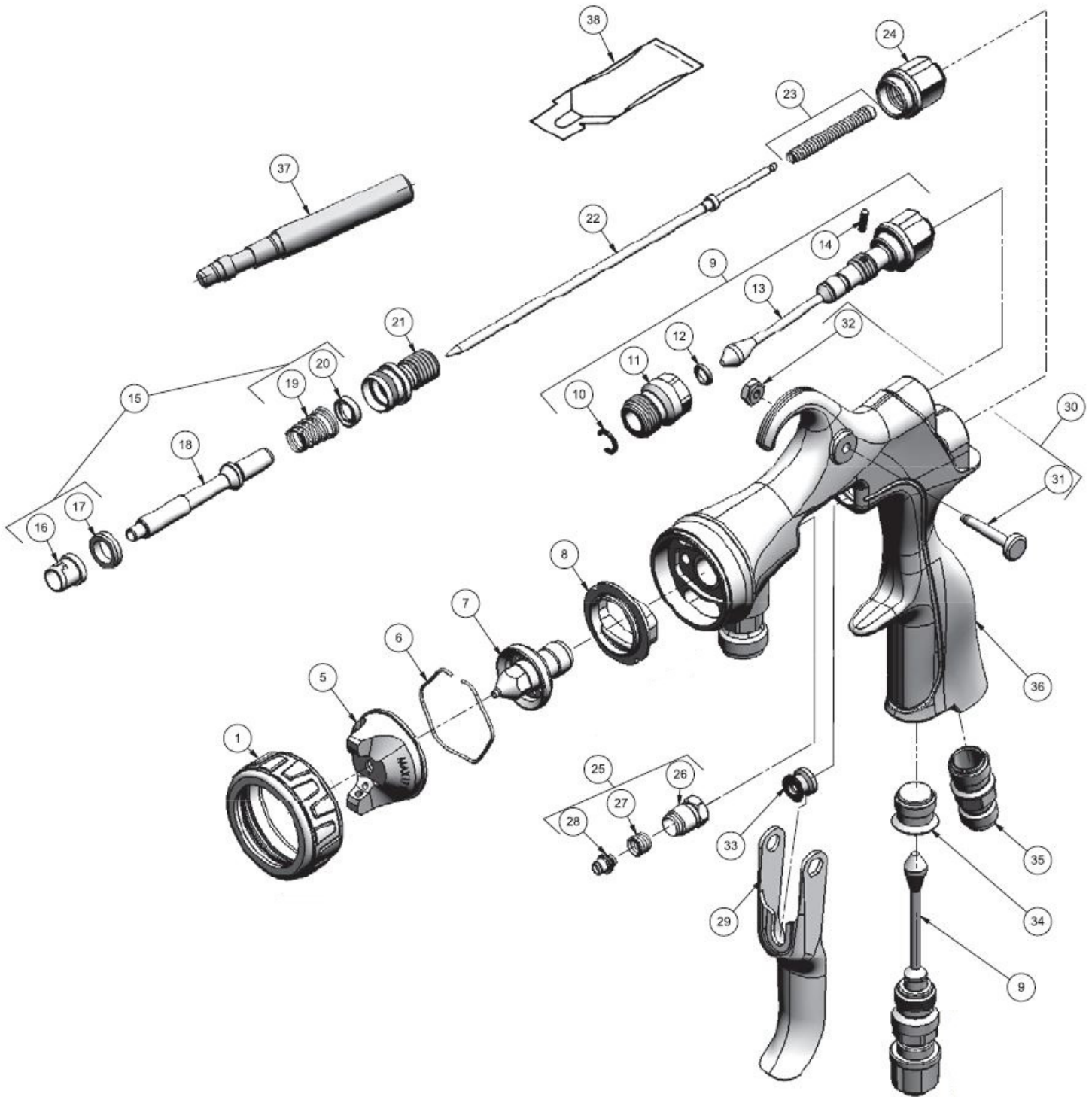

## PART NUMBERS AND SCHEMATICS GUIDE

### Binks® Trophy Gravity Feed Air Spray Gun

Item#	Part#	Description	Item#	Part#	Description
<b>Fig. 2</b>			—	20BKGT1428K5	Side Port Repair Kit <i>(Includes Item #'s: 10, 12, and 14)</i>
1	20BK546120	Air Cap Retaining Ring Assembly <i>(See Page 10)</i>	—	20BK546135	Binks® Trophy Repair Kit <i>(Includes Item #'s: 15, 18, 23, and 28)</i>
5	—	Air Cap <i>(See Page 10)</i>	—	201V538	Brochure – Binks® Trophy Air Spray Gun
6	20BKJGA156K10	Spring-Clip <i>(Quantity of Ten)</i>	—	206M600	Part Numbers and Schematics Guide – Binks® Trophy Air Spray Gun
7	—	Fluid Nozzle <i>(See Page 11)</i>	—	209V536	Operator's Manual – Binks® Trophy Gravity Feed Air Spray Gun
8	20BK546102K3	Baffle & Separator Kit <i>(Quantity of Three)</i>			
9	20BK546122	Side Port Valve Assembly <i>(Includes Item #'s: 10, 11, 12, 13, and 14)</i>			
10	—	Retaining Clip			
11	—	Body Bushing			
12	—	O-Ring			
13	—	Side Port Stem			
14	—	Pin			
15	20BK546131K	Air Valve Service Kit <i>(Includes Item #'s: 16, 17, 19, and 20)</i>			
16	—	Front Seal – Air Valve			
17	—	Front Air Valve Seal			
18	20BK546109	Air Valve Spindle			
19	—	Air Valve Spring			
20	—	Rear Seal – Air Valve			
21	20BKSN66	Housing			
22	20BK476825	Needle – Stainless Steel <i>(Standard)</i>			
23	20BK546133K3	Spring/Pad Assembly – Standard <i>(Quantity of Three)</i>			
24	20BK546111	Knob – Needle Adjusting			
25	20BK246130K	Needle Packing Kit – Standard <i>(Includes Item #'s: 26, 27, and 28)</i>			
26	—	Nut – Packing			
27	—	Spring for Packing			
28	—	Needle Packing – Standard			
—	20BKSN2K3	Needle Packing – Standard <i>(Quantity of Three)</i>			
29	20BK544360	Trigger			
30	20BK546132K	Trigger Screw Nut Kit <i>(Includes Item #'s: 31 and 32)</i>			
31	—	Trigger Screw			
32	—	Trigger Nut			
33	20BK543513	Valve Spindle Cap			
34	20BKSN11	Plug			
35	20BK6112	Fitting – Air Inlet			
36	—	Gun Body with Fluid Inlet			
37	—	Tool – Seal Insertion			
38	—	Gunner's Mate			
—	20BK546106	900cc Aluminum Cup			

# PART NUMBERS AND SCHEMATICS GUIDE

Figure 2: Binks® Trophy Gravity Feed Air Spray Gun

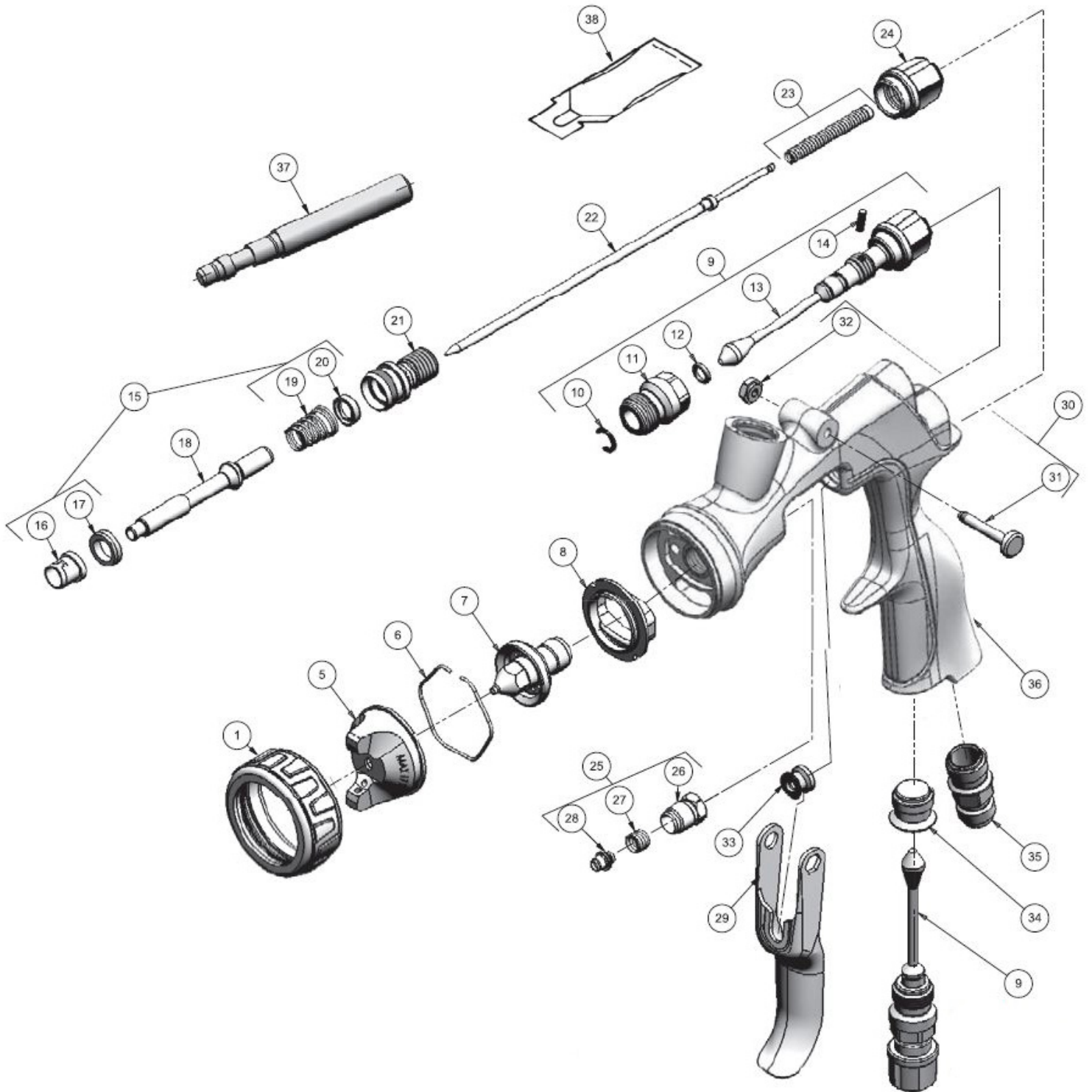





## PART NUMBERS AND SCHEMATICS GUIDE

		<b>3/8" I.D. FLUID HOSE</b>				
	<b>Part Numbers</b>	<b>Length</b>	<b>Hose I.D.</b>	<b>Hose O.D.</b>	<b>Working Pressure</b>	<b>Hose Cover Color</b>
	<b>20FH038</b>	Per Ft.	3/8"	11/16"	750 psi	Black

		<b>3/8" I.D. FLUID HOSE WITH COUPLINGS INSTALLED</b>					
	<b>Part Numbers</b>	<b>Length</b>	<b>Hose I.D.</b>	<b>Hose O.D.</b>	<b>Working Pressure</b>	<b>Hose Cover Color</b>	<b>Couplings</b>
	<b>20FH03825AC</b>	25 Ft.	3/8"	11/16"	750 psi	Black	2080020
	<b>20FH03850AC</b>	50 Ft.	3/8"	11/16"	750 psi	Black	2080020



		<b>COUPLINGS AND HEX NIPPLE FOR 3/8" I.D. FLUID HOSE</b>	
	<b>Part Numbers</b>	<b>Thread Style</b>	<b>Working Pressure</b>
	<b>2080020</b>	3/8" Compression Fitting x 3/8" Female NPS	250 psi
	<b>1028610</b>	3/8" Male x 3/8" Male Hex Nipple	1,000 psi







## PART NUMBERS AND SCHEMATICS GUIDE

		5/16" I.D. AIR HOSE				
	<b>Part Numbers</b>	Length	Hose I.D.	Hose O.D.	Working Pressure	Hose Cover Color
	<b>20AH0516</b>	Per Ft.	5/16"	5/8"	200 psi	Red

		5/16" I.D. AIR HOSE WITH COUPLINGS INSTALLED					
	<b>Part Numbers</b>	Length	Hose I.D.	Hose O.D.	Working Pressure	Hose Cover Color	Couplings
	<b>20AH051625AC</b>	25 Ft.	5/16"	5/8"	200 psi	Red	2080010
	<b>20AH051650AC</b>	50 Ft.	5/16"	5/8"	200 psi	Red	2080010

		COUPLING AND HEX NIPPLE FOR 5/16" I.D. AIR HOSE	
	<b>Part Numbers</b>	Thread Style	Working Pressure
	<b>2080010</b>	5/16" Female x 1/4" Female NPT Air Hose Coupling	250 psi
	<b>20PFHA24SA0404</b>	1/4" Male x 1/4" Male Air Hose Hex Nipple	6,000 psi

# OPTIONAL ACCESSORIES

		<b>CUPS</b>	
<b>Part Numbers</b>		<b>Description</b>	
	<b>20BK81800</b>	1 qt. Siphon Cup	
	<b>20BK546106</b>	900cc Aluminum Cup	
	<b>20BK544458</b>	4 oz. Gravity Cup	
	<b>20BK81384</b>	8 oz. Siphon Cup	

## OPTIONAL ACCESSORIES

**Figure 3: Binks® 1 qt. Siphon Cup**

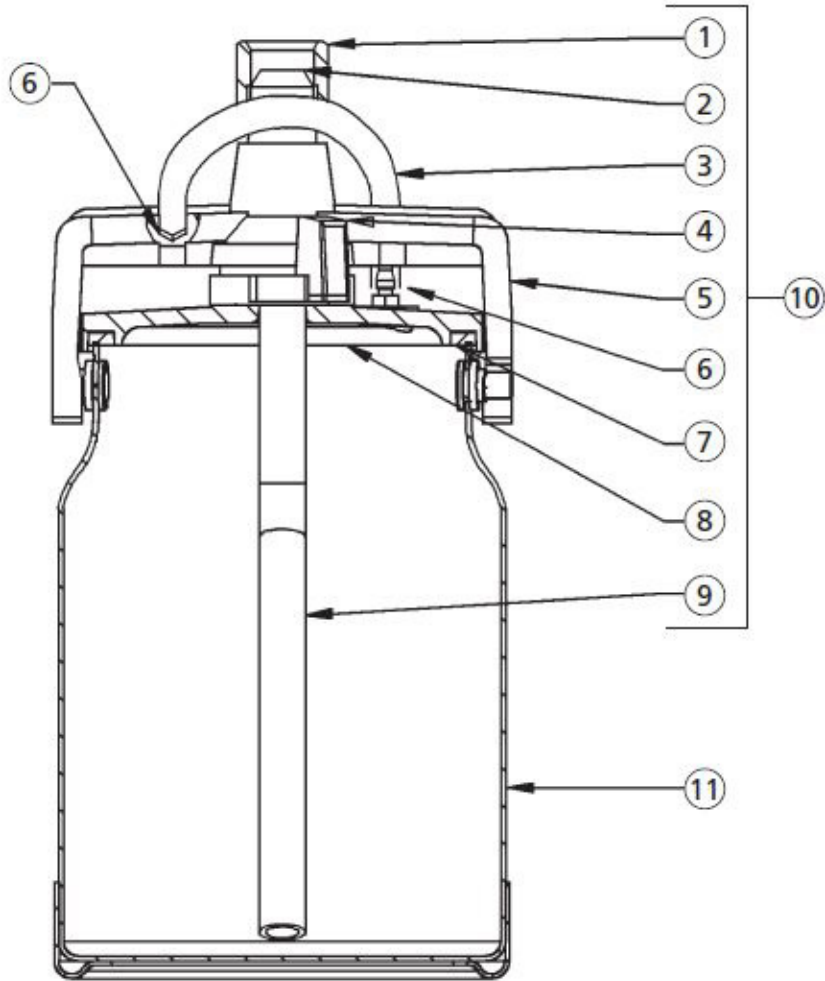

Item#	Part#	Description
<b>Fig. 3</b>		
—	<b>20BK81800</b>	<b>Binks® 1 qt. Siphon Cup</b>
1	—	Swivel Nut
2	—	Adapter
3	20BK81803	Drip Proof Tube ( <i>Quantity of Two</i> )
4	—	Lever
5	—	Yoke
6	20BK81307	Connector ( <i>Quantity of Two</i> )
7	20BKTGC9	Gasket
8	—	Cover Machining
9	—	Fluid Tube
10	20BK81801	Cover Assembly ( <i>Includes Item #'s: 1, 2, 3, 4, 5, 6, 7, 8, and 9</i> )
11	20BK824282	1 qt. Cup Assembly
—	20BK81806	Cup Cover Repair Kit ( <i>Includes Item #'s: 1, 2, 3, 4, 6, and 7</i> )
—	209V562	Operator's Manual – Binks® 1 qt. Siphon Cup

## OPTIONAL ACCESSORIES

**Figure 4: Binks® 900cc Aluminum Cup**

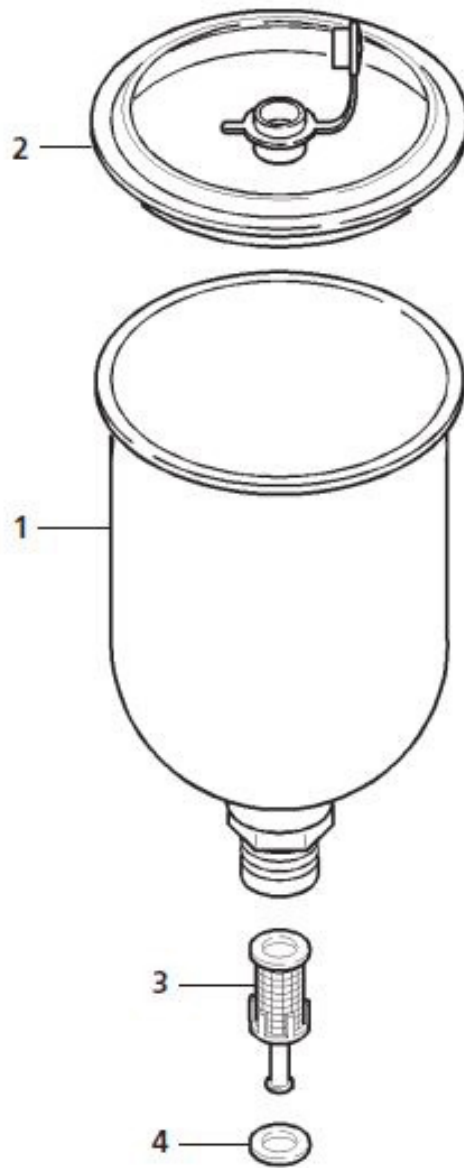

Item#	Part#	Description
<b>Fig. 4</b>		
—	<b>20BK546106</b>	<b>Binks® 900cc Aluminum Cup</b>
1	—	Metal Gravity Feed Cup (900cc)
2	20BKGFC404K2	Disposable Lid Kit ( <i>Quantity of Two</i> )
3	20BKKGP5K5	Filter Kit ( <i>Quantity of Five</i> )
4	20BKKGP13K5	Cup Gasket ( <i>Quantity of Five</i> )
—	209V563	Operator's Manual – Binks® 900cc Aluminum Cup

## OPTIONAL ACCESSORIES

Figure 5: Binks® 4 oz. Gravity Cup

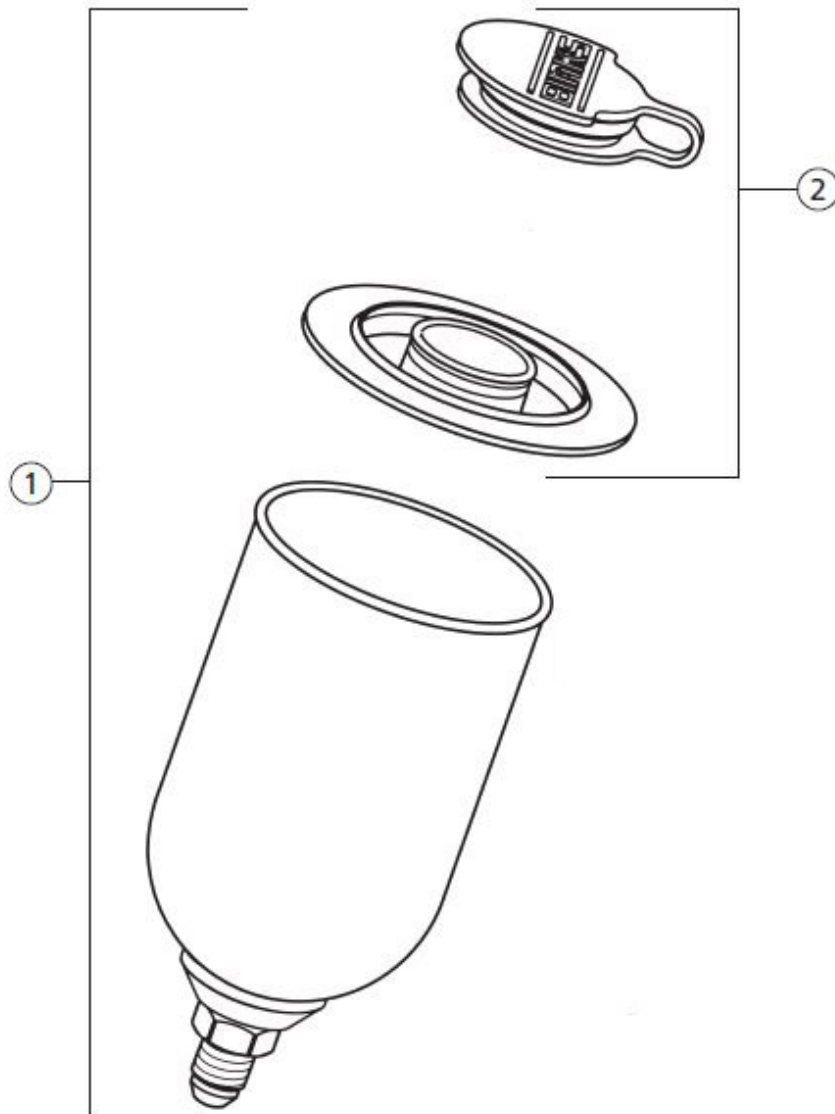

Item#	Part#	Description
Fig. 5		
1	20BK544458	Binks® 4 oz. Gravity Cup
2	20BK544459	4 oz. Cup Lid Assembly
—	209V564	Operator's Manual – Binks® 900cc Aluminum Cup

## OPTIONAL ACCESSORIES

**Figure 6: Binks® 8 oz. Siphon Cup**

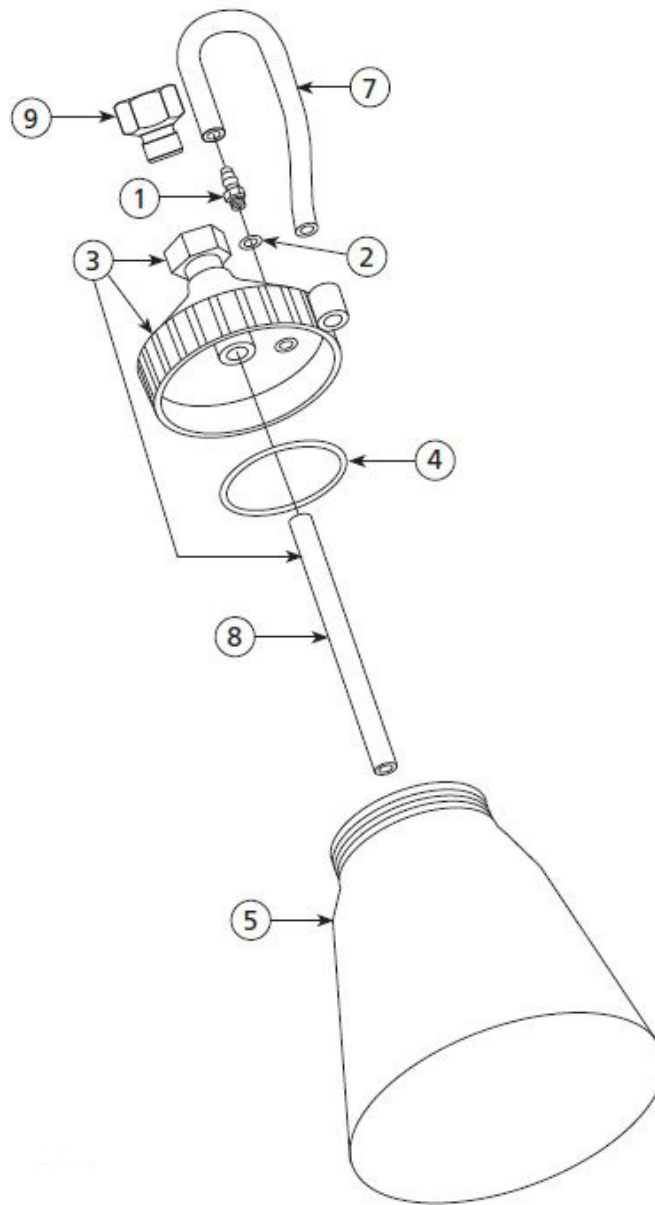

Item#	Part#	Description
<b>Fig. 6</b>		
—	<b>20BK81384</b>	<b>Binks® 8 oz. Siphon Cup</b>
1	20BK81307	10-32 Connector
2	20BK543925	Gasket
3	20BK81386	Cup Cover Assembly
4	20BK206685	Lid Gasket O-Ring
5	20BK544475	8 oz. Cup
—	20BK544476	Storage Cover
7	20BK544328	3-3/4" Vent Tube
8	—	Pick-Up Tube
9	20BKAD404	1/4" (M) x 3/8" (F) Adapter
—	209V565	Operator's Manual – Binks® 8 oz. Siphon Cup



## GLOBAL HEADQUARTERS

- 3425 East Locust Street  
Davenport, IA 52803

ph: 800.BLAST.IT (800.252.7848)

ph: 563.324.2519

fax: 563.324.6258

## GULF STATES HEADQUARTERS

- 701 East Boulevard  
Deer Park, TX 77536

ph: 800.BLAST.IT (800.252.7848)

ph: 281.930.0905

fax: 281.542.0736

## REGIONAL BRANCH OFFICES

- **Iowa**  
Davenport
- **Louisiana**  
Gonzales  
Lafayette
- **Ohio**  
Youngstown
- **Texas**  
Beaumont  
Corpus Christi  
Deer Park



ABRASIVES

BLASTING

COATING

DUST COLLECTORS

ENGINEERED SYSTEMS

RENTAL

SAFETY

SERVICE & REPAIR

VACUUMS

## 40+ NATIONWIDE SHIPPING LOCATIONS



★ Marco Regional Branch Offices  
and Shipping Locations

● Direct Shipping Locations

## CONTACT MARCO

**800.BLAST.IT**

**(800.252.7848)**

**563.324.2519**

**FAX: 563.324.6258**

**WWW.MARCO.US**

**SALES@MARCO.US**