

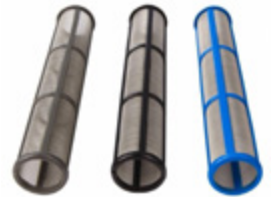

AIRLESS SPRAYER ACCESSORIES



PART NUMBERS AND SCHEMATICS GUIDE

Company Profile

Since 1944, Marco has developed a strong tradition of providing innovative and reliable products and services to the surface preparation and protective coatings industries. We are the world's premier provider of Abrasives, Blasting, Coating, Dust Collectors, Engineered Systems, Rental, Safety, Service, Repair, & Modernization, and Vacuums.

Through innovative designs and a total commitment to quality, Marco manufactures products that increase production rates, create a safer workplace, and reduce maintenance costs. Marco's industry experience, manufacturing capabilities, legendary customer service, product availability, logistics services, and technology leadership is your assurance that we deliver high quality products and services, providing the best value to you, our customer.

The Marco Difference

- **Industry Experience** – With Marco on your team, you have access to expertise which can only come from decades of industry leadership. We have organized our engineering department, production specialists, customer operations, and safety support into a “Center of Competence.” As a Marco customer, you have access to hundreds of years of cumulative experience related to your operations.
- **Manufacturing Excellence** – Marco is a U.S. based, ISO 9001:2008 certified manufacturer of equipment for the Surface Preparation and Protective Coatings industries. Marco's engineers benchmark the industry to ensure that we design and manufacture superior products that set the “Gold Standard” for performance, safety, and quality.
- **Legendary Customer Service** – Marco's legendary customer service team is staffed by friendly, highly-trained individuals who are focused on providing the highest level of product support, order accuracy, and customer satisfaction.
- **Product Availability** – We stock over 10,000 SKU's and have more than 45 shipping locations to serve North American and International markets for all major brands of blasting and coating equipment. As the largest provider of surface preparation and protective coatings equipment in the world, our inventory levels and product availability are unmatched.
- **Logistics Services** – Marco's in-house logistics team is dedicated to moving your shipment anywhere in the world. We move more than 14,000 truckloads every year, allowing you to save on freight costs by leveraging our buying power. Lower your process costs with a single invoice, which includes product and freight.
- **Technology Leadership** – Our website provides: Operator's Manuals, Part Numbers and Schematics Guides, SDS information, and Features & Specifications Guides, providing access to information 24/7. Our Extranet application allows you to receive quotes and place orders online. Our Intranet maintains a complete record of your purchase history to assist with ongoing support of your existing equipment and future purchasing decisions.

Vision Statement

Marco is the world's premier provider of Abrasives, Blasting, Coating, Dust Collectors, Engineered Systems, Rental, Safety, Service, Repair, & Modernization, and Vacuums.

Mission Statement

Marco provides strong leadership and innovation to the surface preparation and protective coatings industries. We dedicate our efforts to the continuous improvement of our products, services, processes, people, and most importantly, the quality of our customer's experience.

Quality Statement

Marco is committed to providing superior quality in the design, manufacturing, distribution, rental, service, and repair of our products. Our ISO 9001:2008 certification extends throughout all operations in all locations. Continuous improvement of our processes and supply chain Integration comprise the core of our business strategy for delivering exceptional quality and value in all Marco products and services.







Management Philosophy

We are a company dedicated to the success of every customer and associate. We discuss, debate, challenge, measure, and test our ideas. We will be boundless and limitless in our passion to improve. Through sound leadership and dedicated associates, we will ensure a long term, profitable future for Marco, our associates, customers, and suppliers.

TABLE OF CONTENTS



Company Profile	2
Table of Contents	3
Airless Sprayer Accessories	4-14
Jiffy Mixers	4
Drill	4
Plastic Bucket and Lids	5
Metal Buckets	5
Bucket Grids	5
Mesh Strainers	6
Suction Hose and Tubes	7
Suction Hose with Couplings	7
Siphon Kits	7
Inlet Strainers	8
Inlet Strainers – Wire Cage & Bag	8
Replacement Filter Bags	8
Filters Supports	9
Replacement Screen Filter Elements	9
Manifold Outlet Filters	9
High Pressure Ball Valves	10
Fluid Drain Valves	10
Air Pressure Regulators	11
Air Pressure Gauges	11
Fluid Pressure Gauges	11
Throat Seal Liquid	12
Pump Armor Fluid	12
15 Gallon Hopper – For Use With Graco® Airless Spray Pumps	13
15 Gallon Hopper – For Use With Cart Mounted Binks® Airless Spray Pumps	14
Maintenance Notes	15

PART NUMBERS AND SCHEMATICS GUIDE

		JIFFY MIXERS						
Part Numbers	Container Size	Shaft Length	Shaft Diameter	Top Diameter	Bottom Diameter	Material of Construction	U.O.M.	
	20JMHS2	1–2 Gallon	14-3/4"	1/4"	2-5/8"	2-5/8"	Stainless Steel	One Each
	20JHS3	1–2 Gallon	30"	1/4"	2-5/8"	2-5/8"	Stainless Steel	One Each
	20JMES210	2–5 Gallon	20-1/2"	3/8"	3-1/4"	3-3/4"	Stainless Steel	One Each
	20JMPS1	5–10 Gallon	20-1/2"	1/2"	3-1/4"	3-3/4"	Stainless Steel	One Each
	20JPS227	10–50 Gallon	27-1/2"	1/2"	4-5/8"	5-1/8"	Stainless Steel	One Each
	20JPS2	10–50 Gallon	40"	1/2"	4-5/8"	5-1/8"	Stainless Steel	One Each

		DRILL
Part Numbers	Description	
	10HF936510VGA	1/2" Pneumatic Reversible Drill





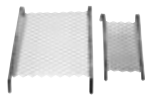

PART NUMBERS AND SCHEMATICS GUIDE

		PLASTIC BUCKETS AND LIDS					
		Size	Bucket	Handle	Lid	Color	U.O.M.
	2070090	1 Gallon	X	X		White	One Each
	2070092	2 Gallon	X	X		White	One Each
	2070094	5 Gallon	X	X		White	One Each
	2070091	1 Gallon			X	White	One Each
	2070093	2 Gallon			X	White	One Each
	2070095	5 Gallon			X	White	One Each





		METAL BUCKETS			
		Size	Lid	Handle	U.O.M.
	2070057	1 Gallon	X	X	One Each
	2070058	5 Gallon	X	X	One Each





		BUCKET GRIDS			
		Bucket Size	Grid Width	Material	U.O.M.
	2070165	1 Gallon	4"	Metal	One Each
	2070155	2 Gallon	6"	Metal	One Each
	2070138	5 Gallon	9"	Metal	One Each

PART NUMBERS AND SCHEMATICS GUIDE

	Part Numbers	MESH STRAINERS		
		Size	Elastic Top	U.O.M.
	20BD14516B	1 Gallon		One Each
	2070182	1 Gallon	X	25/Package
	20BK20200	2 Gallon		20/Package
	20BD14517B	5 Gallon		12/Package
	20BD1513969	5 Gallon	X	12/Package
	2070096	5 Gallon	X	25/Box
	2070005	55 Gal Drum		One Each

PART NUMBERS AND SCHEMATICS GUIDE

		SUCTION HOSE AND TUBES	
Part Numbers	Description		
	20G197682	1" Suction Tube	
	20G245136	55 Gallon Suction Tube Extension Kit <i>(Includes Suction Tube and Couplings)</i>	
	20BE13499	3/4" I.D. x 3' Suction Hose	
	20BE132557	1" I.D. x 4' Suction Hose	
	20BE132558	1" I.D. x 5' Suction Hose	

		SUCTION HOSE WITH COUPLINGS	
Part Numbers	Description	Couplings	
	20BE13491	3/4" I.D. x 3-1/2' Suction Hose	3/4" NPT (M) x 3/4" NPT (M)
	20BE13492	3/4" I.D. x 6' Suction Hose	3/4" NPT (M) x 3/4" NPT (M)
	20BE132556	1" I.D. x 6' Suction Hose	1" NPT (M) Rigid x 1" NPT (M) Swivel
	20G247301	1" I.D. x 6' Suction Hose	1" MNPT x Quick Connect Fitting
	20G247302	1" I.D. x 10' Suction Hose	1" MNPT x Quick Connect Fitting

		SIPHON KITS				
Part Numbers	For Use With	Material	Suction Hose I.D.	Suction Hose Length	Swivel Fitting	
	20G207484	5 gal Pail	Aluminum	3/4"	3.5'	3/4" NPT (F)
	20G208920	5 gal Pail	Aluminum	1"	4'	3/4" NPT (F)
	20G208259	55 gal Drums	Carbon Steel	3/4"	6'	3/4" NPT (F)

PART NUMBERS AND SCHEMATICS GUIDE

	Part Numbers	INLET STRAINERS				
		Size	Double Screen	Stainless Steel Cap	Nylon Cap	U.O.M.
	20G181073	1/2"	X	X		One Each
	20G237675	1/2"	X		X	One Each
	20G183770	3/4"	X	X		One Each
	20G235004	3/4"	X		X	One Each
	20G246385	7/8"	X		X	One Each
	20G181072	1"	X	X		One Each
	20G189920	1"		X		One Each
	20G237840	1-1/4"		X		One Each

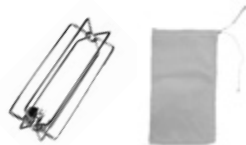
	Part Numbers	INLET STRAINERS – WIRE CAGE & BAG				
		Size	Stainless Steel Cap	Nylon Cap	Alternative	U.O.M.
	20G210726	1-1/4" O.D.	X	X		One Each
	20G210726B	1-1/4" O.D.	X	X	X	One Each

	Part Numbers	REPLACEMENT STRAINER BAGS				
		Size	Stainless Steel Cap	Nylon Cap	Alternative	U.O.M.
	20G238769	1"	X	X		25/PKG
	20G238769B	1"	X	X	X	25/PKG



PART NUMBERS AND SCHEMATICS GUIDE



		FILTER SUPPORTS		
		Type	Material	Maximum Working Pressure
	20G186075	Filter Support	Nylon	7,250 psi
	20G171939B	Filter Support	Aluminum	7,250 psi

		REPLACEMENT SCREEN FILTER ELEMENTS	
		Screen	Package
	20G167024B	30 Mesh	1 Pack
	20G167025B	60 Mesh	1 Pack
	20G224459	60 Mesh	2 Pack
	20G167026B	100 Mesh	1 Pack
	20G167027	200 Mesh	1 Pack
	20G224469	200 Mesh	2 Pack

		MANIFOLD OUTLET FILTERS				
		Airless Sprayer (For Use With)	Length & Color	Mesh Size	Alternative	U.O.M.
	20G244071	Ultra Max, GMax, GH 200, and Hydra Max	7.1" – Gray	30 Mesh		One Each
	20G244071B	Ultra Max, GMax, GH 200, and Hydra Max	7.1" – Gray	30 Mesh	X	One Each
	20G243080	ST PRO	3.5" – Black	60 Mesh		One Each
	20G246384	ST, STX, Ultra 395/495/595	3.5" – Black	60 Mesh		One Each
	20G244067	Ultra Max, GMax, GH 200, and Hydra Max	7.1" – Black	60 Mesh		One Each
	20G244067B	Ultra Max, GMax, GH 200, and Hydra Max	7.1" – Black	60 Mesh	X	One Each
	20G246382	ST, STX, Ultra 395/495/595	3.5" – Blue	100 Mesh		One Each
	20G244068	Ultra Max, GMax, GH 200, and Hydra Max	7.1" – Blue	100 Mesh		One Each
	20G244068B	Ultra Max, GMax, GH 200, and Hydra Max	7.1" – Blue	100 Mesh	X	One Each



PART NUMBERS AND SCHEMATICS GUIDE

	Part Numbers	HIGH PRESSURE BALL VALVES		
		Thread Size	Seal Material	Working Pressure
	20G210657B	1/4" Male x 1/4" Male	Viton	5,000 psi
	20G210658B	3/8" Male x 3/8" Male	Viton	5,000 psi
	20G210659B	1/4" Male x 3/8" Male	Viton	5,000 psi
	20G214037	1/4" Male x 1/4" Male	Teflon	5,000 psi
	20G223959B	3/8" Male x 1/4" Male	Teflon	5,000 psi
	20G210658B	3/8" Male x 3/8" Male	Teflon	5,000 psi
	20DQVAE2AO14	1/4" Female x 1/4" Female	Nitrile	7,000 psi
	20DQVAE2AO38	3/8" Female x 3/8" Female	Nitrile	7,000 psi
	20DQVAE2AO12	1/2" Female x 1/2" Female	Nitrile	7,000 psi

	Part Numbers	FLUID DRAIN VALVES		
		Inlet	Outlet	Maximum Working Pressure
	20G210657	1/4" NPT	1/4" NPT	5,000 psi
	20G210659	1/4" NPT	3/8" NPT	5,000 psi
	20G210658	3/8" NPT	3/8" NPT	5,000 psi



PART NUMBERS AND SCHEMATICS GUIDE



AIR PRESSURE REGULATORS				
	Part Numbers	Size	Maximum SCFM	Maximum Initial Pressure
	20BE26712	1/4"	60	300 psi
	20BE36713	3/8"	90	300 psi
	20BE36714	1/2"	200	300 psi
	20BE36716	3/4"	380	300 psi
	20BE36718	1"	380	300 psi

AIR PRESSURE GAUGES				
	Part Numbers	Size	Maximum Working Pressure	Face
	20G108190	1/8" Back	100 psi	1-1/2" Glass
	20G113911	1/8" Back	160 psi	1-1/2" Glass
	1028606	1/4" Back	160 psi	2" Glass
	20G101689	1/4" Back	200 psi	2" Glass
	20G104655	1/8" Bottom	60 psi	1-1/2" Glass
	20G110436	1/8" Bottom	100 psi	1-1/2" Glass
	10BS19683	1/4" Bottom	30 psi	2" Glass
	20BK832727	1/4" Bottom	100 psi	2" Glass
	20BK831355	1/4" Bottom	100 psi	2-1/2" Glass
	10C00024B	1/4" Bottom	160 psi	2" Glass
	20G100960	1/4" Bottom	200 psi	2" Plastic
	20G102814	1/4" Bottom	5000 psi	2-1/2" Glass – Liquid Filled

FLUID PRESSURE GAUGES				
	Part Numbers	Size	Maximum Working Pressure	Face
	20G102814B	1/4" Bottom	5,000 psi	2-1/2" Glass – Liquid Filled
	20G114434	1/4" Back	10,000 psi	2-1/2" Glass – Liquid Filled

PART NUMBERS AND SCHEMATICS GUIDE

		THROAT SEAL LIQUID
Part Numbers		Description
	20G206994	Throat Seal Liquid – 8 oz.
	20G206995	Throat Seal Liquid – 1 qt.
	20G206996	Throat Seal Liquid – 1 gal.

		PUMP ARMOR FLUID
Part Numbers		Description
	20G243103	Pump Armor Fluid – 1 qt.
	20G245133	Pump Armor Fluid – 1 gal.

PART NUMBERS AND SCHEMATICS GUIDE

Figure 1: 15 Gallon Hopper – For Use With Graco® Airless Spray Pumps

Item #	Part #	Description
Fig. 1		
—	20100668	15 Gallon Hopper – for use with Graco® Airless Spray Pumps**
1	20100614	Stainless Steel Lid – 15 Gallon Hopper
2	20100610	Stainless Steel Hopper
3	20100667	1-1/2" x 7-1/2" Galvanized Pipe Nipple
4	1011603	1-1/2" Full Port Ball Valve
5	1014015	1-1/2" Galvanized Close Nipple (<i>Two Required</i>)
6	10102398	1-1/2" NPT Galvanized Pipe Union
7	1011842	1-1/2" 90° Galvanized Elbow
8	20100664	Hopper Mounting Bracket
9	1035046	5/16-18 Nut (<i>Two Required</i>)
10	20100670	Bolt (<i>Two Required</i>)
11	10L805014	5/16" Lock Washer (<i>Two Required</i>)
12	20G288603	Hopper Mounting Bracket Assembly (<i>Includes Items: A and 8–11</i>)
—	2090009	Technical Data Sheet – 15 Gallon Paint Hopper – for use with Graco® Airless Spray Pumps

*Item A is not available for individual sale

**Does not attach to Graco® XL Pumps

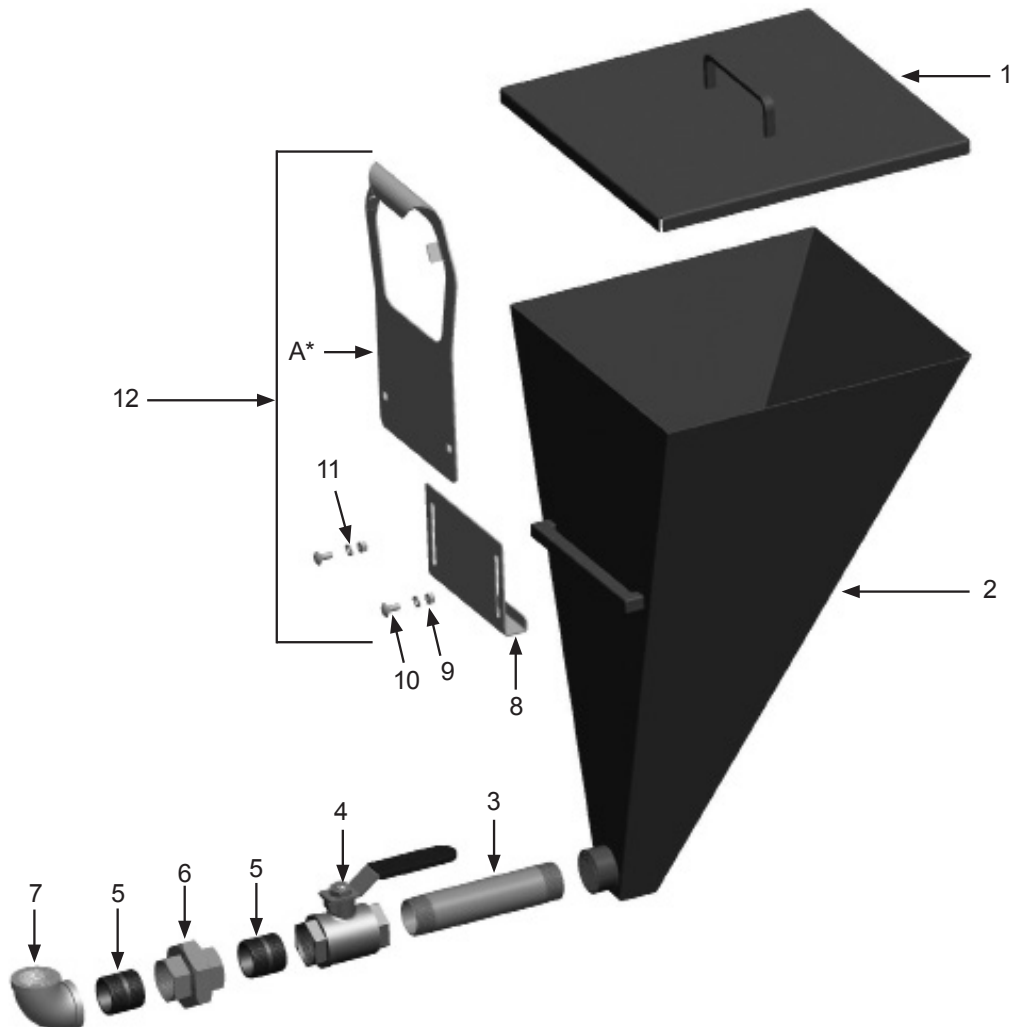

PART NUMBERS AND SCHEMATICS GUIDE

Figure 2: 15 Gallon Hopper – For Use With Cart Mounted Binks® Airless Spray Pumps

Item #	Part #	Description
Fig. 2		
—	20100669	15 Gallon Paint Hopper – for use with Binks® Cart Mounted Airless Spray Pumps
1	20100614	Stainless Steel Lid – 15 Gallon Hopper
2	20100610	Stainless Steel Hopper
3	1014015	1-1/2" Galvanized Close Nipple (<i>Three Required</i>)
4	1011603	1-1/2" Full Port Ball Valve
5	10102398	1-1/2" NPT Galvanized Pipe Union
6	1011842	1-1/2" 90° Galvanized Elbow
7	20100664	Hopper Mounting Bracket
8	1035046	5/16-18 Nut (<i>Two Required</i>)
9	20100670	Bolt (<i>Two Required</i>)
10	10L805014	5/16" Lock Washer (<i>Two Required</i>)
11	20100665	Binks® Airless Spray Pump Mounting Bracket
12	20G288603	Hopper Mounting Bracket Assembly (<i>Includes Item #'s: 7–11</i>)
—	2090010	Technical Data Sheet – 15 Gallon Paint Hopper – for use with Binks® Cart Mounted Airless Spray Pumps

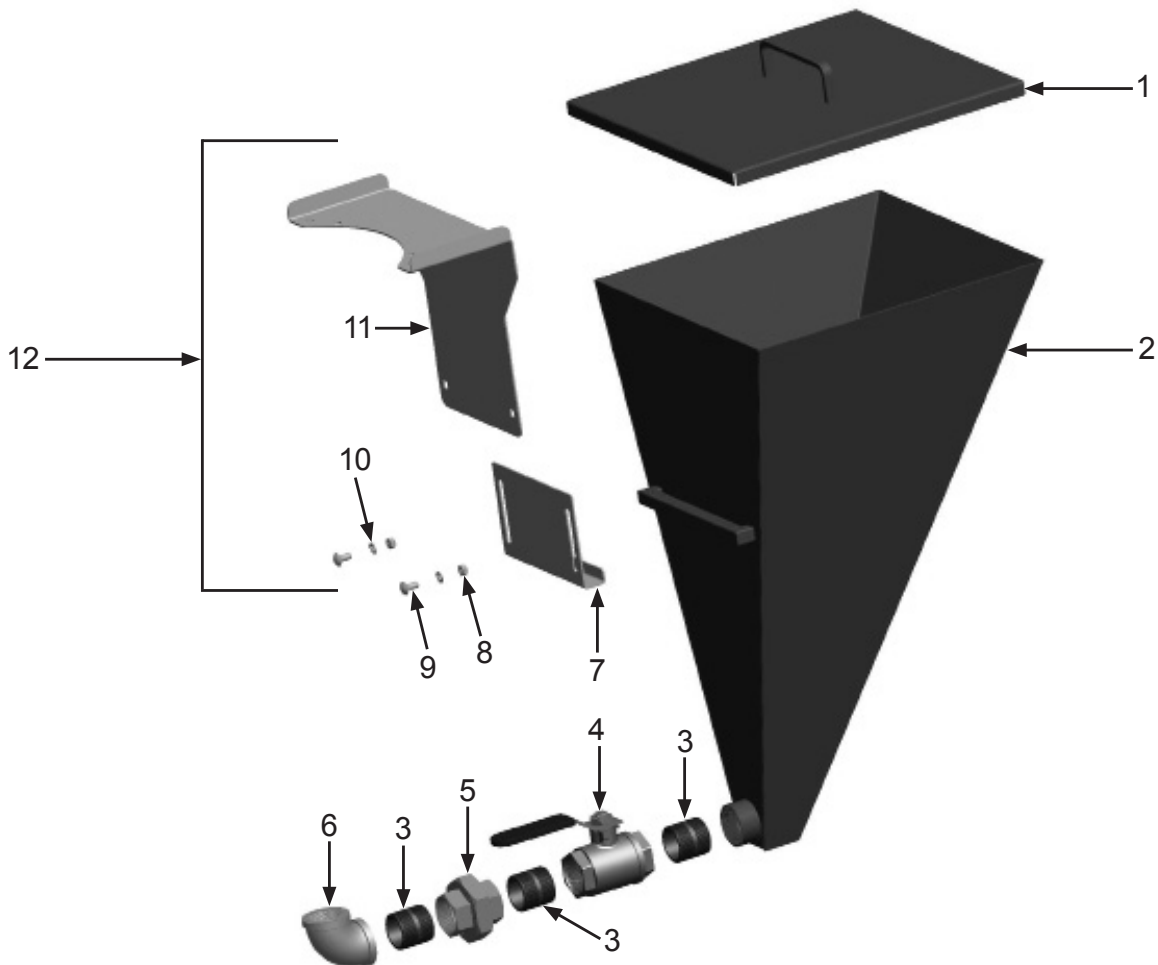

GLOBAL HEADQUARTERS

- 3425 East Locust Street
Davenport, IA 52803

ph: 800.BLAST.IT (800.252.7848)
ph: 563.324.2519
fax: 563.324.6258

REGIONAL BRANCH OFFICES

- **Iowa**
Davenport
- **Louisiana**
Gonzales
Lafayette
- **Ohio**
Youngstown
- **Texas**
Beaumont
Corpus Christi
Deer Park

40+ NATIONWIDE SHIPPING LOCATIONS



★ Marco Regional Branch Offices and Shipping Locations ● Direct Shipping Locations



ABRASIVES
BLASTING
COATING
DUST COLLECTORS
ENGINEERED SYSTEMS
RENTAL
SAFETY
SERVICE, REPAIR, & MODERNIZATION
VACUUMS

CONTACT MARCO

800.BLAST.IT
(800.252.7848)
563.324.2519
FAX: 563.324.6258

WWW.MARCO.US
SALES@MARCO.US