



# MAXXCLEAN® INDUCTION SYSTEM



## PART NUMBERS AND SCHEMATICS GUIDE

## Company Profile

Allredi was formed in the early 2020, when two of the largest distributors in the blasting, coating, safety, and environmental industry, APE Companies and Marco Group International, joined forces. While the qualities both companies are known for have not changed, a lot about our business is new. New abilities. New agilities. New ways to help you win. This calls for a new name, Allredi.

This name exemplifies what we have become. It is completely oriented to the needs of our customers. To your needs. It says that when you call us for anything – products, service, expert advice, anything – you can consider it done. Or even better, Allredi done.

We are your right-now supplier. From skills to SKUs, we deliver the goods fast. So you can be more agile every minute, every day. This is who we are. This is what our new name means. Go ahead and expect excellence, because we're bringing it.

## Our Mission and Vision

To be the industry's preferred partner in surface preparation solutions through unrivaled technical expertise, customer experience, product availability, and tailored service offerings.

## The Allredi Difference

- **Industry Experience** – With Allredi on your team, you have access to expertise which can only come from decades of industry leadership. We have organized our engineering department, production specialists, customer operations, and safety support into a "Center of Competence." As an Allredi customer, you have access to hundreds of years of cumulative experience related to your operations.
- **Manufacturing Excellence** – Allredi is a U.S. based manufacturer of equipment for the Surface Preparation and Protective Coatings industries. Allredi's engineers benchmark the industry to ensure that we design and manufacture superior products that set the "Gold Standard" for performance, safety, and quality.
- **Legendary Customer Service** – Allredi's legendary customer service team is staffed by friendly, highly-trained individuals who are focused on providing the highest level of product support, order accuracy, and customer satisfaction.
- **Product Availability** – We stock over 10,000 SKU's and have over 45 shipping locations to serve North American and International markets for all major brands of blasting, coating, environmental, and safety equipment. Allredi is your right-now supplier, so you can keep your projects moving. From our foundation of strong relationships, we have built a nationwide network that puts vast inventory and ready service close to our customers. We provide advanced expertise, and we deliver the goods fast – so you can easily access the products and services you need to me more agile every minute, every day.
- **Technology Leadership** – Our website provides: Operator's Manuals, Part Numbers and Schematics Guides, SDS information, and key product features and specifications, providing access to information 24/7.

# TABLE OF CONTENTS

<b>Company Profile</b> .....	<b>1</b>
<b>Table of Contents</b> .....	<b>2</b>
<b>MaxxClean Induction System</b> .....	<b>3-8</b>
Part Numbers .....	3
Part Numbers & Schematics .....	4-7
Lid, Screen, & Frame .....	4
Carburator & Bleed-Off Assembly .....	5
Induction Nozzle Assembly .....	6
Wheel Assembly .....	7
Accessories .....	8
<b>Maintenance Notes</b> .....	<b>9-10</b>

# PART NUMBERS

<b>ALLREDI® MAXXCLEAN INDUCTION SYSTEM</b>				
<b>Part Numbers</b>	<b>Trigger Gun</b>	<b>Feed Hose</b>	<b>Lid &amp; Screen</b>	<b>Insulated Lance</b>
10110105	10HQ1001	3/8" ID x 50'	X	36"
10110243	—	3/8" ID x 50'	X	—



## PART NUMBERS & SCHEMATICS

**Figure 1: Lid, Screen, & Frame**

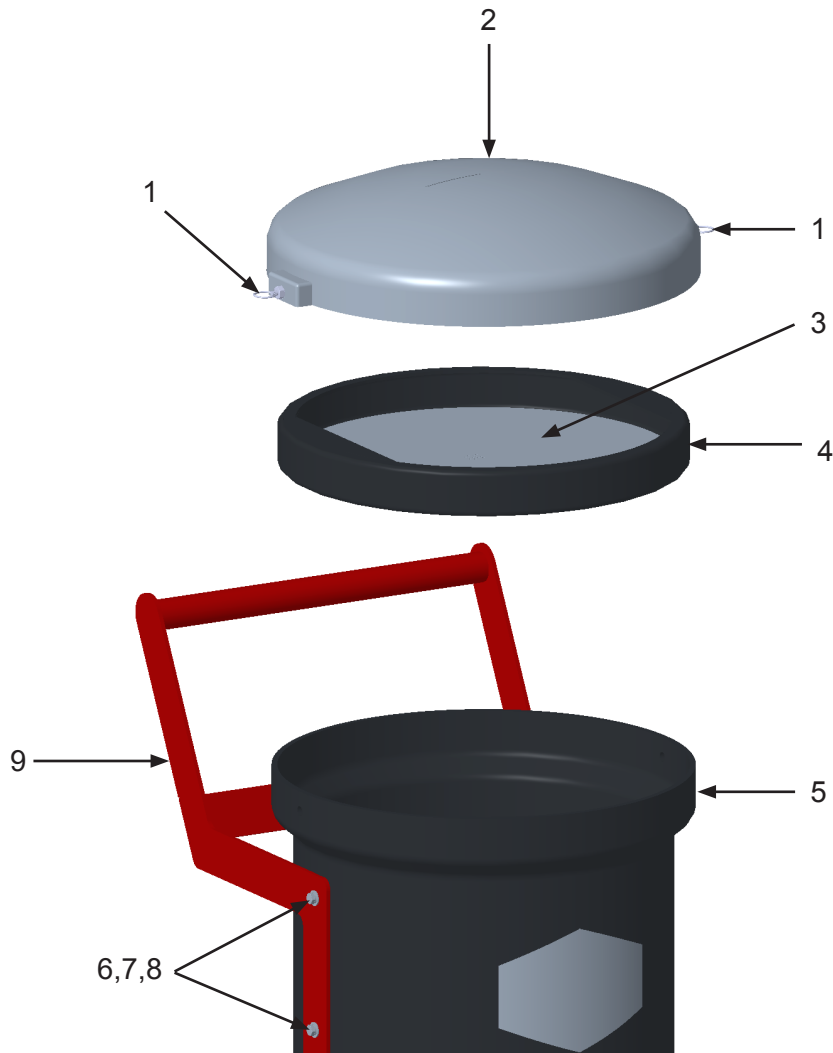

Item #	Part #	Description
<b>Fig. 1</b>		
1	10PPCR002	Lock Ring ( <i>Two Required</i> )
2	10RON024	MaxxClean Lid
3	10110102	Screen
4	10RON002	Screen Holder
5	10RON017	MaxxClean Hopper
6	20100125	1/4-20 x 3/4" Bolt ( <i>Two Required</i> )
7	1012153	1/4" Lock Washer ( <i>Two Required</i> )
8	1014017	1/4" Flat Washer ( <i>Two Required</i> )
9	10110061	Hopper Frame

## PART NUMBERS & SCHEMATICS

**Figure 2: Carburator & Bleed Off Assembly**

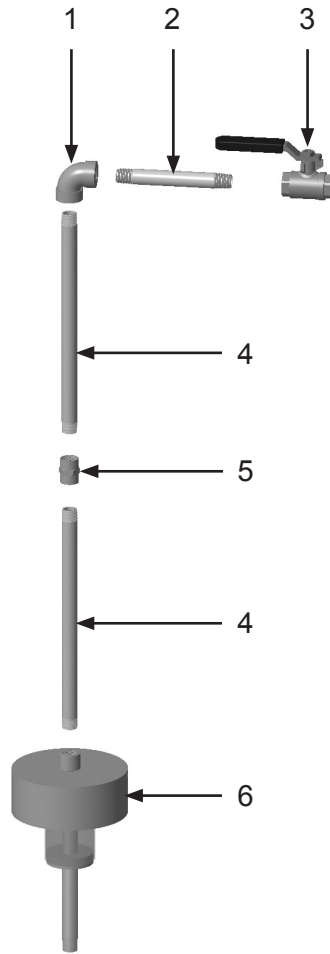

Item #	Part #	Description
<b>Fig. 2</b>		
1	1011823	1/4" Elbow
2	10110104	1/4" x 4" Nipple
3	1080050	1/4" Ball Valve
4	10110103	1/4" x 8" Nipple ( <i>Two Required</i> )
5	20PFHA24SJ04	1/4" F Coupling
6	10110107	Carburator Weldment

## PART NUMBERS & SCHEMATICS

Figure 3: Induction Nozzle Assembly

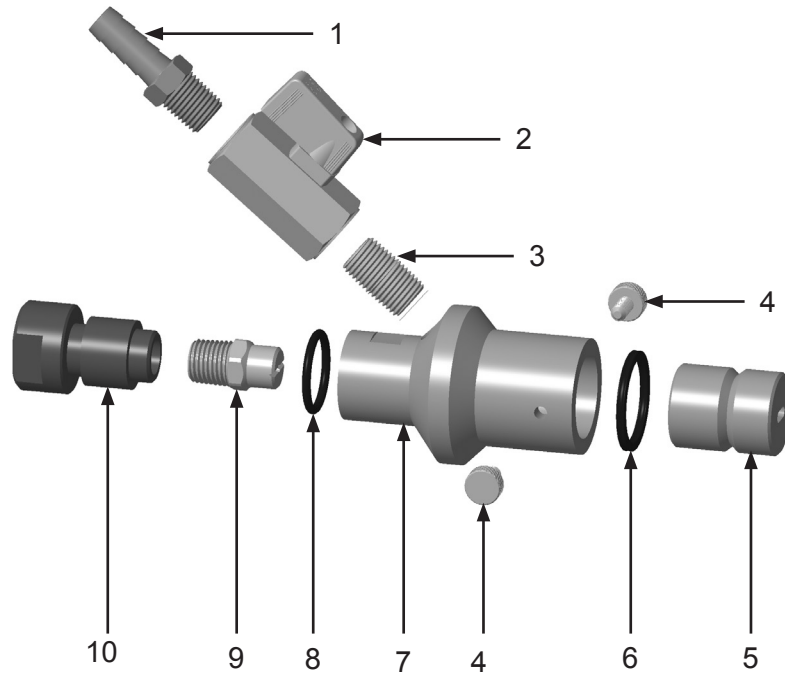

Item #	Part #	Description
<b>Fig. 3</b>		
1	10DXBN32	1/4" NPT Hose Barb
2	10GRIPZA8	1/4" Mini Ball Valve
3	1011210	1/4" x 1-1/2" Nipple
4	10CFC103212	Thumb Screw ( <i>Two Required</i> )
5	10110131	Focal Nozzle, Wide Opening, Stainless Steel
6	10GWL120	O-Ring ( <i>X-Shaped</i> )
7	10COR018D	Induction Housing
8	10GWL117	Round O-Ring
9	10GDWCD052	1/4" MNPT Spray Tip
10	10COR019D	Adapter

## PART NUMBERS & SCHEMATICS

Figure 4: Wheel Assembly

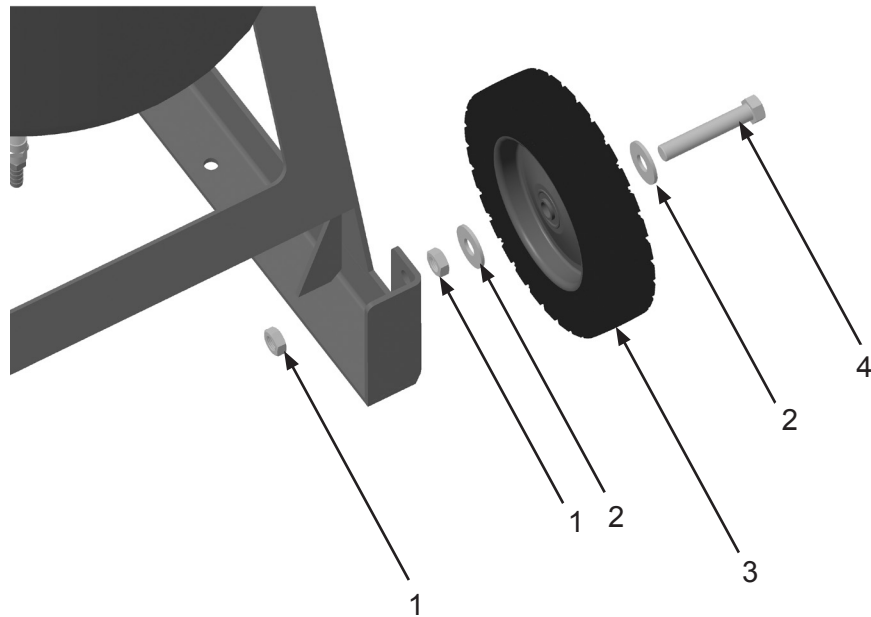



Item #	Part #	Description
<b>Fig. 4</b>		
1	10L804305	1/2" Nut ( <i>Two Required per Wheel</i> )
2	10L804304	1/2" Washer ( <i>Two Required per Wheel</i> )
3	1006065	8" Wheel ( <i>Two Required</i> )
4	10L805329	1/2" x 3" Bolt ( <i>Two Required</i> )



# REPLACEMENT PARTS

## Part Numbers

## REPLACEMENT PARTS

	Part Numbers	REPLACEMENT PARTS
	10HQ1004	36" Insulated Lance
	10HQ1001	Trigger Gun
	10KK0500610X100	3/8" ID Vinyl Hose ( <i>sold per foot</i> )





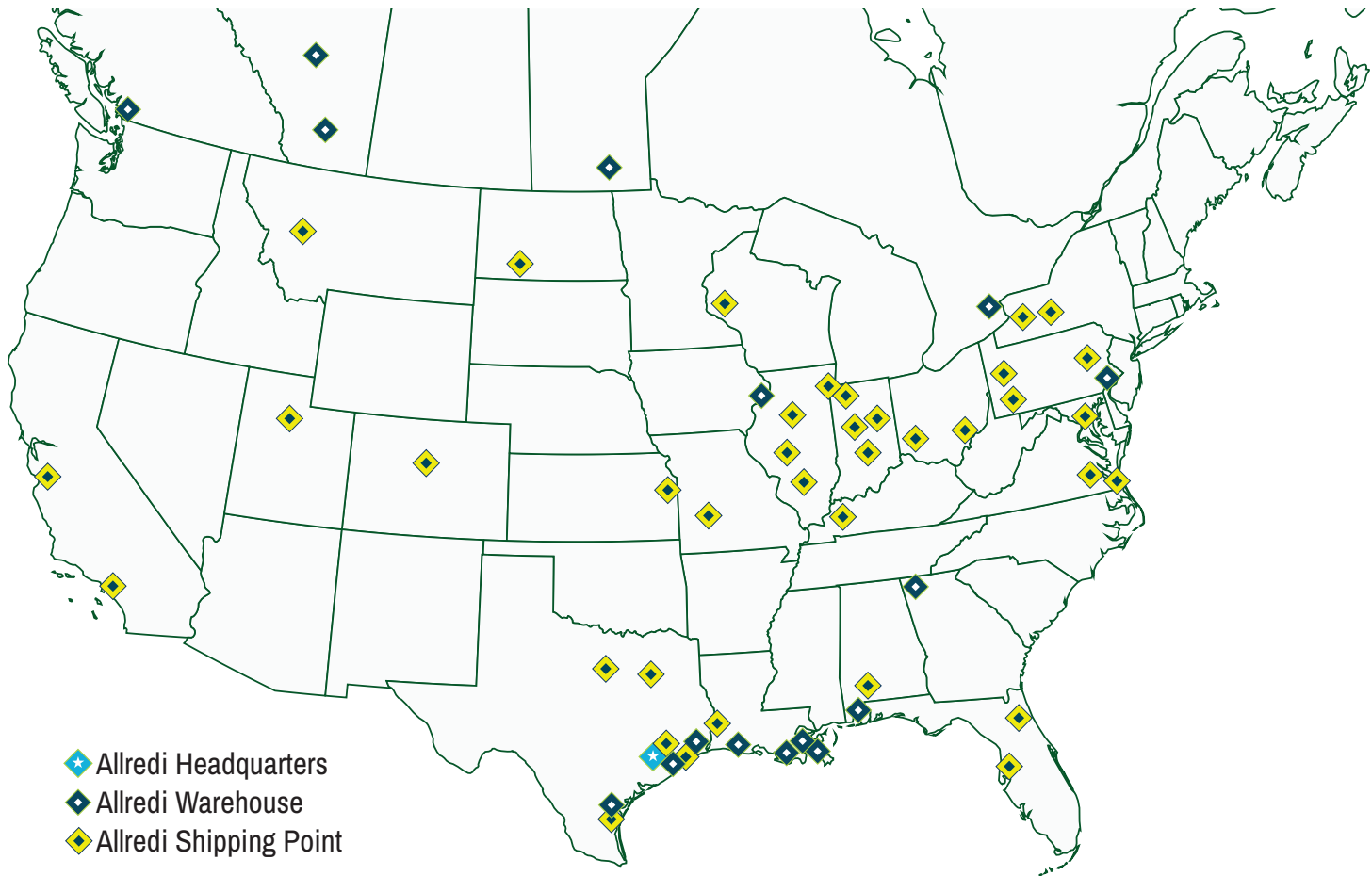

## ALLREDI THERE

Serving these industries: Bridge, Pipeline, Tank & Tower, Concrete Services, Rail, Shipyard & Marine, Pools & Fountains, and Foundry

### UNITED STATES

**Pasadena, TX** (*Headquarters*)  
844.361.7038

**Beaumont, TX**  
409.722.1284

**Bristol, PA**  
215.826.8080

**Corpus Christi, TX**  
361.887.2038

**Davenport, IA**  
563.324.2519

**Deer Park, TX**  
(*Service & Rental Location*)  
281.930.0905

**Duluth, GA**  
800.535.4564

**Gonzales, LA**  
225.647.7575

**Harvey, LA**  
504.367.8090

**Houma, LA**  
985.580.4273

**Lafayette, LA**  
337.267.1440

**Theodore, AL**  
251.338.7525

### CANADA

**Calgary, Alberta**  
403.279.1924

**Coquitlam, BC**  
604.464.6979

**Edmonton, Alberta**  
780.468.2588 (Manus)  
780.425.5510 (Mod-U-Blast)

**Hamilton, Ontario**  
905.527.6000 / 888.794.5665

**Mississauga, Ontario**  
905.890.5837

**Winnipeg, Manitoba**  
204.256.3324

**WWW.ALLREDI-US.COM / 800.252.7848**

**WWW.ALLREDI-CA.COM / 800.661.3842**

Allredi™ and Marco® are registered trademarks of Allredi, LLC.  
Mod-U-Blast® is a registered trademark of Allredi Blast & Abrasives Canada, Inc.  
All other brand names or marks are used for identification purposes and are trademarks of their respective owners.

**ALLREDI™**  
Literature #106MMAXX\_9/10/2024