

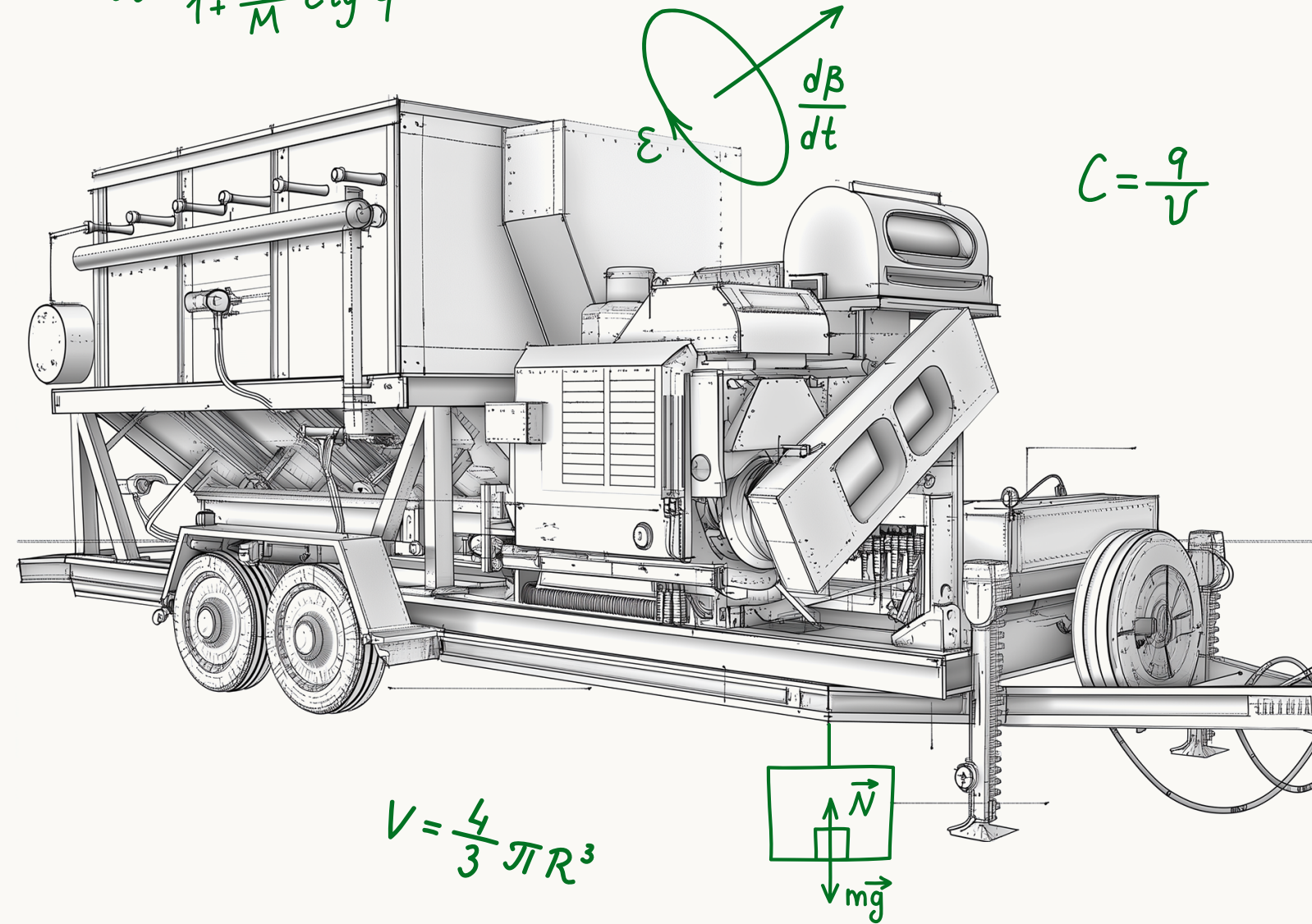

THE EQUIPMENT
EFFICIENCY FORMULA:
**RENT, BUY,
OR BLEND?**

$$a = \frac{g \operatorname{ctg} \varphi}{1 + \frac{m}{M} \operatorname{ctg}^2 \varphi}$$





If you're a blasting pro, you've likely faced or will face a big question that could shake up your whole operation: should you rent or buy your equipment? It's not just about crunching numbers—this decision can make or break your efficiency, tech edge, and competitive game.

Each route has its perks and quirks, and what works for your competitor's business might not be the best bet for you. In this guide, we'll break down the real pros and cons of each approach, helping you make the choice that fits your operation like a glove.

By the time you're done reading, you'll have a better grip on what makes sense for your business, your wallet, and your future in the industry. Whether you're looking to update your equipment strategy or explore new ways to make your mark, we've got you covered.

WHY RENTING MIGHT BE YOUR BEST MOVE

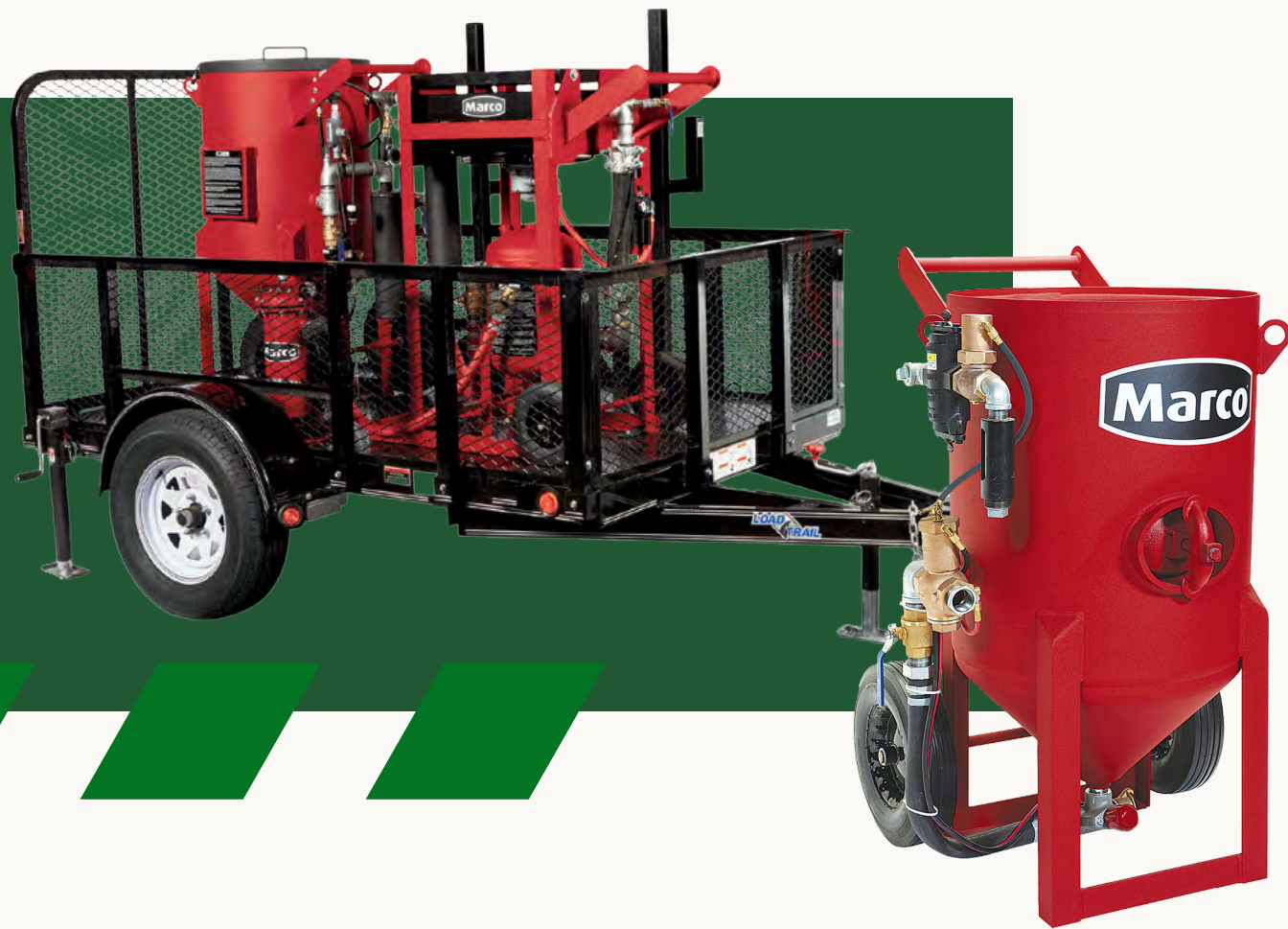

Let's talk about why renting could be your new go-to strategy.

SAY GOODBYE TO MAINTENANCE HEADACHES

When you rent, you can wave goodbye to maintenance bills and late-night repair sessions. The rental company handles the upkeep, parts, and those midnight emergency fixes that give equipment owners gray hair.

FAITHFUL ISN'T SO FAITHFUL

When your own equipment decides to take an unscheduled break, rental gear keeps your projects moving. No more explaining to clients why you're behind schedule—you've got a backup plan ready to roll.

TRY BEFORE YOU BUY

Rental fleets are like the cool kids of the equipment world—always sporting the latest gear. You get to test-drive the newest technology without committing to a purchase, helping you make smarter buying decisions down the road.

LOCATION, LOCATION, LOCATION

Got a job on the other side of the country? Rent locally and save yourself the hassle and expense of long-distance equipment transport. Plus, you get the bonus of local support and service when you need it.

TAP INTO EXPERT MINDS

Rental staff are like your personal equipment gurus. They've seen it all, done it all, and can help you pick the perfect tool for your job. Their expertise comes free with your rental—now that's a deal!

DODGE THE HIDDEN COSTS

Insurance, taxes, maintenance supplies—renting often bundles these pesky expenses into one predictable payment. No surprises means better budgeting for your business.

STORAGE? WHAT STORAGE?

No more playing Tetris with your equipment when the job's done. Return it, reclaim your space, and let someone else worry about where to park that massive piece of machinery.



WHEN BUYING PUTS YOU IN THE DRIVER'S SEAT



Alright, now let's talk about why owning your gear might be the smart play.

KNOW YOUR TOOL INSIDE OUT

When you own it, you know every quirk and feature like the back of your hand. This intimate knowledge means faster work, better results, and fewer rookie mistakes on the job site.

REPEAT PERFORMER

If you're doing the same type of work day in and day out, ownership starts to make dollars and sense. The more you use it, the better your return on investment—simple as that.

SHOW ME THE MONEY

Sometimes, owning just makes financial sense, especially when you can build equipment costs into your job quotes. Over time, that investment pays for itself and then some, becoming a reliable profit center for your business.

THE POWER OF BLENDING: BEST OF BOTH WORLDS



Here's where things get interesting—why not have your cake and eat it too?

CORE STRENGTH, FLEX APPEAL

Own your everyday workhorses but rent the specialized stuff. This way, you've got your bases covered for regular jobs while maintaining the flexibility to take on unique projects that need specific equipment.

MODERNIZATION ON A BUDGET

Keep your reliable standards in-house but rent the latest tech when you need it. Stay competitive without constantly chasing the newest models with your checkbook.

CASH FLOW MAGIC

Buying essential equipment spreads costs over time, while renting helps you manage sudden equipment needs without draining your bank account. It's about keeping your cash flow healthy and your options open.

GROW LIKE A PRO

As your business expands, use both buying and renting to smartly scale up. Take on bigger projects without overcommitting to equipment you might not need next month.



WRAPPING IT UP

So, there you have it—the inside scoop on renting, buying, and blending in the wild world of industrial blasting. Remember, there’s no one-size-fits-all answer here. It’s all about what makes sense for your business, your projects, and your bottom line.

Keep in mind that what works today might need tweaking tomorrow. The beauty of a blended approach is that you can adjust as your business evolves. Stay flexible, keep your eyes on the market, and you’ll find the sweet spot that works for you.

For more information on renting equipment from Allredi, visit: <https://www.allredi.com/rental-service>

Allredi is your right-now supplier, so you can keep your projects moving. From our foundation of strong relationships, we have built a nationwide network that puts vast inventory and ready service close to our customers. We provide advanced expertise, and we deliver the goods fast – so you can easily access the products and services you need to be more agile every minute, every day.

 Call (US) 1.800.252.7848 | (CAN) 1.800.661.3842 or visit [allredi.com](https://www.allredi.com) to learn more.

